

This drawing is confidential and must not be reproduced or used without the consent of EXM

Ce dessin est confidentiel et ne doit pas être reproduit ou utilisé sans le consentement de EXM



TOP



BACK

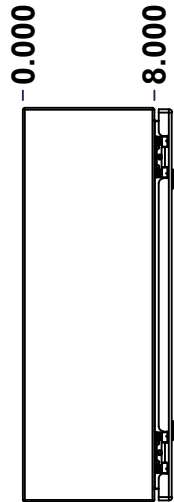

LEFT

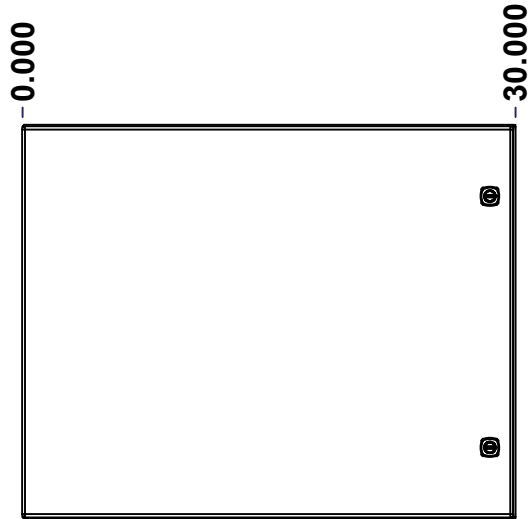

FRONT

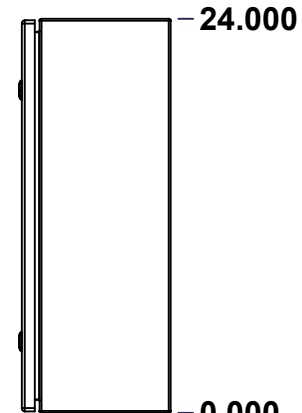

RIGHT

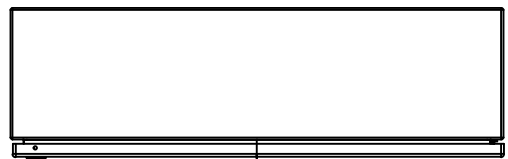

BOTTOM

| No. | Revisions | Date | By/Par |
|-----|-----------|------|--------|
|     |           |      |        |
|     |           |      |        |
|     |           |      |        |
|     |           |      |        |
|     |           |      |        |

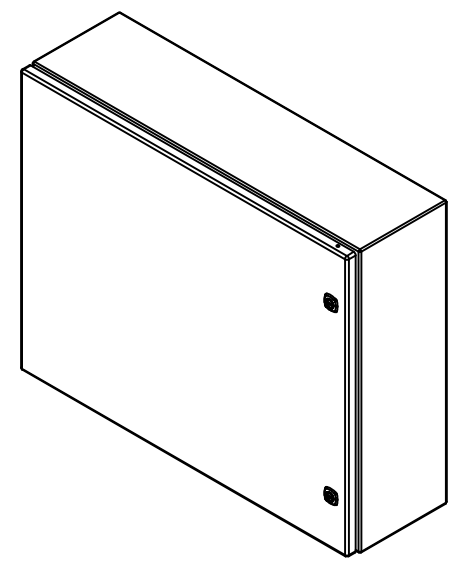

Isometric View



Tél: (450) 979-4373  
 Fax: (450) 979-4626  
[www.exmweb.com](http://www.exmweb.com)

Flatness  
 Aplatissement  
 Max 3.0mm  
 Projection

|   |                       |
|---|-----------------------|
| Customer Client                               | Date                  |
| Drawn By / Dessiné Par: BoxCad: BoxCad        | Date: 28-Aug-14       |
| Material / Matière: Aluminum 5052-H32 (2.3mm) |                       |
| Color / Couleur: Asa-61 Grey                  | Finish / Fini: Smooth |
| Description: 5412EAL 24" x 30" x 8" Assembly  | Detail Rev.           |
| Part Number / Numéro Pièce: 5412EAL243008     | Rev. 0                |

SEE BILL OF MATERIAL ON LAST PAGE

1  
9

This drawing is confidential and must not be reproduced or used without the consent of EXM

Ce dessin est confidentiel et ne doit pas être reproduit ou utilisé sans le consentement de EXM

| NOTE |  |
|------|--|
| ITEM | DESCRIPTION                                |
| 1    | NEMA 4X Enclosure                          |
| 2    | C/W Standard ground studs on box and cover |
| 3    | C/W Standard door stiffener                |
| 4    | C/W Standard inner panel (Included)        |
| 5    | C/W Standard inner panel mounting studs    |
| 6    | C/W 880 PP included (Not installed)        |

| No. | Revisions | Date | By/Par |
|-----|-----------|------|--------|
|     |           |      |        |
|     |           |      |        |
|     |           |      |        |
|     |           |      |        |
|     |           |      |        |
|     |           |      |        |

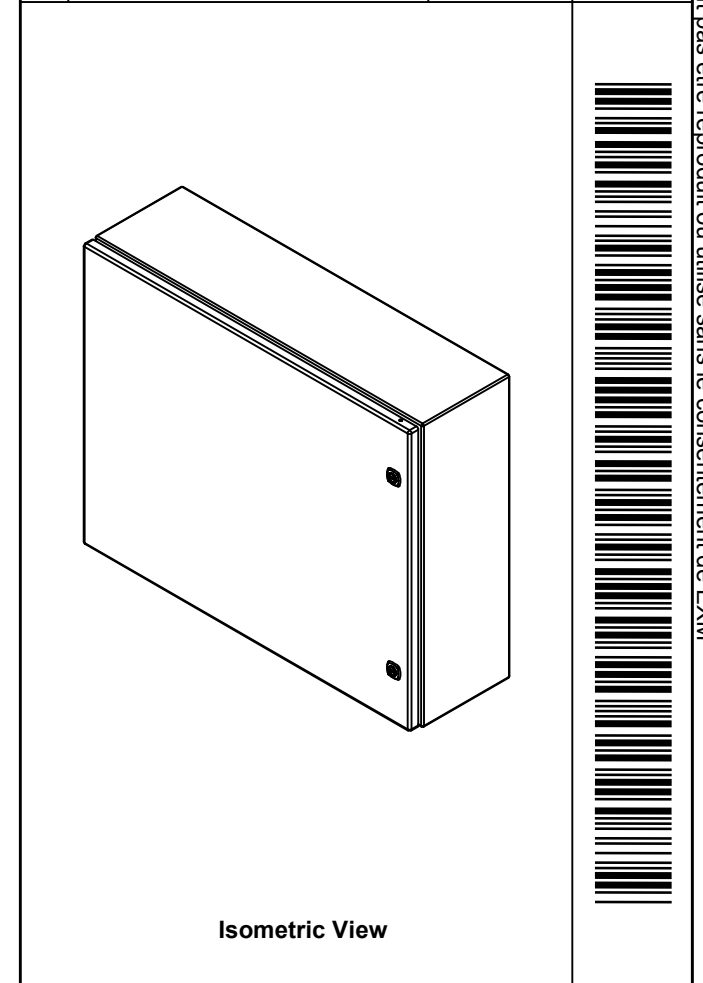

**EXM**  
www.exm.com

Tél: (450) 979-4373  
Fax: (450) 979-4626  
[www.exmweb.com](http://www.exmweb.com)

Flatness  
Aplatissement  
Max 3.0mm

Projection

|                         |                |
|-------------------------|----------------|
| Customer Client         | Date           |
| Drawn By<br>Dessiné Par | Date 28-Aug-14 |

|                     |                           |
|---------------------|---------------------------|
| Material<br>Matière | Aluminum 5052-H32 (2.3mm) |
|---------------------|---------------------------|

|                  |             |                |        |
|------------------|-------------|----------------|--------|
| Color<br>Couleur | Asa-61 Grey | Finish<br>Fini | Smooth |
|------------------|-------------|----------------|--------|

|                                 |             |
|---------------------------------|-------------|
| Description                     | Detail Rev. |
| 5412EAL 24" x 30" x 8" Assembly |             |

|                             |          |   |
|-----------------------------|----------|---|
| Part Number<br>Numéro Pièce | Rev.     | 2 |
| <b>5412EAL243008</b>        | <b>0</b> | 9 |

| Qty | Part Number    | Rev | Description                                |
|-----|----------------|-----|--|
| 2   | STK-Q-07310    | 2   | Flange Lock Nut M8                         |
| 1   | 881 SP3024G    | 0   | 881 SP - Inner Panel                       |
| 2   | STK-Q-07615    | 0   | Inner Panel Support Bracket                |
| 1   | STK-K-01320    | 0   | 5412 ES Inner Panel Accessory Kit          |
| 1   | 880 PP         | 6   | Self Adhesive Print Pocket                 |
| 1   | STK-K-01800    | 5   | 5412 ES Accessory Kit                      |
| 1   | 5412EAL243008C | 0   | 5412EAL 24" x 30" Cover                    |
| 1   | 5412EAL243008B | 0   | 5412EAL 24" x 30" x 8" Body                |
| 2   | STK-Q-04050-08 | 0   | M6 x 8mm Hexagon Socket Head Machine Screw |

Parts List

| PACKING               |     |  |
|-----------------------|-----|--|
| ITEM                  | QTY | DESCRIPTION                                |
| Cardboard sleeve      | 2   | Top and Bottom                             |
| Cardboard strip       | 2   | Between back of enclosure and inner panel  |
| Plastic bag           | 1   | To protect cover surface and inside gasket |
| Plastic strap - Black | 2   | To Squeeze the 2 cardboard sleeve together |
| Packaging label       | 1   | White label with product number            |

This drawing is confidential and must not be reproduced or used without the consent of EXM

Ce dessin est confidentiel et ne doit pas être reproduit ou utilisé sans le consentement de EXM

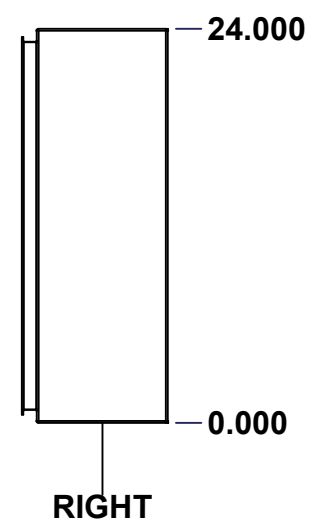
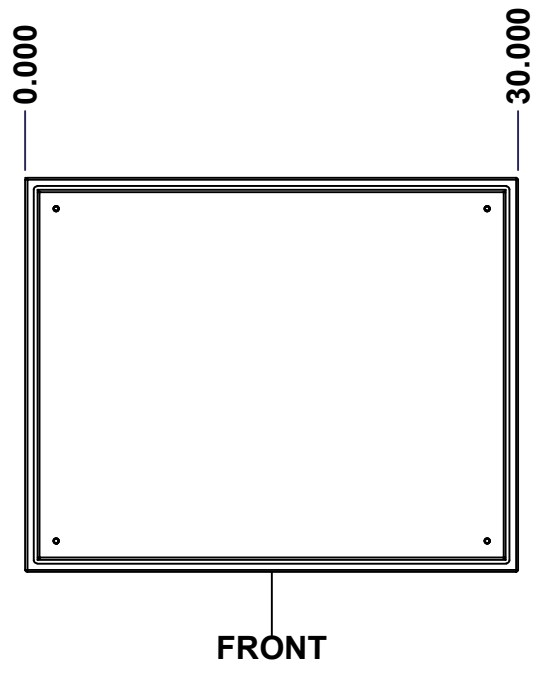
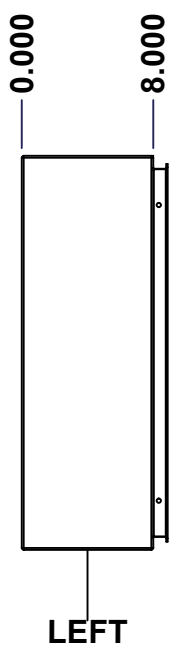
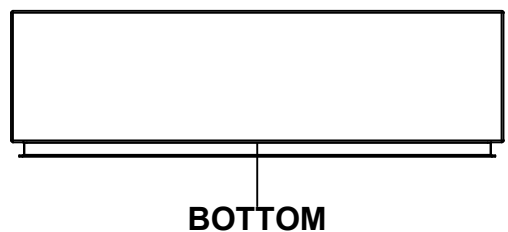
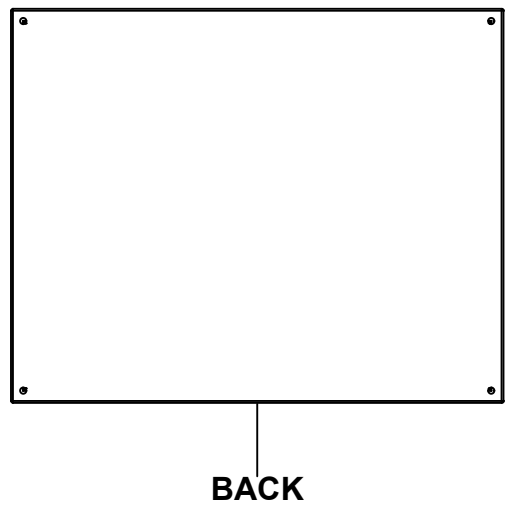
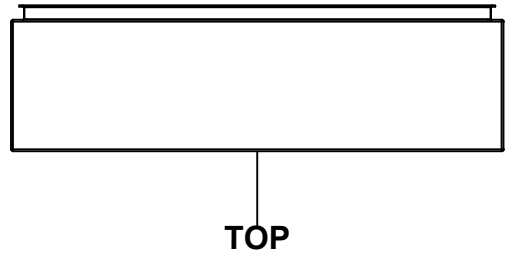

| No. | Revisions | Date | By/Par |
|-----|-----------|------|--------|
|     |           |      |        |
|     |           |      |        |
|     |           |      |        |
|     |           |      |        |
|     |           |      |        |

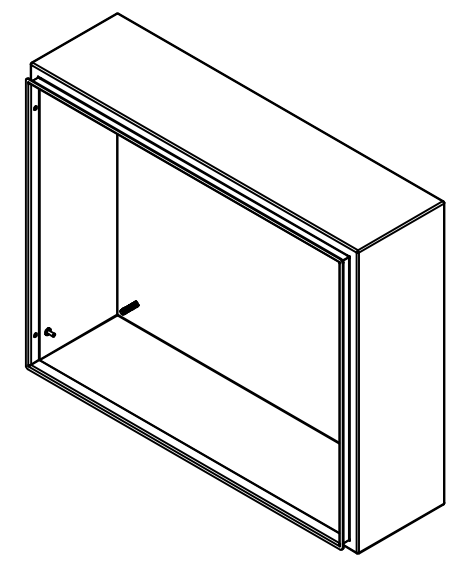

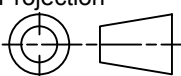
|  |                           |   |
|--|---------------------------|---|
|  Tél: (450) 979-4373<br>Fax: (450) 979-4626<br><a href="http://www.exmweb.com">www.exmweb.com</a> |                           | Flatness<br>Aplatissement<br>Max 3.0mm<br>Projection<br> |
| Customer Client  | Date                      |   |
| Drawn By<br>Dessiné Par  | BoxCad: BoxCad            | Date 28-Aug-14  |
| Material<br>Matière  | Aluminum 5052-H32 (2.3mm) |   |
| Color<br>Couleur   | Asa-61 Grey               | Finish<br>Fini Smooth   |
| Description  | Detail Rev.               |   |
| 5412EAL 24" x 30" x 8" Body  |                           |   |
| Part Number<br>Numéro Pièce  | Rev.                      | 3   |
| <b>5412EAL243008B</b>  | <b>0</b>                  | 9   |

**SEE BILL OF MATERIAL ON LAST PAGE**

This drawing is confidential and must not be reproduced or used without the consent of EXM

Ce dessin est confidentiel et ne doit pas être reproduit ou utilisé sans le consentement de EXM

| <b>STANDARD FEATURES ARE NOT LISTED IN THIS HOLE TABLE</b> |       |       |                             |
|--|-------|-------|-----------------------------|
| <b>HOLE TABLE - LEFT VIEW (CUSTOM FEATURE ONLY)</b>        |       |       |                             |
| CUT-OUT  | XDIM  | YDIM  | DESCRIPTION                 |
| 1  | 6.500 | 2.000 | GND STUD M6 x 16mm (Inside) |

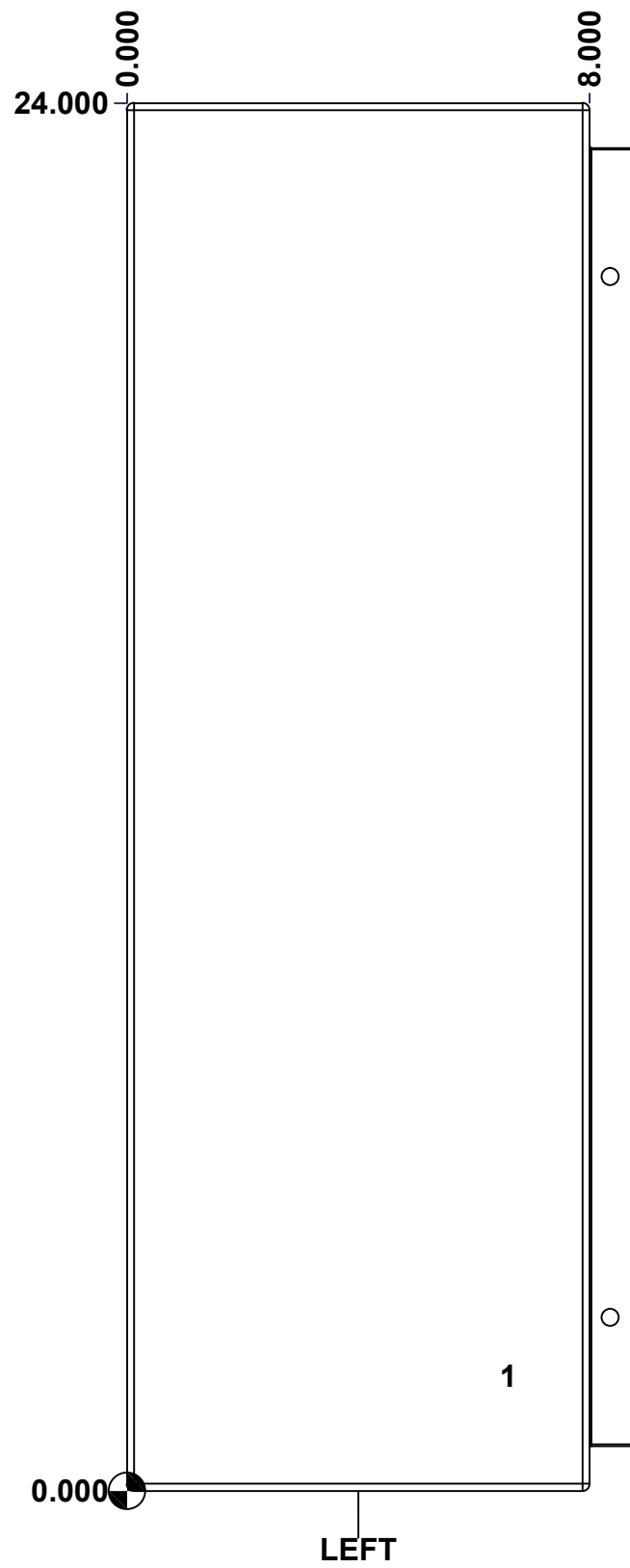

|  |                             |          |     |
|--|-----------------------------|----------|-----|
|  | Description                 | Status   |     |
|  | 5412EAL 24" x 30" x 8" Body | (NULL)   |     |
|  | Part Number<br>Numéro Pièce | Rev.     |     |
|  | <b>5412EAL243008B</b>       | <b>0</b> | 4/9 |

This drawing is confidential and must not be reproduced or used without the consent of EXM

Ce dessin est confidentiel et ne doit pas être reproduit ou utilisé sans le consentement de EXM

**STANDARD FEATURES ARE NOT LISTED IN THIS HOLE TABLE**

**HOLE TABLE - BACK VIEW (CUSTOM FEATURE ONLY)**

| CUT-OUT | XDIM   | YDIM   | DESCRIPTION                |
|---------|--------|--------|----------------------------|
| 1       | 1.875  | 1.875  | IP STUD M8 x 35mm (Inside) |
| 2       | 1.875  | 22.125 | IP STUD M8 x 35mm (Inside) |
| 3       | 28.125 | 22.125 | IP STUD M8 x 35mm (Inside) |
| 4       | 28.125 | 1.875  | IP STUD M8 x 35mm (Inside) |
| -----   |        |        |                            |
| 5       | 29.250 | 0.750  | RND Ø0.390                 |
| 6       | 29.250 | 23.250 | RND Ø0.390                 |
| 7       | 0.750  | 23.250 | RND Ø0.390                 |
| 8       | 0.750  | 0.750  | RND Ø0.390                 |

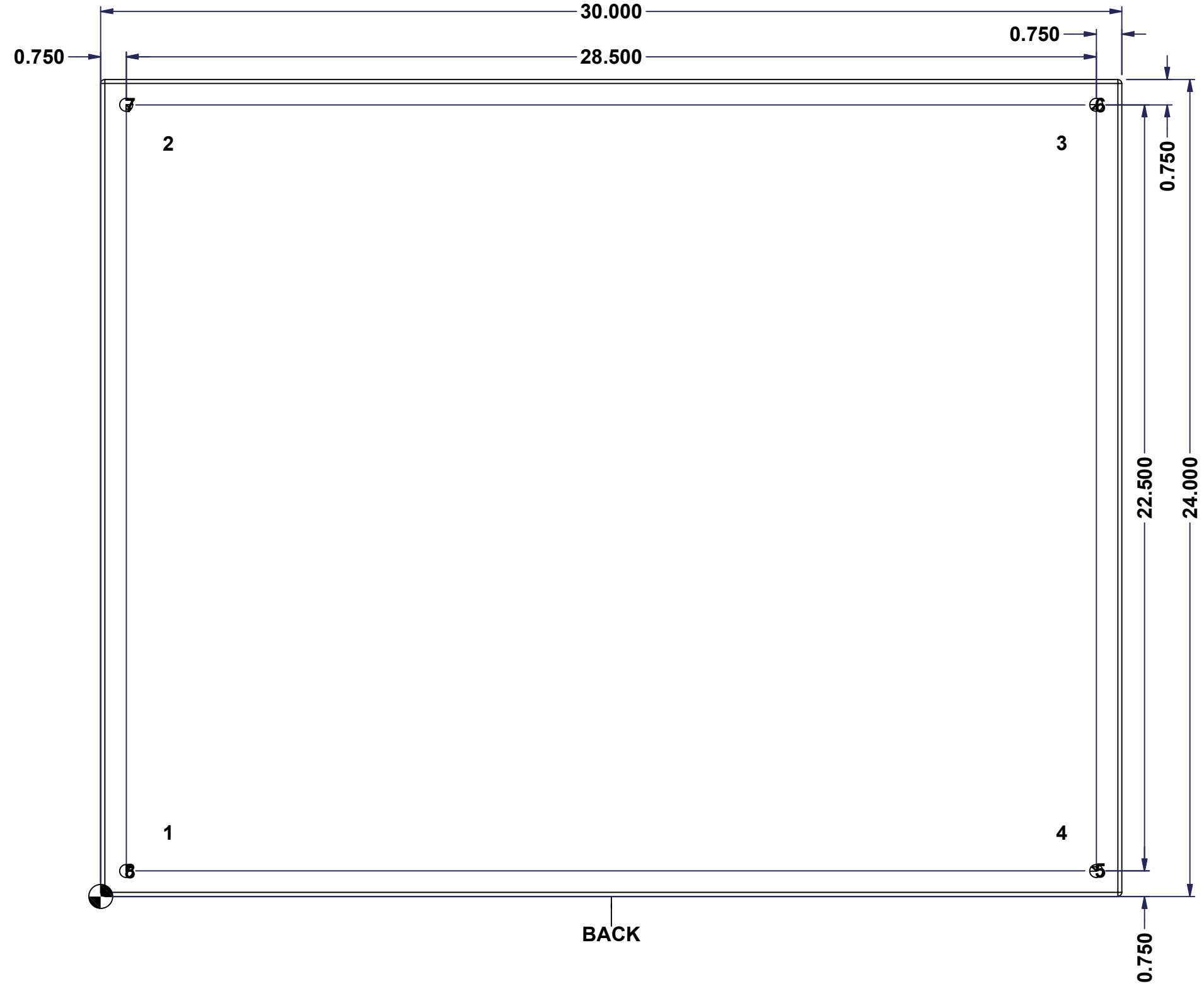

|  |                             |                       |   |
|--|-----------------------------|-----------------------|---|
|  | Description                 | Status                |   |
|  | 5412EAL 24" x 30" x 8" Body | (NULL)                |   |
|  | Part Number                 | Rev.                  | 5 |
|  | Numéro Pièce                | <b>0</b>              | 9 |
|  |                             | <b>5412EAL243008B</b> |   |

This drawing is confidential and must not be reproduced or used without the consent of EXM

Ce dessin est confidentiel et ne doit pas être reproduit ou utilisé sans le consentement de EXM

| No. | Revisions | Date | By/Par |
|-----|-----------|------|--------|
|     |           |      |        |
|     |           |      |        |
|     |           |      |        |
|     |           |      |        |
|     |           |      |        |

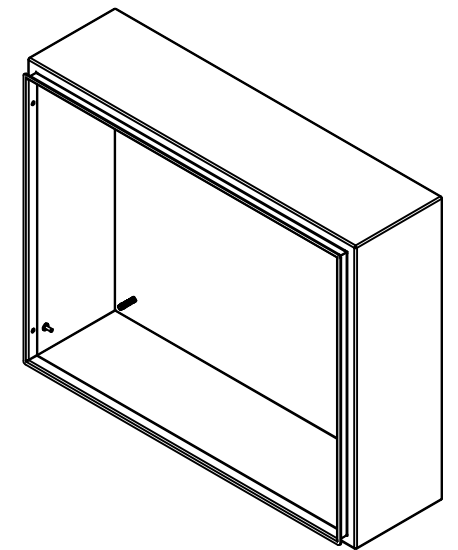

Isometric View



Tél: (450) 979-4373  
 Fax: (450) 979-4626  
[www.exmweb.com](http://www.exmweb.com)

Flatness  
Aplatissement  
Max 3.0mm  
Projection

|   |                       |
|---|-----------------------|
| Customer Client                               | Date                  |
| Drawn By<br>Dessiné Par BoxCad: BoxCad        | Date 28-Aug-14        |
| Material<br>Matière Aluminum 5052-H32 (2.3mm) |                       |
| Color<br>Couleur Asa-61 Grey                  | Finish<br>Fini Smooth |

| Qty        | Part Number      | Rev | Description                         |
|------------|------------------|-----|-------------------------------------|
| 1          | STK-Q-16090      | 0   | Ground Stud M6 x 16mm Aluminum      |
| 1          | STK-P-02400S     | 0   | Powder Paint (Asa-61 Grey / Smooth) |
| 4          | STK-Q-16010      | 0   | Stud M8 x 35mm Aluminum             |
| 1          | 5412EAL243008B-P | 0   | 5412EAL 24" x 30" x 8" Body Part    |
| Parts List |                  |     |                                     |

|  |                      |
|--|----------------------|
| Description<br>5412EAL 24" x 30" x 8" Body           | Detail Rev.          |
| Part Number<br>Numéro Pièce<br><b>5412EAL243008B</b> | Rev. 6<br><b>0</b> 9 |

This drawing is confidential and must not be reproduced or used without the consent of EXM

Ce dessin est confidentiel et ne doit pas être reproduit ou utilisé sans le consentement de EXM

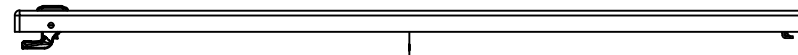

TOP

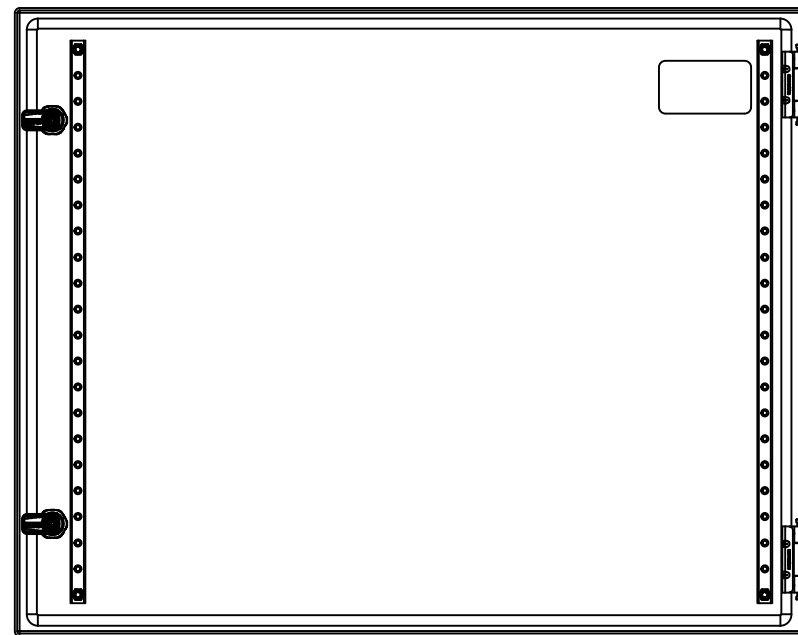

BACK

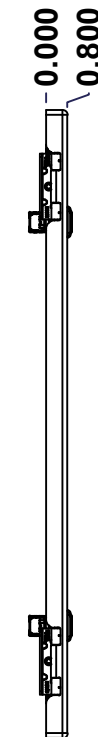

LEFT

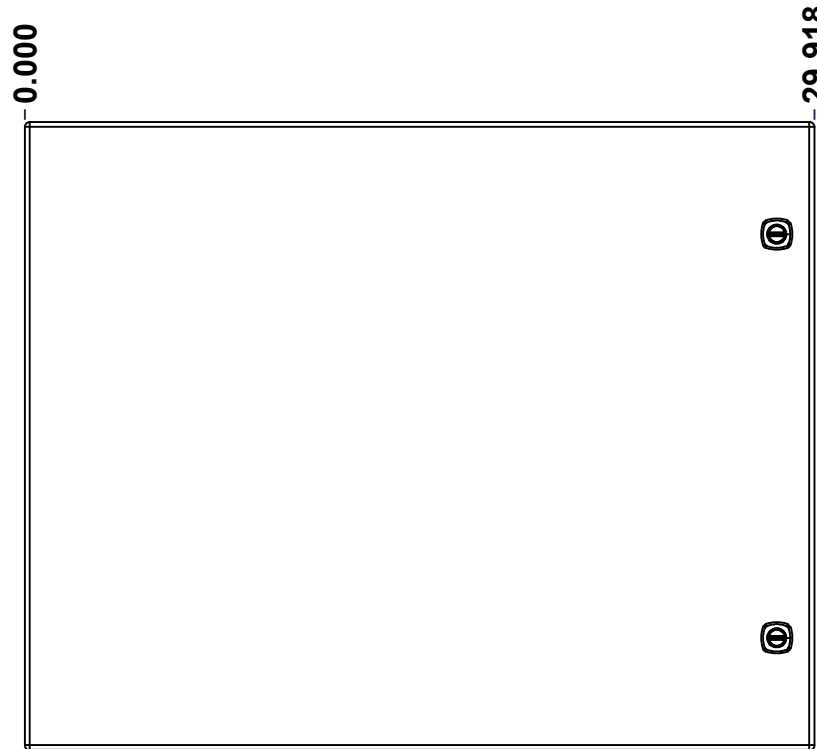

FRONT

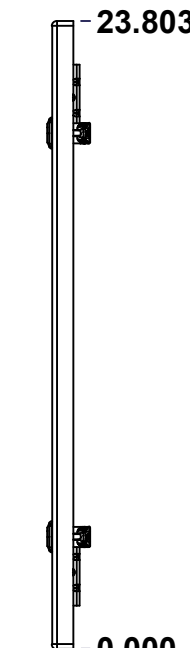

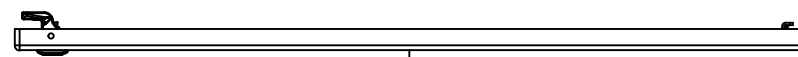

RIGHT

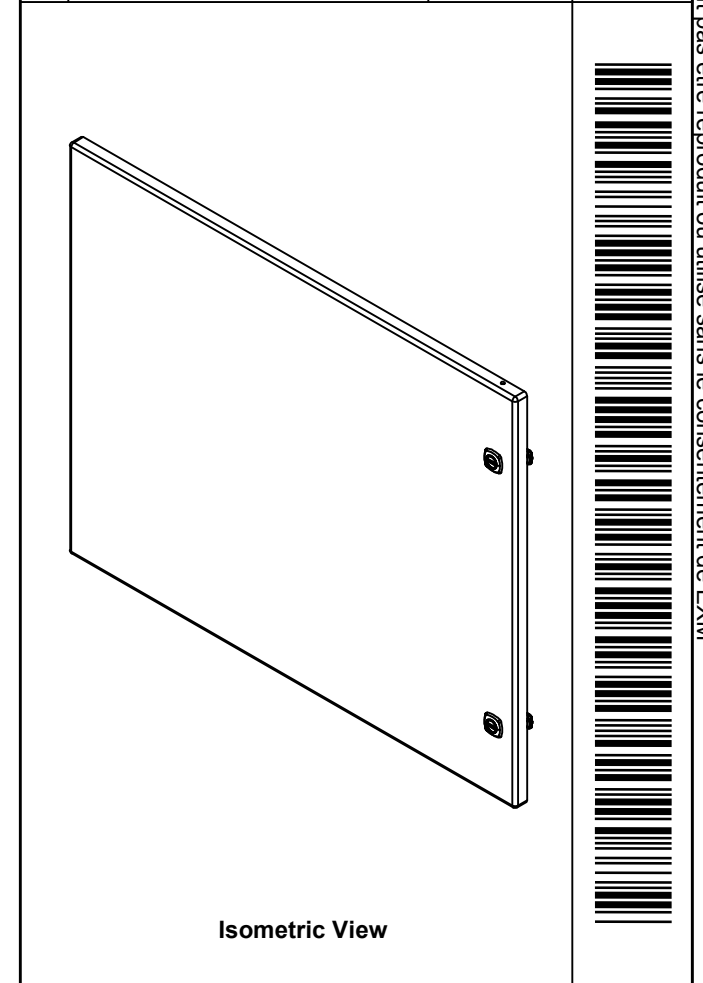

BOTTOM

| No. | Revisions | Date | By/Par |
|-----|-----------|------|--------|
|     |           |      |        |
|     |           |      |        |
|     |           |      |        |
|     |           |      |        |



|  |  |                           |             |
|--|--|---------------------------|-------------|
|  Tél: (450) 979-4373<br>Fax: (450) 979-4626<br><a href="http://www.exmweb.com">www.exmweb.com</a> |  | Flatness<br>Aplatissement |             |
|  |  | Max 3.0mm                 |             |
| Customer<br>Client   |  | Date                      |             |
| Drawn By<br>Dessiné Par BoxCad: BoxCad   |  | Date 28-Aug-14            |             |
| Material<br>Matière Aluminum 5052-H32 (2.3mm)  |  |                           |             |
| Color<br>Couleur Asa-61 Grey   |  | Finish<br>Fini Smooth     |             |
| Description<br>5412EAL 24" x 30" Cover   |  |                           | Detail Rev. |
| Part Number<br>Numéro Pièce <b>5412EAL243008C</b>  |  | Rev. <b>0</b>             | 7<br>9      |

SEE BILL OF MATERIAL ON LAST PAGE

This drawing is confidential and must not be reproduced or used without the consent of EXM

Ce dessin est confidentiel et ne doit pas être reproduit ou utilisé sans le consentement de EXM

| STANDARD FEATURES ARE NOT LISTED IN THIS HOLE TABLE |        |        |                         |
|---|--------|--------|-------------------------|
| HOLE TABLE - FRONT VIEW (CUSTOM FEATURE ONLY)       |        |        |                         |
| CUT-OUT   | XDIM   | YDIM   | DESCRIPTION             |
| 1   | 1.486  | 1.567  | STUD M6 x 18mm (Inside) |
| 2   | 1.486  | 22.236 | STUD M6 x 18mm (Inside) |
| 3   | 27.517 | 22.236 | STUD M6 x 18mm (Inside) |
| 4   | 27.517 | 1.567  | STUD M6 x 18mm (Inside) |
| -----   |        |        |                         |
| 5   | 28.494 | 19.553 | 880 SCQ4-SL             |
| 6   | 28.494 | 4.250  | 880 SCQ4-SL             |
| 7   | 3.750  | 20.803 | LABEL_EXM (Inside)      |



FRONT

|  |                             |          |        |
|--|-----------------------------|----------|--------|
|  | Description                 | Status   |        |
|  | 5412EAL 24" x 30" Cover     | (NULL)   |        |
|  | Part Number<br>Numéro Pièce | Rev.     |        |
|  | <b>5412EAL243008C</b>       | <b>0</b> | 8<br>9 |



This drawing is confidential and must not be reproduced or used without the consent of EXM

Ce dessin est confidentiel et ne doit pas être reproduit ou utilisé sans le consentement de EXM

| No. | Revisions | Date | By/Par |
|-----|-----------|------|--------|
|     |           |      |        |
|     |           |      |        |
|     |           |      |        |
|     |           |      |        |
|     |           |      |        |

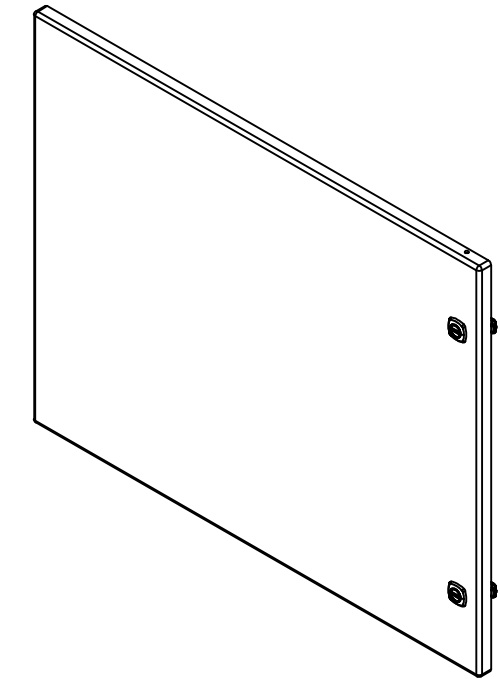

Isometric View



Tél: (450) 979-4373  
 Fax: (450) 979-4626  
[www.exmweb.com](http://www.exmweb.com)

Flatness  
Aplatissement  
Max 3.0mm  
Projection

|  |                       |
|--|-----------------------|
| Customer Client                                      | Date                  |
| Drawn By<br>Dessiné Par BoxCad: BoxCad               | Date 28-Aug-14        |
| Material<br>Matière Aluminum 5052-H32 (2.3mm)        |                       |
| Color<br>Couleur Asa-61 Grey                         | Finish<br>Fini Smooth |
| Description<br>5412EAL 24" x 30" Cover               | Detail Rev.           |
| Part Number<br>Numéro Pièce<br><b>5412EAL243008C</b> | Rev. 9<br><b>0</b>    |

| Qty        | Part Name        | Rev | Description                            |
|------------|------------------|-----|--|
| 1          | STK-S-00100      | 0   | 3.5" x 2" Silver Milar Flexcon Sticker |
| 1          | STK-P-02400S     | 0   | Powder Paint (Asa-61 Grey / Smooth)    |
| 2          | STK-Q-46020-24   | 5   | 5412 ES Vertical Door Stiffener 24"    |
| 4          | STK-Q-16060      | 0   | Stud M6 x 18mm Aluminum                |
| 1          | 5412EAL243008G   | 0   | 5412EAL 24" x 30" Cover Gasket Part    |
| 1          | 5412EAL243008C-P | 0   | 5412EAL 24" x 30" Cover Part           |
| 2          | STK-A-33016      | 0   | 5412 ESS Bended Hinge (Body Part)      |
| 2          | 880 SCQ4-SL      | 6   | 5412 ES 1/4 Turn Lock                  |
| 4          | STK-Q-07220      | 1   | M6 Nylon Insert Lock Nut               |
| Parts List |                  |     |  |

This drawing is confidential and must not be reproduced or used without the consent of EXM

Ce dessin est confidentiel et ne doit pas être reproduit ou utilisé sans le consentement de EXM

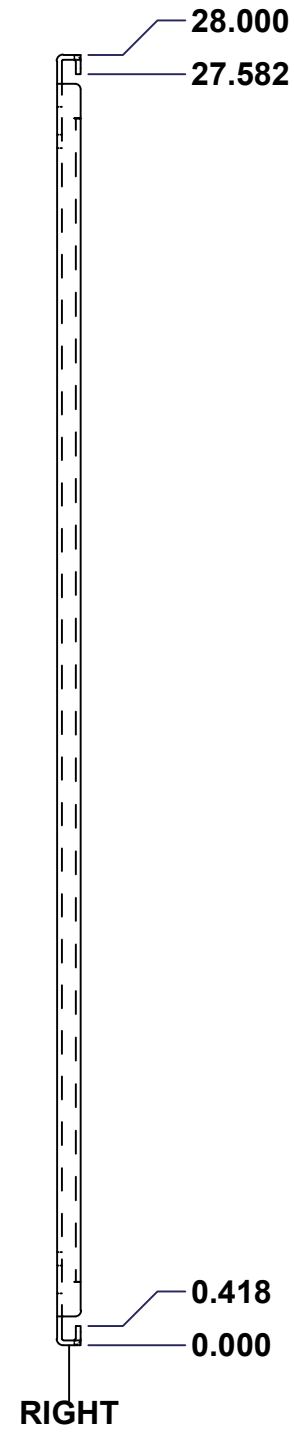
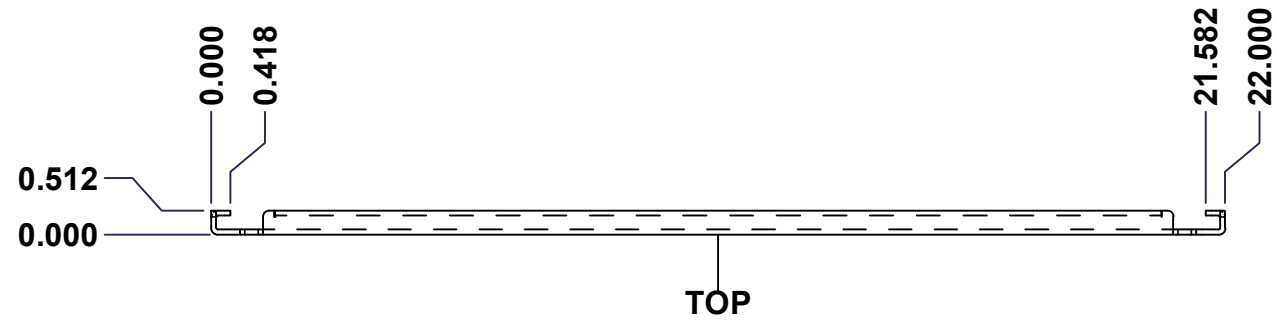

| No. | Revisions | Date | By/Par |
|-----|-----------|------|--------|
|     |           |      |        |
|     |           |      |        |
|     |           |      |        |
|     |           |      |        |
|     |           |      |        |

Isometric View

|  |                           |
|--|---------------------------|
| Tél: (450) 979-4373<br>Fax: (450) 979-4626<br>www.exmweb.com | Flatness<br>Aplatissement |
|  | Max 3.0mm                 |
| Projection   |                           |
| Customer Client  | Date                      |
| Drawn By<br>Dessiné Par BoxCad                               | Date 23-Jan-07            |
| Material<br>Matière  | See Part List             |
| Color<br>Couleur   | See Part List             |
| Finish<br>Fini   | See Part List             |
| Description  | Detail Rev.               |
| 881 SP - Inner Panel   |                           |
| Part Number<br>Numéro Pièce                                  | Rev. 1                    |
| <b>881 SP3024G</b>   | <b>0</b> 2                |

| Qty | Part Number   | Rev | Description               | Material         | Color     | Finish     |
|-----|---------------|-----|---------------------------|------------------|-----------|------------|
| 1   | 881 SP3024G-P | 0   | 881 SP - Inner Panel Part | 12 Ga Galvanized | Unpainted | Galvanized |

Parts List

This drawing is confidential and must not be reproduced or used without the consent of EXM

Ce dessin est confidentiel et ne doit pas être reproduit ou utilisé sans le consentement de EXM

| Table 1 |        |        | FRONT VIEW               |
|---------|--------|--------|--------------------------|
| CUT-OUT | XDIM   | YDIM   | DESCRIPTION              |
| 1       | 0.875  | 1.875  | GROUND HOLE (RND Ø0.290) |
| 2       | 21.125 | 1.875  | GROUND HOLE (RND Ø0.290) |
| 3       | 0.875  | 26.125 | GROUND HOLE (RND Ø0.290) |
| 4       | 21.125 | 26.125 | GROUND HOLE (RND Ø0.290) |

All knockouts are actual size / Les disques défonçables sont grandeur réel

| No. | Revisions | Date | By/Par |
|-----|-----------|------|--------|
|     |           |      |        |
|     |           |      |        |
|     |           |      |        |
|     |           |      |        |
|     |           |      |        |

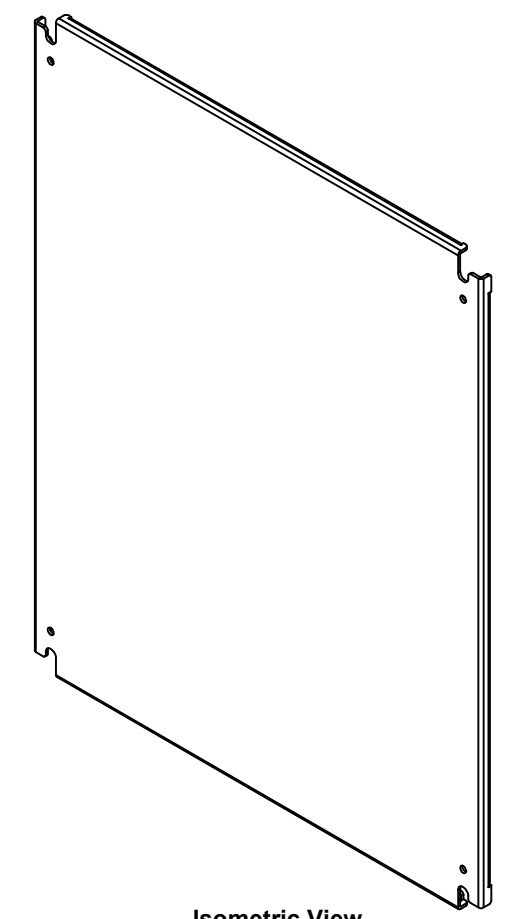
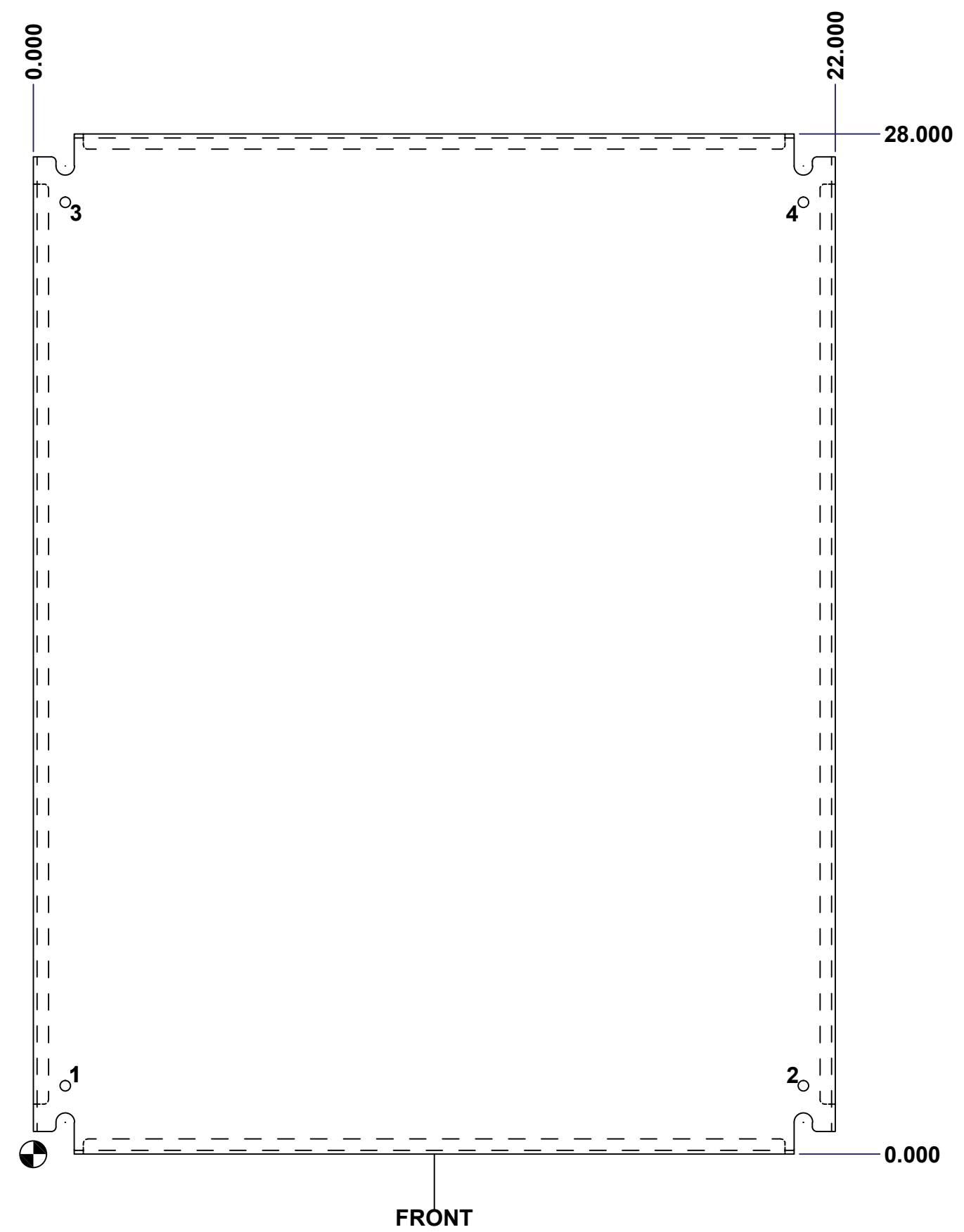

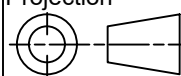
|  |               |   |
|--|---------------|---|
|  Tél: (450) 979-4373<br>Fax: (450) 979-4626<br>www.exmweb.com |               | Flatness<br>Aplatissement<br>Max 3.0mm<br>Projection<br> |
| Customer Client  | Date          |   |
| Drawn By<br>Dessiné Par  | BoxCad        | Date 23-Jan-07  |
| Material<br>Matière  | See Part List |   |
| Color<br>Couleur   | See Part List | Finish<br>Fini See Part List  |
| Description<br>881 SP - Inner Panel  |               | Detail Rev.   |
| Part Number<br>Numéro Pièce  | 881 SP3024G   | Rev. 2<br>0   |