

This drawing is confidential and must not be reproduced or used without the consent of EXM

Ce dessin est confidentiel et ne doit pas être reproduit ou utilisé sans le consentement de EXM

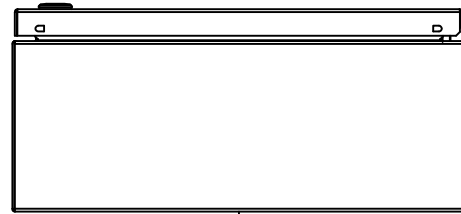

TOP

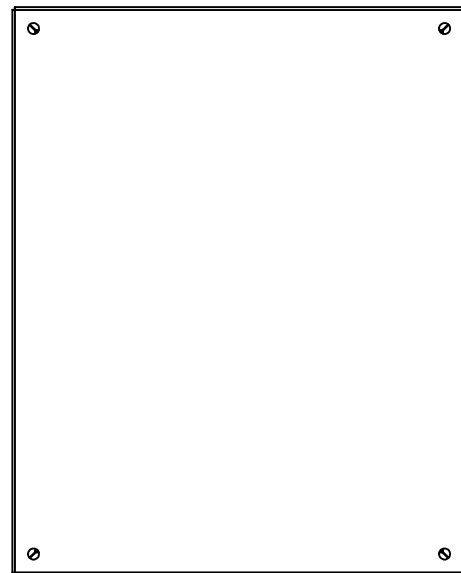

BACK

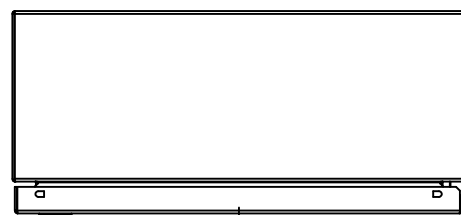

BOTTOM

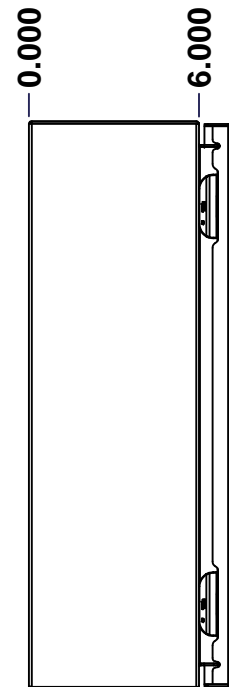

LEFT

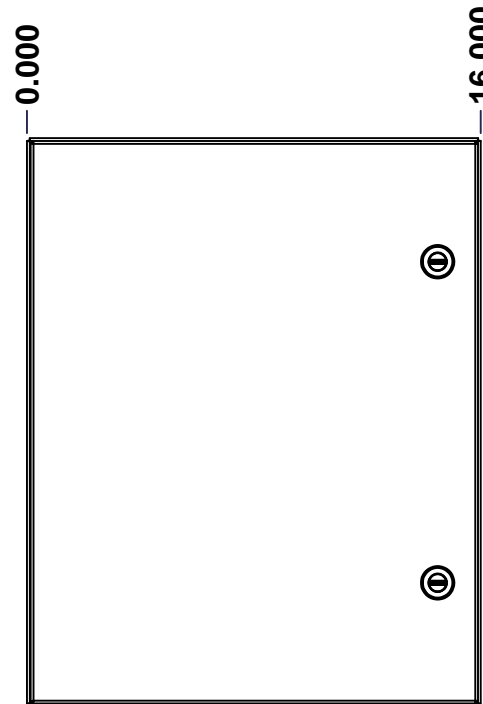

FRONT

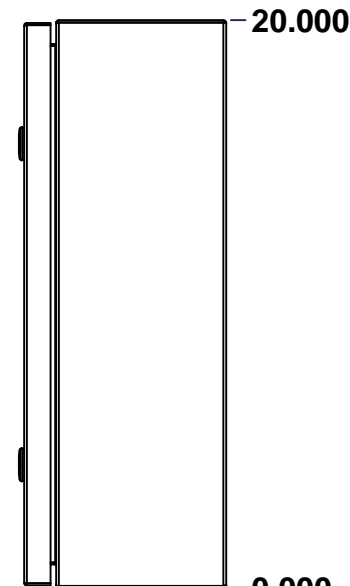

RIGHT

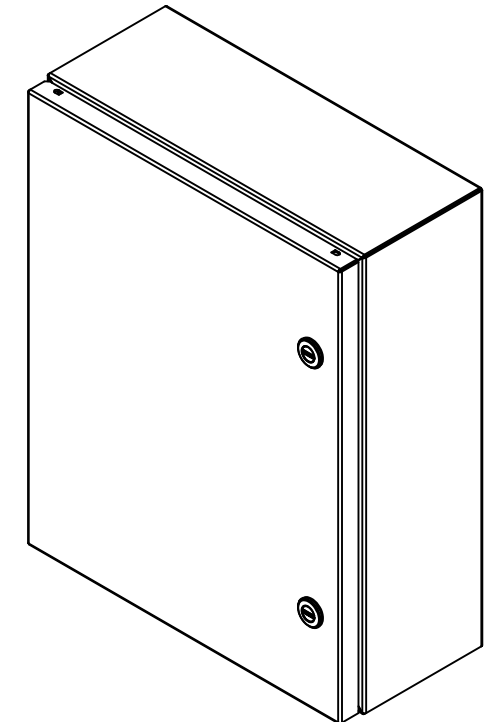

Isometric View

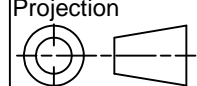

| No. | Revisions | Date | By/Par |
|-----|-----------|------|--------|
| | | | |
| | | | |
| | | | |
| | | | |
| | | | |

| | | |
|--|---------------------------|---|
|  Tél: (450) 979-4373 Fax: (450) 979-4626 www.exmweb.com | | Flatness Aplatissement Max 3.0mm Projection  |
| Customer Client | Date | |
| Drawn By Dessiné Par | BoxCad: Annie | Date 10/03/2015 |
| Material Matière | Aluminum 5052-H32 (1.7mm) | |
| Color Couleur | Asa-61 Grey | Finish Finis Smooth |
| Description | Detail Rev. | |
| 5412EALBU 20" x 16" x 6" Assembly | | |
| Part Number Numéro Pièce | Rev. | 1 |
| 5412EALBU201606 | 0 | 2 |

SEE BILL OF MATERIAL ON LAST PAGE

This drawing is confidential and must not be reproduced or used without the consent of EXM

Ce dessin est confidentiel et ne doit pas être reproduit ou utilisé sans le consentement de EXM

| NOTE | |
|------|--|
| ITEM | DESCRIPTION |
| 1 | NEMA 4X Enclosure |
| 2 | C/W Standard ground studs on box and cover |
| 3 | C/W Standard door stiffener |
| 4 | C/W Standard inner panel (Sold seperately) |
| 5 | C/W Standard inner panel mounting studs |

| No. | Revisions | Date | By/Par |
|-----|-----------|------|--------|
| | | | |
| | | | |
| | | | |
| | | | |
| | | | |
| | | | |

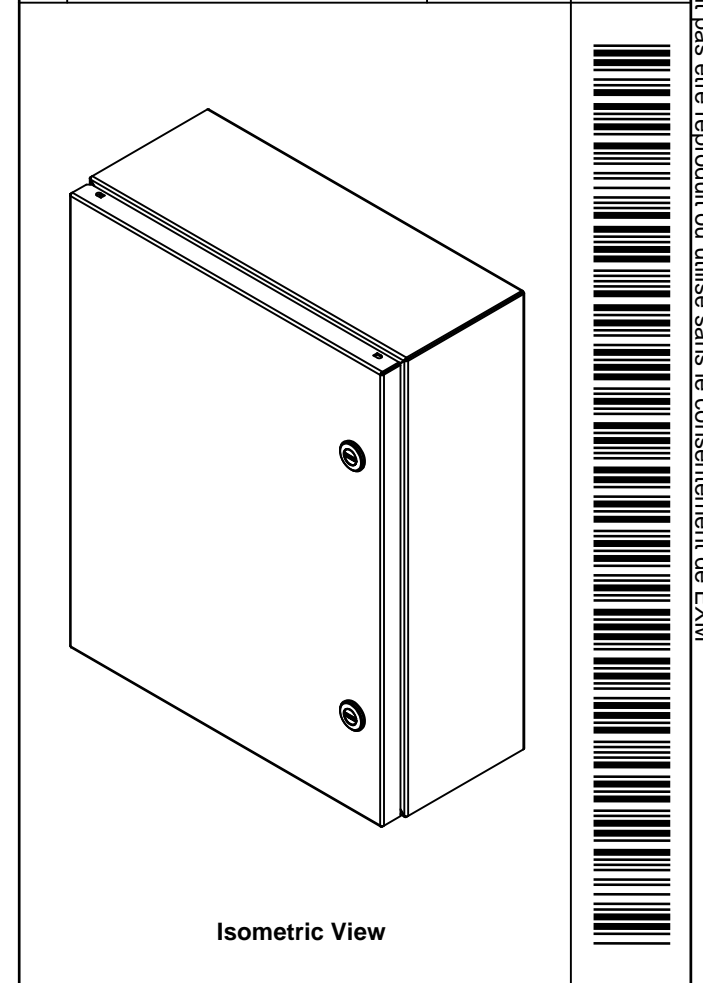

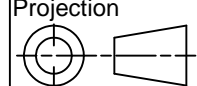
| | | |
|--|---------------------------|---|
|  Tél: (450) 979-4373 Fax: (450) 979-4626 www.exmweb.com | | Flatness Aplatissement Max 3.0mm Projection  |
| Customer Client | Date | |
| Drawn By Dessiné Par | BoxCad: Annie | Date 10/03/2015 |
| Material Matière | Aluminum 5052-H32 (1.7mm) | |
| Color Couleur | Asa-61 Grey | Finish Fini Smooth |
| Description | Detail Rev. | |
| 5412EALBU 20" x 16" x 6" Assembly | | |
| Part Number Numéro Pièce | Rev. 0 | 2 |
| 5412EALBU201606 | | |

| Qty | Part Number | Rev | Description |
|------------|------------------|-----|---|
| 1 | 880 PP | 0 | Self Adhesive Print Pocket |
| 1 | STK-K-01800 | 0 | 5412 ES Accessory Kit |
| 4 | STK-Q-03001 | 1 | M5 x 8mm Stainless Steel Phillips Flat Head Screw |
| 1 | 5412EALBU201606C | 0 | 5412EALBU 20" x 16" Cover |
| 2 | STK-Q-07610 | 7 | M8 Plastic Spacer 22.2mm |
| 4 | STK-Q-07310 | 2 | Flange Lock Nut M8 |
| 1 | 881 SP2016 | 0 | 881 SP - Inner Panel |
| 2 | STK-Q-07615 | 0 | Inner Panel Support Bracket |
| 1 | 5412EALBU201606B | 0 | 5412EALBU 20" x 16" x 6" Body |
| Parts List | | | |

This drawing is confidential and must not be reproduced or used without the consent of EXM

Ce dessin est confidentiel et ne doit pas être reproduit ou utilisé sans le consentement de EXM

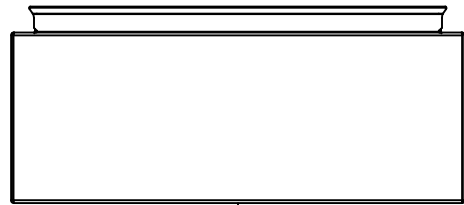

TOP

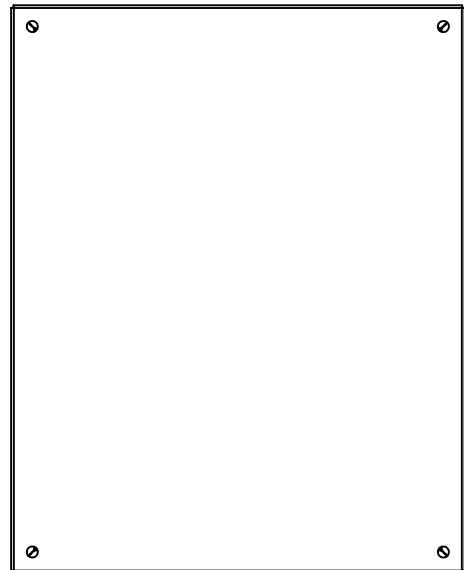

BACK

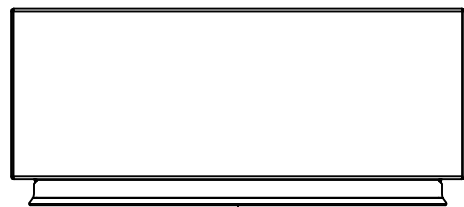

BOTTOM

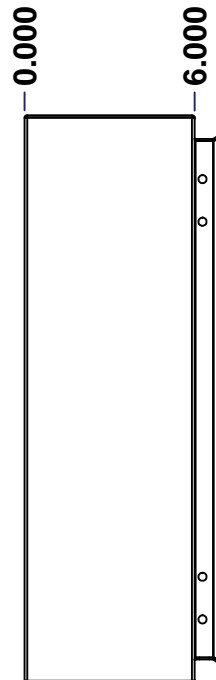

LEFT

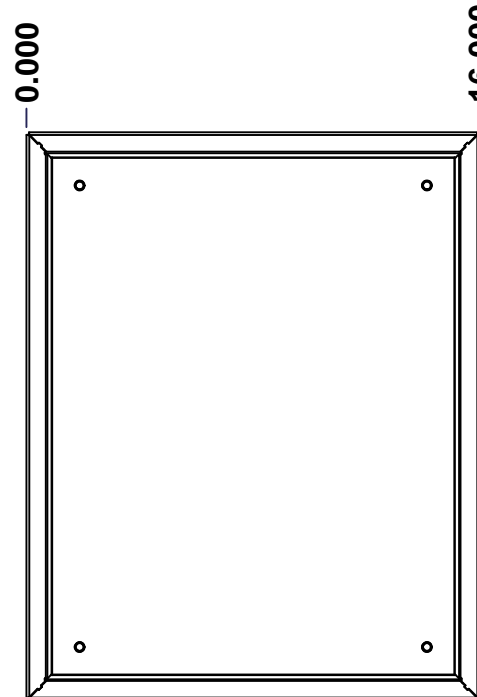

FRONT

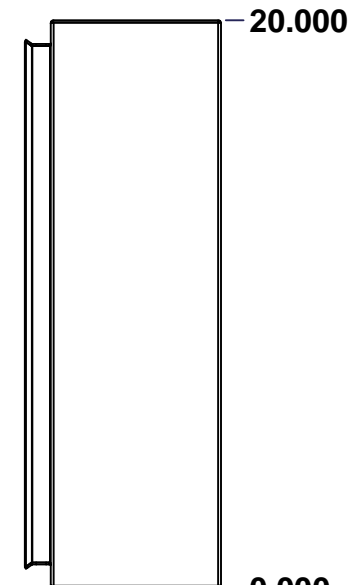

RIGHT

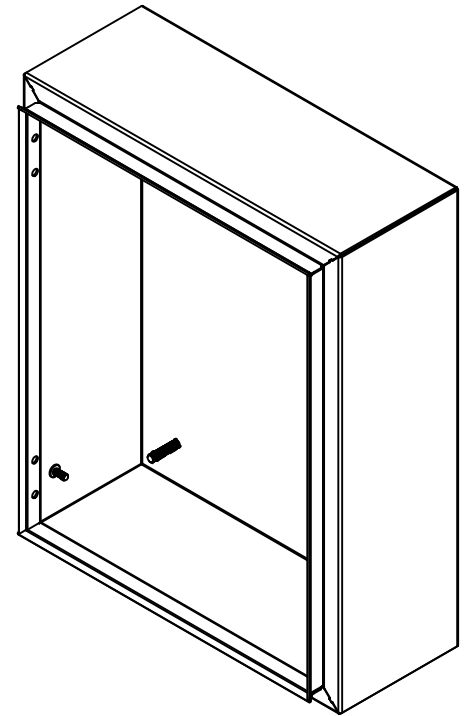

Isometric View



Tél: (450) 979-4373
 Fax: (450) 979-4626
www.exmweb.com

Flatness
Aplatissement

Max 3.0mm

Projection

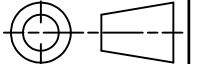

| | |
|---------------------------------------|------------------|
| Customer Client | Date |
| Drawn By / Dessiné Par: BoxCad: Annie | Date: 10/03/2015 |

Material / Matière: Aluminum 5052-H32 (1.7mm)

Color / Couleur: Asa-61 Grey Finish / Fini: Smooth

Description: 5412EALBU 20" x 16" x 6" Body Detail Rev.

| | | |
|---|--------|-------|
| Part Number / Numéro Pièce: 5412EALBU201606B | Rev. 0 | 1 / 7 |
|---|--------|-------|

SEE BILL OF MATERIAL ON LAST PAGE

This drawing is confidential and must not be reproduced or used without the consent of EXM

Ce dessin est confidentiel et ne doit pas être reproduit ou utilisé sans le consentement de EXM

| STANDARD FEATURES ARE NOT LISTED IN THIS HOLE TABLE | | | |
|---|-------|-------|-----------------------------|
| HOLE TABLE - LEFT VIEW (CUSTOM FEATURE ONLY) | | | |
| CUT-OUT | XDIM | YDIM | DESCRIPTION |
| 1 | 4.500 | 2.000 | GND STUD M6 x 16mm (Inside) |

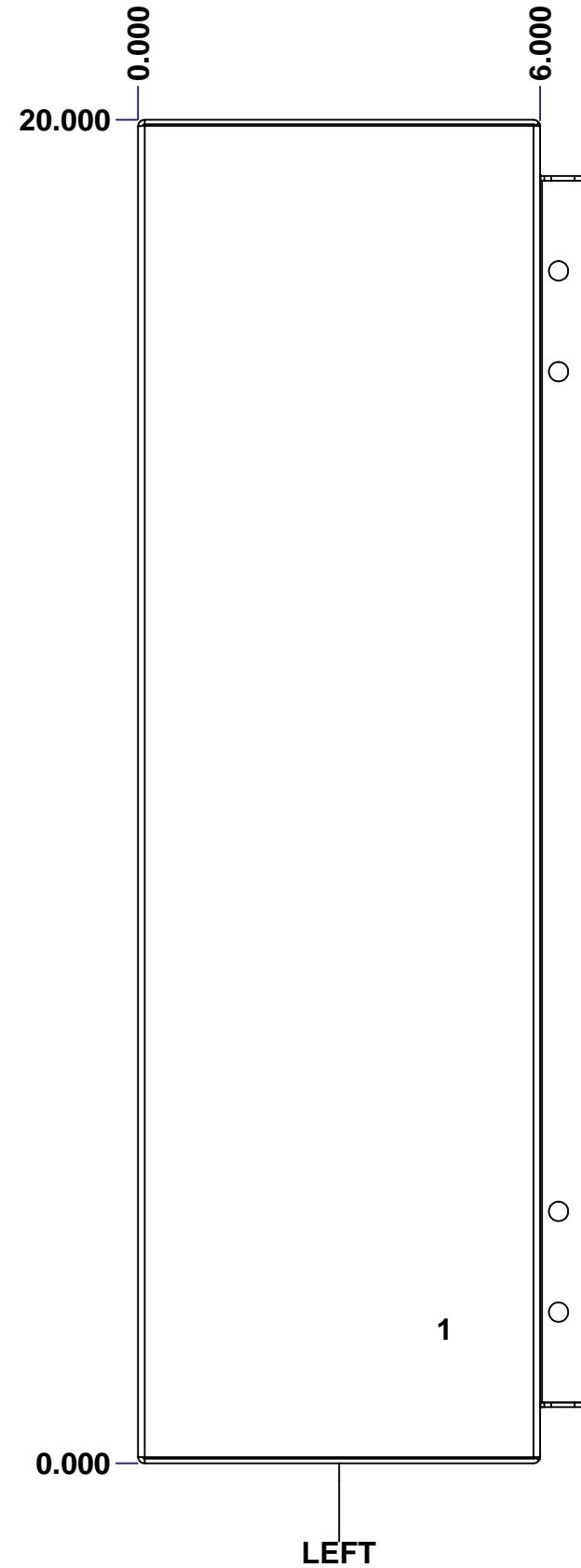

| | | | | |
|--|-------------------------------|--|----------|-------|
| | Description | | Status | |
| | 5412EALBU 20" x 16" x 6" Body | | | |
| | Part Number Numéro Pièce | | Rev. | |
| | 5412EALBU201606B | | 0 | 5 / 7 |

This drawing is confidential and must not be reproduced or used without the consent of EXM

Ce dessin est confidentiel et ne doit pas être reproduit ou utilisé sans le consentement de EXM

STANDARD FEATURES ARE NOT LISTED IN THIS HOLE TABLE

HOLE TABLE - BACK VIEW (CUSTOM FEATURE ONLY)

| CUT-OUT | XDIM | YDIM | DESCRIPTION |
|---------|--------|--------|----------------------------|
| 1 | 1.875 | 1.875 | IP STUD M8 x 35mm (Inside) |
| 2 | 1.875 | 18.125 | IP STUD M8 x 35mm (Inside) |
| 3 | 14.125 | 18.125 | IP STUD M8 x 35mm (Inside) |
| 4 | 14.125 | 1.875 | IP STUD M8 x 35mm (Inside) |

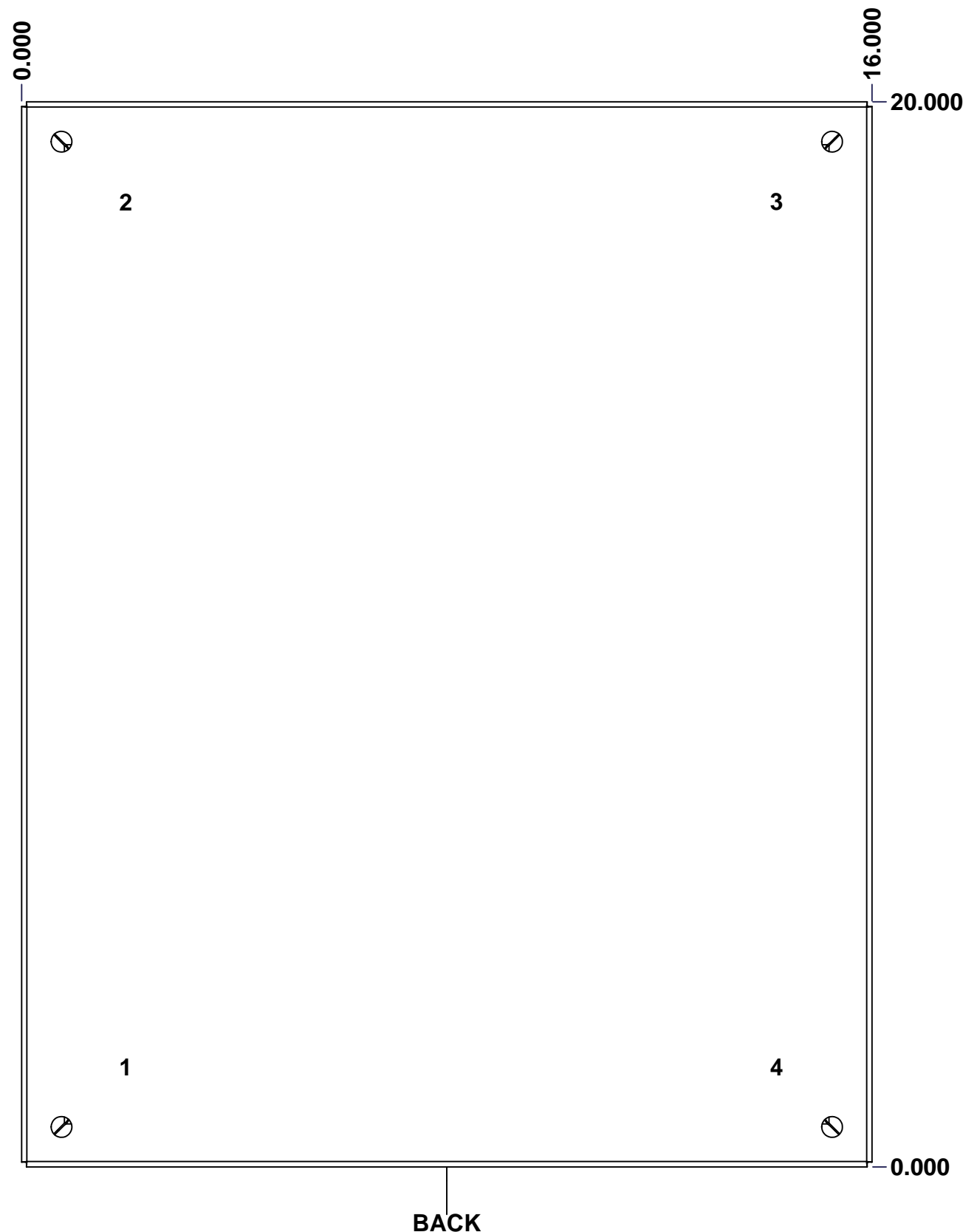

| | | | |
|--|-------------------------------|--|----------|
| | Description | | Status |
| | 5412EALBU 20" x 16" x 6" Body | | |
| | Part Number Numéro Pièce | | Rev. |
| | 5412EALBU201606B | | 0 |
| | | | 6 |
| | | | 7 |

This drawing is confidential and must not be reproduced or used without the consent of EXM

Ce dessin est confidentiel et ne doit pas être reproduit ou utilisé sans le consentement de EXM

| No. | Revisions | Date | By/Par |
|-----|-----------|------|--------|
| | | | |
| | | | |
| | | | |
| | | | |
| | | | |

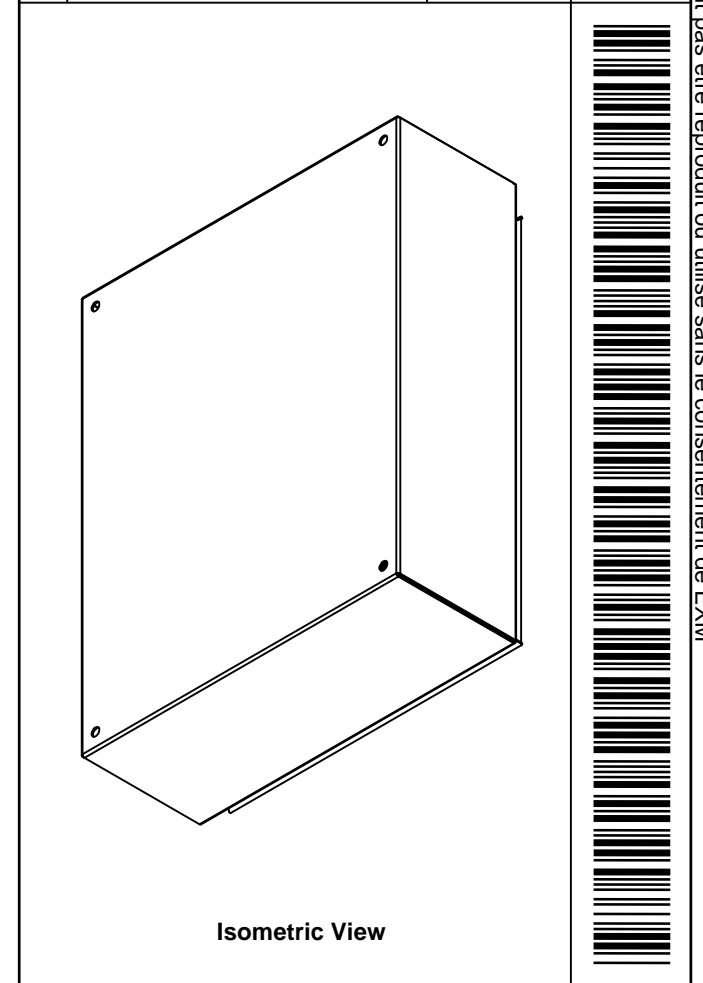

Isometric View

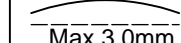
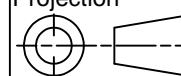

| | | |
|--|---------------------------|---|
|  Tél: (450) 979-4373 Fax: (450) 979-4626 www.exmweb.com | | Flatness Aplatissement  Max 3.0mm Projection  |
| Customer Client | Date | |
| Drawn By Dessiné Par | BoxCad: Annie | Date 10/03/2015 |
| Material Matière | Aluminum 5052-H32 (1.7mm) | |
| Color Couleur | Asa-61 Grey | Finish Fini Smooth |
| Description | | Detail Rev. |
| 5412EALBU 20" x 16" x 6" Body | | |
| Part Number Numéro Pièce | Rev. | 7 |
| 5412EALBU201606B | 0 | 7 |

| Qty | Part Number | Rev | Description |
|------------|--------------------|-----|-------------------------------------|
| 1 | STK-P-02400S | 0 | Powder Paint (Asa-61 Grey / Smooth) |
| 4 | STK-Q-16010 | 0 | Stud M8 x 35mm Aluminum |
| 1 | STK-Q-16090 | 0 | M6 x 16mm Aluminum Ground Stud |
| 1 | 5412EALBU201606B-P | 0 | 5412EALBU 20" x 16" x 6" Body Part |
| Parts List | | | |

This drawing is confidential and must not be reproduced or used without the consent of EXM

Ce dessin est confidentiel et ne doit pas être reproduit ou utilisé sans le consentement de EXM

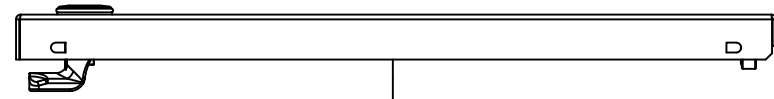

TOP

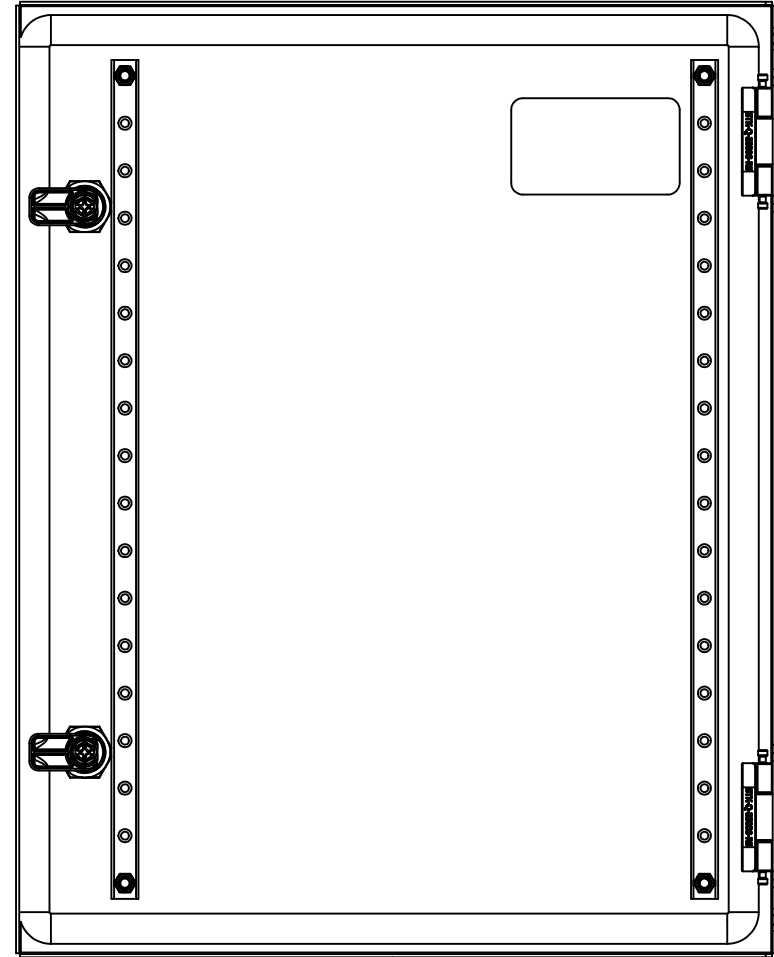

BACK

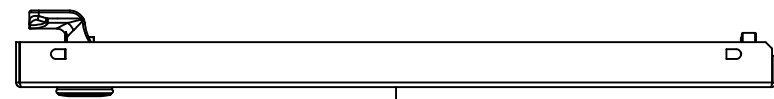

BOTTOM

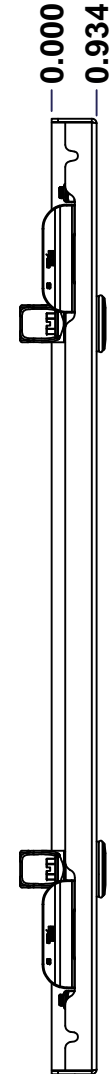

LEFT

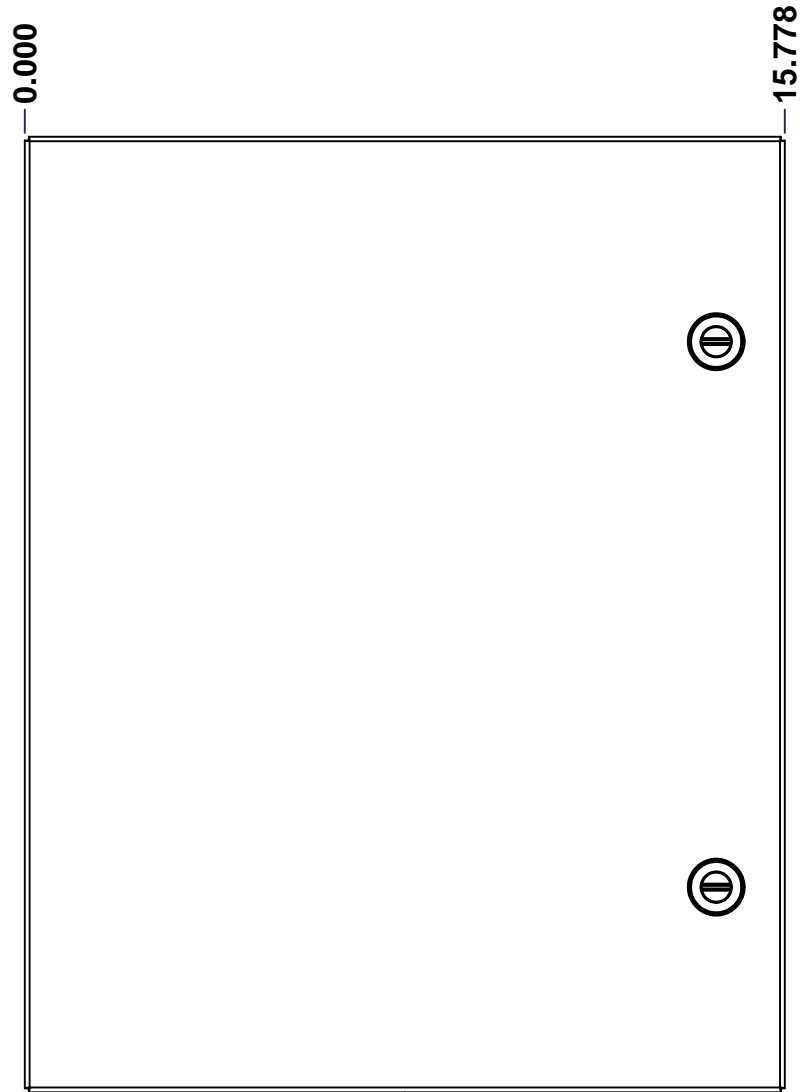

FRONT

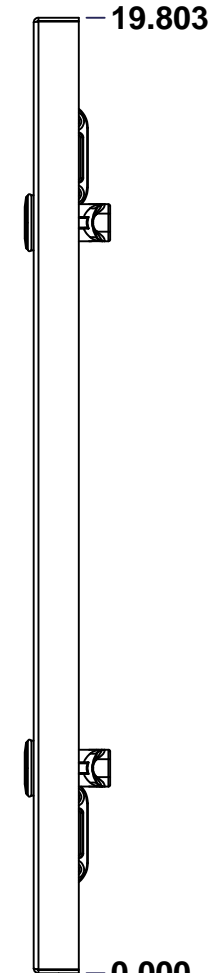

RIGHT

| No. | Revisions | Date | By/Par |
|-----|-----------|------|--------|
| | | | |
| | | | |
| | | | |
| | | | |
| | | | |

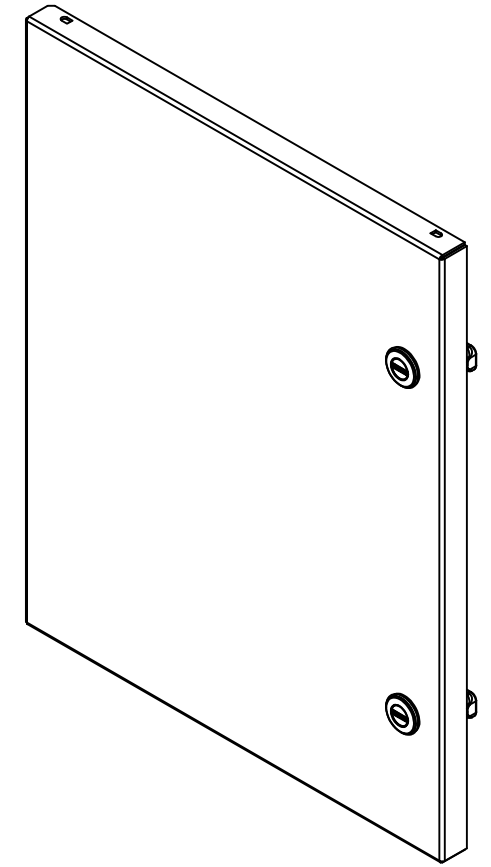

Isometric View



EXM
www.exm.com
Tél: (450) 979-4373
Fax: (450) 979-4626
www.exmweb.com

Flatness
Aplatissement
Max 3.0mm
Projection

Customer Client
Date
Drawn By / Dessiné Par: BoxCad: Annie
Date: 10/03/2015

Material / Matière: Aluminum 5052-H32 (1.7mm)

Color / Couleur: Asa-61 Grey
Finish / Fini: Smooth

Description: 5412EALBU 20" x 16" Cover
Detail Rev.

Part Number / Numéro Pièce: **5412EALBU201606C**
Rev. 0
1/3

SEE BILL OF MATERIAL ON LAST PAGE

This drawing is confidential and must not be reproduced or used without the consent of EXM

Ce dessin est confidentiel et ne doit pas être reproduit ou utilisé sans le consentement de EXM

| STANDARD FEATURES ARE NOT LISTED IN THIS HOLE TABLE | | | |
|---|--------|--------|-------------------------|
| HOLE TABLE - FRONT VIEW (CUSTOM FEATURE ONLY) | | | |
| CUT-OUT | XDIM | YDIM | DESCRIPTION |
| 1 | 1.486 | 1.535 | STUD M6 x 18mm (Inside) |
| 2 | 1.486 | 18.268 | STUD M6 x 18mm (Inside) |
| 3 | 13.517 | 18.268 | STUD M6 x 18mm (Inside) |
| 4 | 13.517 | 1.535 | STUD M6 x 18mm (Inside) |

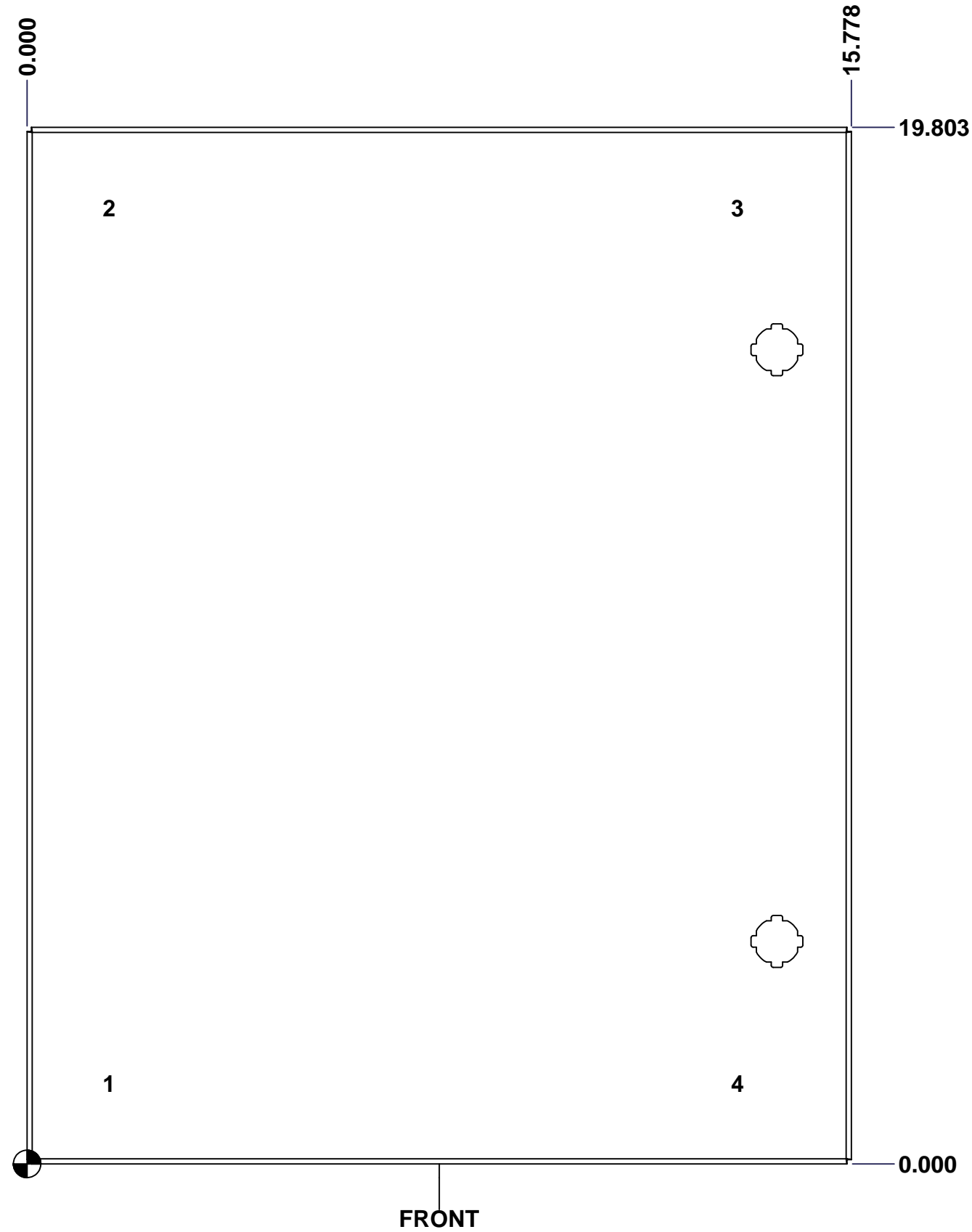

FRONT

| | | |
|--|-----------------------------|----------|
| | Description | Status |
| | 5412EALBU 20" x 16" Cover | (NULL) |
| | Part Number Numéro Pièce | Rev. |
| | 5412EALBU201606C | 0 |
| | | 2 |
| | | 3 |

This drawing is confidential and must not be reproduced or used without the consent of EXM

Ce dessin est confidentiel et ne doit pas être reproduit ou utilisé sans le consentement de EXM

| No. | Revisions | Date | By/Par |
|-----|-----------|------|--------|
| | | | |
| | | | |
| | | | |
| | | | |
| | | | |

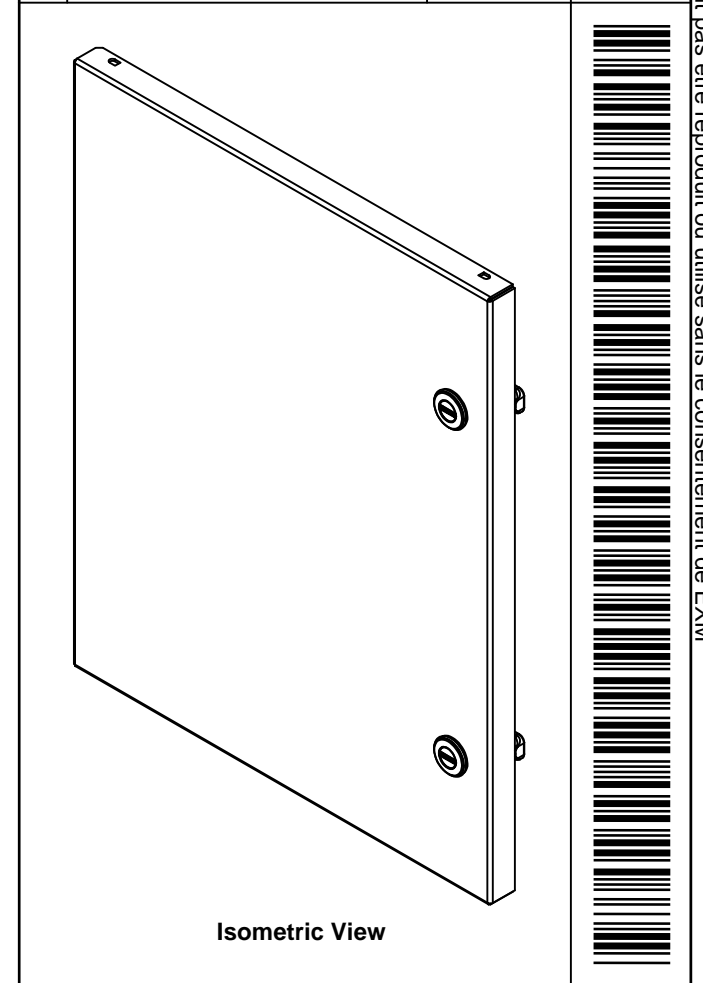

| Qty | Part Name | Rev | Description |
|-----|--------------------|-------|--|
| 1 | STK-P-02400S | 0 | Powder Paint (Asa-61 Grey / Smooth) |
| 1 | STK-S-00100 | 0.1.1 | 3.5" x 2" Silver Milar Flexcon Sticker |
| 2 | STK-Q-46020-20 | 3 | 5412 ES Vertical Door Stiffener 20" |
| 4 | STK-Q-16060 | 0 | Stud M6 x 18mm Aluminum |
| 1 | | | |
| 2 | STK-Q-33106 | 0 | 5412 ESSBU Buttable Hinge (Cover Part) |
| 1 | | | |
| 1 | 5412EALBU201606G | 0 | 5412EALBU 20" x 16" Cover Gasket |
| 1 | 5412EALBU201606C-P | 0 | 5412EALBU 20" x 16" Cover Part |
| 2 | 880 SCQ4-SL | 0 | 5412 ES 1/4 Turn Lock |
| 4 | STK-Q-07220 | 1 | M6 Nylon Insert Lock Nut |
| | | | |
| | | | |
| | | | |

Parts List

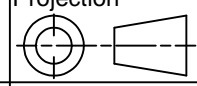
| | | |
|--|-----------------------|---|
|  Tél: (450) 979-4373 Fax: (450) 979-4626 www.exmweb.com | | Flatness Aplatissement Max 3.0mm Projection  |
| Customer Client | Date | |
| Drawn By / Dessiné Par: BoxCad: Annie | Date: 10/03/2015 | |
| Material / Matière: Aluminum 5052-H32 (1.7mm) | | |
| Color / Couleur: Asa-61 Grey | Finish / Fini: Smooth | |
| Description: 5412EALBU 20" x 16" Cover | | Detail Rev. |
| Part Number / Numéro Pièce: 5412EALBU201606C | Rev. 0 | 3 |

This drawing is confidential and must not be reproduced or used without the consent of EXM

Ce dessin est confidentiel et ne doit pas être reproduit ou utilisé sans le consentement de EXM

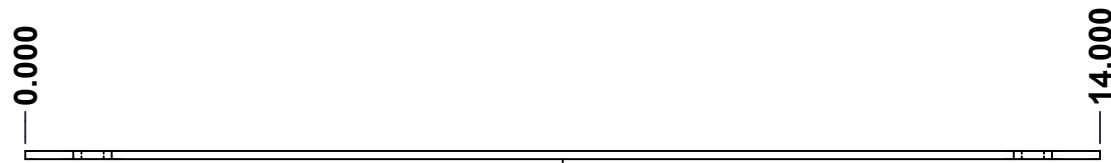

TOP

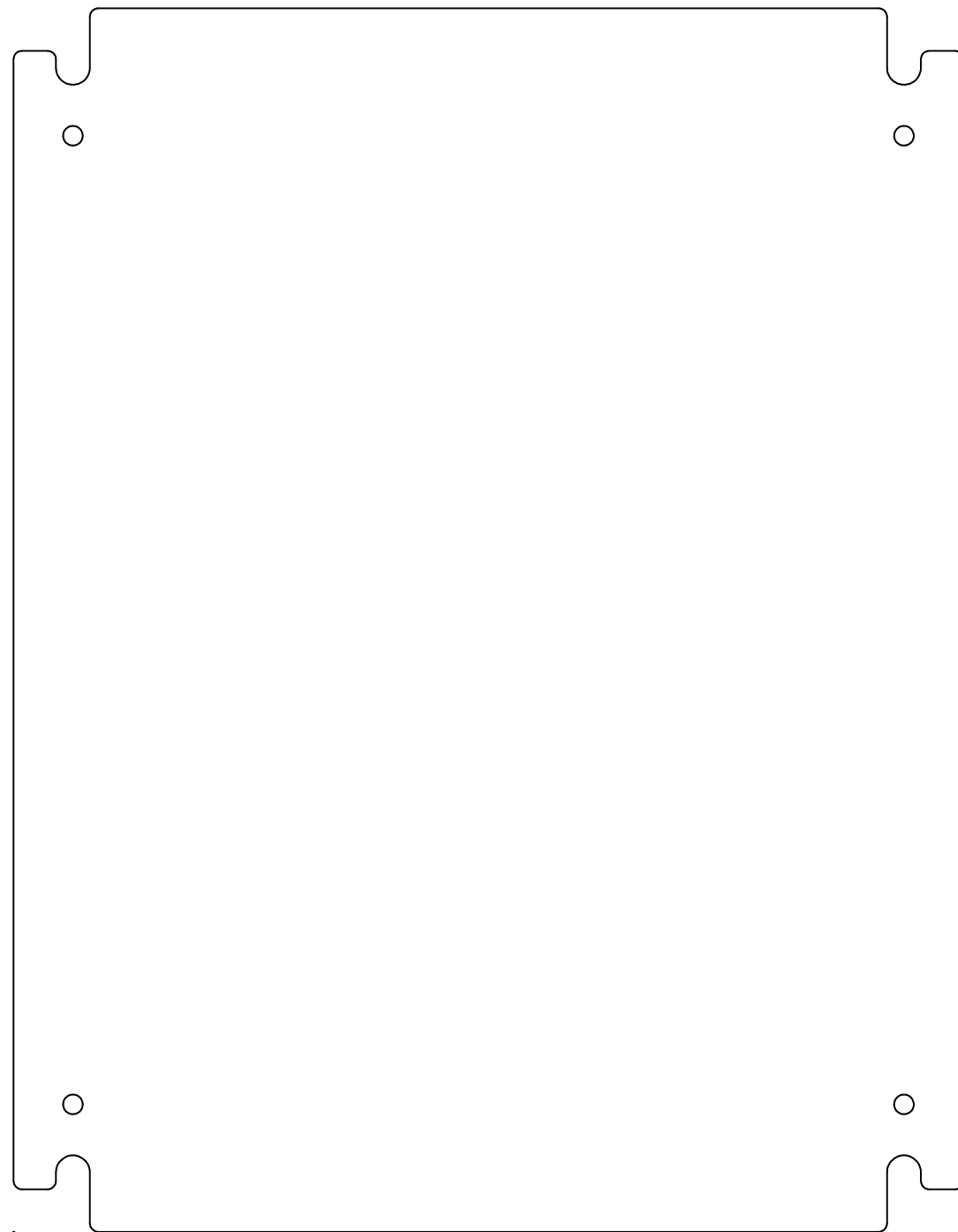

FRONT

18.000

0.000

RIGHT

| No. | Revisions | Date | By/Par |
|-----|-----------|------|--------|
| | | | |
| | | | |
| | | | |
| | | | |
| | | | |

Isometric View

| | | |
|--|---------------|--|
| Tél: (450) 979-4373 Fax: (450) 979-4626 www.exmweb.com | | Flatness Aplatissement Max 3.0mm Projection |
| Customer Client | Date | |
| Drawn By Dessiné Par | BoxCad | Date 1/23/2007 |
| Material Matière | See Part List | |
| Color Couleur | See Part List | Finish Fini See Part List |
| Description | | Detail Rev. |
| 881 SP - Inner Panel | | |
| Part Number Numéro Pièce | | Rev. 1 |
| 881 SP2016 | | 0 2 |

| Qty | Part Number | Rev | Description | Material | Color | Finish |
|-----|--------------|-----|-------------------------------|------------------------|---------------|--------|
| 1 | STK-P-02401S | 0 | Powder Paint (White / Smooth) | Polyester-Epoxy Hybrid | White RAL9003 | Smooth |
| 1 | 881 SP2016-P | 0 | 881 SP - Inner Panel Part | 12 Ga H.R.P. & O. | White | Smooth |

Parts List

This drawing is confidential and must not be reproduced or used without the consent of EXM

Ce dessin est confidentiel et ne doit pas être reproduit ou utilisé sans le consentement de EXM

| Table 1 | | | FRONT VIEW |
|---------|--------|--------|--------------------------|
| CUT-OUT | XDIM | YDIM | DESCRIPTION |
| 1 | 0.875 | 1.875 | GROUND HOLE (RND Ø0.290) |
| 2 | 13.125 | 1.875 | GROUND HOLE (RND Ø0.290) |
| 3 | 0.875 | 16.125 | GROUND HOLE (RND Ø0.290) |
| 4 | 13.125 | 16.125 | GROUND HOLE (RND Ø0.290) |

All knockouts are actual size / Les disques défonçables sont grandeur réel

| No. | Revisions | Date | By/Par |
|-----|-----------|------|--------|
| | | | |
| | | | |
| | | | |
| | | | |
| | | | |
| | | | |

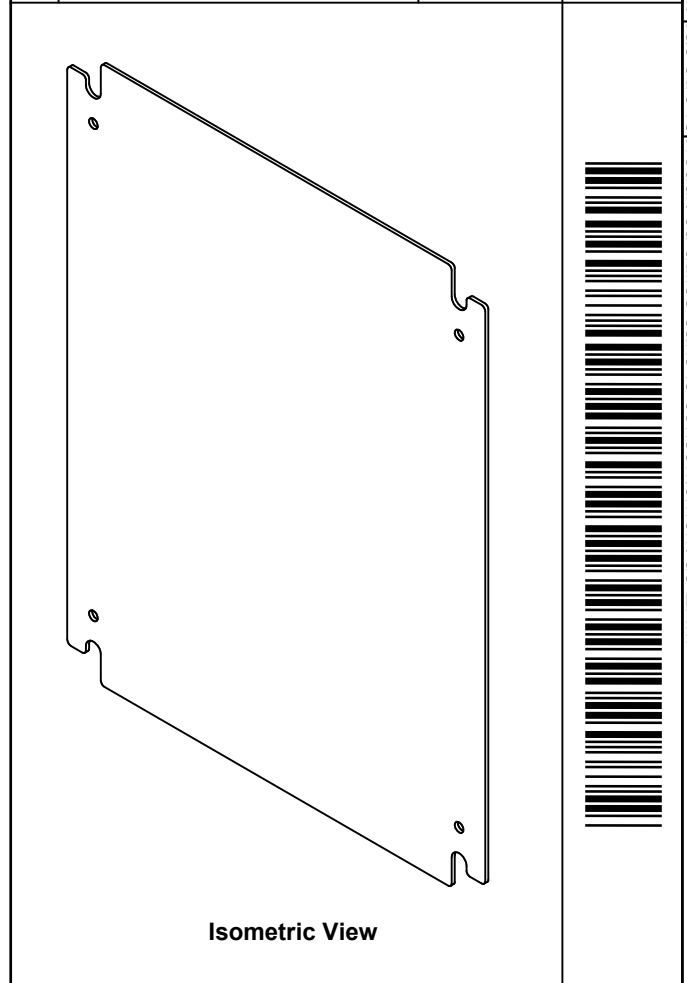
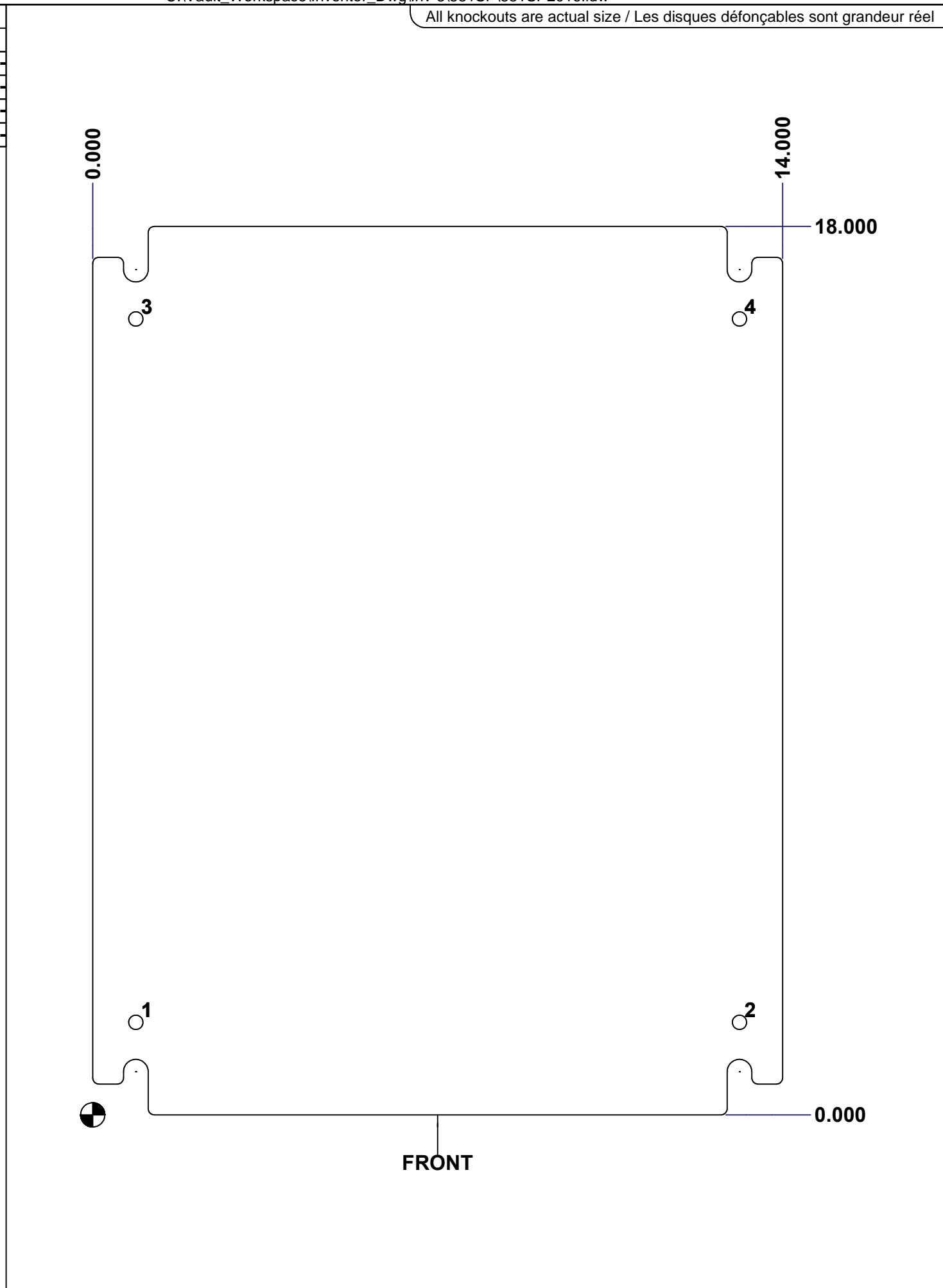

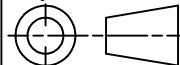
| | | |
|--|------------------------------|---|
|  Tél: (450) 979-4373 Fax: (450) 979-4626 www.exmweb.com | | Flatness Aplatissement Max 3.0mm |
| Customer Client | | Projection  |
| Drawn By Dessiné Par BoxCad | | Date 1/23/2007 |
| Material Matière See Part List | | |
| Color Couleur See Part List | Finish Fini See Part List | |
| Description 881 SP - Inner Panel | | Detail Rev. |
| Part Number Numéro Pièce 881 SP2016 | | Rev. 2 0 |