

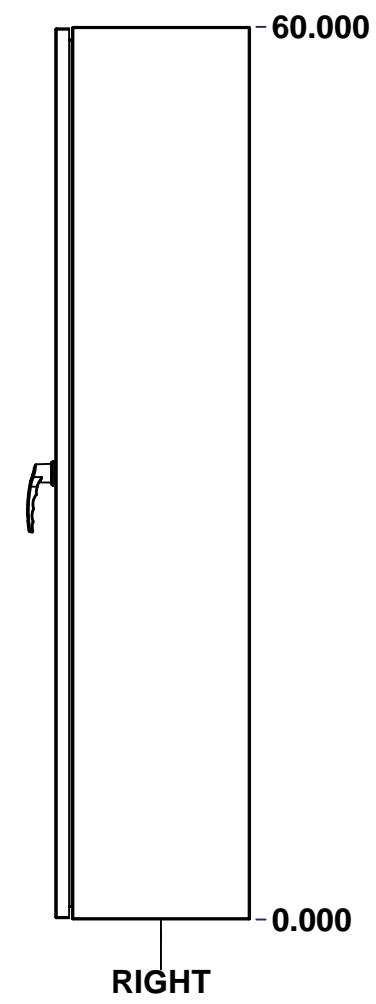

This drawing is confidential and must not be reproduced or used without the consent of EXM

Ce dessin est confidentiel et ne doit pas être reproduit ou utilisé sans le consentement de EXM

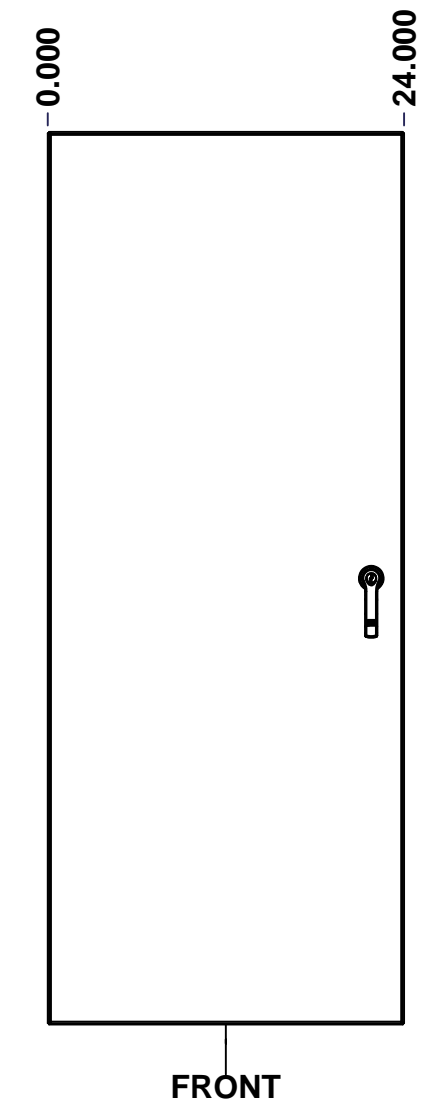
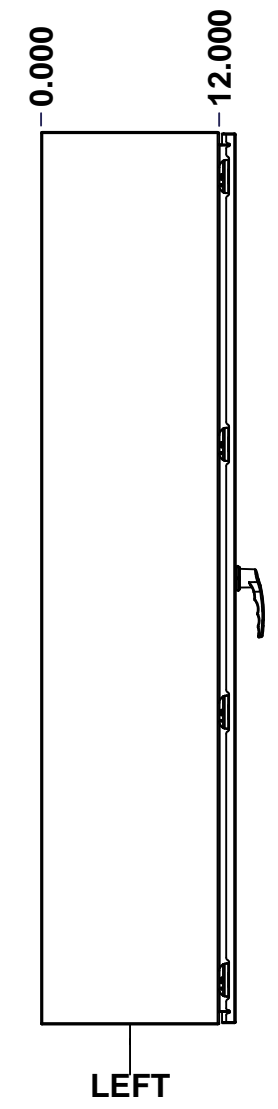
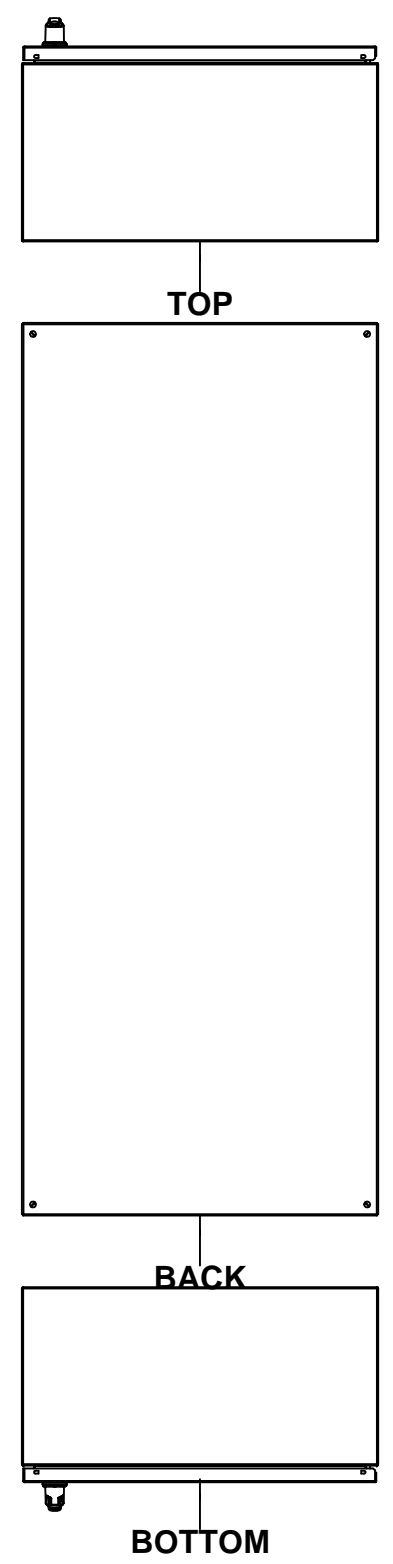
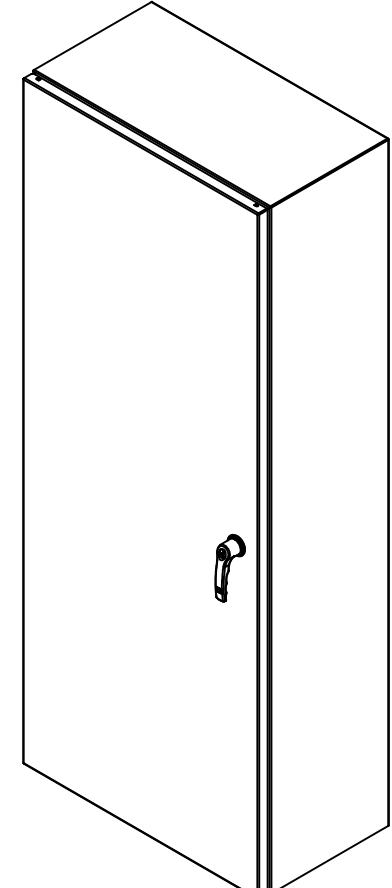

No.	Revisions	Date	By/Par



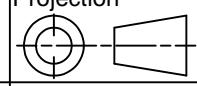

Isometric View

 Tél: (450) 979-4373 Fax: (450) 979-4626 www.exmweb.com		Flatness Aplatissement	
		Max 3.0mm	
Customer Client		Date	
Drawn By Dessiné Par BoxCad: Annie		Date 31/03/2015	
Material Matière Aluminum 5052-H32 (1.7mm)		Projection	
Color Couleur Asa-61 Grey		 Finish Fini Smooth	
Description 5412EALBU 60" x 24" x 12" Assembly		Detail Rev.	
Part Number Numéro Pièce 5412EALBU602412		Rev. 0	1 2

SEE BILL OF MATERIAL ON LAST PAGE

This drawing is confidential and must not be reproduced or used without the consent of EXM

Ce dessin est confidentiel et ne doit pas être reproduit ou utilisé sans le consentement de EXM

NOTE	
ITEM	DESCRIPTION
1	NEMA 4X Enclosure
2	C/W Standard ground studs on box and cover
3	C/W Standard door stiffener
4	C/W Standard inner panel (Sold seperately)
5	C/W Standard inner panel mounting studs

No.	Revisions	Date	By/Par

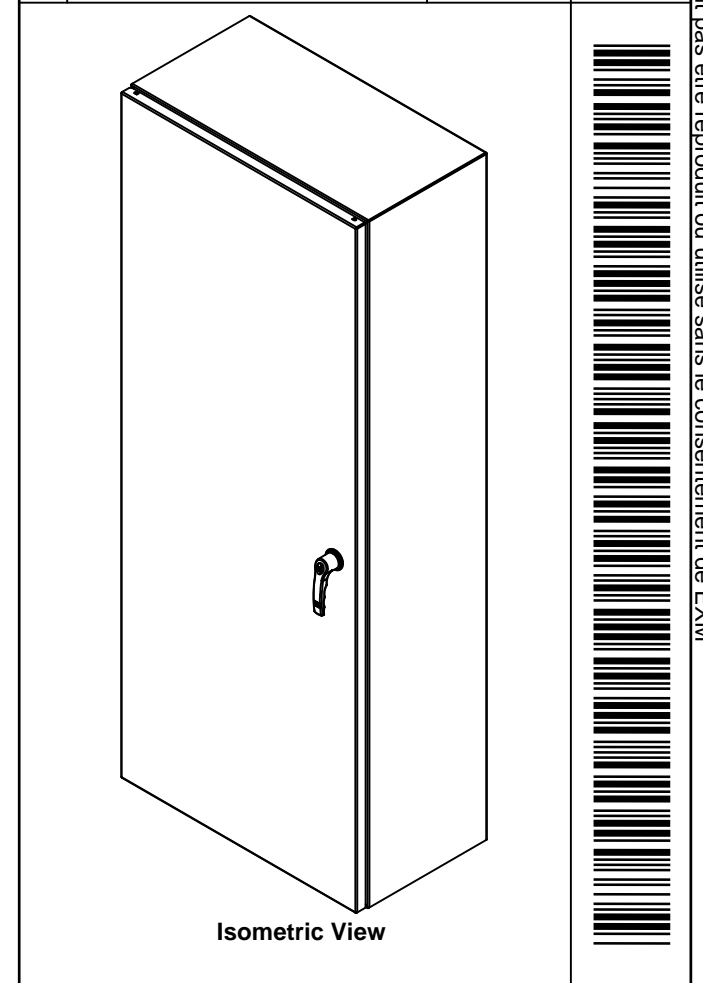

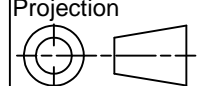
 Tél: (450) 979-4373 Fax: (450) 979-4626 www.exmweb.com		Flatness Aplatissement Max 3.0mm Projection 
Customer Client	Date	Date 31/03/2015
Drawn By Dessiné Par	BoxCad: Annie	
Material Matière	Aluminum 5052-H32 (1.7mm)	
Color Couleur	Asa-61 Grey	Finish Fini Smooth
Description	5412EALBU 60" x 24" x 12" Assembly	
Part Number Numéro Pièce	Rev. 0	2

Qty	Part Number	Rev	Description
1	880 PP	0	Self Adhesive Print Pocket
1	STK-K-01800	0	5412 ES Accessory Kit
8	STK-Q-03001	1	M5 x 8mm Stainless Steel Phillips Flat Head Screw
1	5412EALBU602412C	0	5412EALBU 60" x 24" Cover
4	STK-Q-07610	7	M8 Plastic Spacer 22.2mm
6	STK-Q-07310	2	Flange Lock Nut M8
1	881 SP6024	0	881 SP - Inner Panel
2	STK-Q-07615	0	Inner Panel Support Bracket
1	5412EALBU602412B	0	5412EALBU 60" x 24" x 12" Body
Parts List			

This drawing is confidential and must not be reproduced or used without the consent of EXM

Ce dessin est confidentiel et ne doit pas être reproduit ou utilisé sans le consentement de EXM

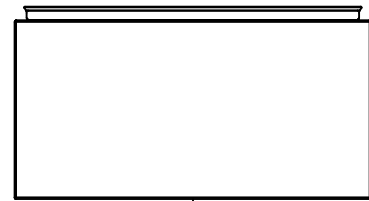

TOP

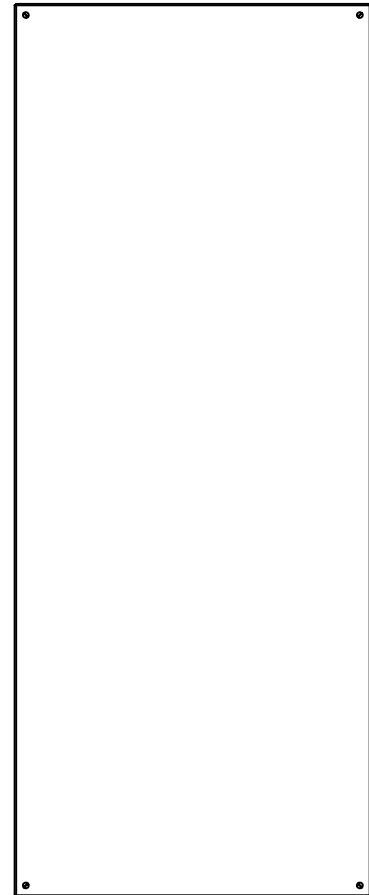

BACK

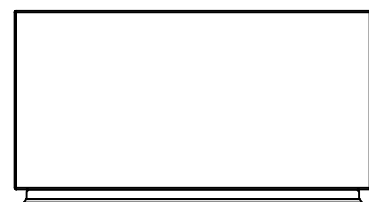

BOTTOM

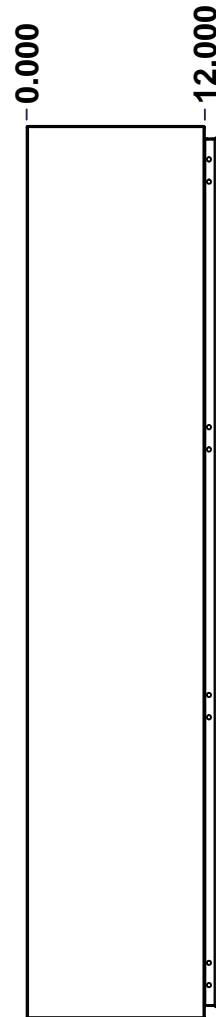

LEFT

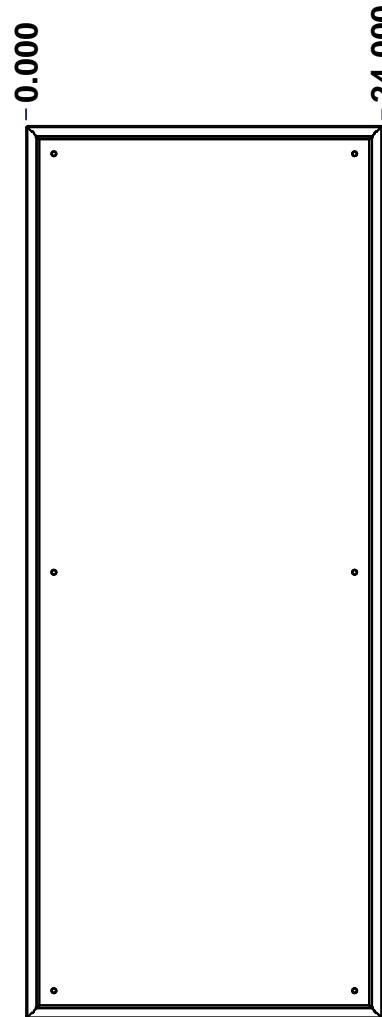

FRONT

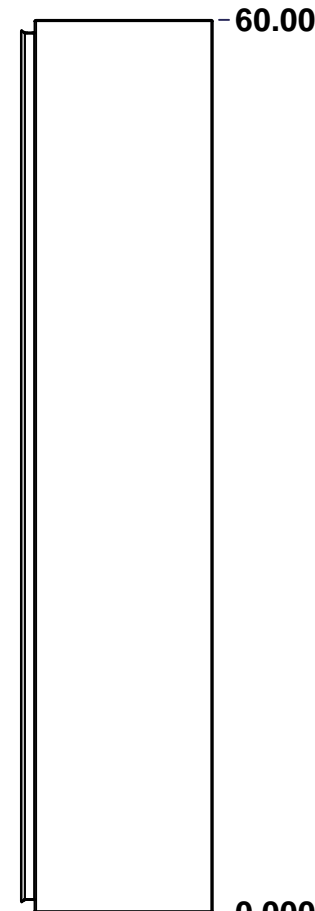

RIGHT

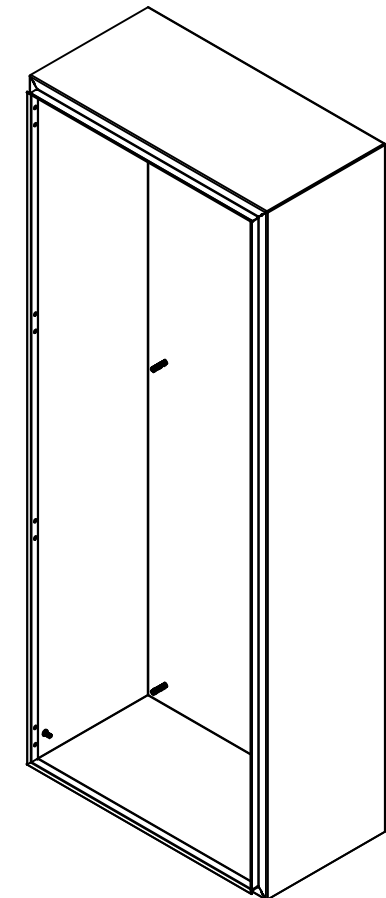

Isometric View

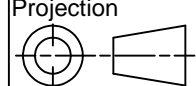

No.	Revisions	Date	By/Par

 Tél: (450) 979-4373 Fax: (450) 979-4626 www.exmweb.com		Flatness Aplatissement Max 3.0mm Projection 
Customer Client	Date	
Drawn By Dessiné Par	BoxCad: Annie	Date 31/03/2015
Material Matière	Aluminum 5052-H32 (1.7mm)	
Color Couleur	Asa-61 Grey	Finish Fini Smooth
Description	Detail Rev.	
5412EALBU 60" x 24" x 12" Body		
Part Number Numéro Pièce	Rev.	
5412EALBU602412B	0	1/7

SEE BILL OF MATERIAL ON LAST PAGE

This drawing is confidential and must not be reproduced or used without the consent of EXM

Ce dessin est confidentiel et ne doit pas être reproduit ou utilisé sans le consentement de EXM

STANDARD FEATURES ARE NOT LISTED IN THIS HOLE TABLE			
HOLE TABLE - LEFT VIEW (CUSTOM FEATURE ONLY)			
CUT-OUT	XDIM	YDIM	DESCRIPTION
1	10.500	2.000	GND STUD M6 x 16mm (Inside)

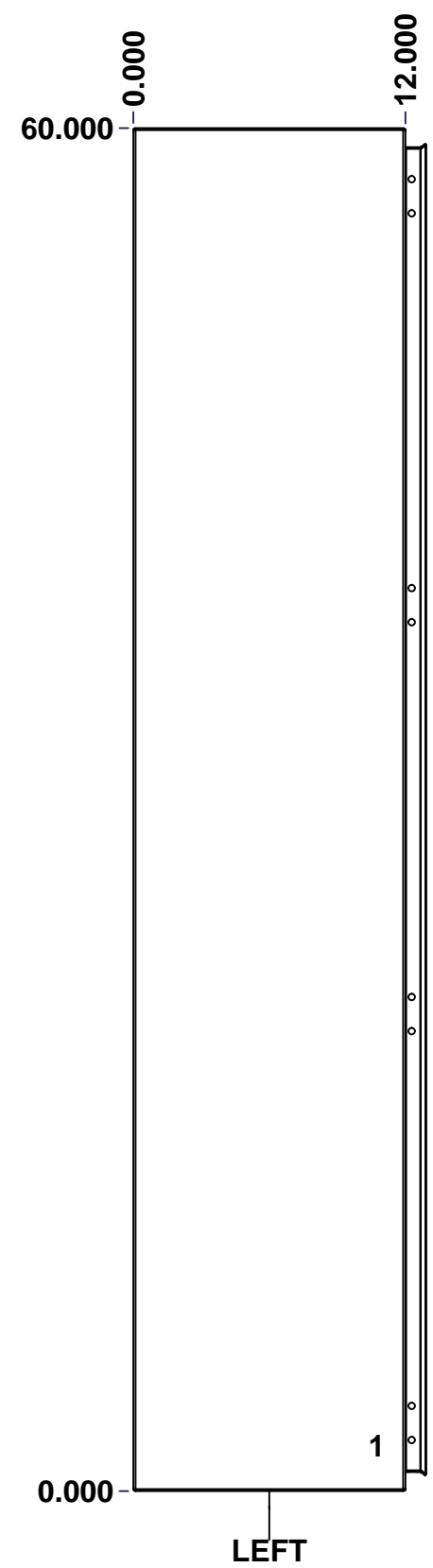

	Description	Status	
	5412EALBU 60" x 24" x 12" Body		
	Part Number Numéro Pièce	Rev.	
	5412EALBU602412B	0	5 7

This drawing is confidential and must not be reproduced or used without the consent of EXM

Ce dessin est confidentiel et ne doit pas être reproduit ou utilisé sans le consentement de EXM

STANDARD FEATURES ARE NOT LISTED IN THIS HOLE TABLE

HOLE TABLE - BACK VIEW (CUSTOM FEATURE ONLY)

CUT-OUT	XDIM	YDIM	DESCRIPTION
1	1.875	1.875	IP STUD M8 x 35mm (Inside)
2	1.875	58.125	IP STUD M8 x 35mm (Inside)
3	22.125	58.125	IP STUD M8 x 35mm (Inside)
4	22.125	1.875	IP STUD M8 x 35mm (Inside)
5	1.875	30.000	IP STUD M8 x 35mm (Inside)
6	22.125	30.000	IP STUD M8 x 35mm (Inside)

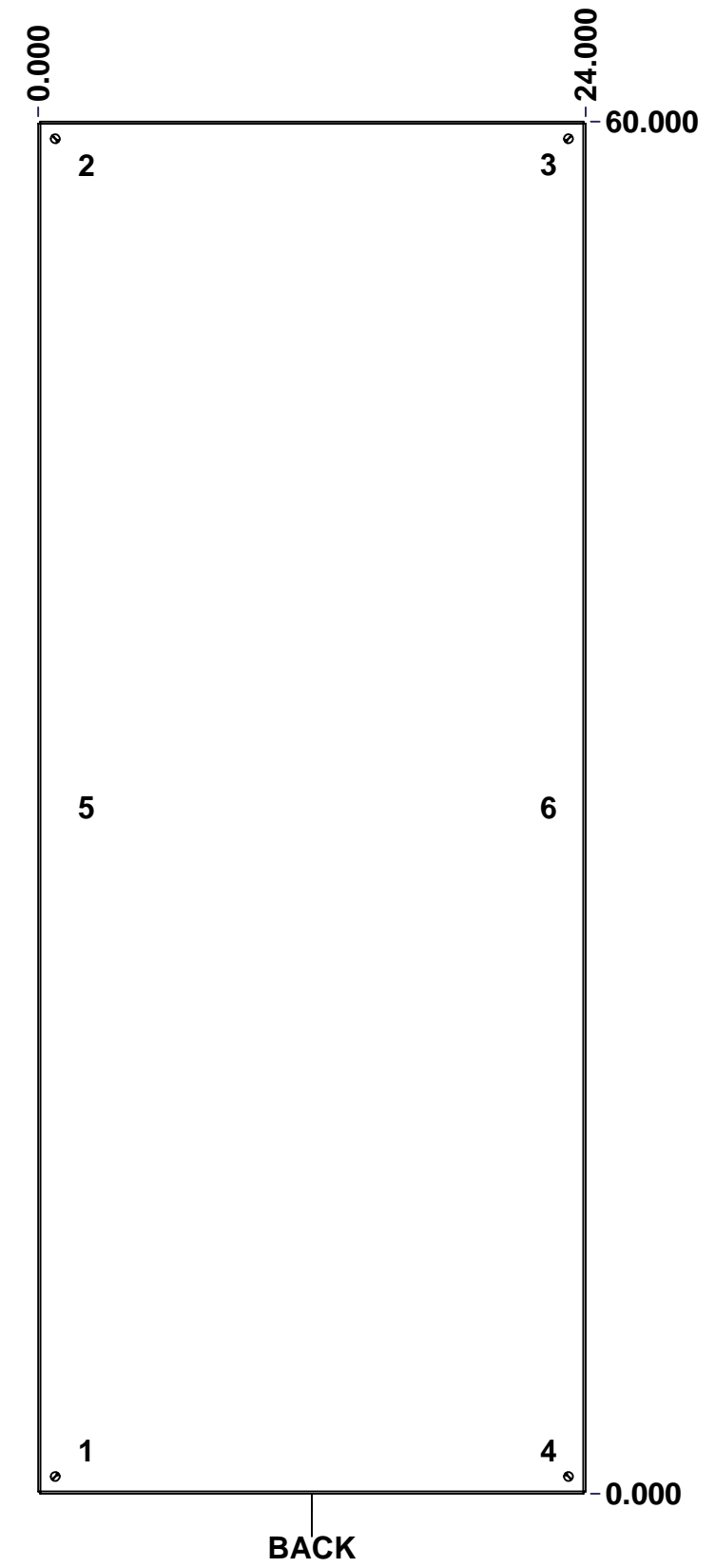

	Description		Status
	5412EALBU 60" x 24" x 12" Body		
	Part Number Numéro Pièce		Rev.
	5412EALBU602412B		0
			6 / 7

This drawing is confidential and must not be reproduced or used without the consent of EXM

Ce dessin est confidentiel et ne doit pas être reproduit ou utilisé sans le consentement de EXM

No.	Revisions	Date	By/Par

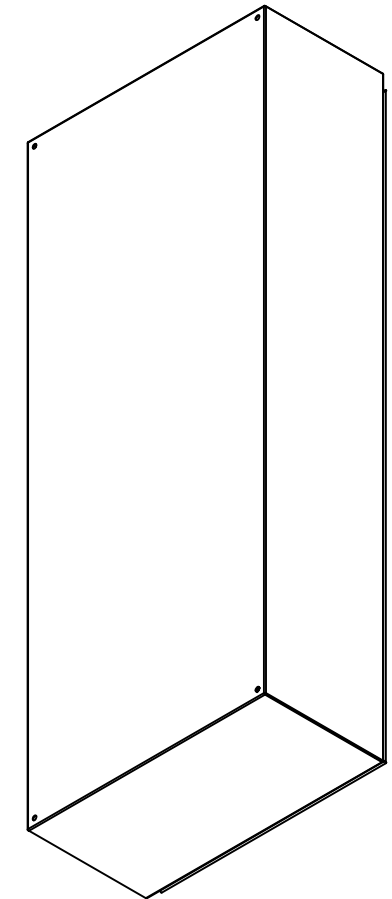

Isometric View

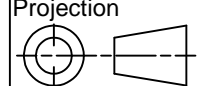

 Tél: (450) 979-4373 Fax: (450) 979-4626 www.exmweb.com	Flatness Aplatissement Max 3.0mm
	Projection 
Customer Client	Date
Drawn By Dessiné Par BoxCad: Annie	Date 31/03/2015
Material Matière Aluminum 5052-H32 (1.7mm)	
Color Couleur Asa-61 Grey	Finish Fini Smooth
Description 5412EALBU 60" x 24" x 12" Body	
Part Number Numéro Pièce 5412EALBU602412B	Rev. 7 0

Qty	Part Number	Rev	Description
1	STK-P-02400S	0	Powder Paint (Asa-61 Grey / Smooth)
6	STK-Q-16010	0	Stud M8 x 35mm Aluminum
1	STK-Q-16090	0	M6 x 16mm Aluminum Ground Stud
1	5412EALBU602412B-P	0	5412EALBU 60" x 24" x 12" Body Part
Parts List			

This drawing is confidential and must not be reproduced or used without the consent of EXM

Ce dessin est confidentiel et ne doit pas être reproduit ou utilisé sans le consentement de EXM

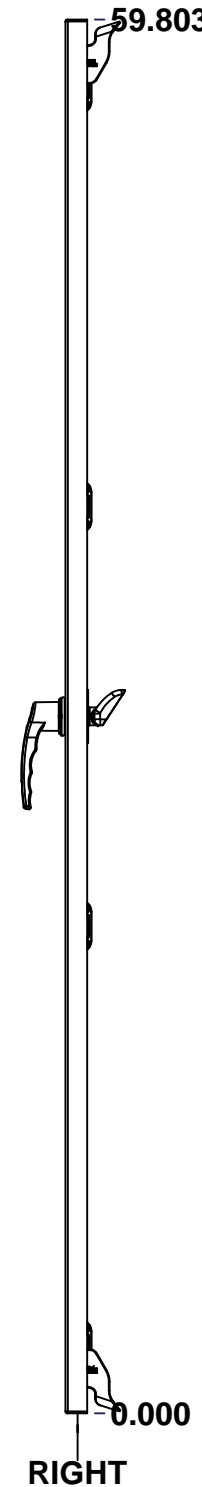
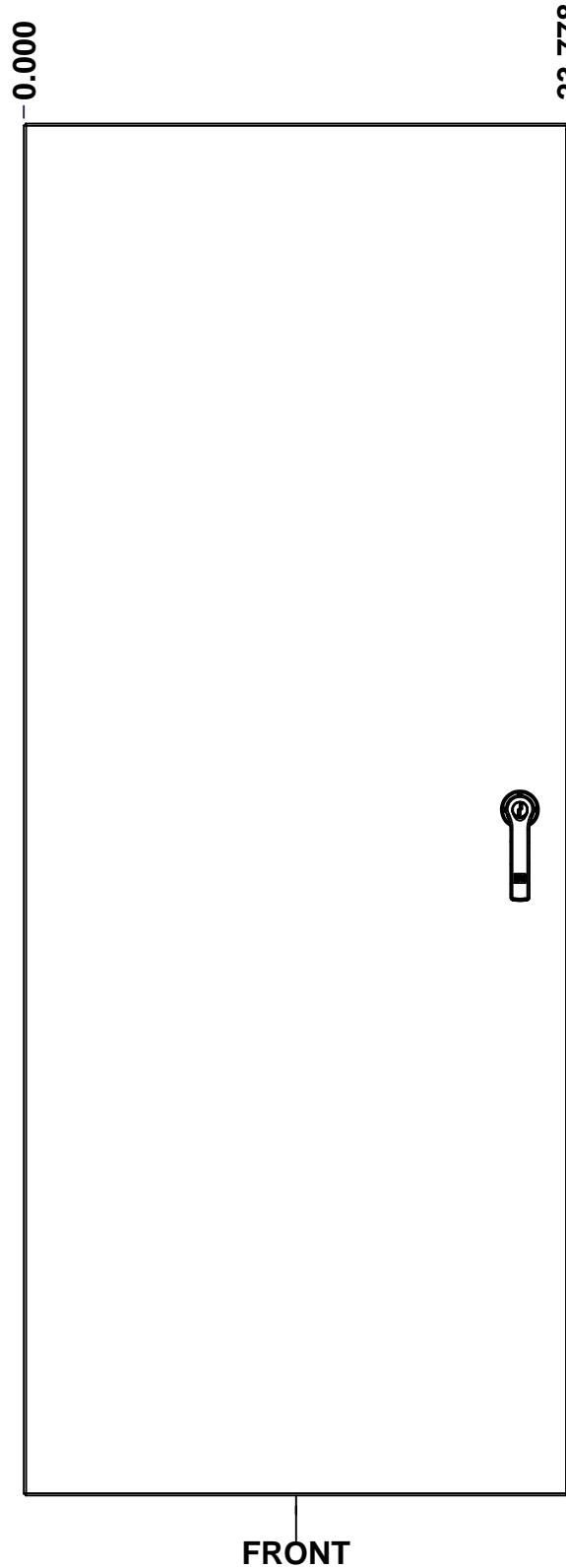
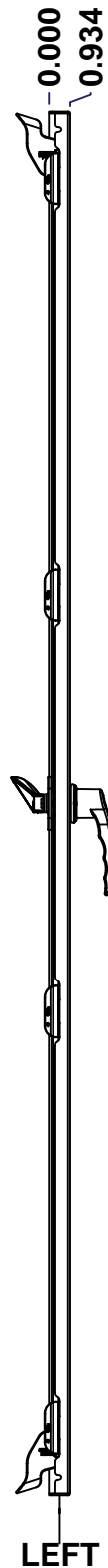
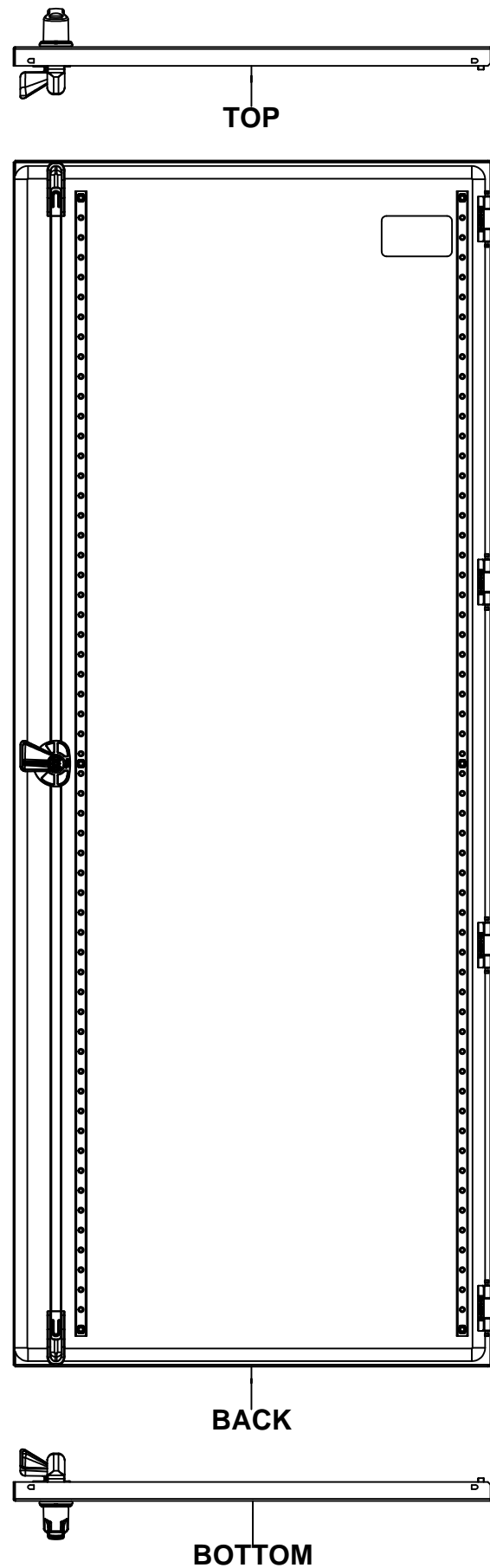

No.	Revisions	Date	By/Par

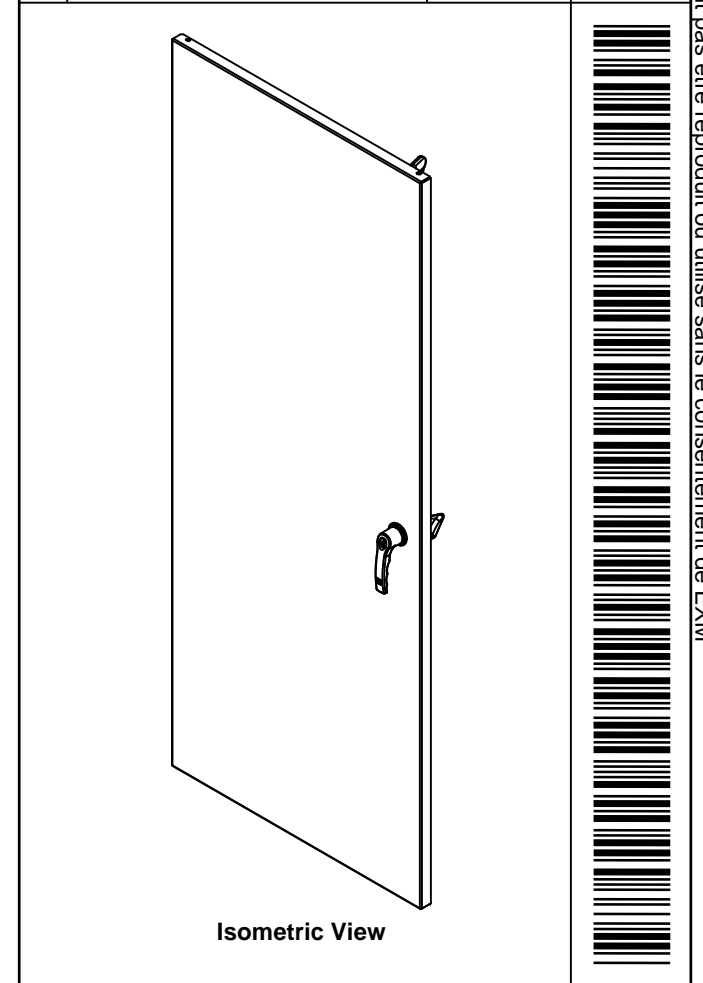

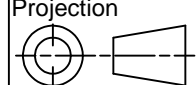
 Tél: (450) 979-4373 Fax: (450) 979-4626 www.exmweb.com		Flatness Aplatissement Max 3.0mm Projection 
Customer Client		Date
Drawn By / Dessiné Par	BoxCad: Annie	Date 31/03/2015
Material / Matière	Aluminum 5052-H32 (1.7mm)	
Color / Couleur	Asa-61 Grey	Finish / Fini: Smooth
Description	5412EALBU 60" x 24" Cover	
Part Number / Numéro Pièce	5412EALBU602412C	Detail Rev. / Rev. 1
		3

SEE BILL OF MATERIAL ON LAST PAGE

This drawing is confidential and must not be reproduced or used without the consent of EXM

Ce dessin est confidentiel et ne doit pas être reproduit ou utilisé sans le consentement de EXM

STANDARD FEATURES ARE NOT LISTED IN THIS HOLE TABLE			
HOLE TABLE - FRONT VIEW (CUSTOM FEATURE ONLY)			
CUT-OUT	XDIM	YDIM	DESCRIPTION
1	1.486	1.850	STUD M6 x 18mm (Inside)
2	1.486	57.953	STUD M6 x 18mm (Inside)
3	20.423	57.953	STUD M6 x 18mm (Inside)
4	20.423	1.850	STUD M6 x 18mm (Inside)
5	1.486	29.902	STUD M6 x 18mm (Inside)
6	20.423	29.902	STUD M6 x 18mm (Inside)
7	21.803	54.896	CLOSING BAR STUD (Inside)
8	21.803	4.907	CLOSING BAR STUD (Inside)

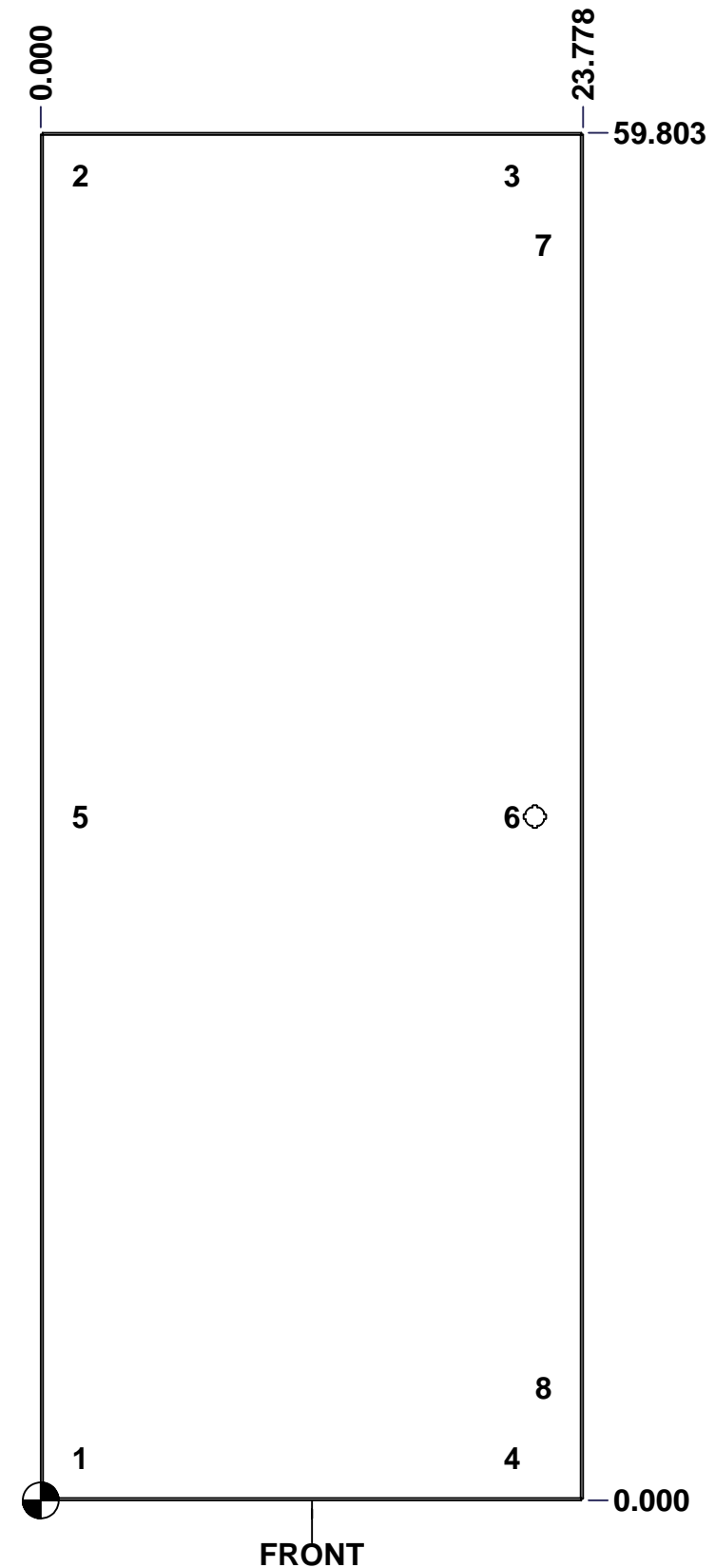

	Description	Status
	5412EALBU 60" x 24" Cover	(NULL)
	Part Number Numéro Pièce	Rev.
	5412EALBU602412C	0
		2
		3

This drawing is confidential and must not be reproduced or used without the consent of EXM

Ce dessin est confidentiel et ne doit pas être reproduit ou utilisé sans le consentement de EXM

No.	Revisions	Date	By/Par

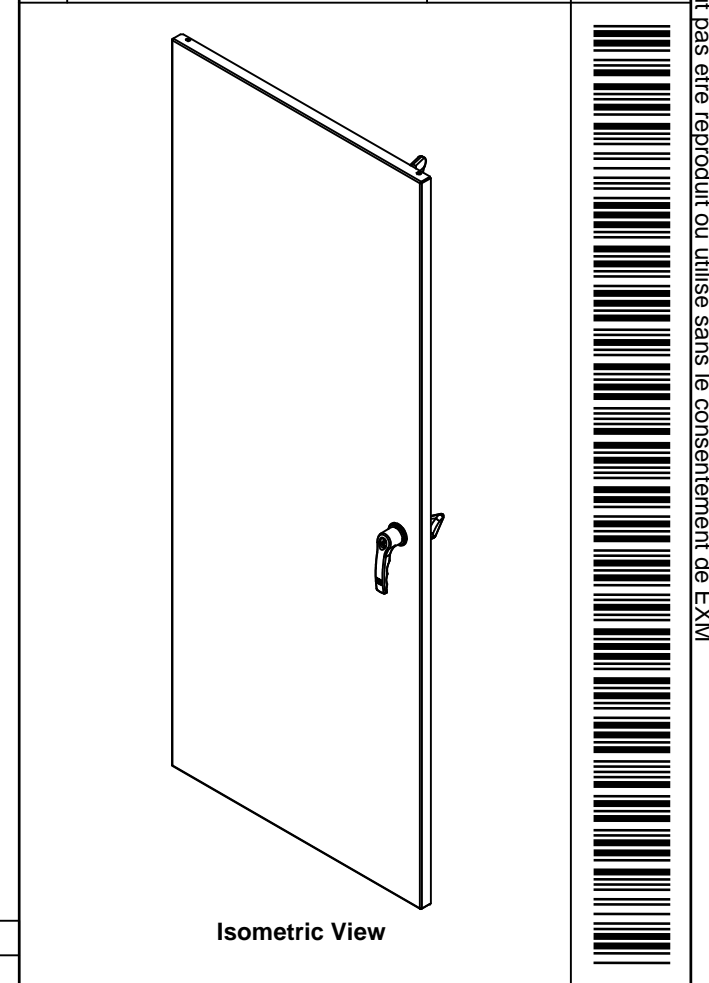

1	STK-P-02400S	0	Powder Paint (Asa-61 Grey / Smooth)
1	STK-S-00100	0.1.1	3.5" x 2" Silver Milar Flexcon Sticker
2	STK-Q-90042	0	5412 ES - Cabinet Closing Bar End (Small)
2	STK-Q-45655-60	0	5412 ES - Closing Bar
1	STK-K-50536	4	Handle Gear Clockwise Assy (Grip 32mm)
2	STK-Q-16405	2	Guide Stud - Small (No Paint Cap Required)
6	STK-Q-16060	0	Stud M6 x 18mm Aluminum
1	885 ESL2A	0	5412 ES Key Lock L-Handle (3 Pts)
1			
1			
4	STK-Q-33106	0	5412 ESSBU Buttable Hinge (Cover Part)
2	STK-Q-46020-60	3	5412 ES Vertical Door Stiffener 60"
1			
1			
1	5412EALBU602412G	0	5412EALBU 60" x 24" Cover Gasket
1	5412EALBU602412C-P	0	5412EALBU 60" x 24" Cover Part
6	STK-Q-07220	1	M6 Nylon Insert Lock Nut
Qty	Part Name	Rev	Description
Parts List			

Tél: (450) 979-4373 Fax: (450) 979-4626 www.exmweb.com		Flatness Aplatissement	
		Max 3.0mm	
Customer Client Drawn By / Dessiné Par: BoxCad: Annie		Projection	
Material / Matière: Aluminum 5052-H32 (1.7mm)		Date: 31/03/2015	
Color / Couleur: Asa-61 Grey		Finish / Fini: Smooth	
Description: 5412EALBU 60" x 24" Cover		Detail Rev.	
Part Number / Numéro Pièce: 5412EALBU602412C		Rev.:	3
		0	3

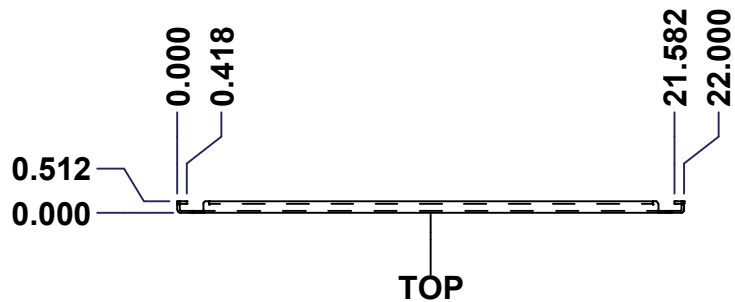

TOP

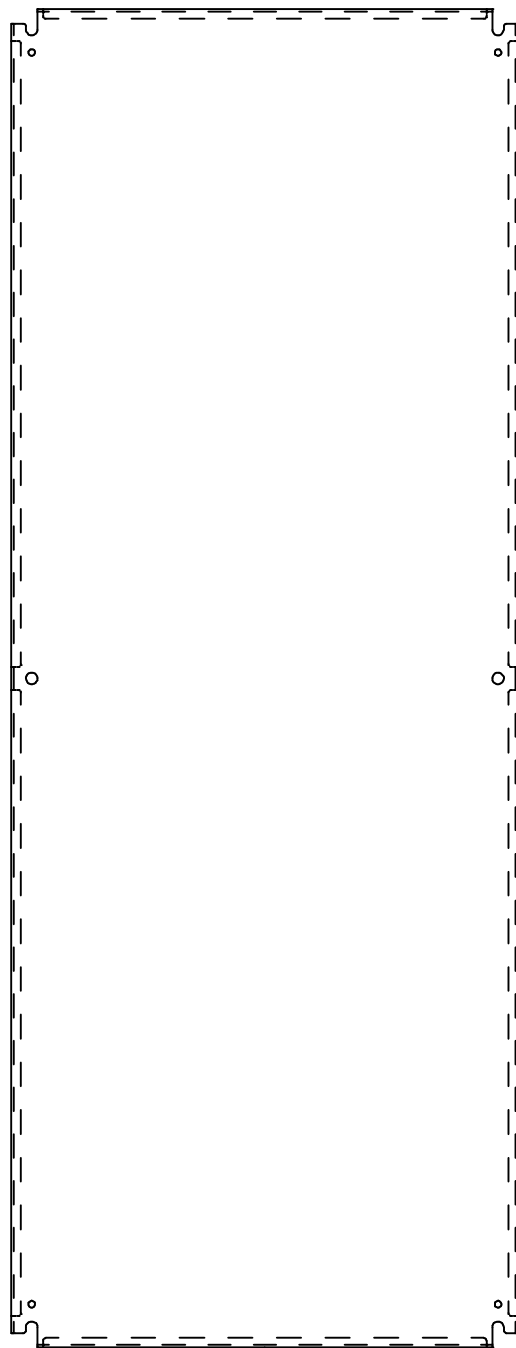

FRONT

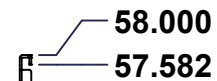

RIGHT

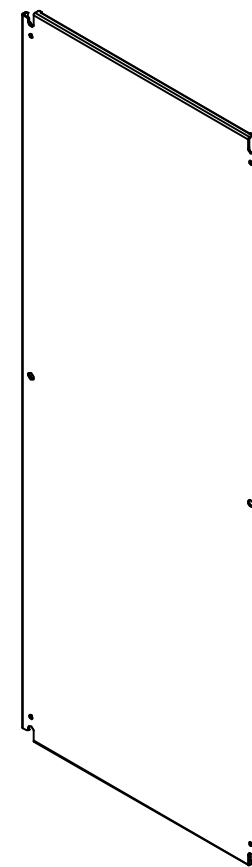
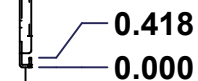

Isometric View



Ce dessin est confidentiel et ne doit pas être reproduit ou utilisé sans le consentement de EXM

No.	Revisions	Date	By/Par

		Flatness Aplatissement Max 3.0mm Projection 	
Tél: (450) 979-4373 Fax: (450) 979-4626 www.exmweb.com		Customer Client	
Drawn By Dessiné Par BoxCad		Date 1/23/2007	
Material Matière See Part List			
Color Couleur See Part List		Finish Fini See Part List	
Description 881 SP - Inner Panel			Detail Rev.
Part Number Numéro Pièce 881 SP6024			Rev. 1 0

Qty	Part Number	Rev	Description	Material	Color	Finish
1	STK-P-02401S	0	Powder Paint (White / Smooth)	Polyester-Epoxy Hybrid	White RAL9003	Smooth
1	881 SP6024-P	0	881 SP - Inner Panel Part	12 Ga H.R.P. & O.	White	Smooth

Parts List

This drawing is confidential and must not be reproduced or used without the consent of EXM

Ce dessin est confidentiel et ne doit pas être reproduit ou utilisé sans le consentement de EXM

Table 1			FRONT VIEW
CUT-OUT	XDIM	YDIM	DESCRIPTION
1	0.875	1.875	GROUND HOLE (RND Ø0.290)
2	21.125	1.875	GROUND HOLE (RND Ø0.290)
3	0.875	56.125	GROUND HOLE (RND Ø0.290)
4	21.125	56.125	GROUND HOLE (RND Ø0.290)
5	0.875	29.000	MTG STUD HOLE (RND Ø0.500)
6	21.125	29.000	MTG STUD HOLE (RND Ø0.500)

All knockouts are actual size / Les disques défonçables sont grandeur réel

No.	Revisions	Date	By/Par

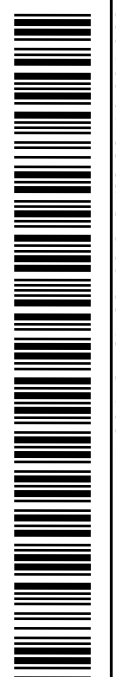
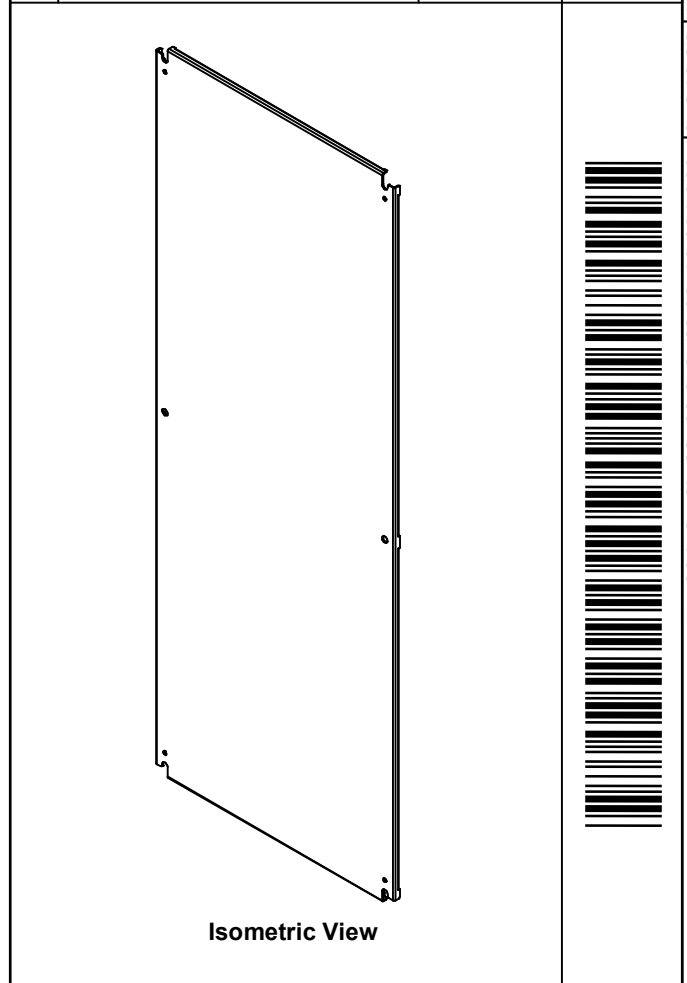
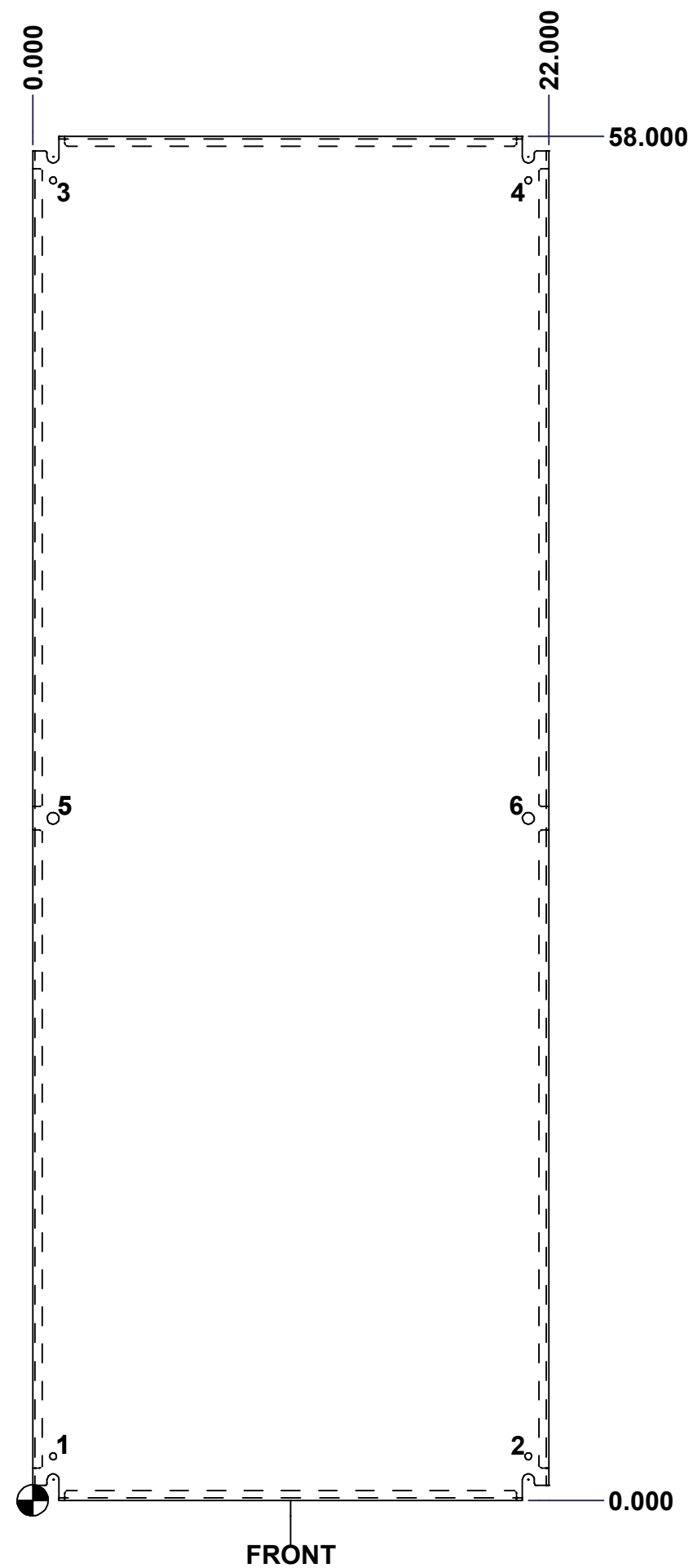

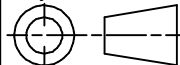
 Tél: (450) 979-4373 Fax: (450) 979-4626 www.exmweb.com		Flatness Aplatissement Max 3.0mm
Customer Client		Projection 
Drawn By Dessiné Par BoxCad		Date 1/23/2007
Material Matière See Part List		
Color Couleur See Part List	Finish Fini See Part List	
Description 881 SP - Inner Panel		Detail Rev.
Part Number Numéro Pièce 881 SP6024		Rev. 2 0