

This drawing is confidential and must not be reproduced or used without the consent of EXM

Ce dessin est confidentiel et ne doit pas être reproduit ou utilisé sans le consentement de EXM

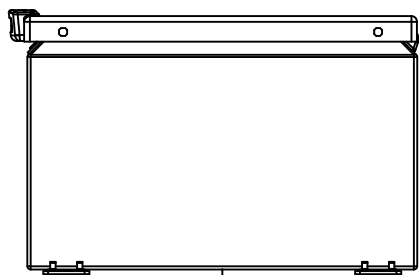

TOP

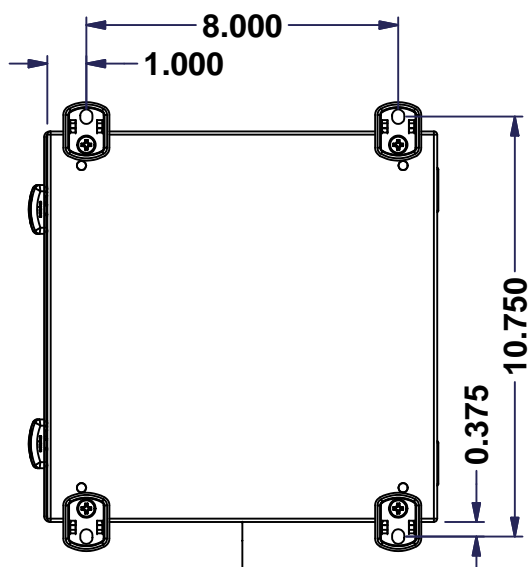

BACK

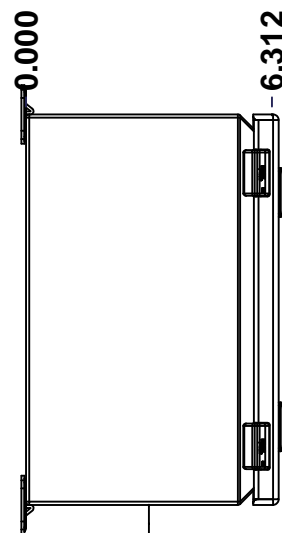

LEFT

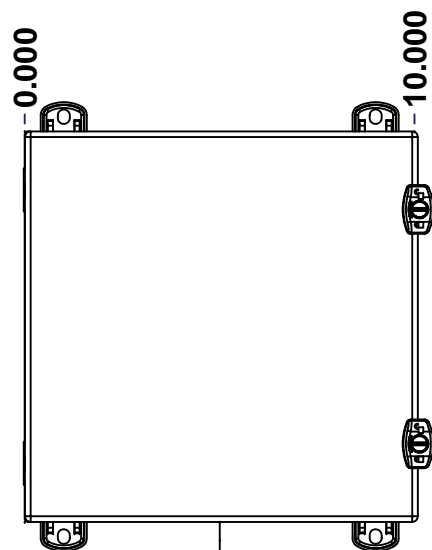

FRONT

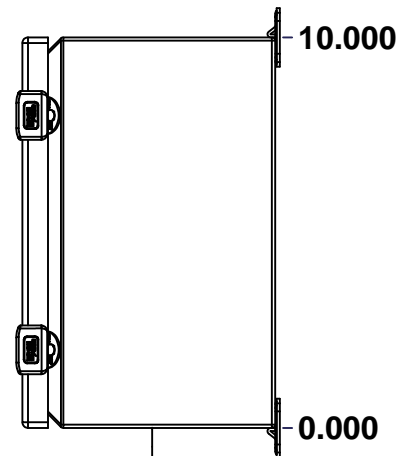

RIGHT

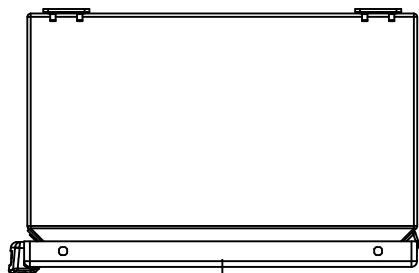

BOTTOM

No.	Revisions	Date	By/Par

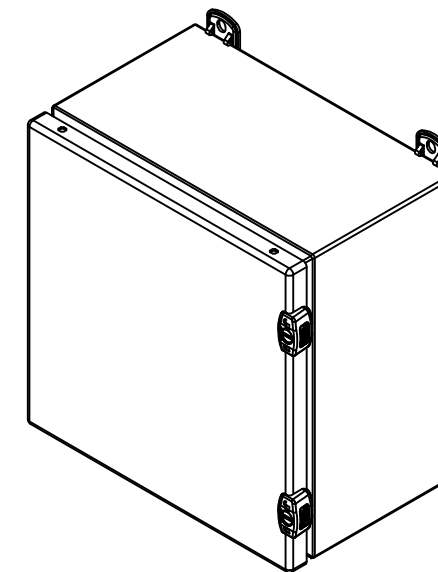

Isometric View



Tél: (450) 979-4373
 Fax: (450) 979-4626
www.exmweb.com

Flatness
Aplatissement

Max 3.0mm

Projection



Customer Client	Date
Drawn By / Dessiné Par: BoxCad: BoxCad	Date: 27-Sep-13
Material / Matière: Aluminum 5052-H32 (1.4mm)	
Color / Couleur: Asa-61 Grey	Finish / Fini: Smooth
Description: 5412EALCH 10" x 10" x 6" Assembly	Detail Rev.
Part Number / Numéro Pièce: 5412EALCH101006	Rev. 0

SEE BILL OF MATERIAL ON LAST PAGE

1
2

This drawing is confidential and must not be reproduced or used without the consent of EXM

Ce dessin est confidentiel et ne doit pas être reproduit ou utilisé sans le consentement de EXM

NOTE	
ITEM	DESCRIPTION
1	NEMA 4X Enclosure
2	C/W Standard ground standoffs on box and cover
3	W/O Standard door stiffener
4	C/W Standard inner panel (Included)
5	C/W Standard inner panel mounting standoffs
6	C/W 885 ESCHMF2 Mounting Feet (Installed)

No.	Revisions	Date	By/Par

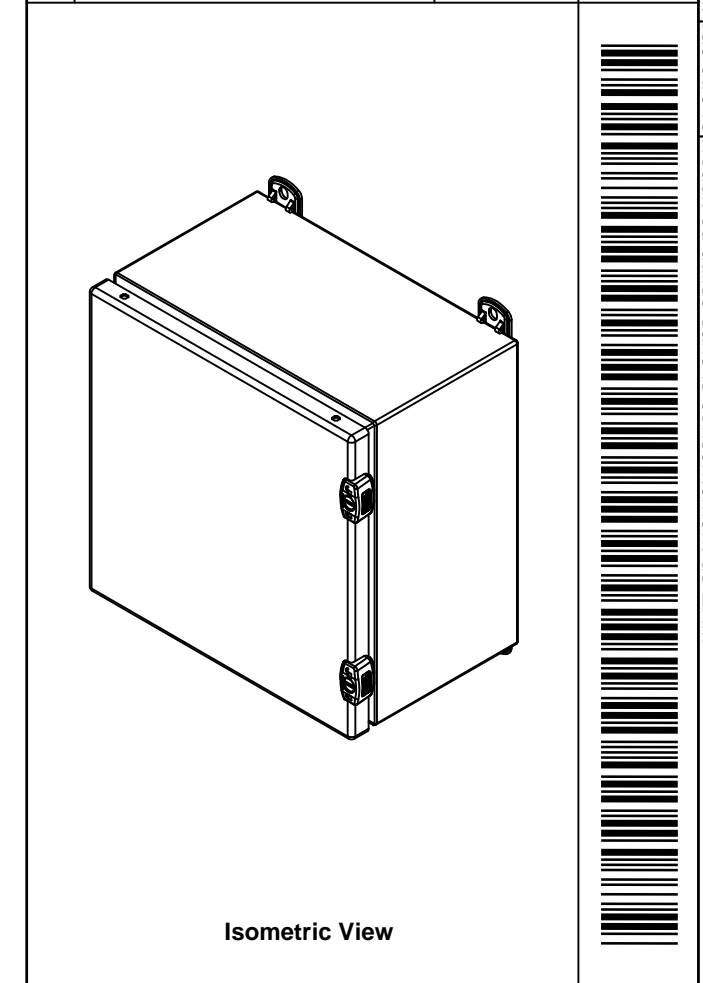

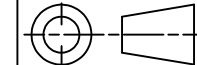
 Tél: (450) 979-4373 Fax: (450) 979-4626 www.exmweb.com		Flatness Aplatissement Max 3.0mm Projection 
Customer Client	Date	
Drawn By Dessiné Par	BoxCad: BoxCad	Date 27-Sep-13
Material Matière	Aluminum 5052-H32 (1.4mm)	
Color Couleur	Asa-61 Grey	Finish Fini Smooth
Description	Detail Rev.	
5412EALCH 10" x 10" x 6" Assembly		
Part Number Numéro Pièce	5412EALCH101006	Rev. 0

Qty	Part Number	Rev	Description
1	5412EALCH101006C	0	5412EALCH 10" x 10" Cover
1	885 ESSCHMFQ	0	5412 ESSCH Mounting Feet Accessory Kit
1	STK-K-02910	3	5412 ESCH Accessory Kit
8	STK-Q-07200	0	Flange Lock Nut
1	880 SP1010G	0	880 SP1010G - Inner Panel
1	5412EALCH101006B	0	5412EALCH 10" x 10" x 6" Body
2	STK-Q-08100	1	M5 Nylon Insert Lock Nut
Parts List			

PACKING		
ITEM	QTY	DESCRIPTION
STK-E-04313	1	CARTON 5412 ESCH101006
Plastic bag	1	To protect cover surface and inside gasket
Packaging label	1	White label with product number
STK-S-01100	1	ESCH EXM SQUARE STICKER

This drawing is confidential and must not be reproduced or used without the consent of EXM

Ce dessin est confidentiel et ne doit pas être reproduit ou utilisé sans le consentement de EXM

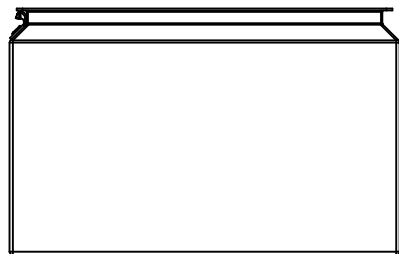

TOP

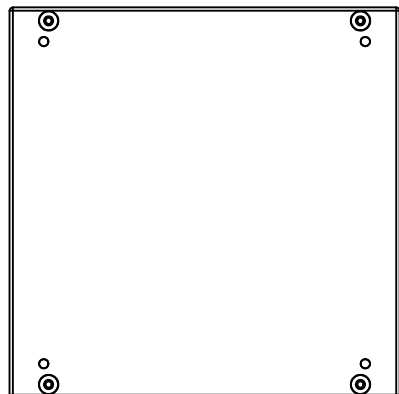

BACK

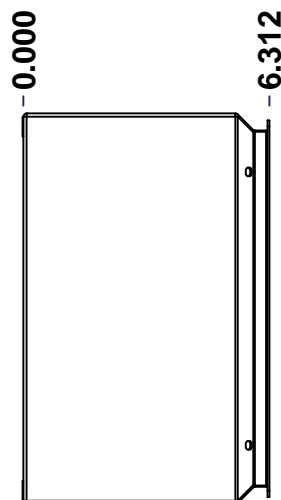

LEFT

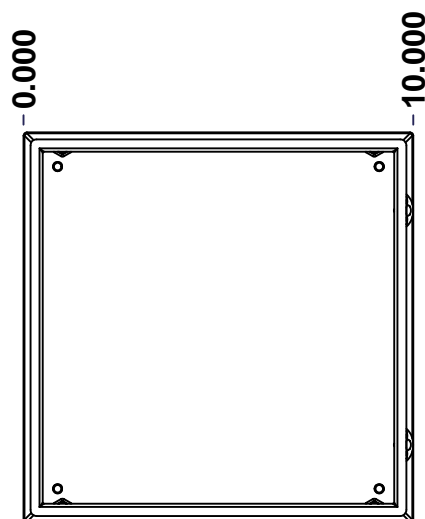

FRONT

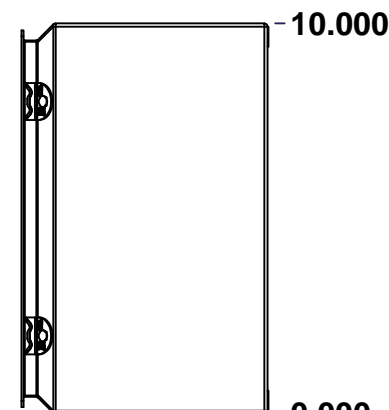

RIGHT

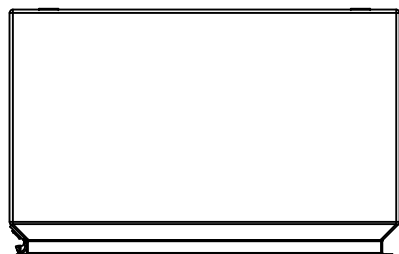

BOTTOM

No.	Revisions	Date	By/Par

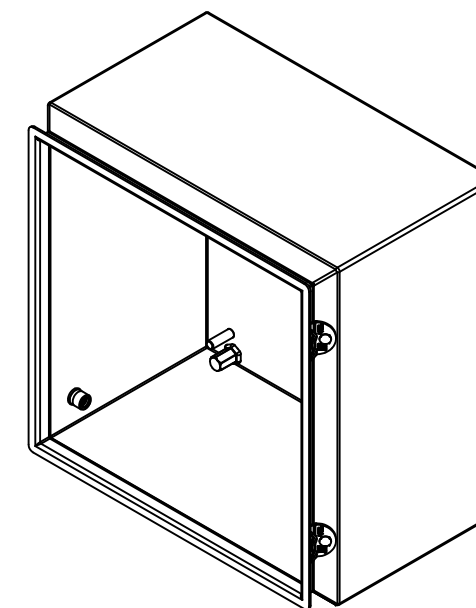

Isometric View



Tél: (450) 979-4373
 Fax: (450) 979-4626
www.exmweb.com

Flatness
Aplatissement

Max 3.0mm

Projection



Customer Client	Date
Drawn By Dessiné Par BoxCad: BoxCad	Date 27-Sep-13

Material
Matière Aluminum 5052-H32 (1.4mm)

Color Couleur Asa-61 Grey	Finish Fini Smooth
------------------------------	-----------------------

Description 5412EALCH 10" x 10" x 6" Body	Detail Rev.
--	-------------

Part Number Numéro Pièce	Rev.	1
5412EALCH101006B	0	7

SEE BILL OF MATERIAL ON LAST PAGE

This drawing is confidential and must not be reproduced or used without the consent of EXM

Ce dessin est confidentiel et ne doit pas être reproduit ou utilisé sans le consentement de EXM

STANDARD FEATURES ARE NOT LISTED IN THIS HOLE TABLE

HOLE TABLE - LEFT VIEW (CUSTOM FEATURE ONLY)

CUT-OUT	XDIM	YDIM	DESCRIPTION
1	4.625	0.875	STANDOFF M6 x 10mm (Inside)

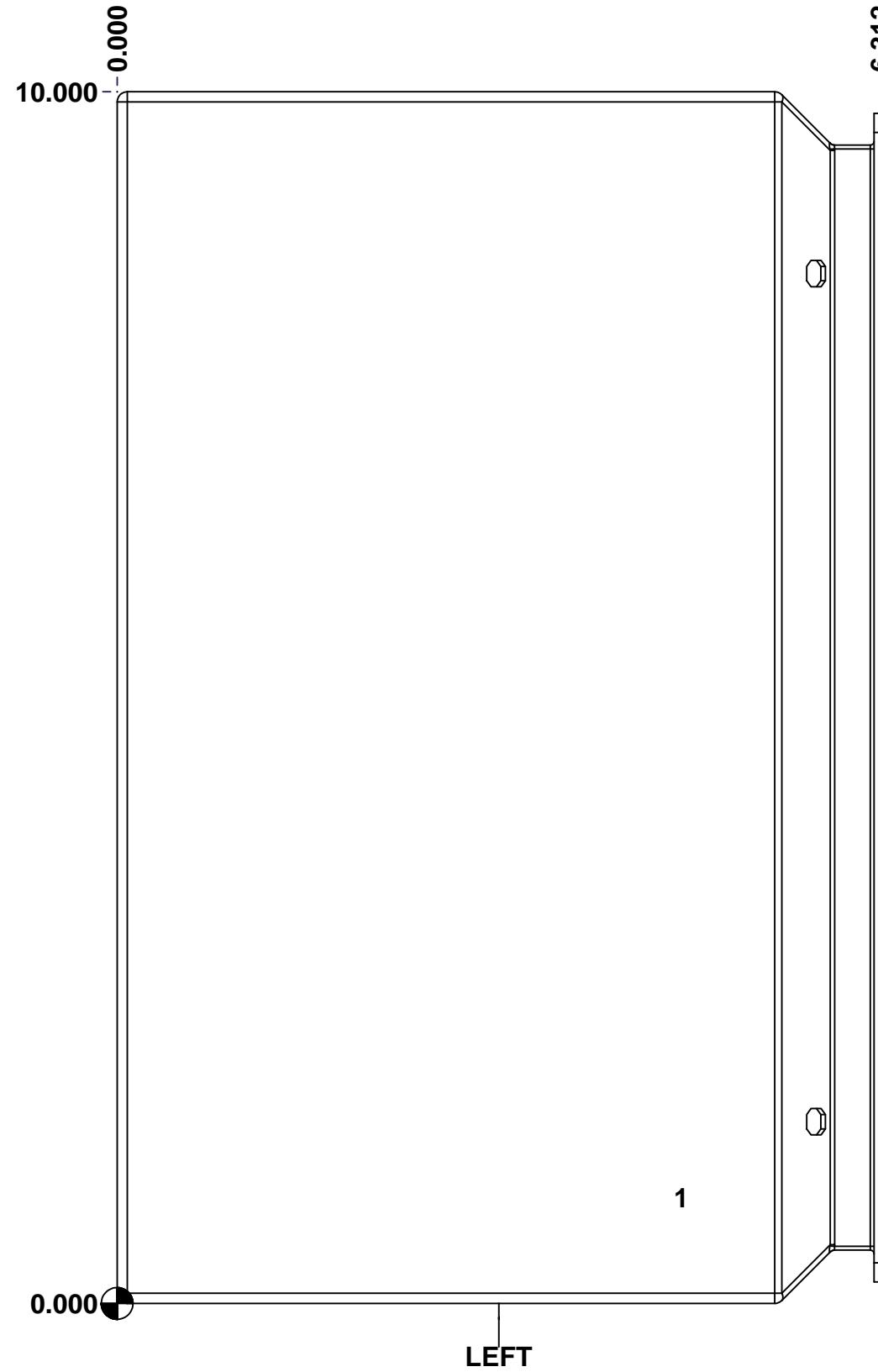

	Description		Status	
	5412EALCH 10" x 10" x 6" Body		(NULL)	
Part Number Numéro Pièce		Rev.	5	7
5412EALCH101006B		0		

This drawing is confidential and must not be reproduced or used without the consent of EXM

Ce dessin est confidentiel et ne doit pas être reproduit ou utilisé sans le consentement de EXM

STANDARD FEATURES ARE NOT LISTED IN THIS HOLE TABLE

HOLE TABLE - BACK VIEW (CUSTOM FEATURE ONLY)

CUT-OUT	XDIM	YDIM	DESCRIPTION
1	9.000	0.000	FOOT 885 ESCHMF2
2	1.000	0.000	FOOT 885 ESCHMF2
3	9.000	10.000	FOOT 885 ESCHMF2
4	1.000	10.000	FOOT 885 ESCHMF2
5	9.000	0.344	RIVET NUT M6_FH_CE (Inside)
6	1.000	0.344	RIVET NUT M6_FH_CE (Inside)
7	9.000	9.656	RIVET NUT M6_FH_CE (Inside)
8	1.000	9.656	RIVET NUT M6_FH_CE (Inside)
9	0.875	9.125	PEM FHS-M6-20 (Inside)
10	9.125	9.125	PEM FHS-M6-20 (Inside)
11	9.125	0.875	PEM FHS-M6-20 (Inside)
12	0.875	0.875	PEM FHS-M6-20 (Inside)

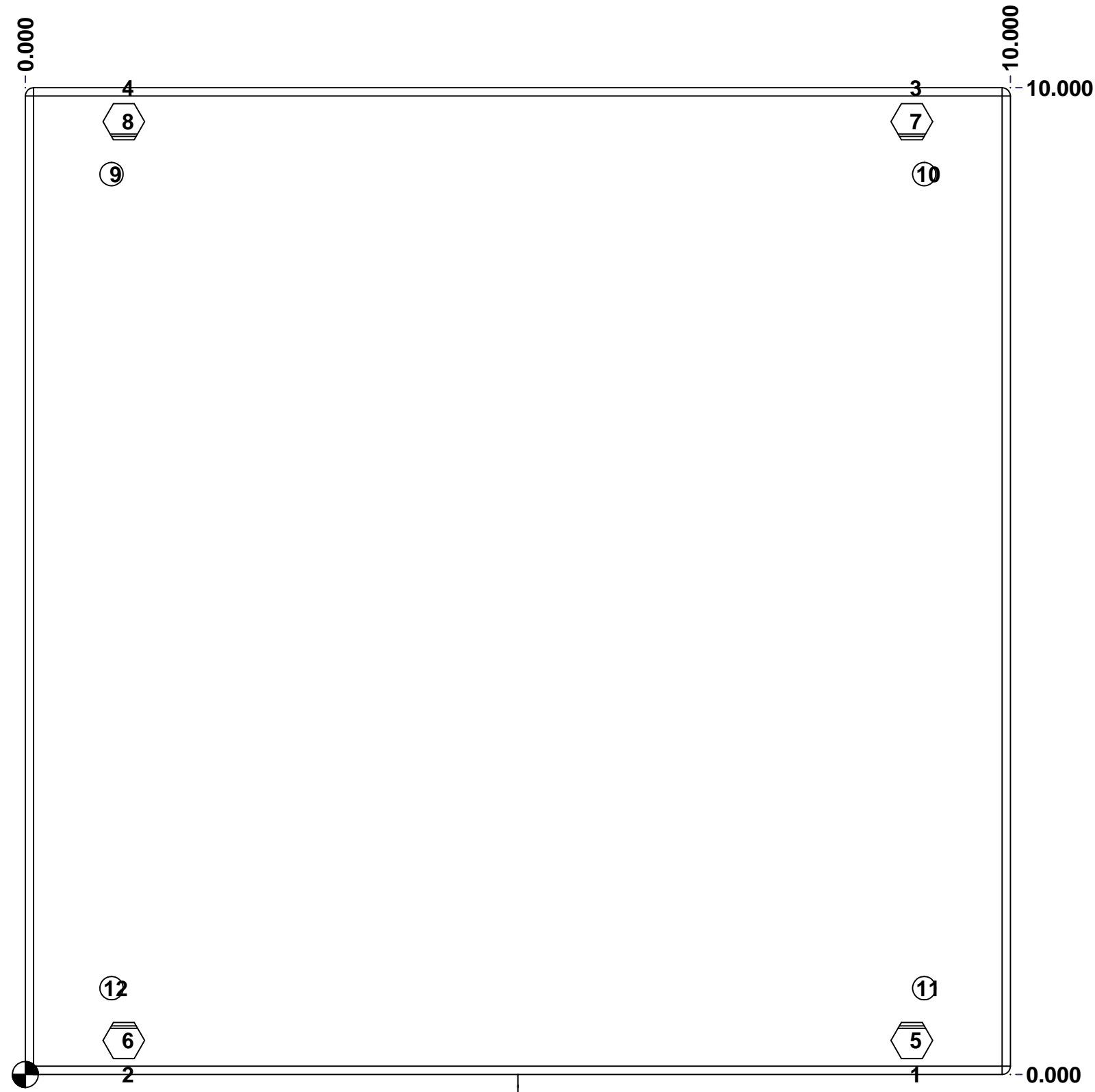

BACK

	Description	Status
	5412EALCH 10" x 10" x 6" Body	(NULL)
	Part Number Numéro Pièce	Rev.
	5412EALCH101006B	0 / 6 / 7

This drawing is confidential and must not be reproduced or used without the consent of EXM

Ce dessin est confidentiel et ne doit pas être reproduit ou utilisé sans le consentement de EXM

No.	Revisions	Date	By/Par

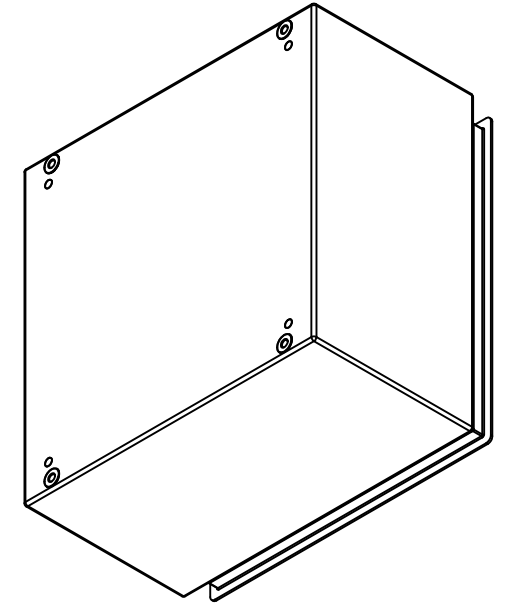

Isometric View



Qty	Part Number	Rev	Description
4	STK-PEM-FHS-M6-20	0	SS PEM Self-Clinching Stud M6 x 20.0mm
4	RIVET_NUT_SS_M6_FH_CE	0	Stainless Steel Rivet Nut M6 (Low Profile Close End)
1	STK-Q-08400	4	Aluminum Standoff M6 x 10mm
1	5412EALCH101006B-P	0	5412EALCH 10" x 10" x 6" Body Part
1	STK-P-02400S	0	Powder Paint (Asa-61 Grey / Smooth)
2	STK-A-70469	6	5412 ESSMCH - Stainless Steel 316 Body Catch Assembly
2	STK-Q-08100	1	M5 Nylon Insert Lock Nut
Parts List			

Tél: (450) 979-4373 Fax: (450) 979-4626 www.exmweb.com	Flatness Aplatissement	Max 3.0mm
	Projection	
Customer Client	Date	
Drawn By Dessiné Par	BoxCad: BoxCad	Date 27-Sep-13
Material Matière	Aluminum 5052-H32 (1.4mm)	
Color Couleur	Asa-61 Grey	Finish Fini Smooth
Description	5412EALCH 10" x 10" x 6" Body	
Part Number Numéro Pièce	Rev. 0	7
5412EALCH101006B		7

This drawing is confidential and must not be reproduced or used without the consent of EXM

Ce dessin est confidentiel et ne doit pas être reproduit ou utilisé sans le consentement de EXM

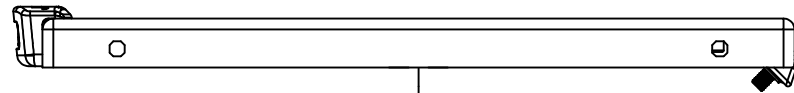

TOP

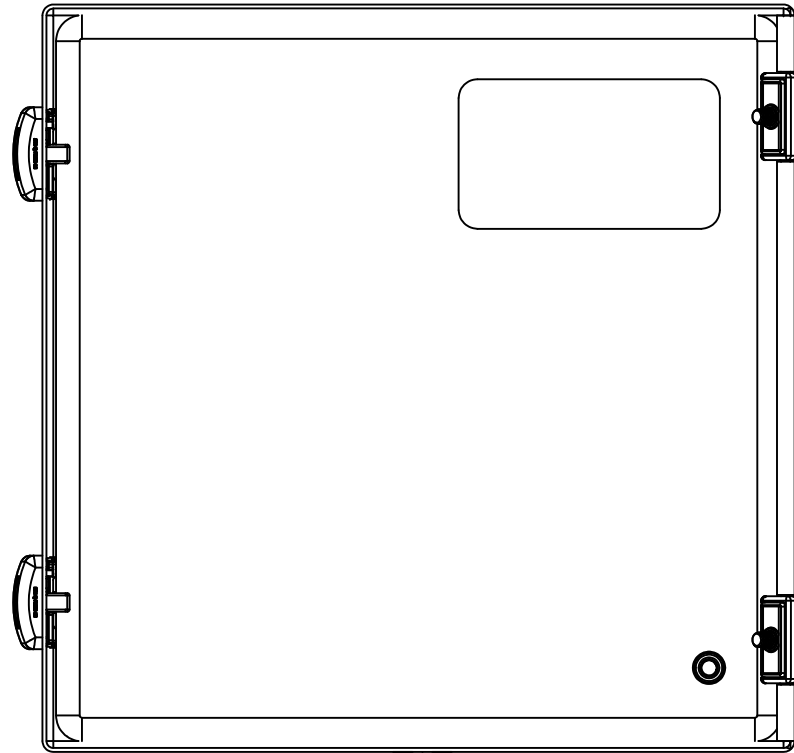

BACK

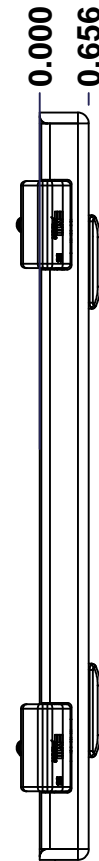

LEFT

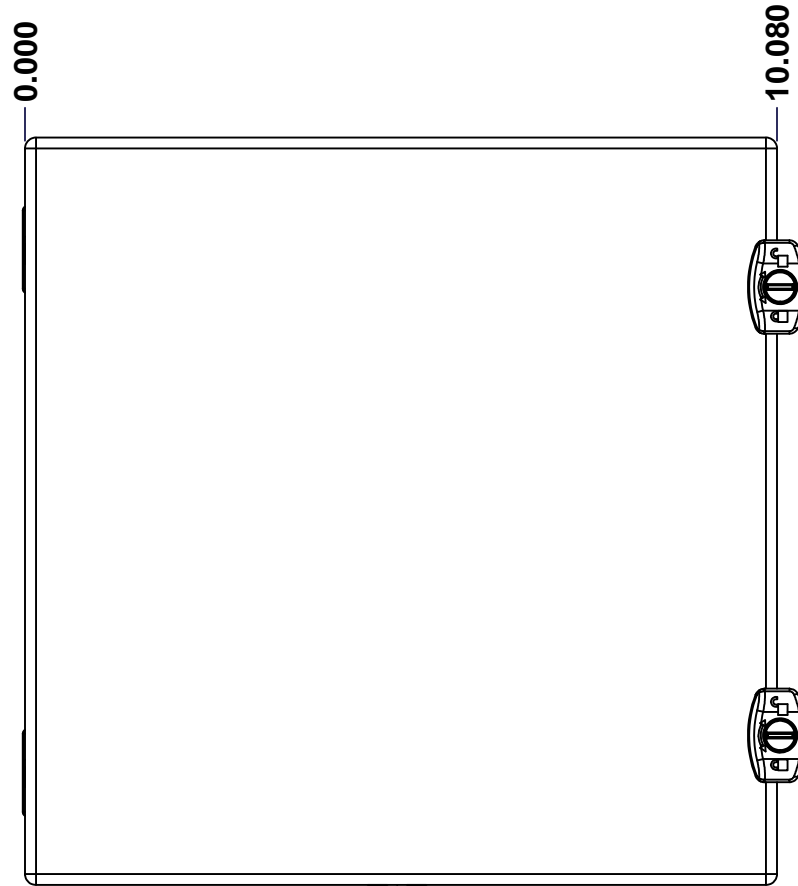

FRONT

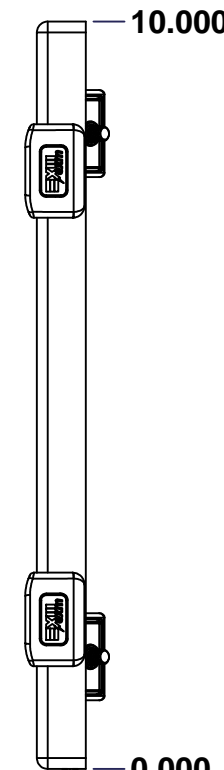

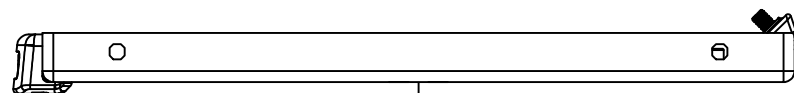

RIGHT

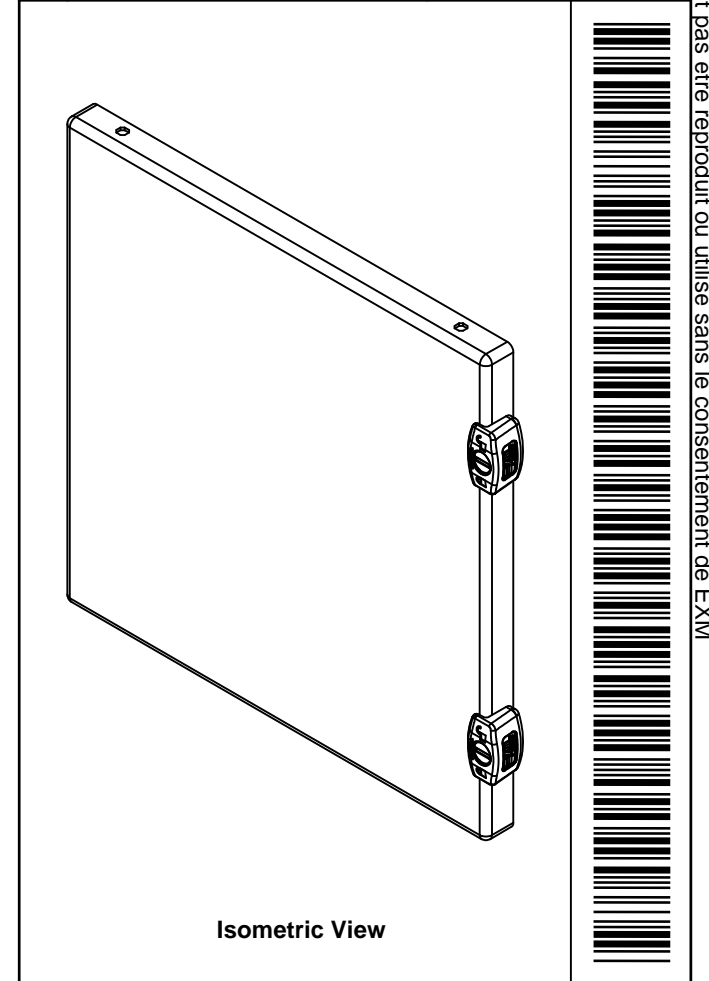

BOTTOM

No.	Revisions	Date	By/Par

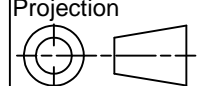

 Tél: (450) 979-4373 Fax: (450) 979-4626 www.exmweb.com		Flatness Aplatissement Max 3.0mm Projection 
Customer Client	Date	Date
Drawn By Dessiné Par	BoxCad: BoxCad	Date 27-Sep-13
Material Matière	Aluminum 5052-H32 (1.4mm)	
Color Couleur	Asa-61 Grey	Finish Fini Smooth
Description	Detail Rev.	
5412EALCH 10" x 10" Cover		
Part Number Numéro Pièce	Rev.	1 3
5412EALCH101006C	0	

SEE BILL OF MATERIAL ON LAST PAGE

This drawing is confidential and must not be reproduced or used without the consent of EXM

Ce dessin est confidentiel et ne doit pas être reproduit ou utilisé sans le consentement de EXM

STANDARD FEATURES ARE NOT LISTED IN THIS HOLE TABLE			
HOLE TABLE - FRONT VIEW (CUSTOM FEATURE ONLY)			
CUT-OUT	XDIM	YDIM	DESCRIPTION
1	10.080	2.000	LOCK 880 SCQ2MS @ 0.0°
2	2.750	8.000	LABEL_EXM
3	10.080	8.000	LOCK 880 SCQ2MS @ 0.0°
4	1.145	1.125	STANDOFF M6 x 10mm (Inside)

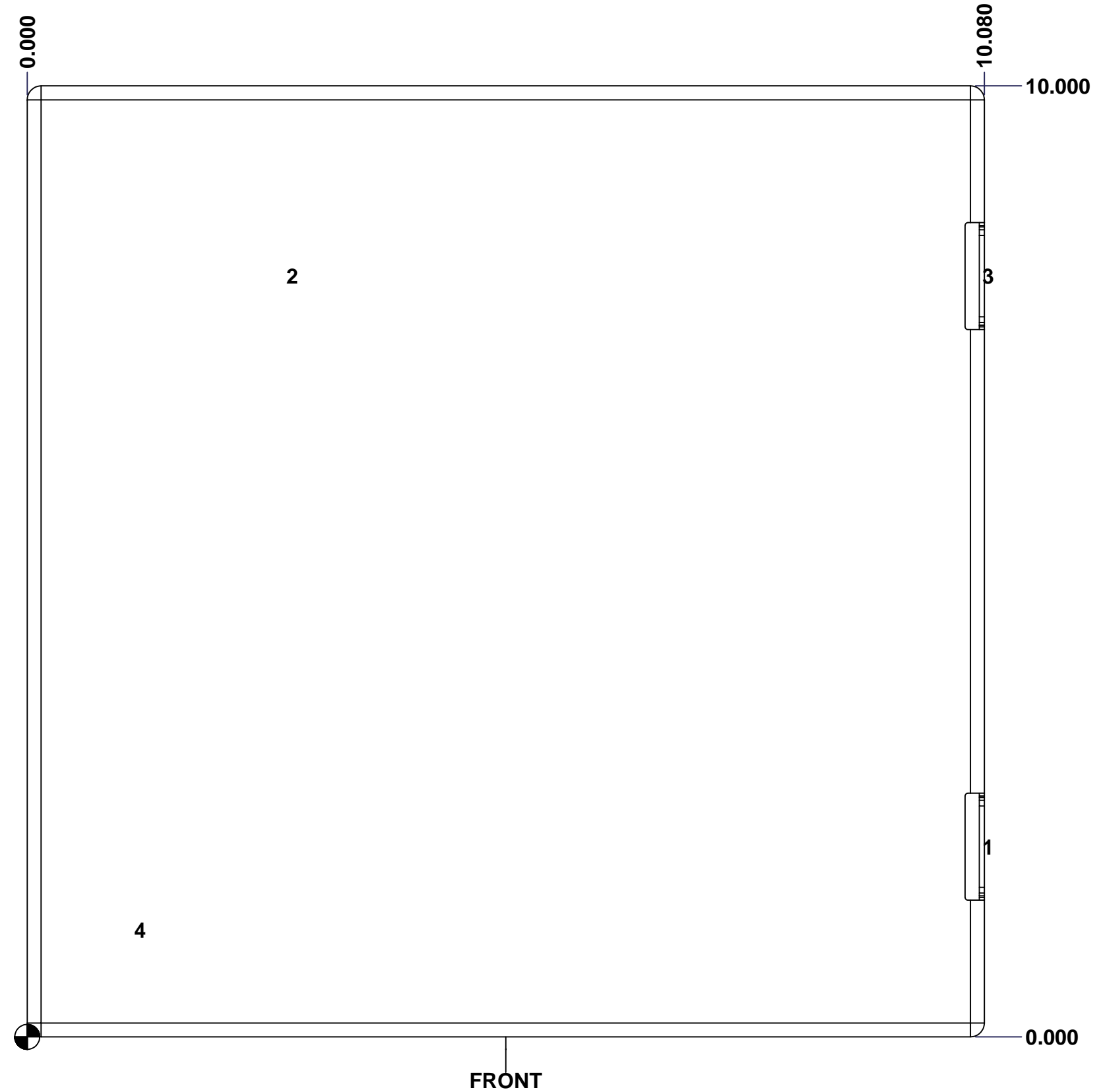

FRONT

	Description	Status	
	5412EALCH 10" x 10" Cover	(NULL)	
	Part Number Numéro Pièce	Rev.	
	5412EALCH101006C	0	2 3

This drawing is confidential and must not be reproduced or used without the consent of EXM

Ce dessin est confidentiel et ne doit pas être reproduit ou utilisé sans le consentement de EXM

No.	Revisions	Date	By/Par

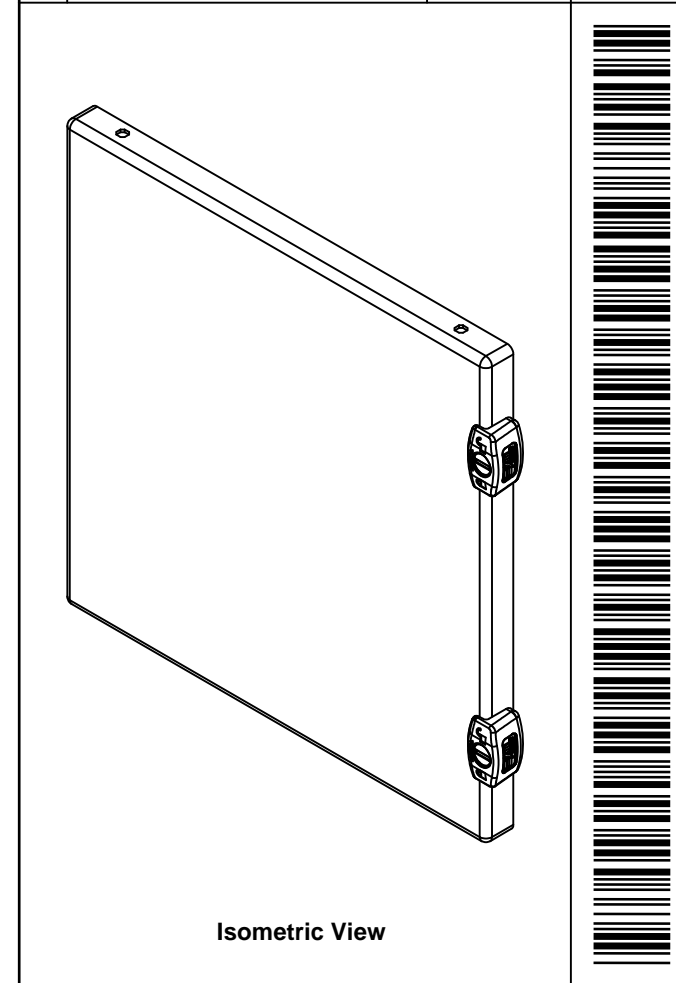

Isometric View

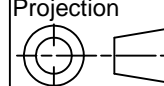
 Tél: (450) 979-4373 Fax: (450) 979-4626 www.exmweb.com		Flatness Aplatissement Max 3.0mm Projection 
Customer Client	Date	
Drawn By Dessiné Par	BoxCad: BoxCad	Date 27-Sep-13
Material Matière	Aluminum 5052-H32 (1.4mm)	
Color Couleur	Asa-61 Grey	Finish Fini Smooth
Description	Detail Rev.	
5412EALCH 10" x 10" Cover		
Part Number Numéro Pièce	Rev. 3	3
5412EALCH101006C	0	3

Qty	Part Number	Rev	Description
1	STK-Q-08400	4	Aluminum Standoff M6 x 10mm
1	5412EALCH101006G	0	5412EALCH 10" x 10" Gasket
1	STK-S-00100	0	3.5" x 2" Silver Milar Flexcon Sticker
1	STK-P-02400S	0	Powder Paint (Asa-61 Grey / Smooth)
1	5412EALCH101006C-P	0	5412EALCH 10" x 10" Cover Part
2	STK-A-33038	3	5412 ESSMCH - Stainless Steel Hinge
2	880SCQ2S	3	5412 ESMCH - External Lock Assy - Slot Lock
Parts List			

This drawing is confidential and must not be reproduced or used without the consent of EXM

Ce dessin est confidentiel et ne doit pas être reproduit ou utilisé sans le consentement de EXM

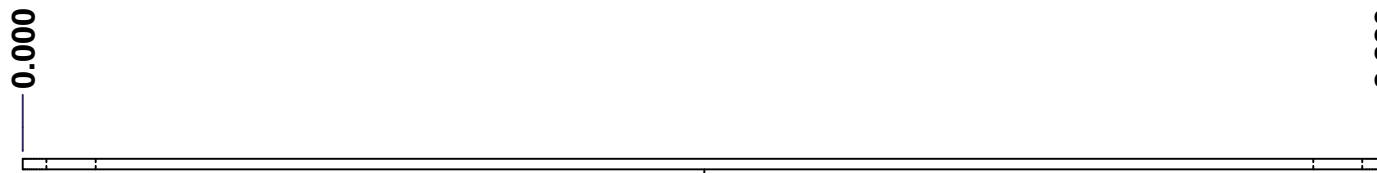

TOP

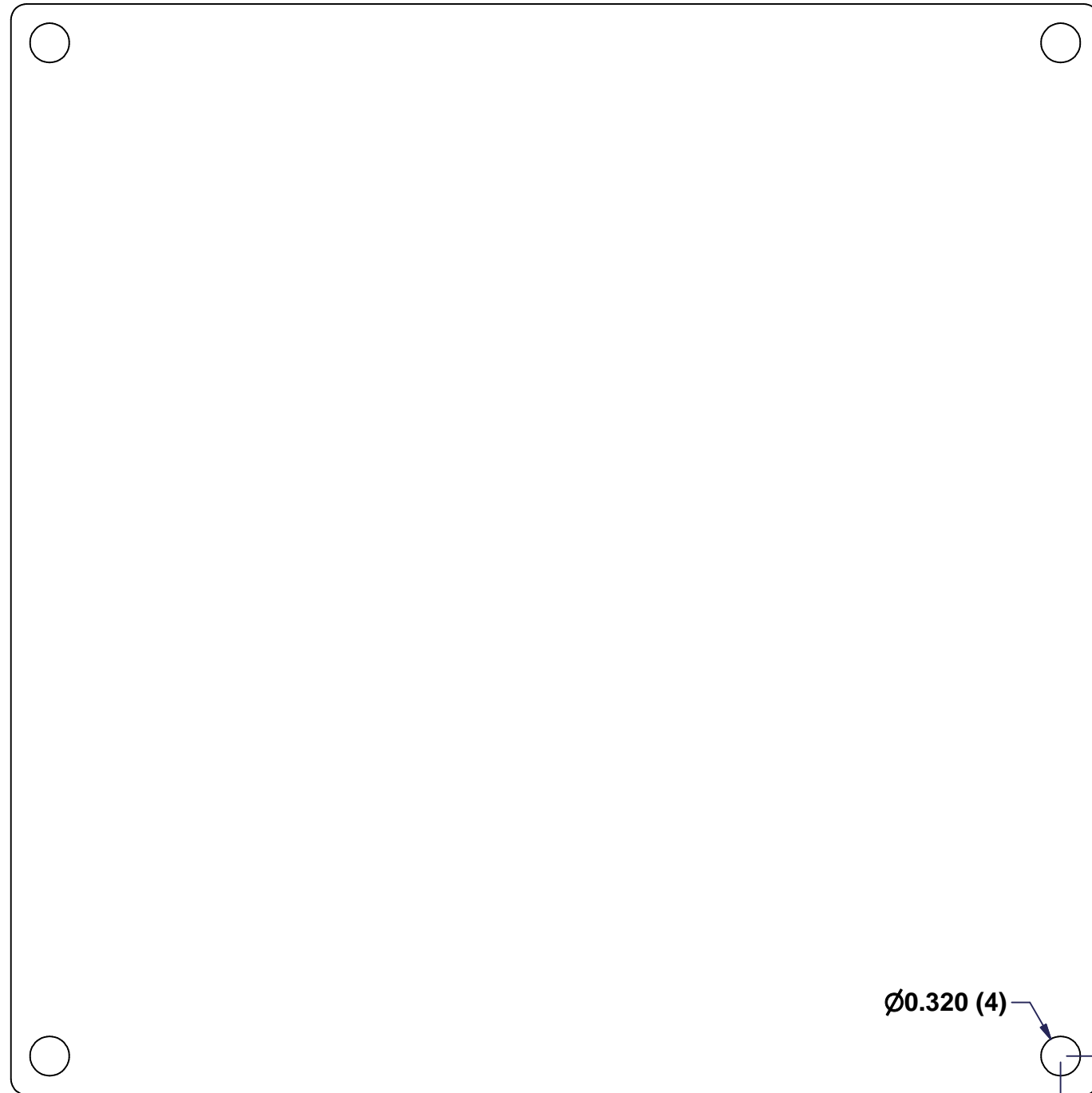

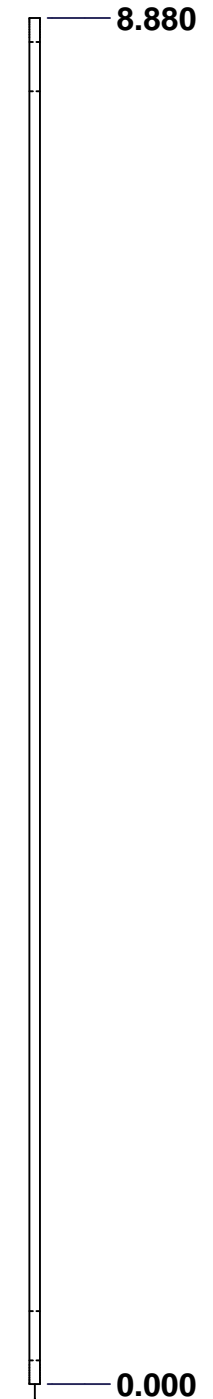

FRONT

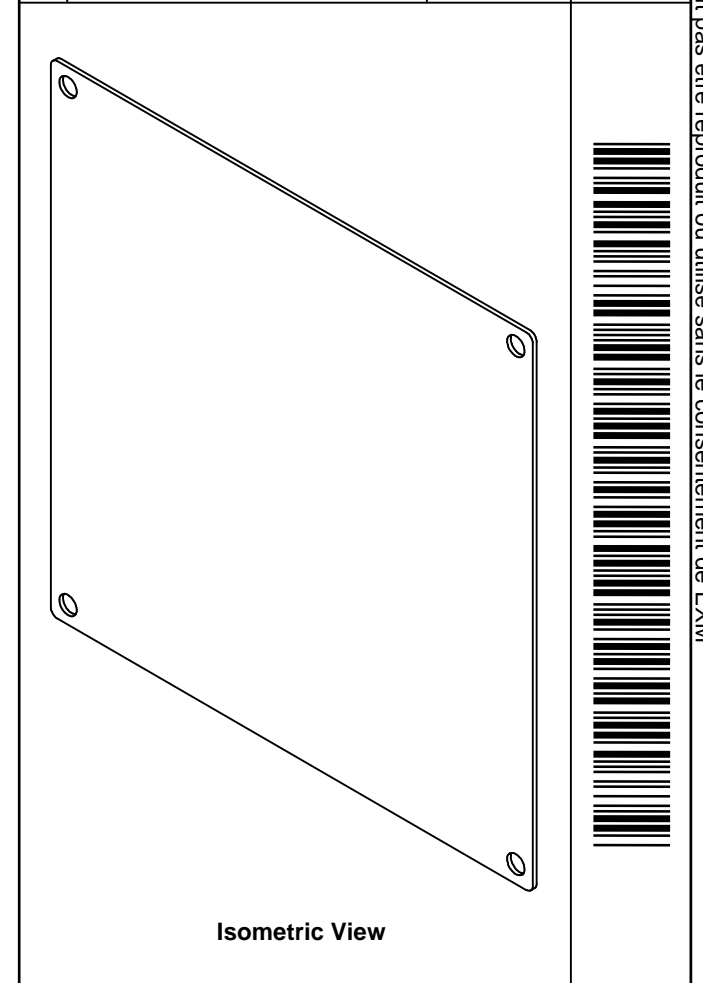

RIGHT

No.	Revisions	Date	By/Par

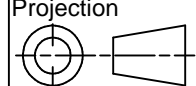

 Tél: (450) 979-4373 Fax: (450) 979-4626 www.exmweb.com	Flatness Aplatissement Max 3.0mm	
	Projection 	
Customer Client	Date	
Drawn By Dessiné Par BoxCad	Date 23-Jan-07	
Material Matière	14 Ga Galvanized (1.7mm)	
Color Couleur Unpainted	Finish Fini Galvanized	
Description 880 SP1010G - Inner Panel		Detail Rev.
Part Number Numéro Pièce	Rev. 0	1 2

SEE BILL OF MATERIAL ON LAST PAGE

880 SP1010G

This drawing is confidential and must not be reproduced or used without the consent of EXM

Ce dessin est confidentiel et ne doit pas être reproduit ou utilisé sans le consentement de EXM

No.	Revisions	Date	By/Par

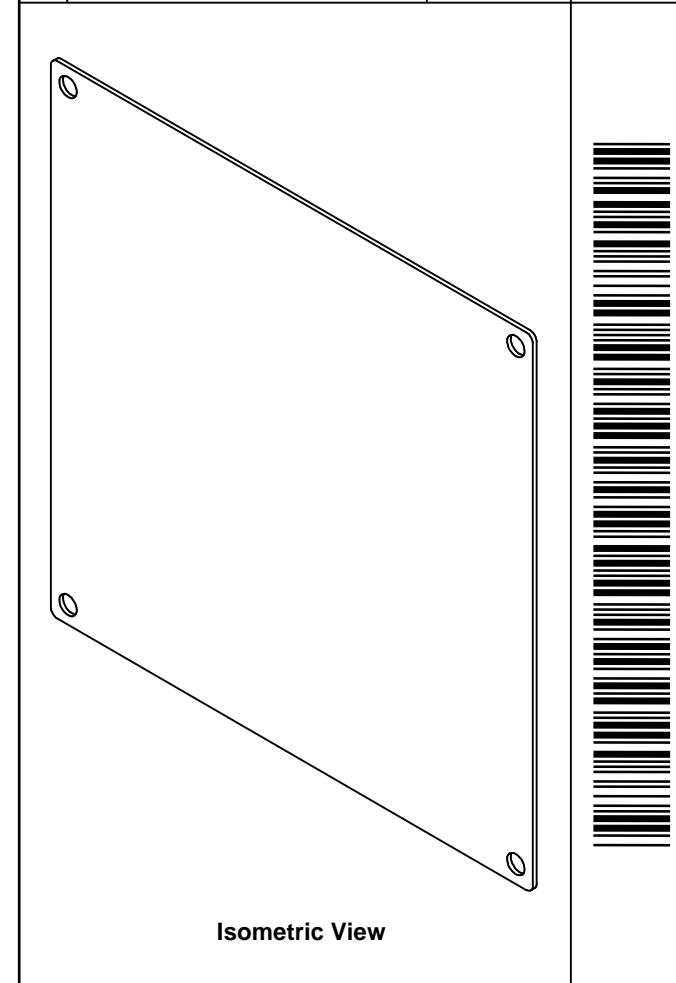

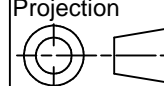
 Tél: (450) 979-4373 Fax: (450) 979-4626 www.exmweb.com		Flatness Aplatissement Max 3.0mm	
		Projection 	
Customer Client		Date	
Drawn By Dessiné Par BoxCad		Date 23-Jan-07	
Material Matière 14 Ga Galvanized (1.7mm)			
Color Couleur Unpainted		Finish Fini Galvanized	
Description 880 SP1010G - Inner Panel			Detail Rev.
Part Number Numéro Pièce 880 SP1010G		Rev. 0	2 / 2

Qty	Part Number	Rev	Description
1	880 SP1010G-P	0	880 SP1010G - Inner Panel Part
Parts List			