

This drawing is confidential and must not be reproduced or used without the consent of EXM

Ce dessin est confidentiel et ne doit pas être reproduit ou utilisé sans le consentement de EXM

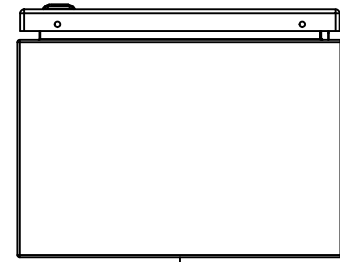

TOP

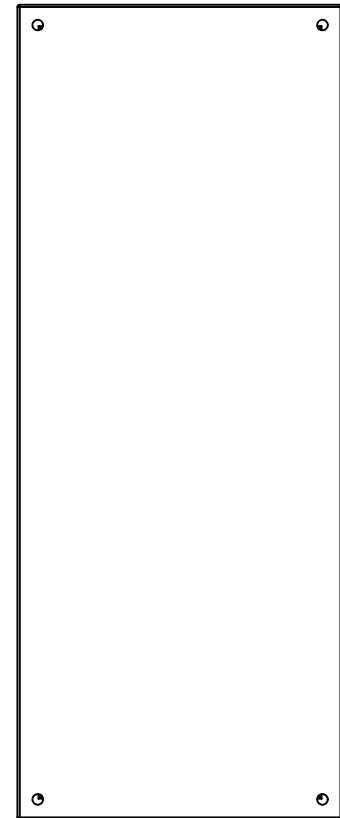

BACK

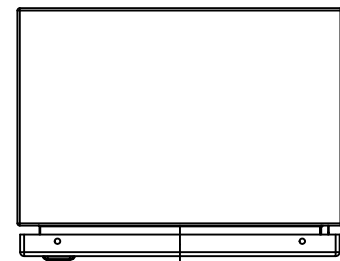

BOTTOM

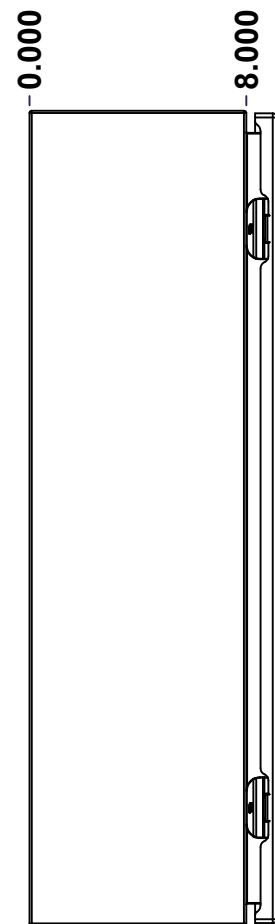

LEFT

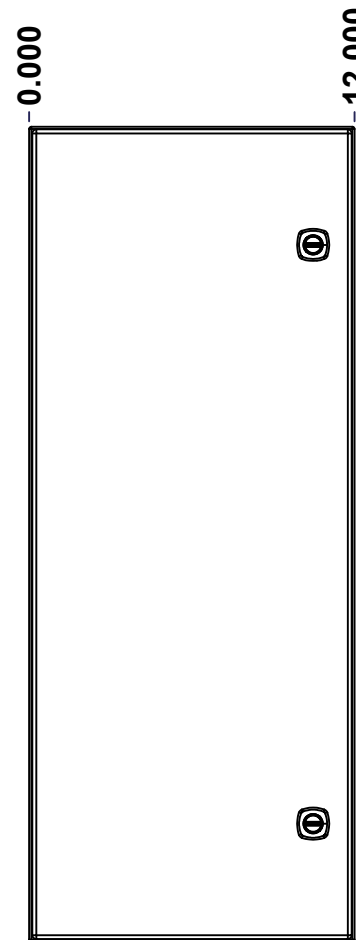

FRONT

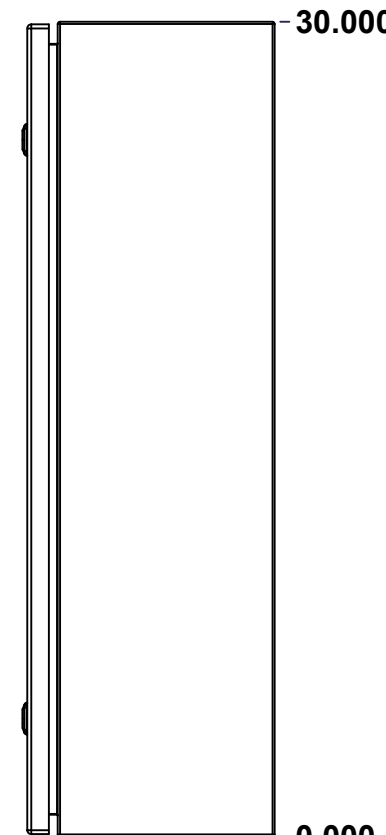

RIGHT

| No. | Revisions | Date | By/Par |
|-----|-----------|------|--------|
|     |           |      |        |
|     |           |      |        |
|     |           |      |        |
|     |           |      |        |
|     |           |      |        |

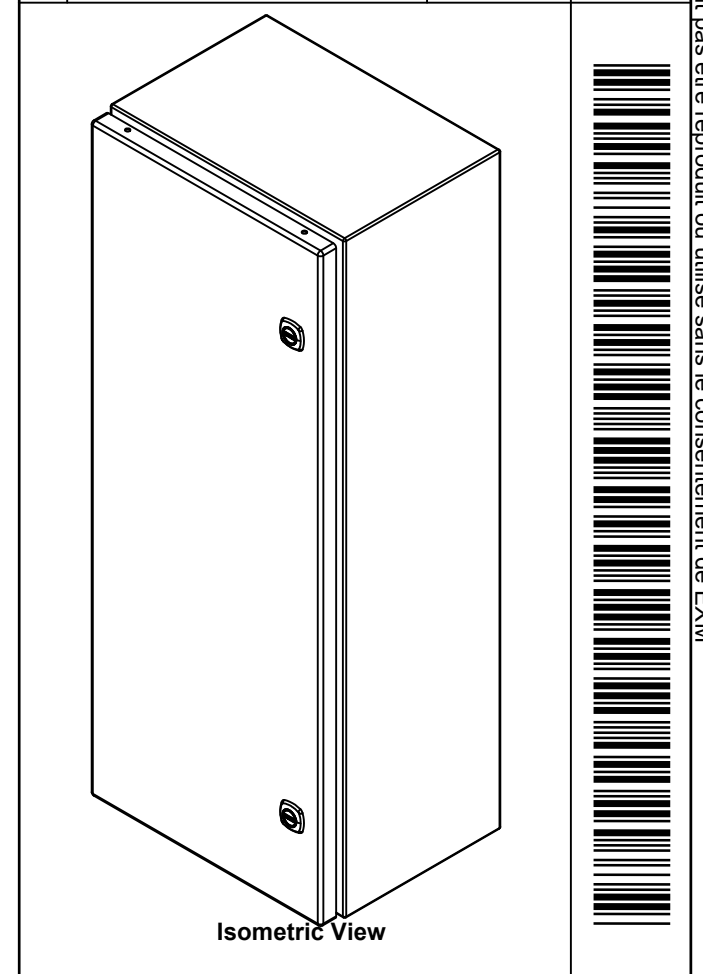

Isometric View

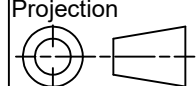
|  |                           |   |
|--|---------------------------|---|
|  Tél: (450) 979-4373<br>Fax: (450) 979-4626<br><a href="http://www.exmweb.com">www.exmweb.com</a> |                           | Flatness<br>Aplatissement<br>Max 3.0mm<br>Projection<br> |
| Customer<br>Client   | Date                      |   |
| Drawn By<br>Dessiné Par  | BoxCad: BoxCad            | Date 15-Jan-13  |
| Material<br>Matière  | 16 Ga H.R.P. & O. (1.4mm) |   |
| Color<br>Couleur   | Asa-61 Grey               | Finish<br>Fini Smooth   |
| Description  | Detail Rev.               |   |
| 5412ESBU 30" x 12" x 8" Assembly   |                           |   |
| Part Number<br>Numéro Pièce  | Rev. 0                    | 1<br>2  |
| <b>5412ESBU301208</b>  |                           |   |

SEE BILL OF MATERIAL ON LAST PAGE

This drawing is confidential and must not be reproduced or used without the consent of EXM

Ce dessin est confidentiel et ne doit pas être reproduit ou utilisé sans le consentement de EXM

| NOTE |  |
|------|--|
| ITEM | DESCRIPTION                                |
| 1    | NEMA 4/12 Enclosure                        |
| 2    | C/W Standard ground studs on box and cover |
| 3    | C/W Standard door stiffener                |
| 4    | C/W Standard inner panel (Included)        |
| 5    | C/W Standard inner panel mounting studs    |

| No. | Revisions | Date | By/Par |
|-----|-----------|------|--------|
|     |           |      |        |
|     |           |      |        |
|     |           |      |        |
|     |           |      |        |
|     |           |      |        |
|     |           |      |        |

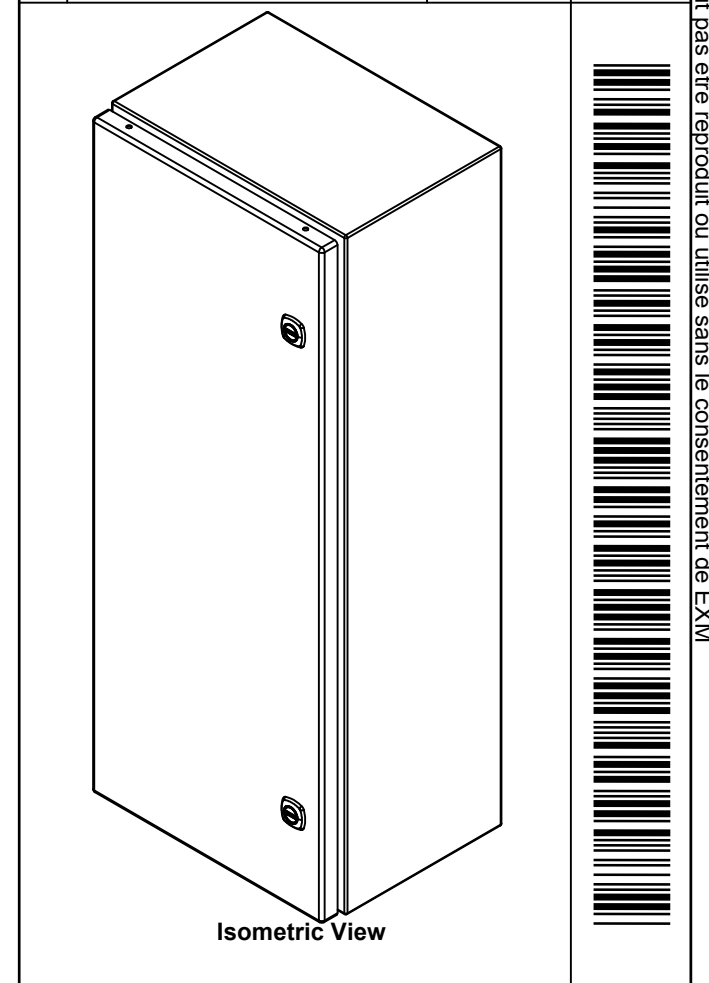

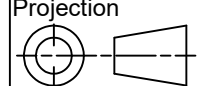
|  |                                  |   |
|--|----------------------------------|---|
|  Tél: (450) 979-4373<br>Fax: (450) 979-4626<br><a href="http://www.exmweb.com">www.exmweb.com</a> |                                  | Flatness<br>Aplatissement<br>Max 3.0mm<br>Projection<br> |
| Customer<br>Client   | Date                             |   |
| Drawn By<br>Dessiné Par  | BoxCad: BoxCad                   | Date 15-Jan-13  |
| Material<br>Matière  | 16 Ga H.R.P. & O. (1.4mm)        |   |
| Color<br>Couleur   | Asa-61 Grey                      | Finish<br>Fini Smooth   |
| Description  | 5412ESBU 30" x 12" x 8" Assembly |   |
| Part Number<br>Numéro Pièce  | <b>5412ESBU301208</b>            | Rev. 2<br><b>0</b>  |

| PACKING               |     |  |
|-----------------------|-----|--|
| ITEM                  | QTY | DESCRIPTION                                |
| Cardboard sleeve      | 2   | Top and Bottom                             |
| Cardboard strip       | 2   | Between back of enclosure and inner panel  |
| Plastic bag           | 1   | To protect cover surface and inside gasket |
| Plastic strap - Black | 2   | To Squeeze the 2 cardboard sleeve together |
| Packaging label       | 1   | White label with product number            |

| Qty        | Part Number     | Rev | Description  |
|------------|-----------------|-----|--|
| 1          | STK-K-01800     | 5   | 5412 ES Accessory Kit                                  |
| 1          | 881 SP3012G     | 0   | 881 SP - Inner Panel                                   |
| 1          | 5412ESBU301208C | 0   | 5412ESBU 30" x 12" Cover                               |
| 4          | STK-Q-07310     | 2   | Flange Lock Nut M8                                     |
| 4          | STK-Q-07610     | 8   | M8 Plastic Spacer 22.2mm                               |
| 1          | 5412ESBU301208B | 0   | 5412ESBU 30" x 12" x 8" Body                           |
| 4          | STK-Q-04050-07  | 7   | M6 x 7mm Hexagon Socket Head Machine Screw with Nyseal |
| Parts List |                 |     |  |

This drawing is confidential and must not be reproduced or used without the consent of EXM

Ce dessin est confidentiel et ne doit pas être reproduit ou utilisé sans le consentement de EXM

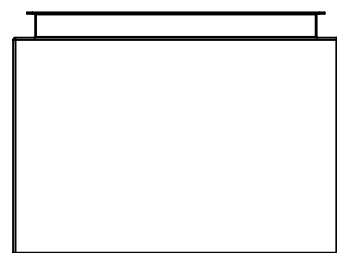

TOP

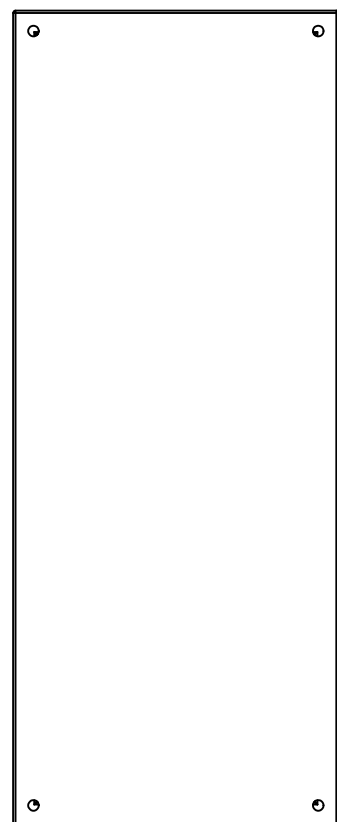

BACK

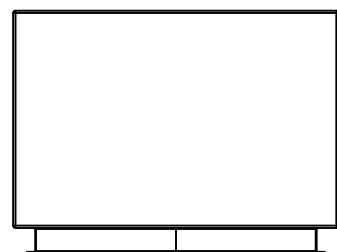

BOTTOM

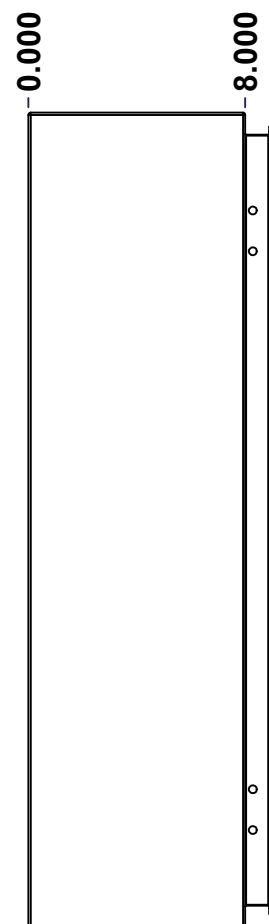

LEFT

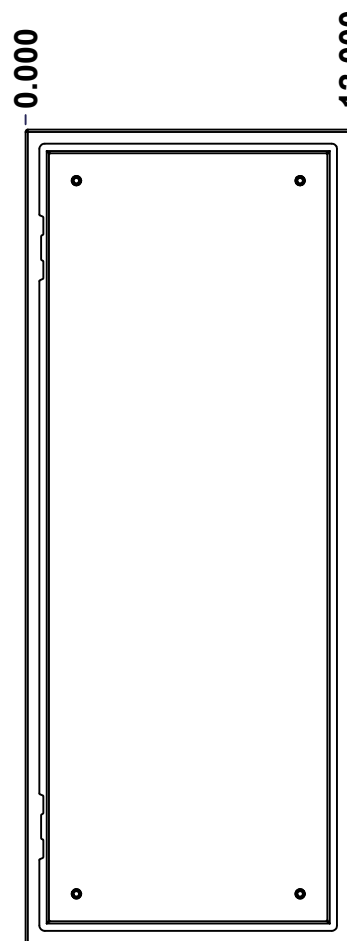

FRONT

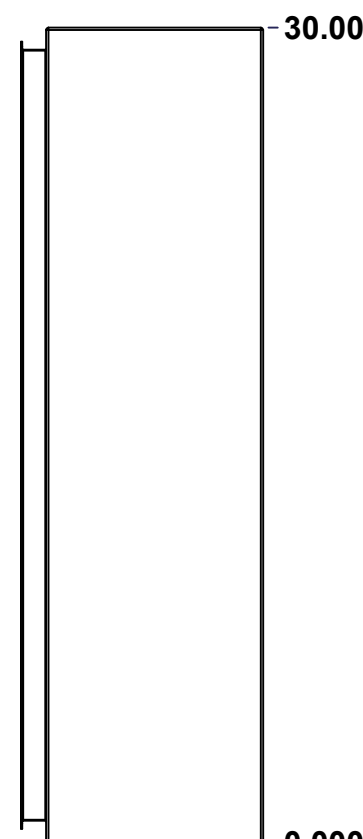

RIGHT

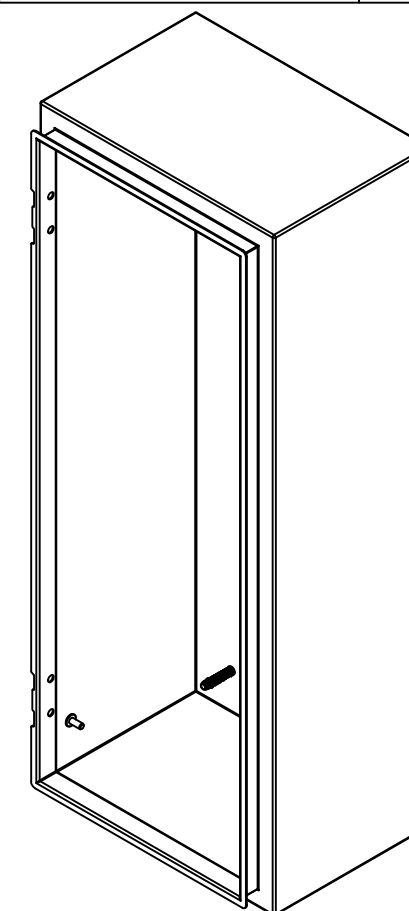

Isometric View

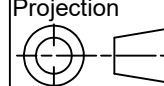

| No. | Revisions | Date | By/Par |
|-----|-----------|------|--------|
|     |           |      |        |
|     |           |      |        |
|     |           |      |        |
|     |           |      |        |

|  |                           |   |
|--|---------------------------|---|
|  Tél: (450) 979-4373<br>Fax: (450) 979-4626<br><a href="http://www.exmweb.com">www.exmweb.com</a> |                           | Flatness<br>Aplatissement<br>Max 3.0mm<br>Projection<br> |
| Customer<br>Client   | Date                      |   |
| Drawn By<br>Dessiné Par  | BoxCad: BoxCad            | Date 15-Jan-13  |
| Material<br>Matière  | 16 Ga H.R.P. & O. (1.4mm) |   |
| Color<br>Couleur   | Asa-61 Grey               | Finish<br>Fini Smooth   |
| Description  | Detail Rev.               |   |
| 5412ESBU 30" x 12" x 8" Body   |                           |   |
| Part Number<br>Numéro Pièce  | Rev. 0                    | 1 / 7   |
| <b>5412ESBU301208B</b>   |                           |   |

SEE BILL OF MATERIAL ON LAST PAGE

This drawing is confidential and must not be reproduced or used without the consent of EXM

Ce dessin est confidentiel et ne doit pas être reproduit ou utilisé sans le consentement de EXM

| <b>STANDARD FEATURES ARE NOT LISTED IN THIS HOLE TABLE</b> |       |       |                             |
|--|-------|-------|-----------------------------|
| <b>HOLE TABLE - LEFT VIEW (CUSTOM FEATURE ONLY)</b>        |       |       |                             |
| CUT-OUT  | XDIM  | YDIM  | DESCRIPTION                 |
| 1  | 6.500 | 2.000 | GND STUD M6 x 16mm (Inside) |

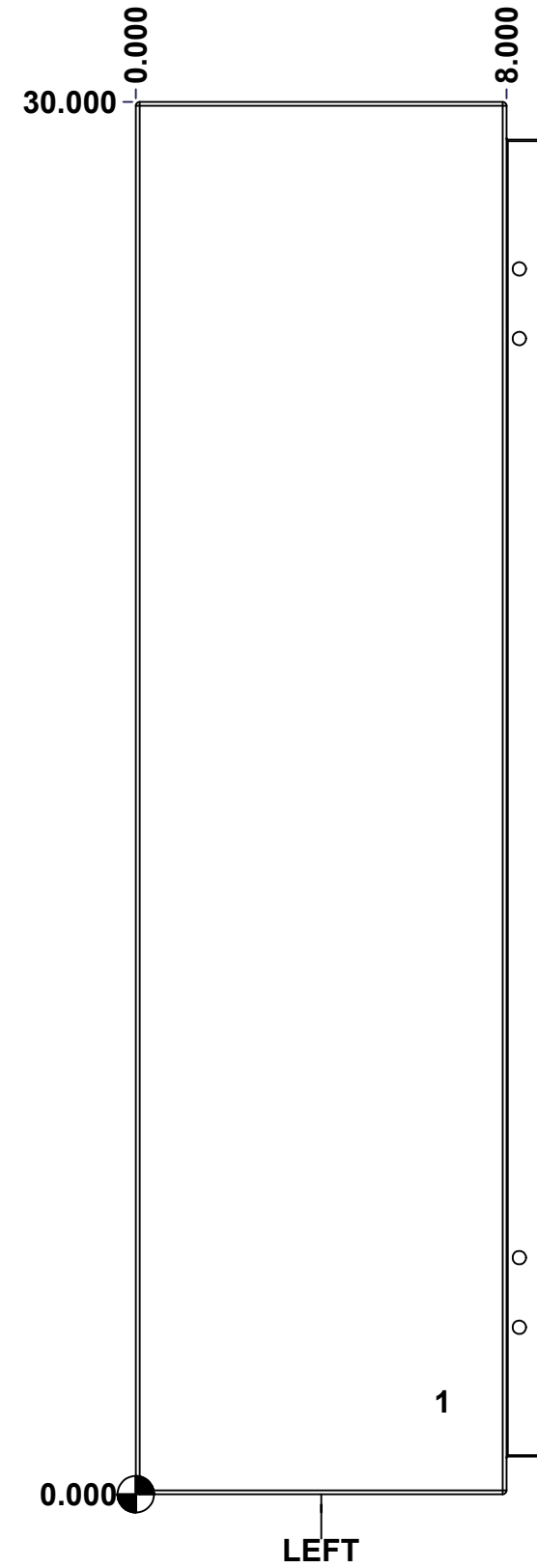

|  |                              |          |       |
|--|------------------------------|----------|-------|
|  | Description                  | Status   |       |
|  | 5412ESBU 30" x 12" x 8" Body |          |       |
|  | Part Number<br>Numéro Pièce  | Rev.     |       |
|  | <b>5412ESBU301208B</b>       | <b>0</b> | 5 / 7 |

This drawing is confidential and must not be reproduced or used without the consent of EXM

Ce dessin est confidentiel et ne doit pas être reproduit ou utilisé sans le consentement de EXM

**STANDARD FEATURES ARE NOT LISTED IN THIS HOLE TABLE**

**HOLE TABLE - BACK VIEW (CUSTOM FEATURE ONLY)**

| CUT-OUT | XDIM   | YDIM   | DESCRIPTION                |
|---------|--------|--------|----------------------------|
| 1       | 1.875  | 1.875  | IP STUD M8 x 35mm (Inside) |
| 2       | 1.875  | 28.125 | IP STUD M8 x 35mm (Inside) |
| 3       | 10.125 | 28.125 | IP STUD M8 x 35mm (Inside) |
| 4       | 10.125 | 1.875  | IP STUD M8 x 35mm (Inside) |
| -----   |        |        |                            |
| 5       | 11.250 | 0.750  | RND Ø0.390                 |
| 6       | 11.250 | 29.250 | RND Ø0.390                 |
| 7       | 0.750  | 29.250 | RND Ø0.390                 |
| 8       | 0.750  | 0.750  | RND Ø0.390                 |

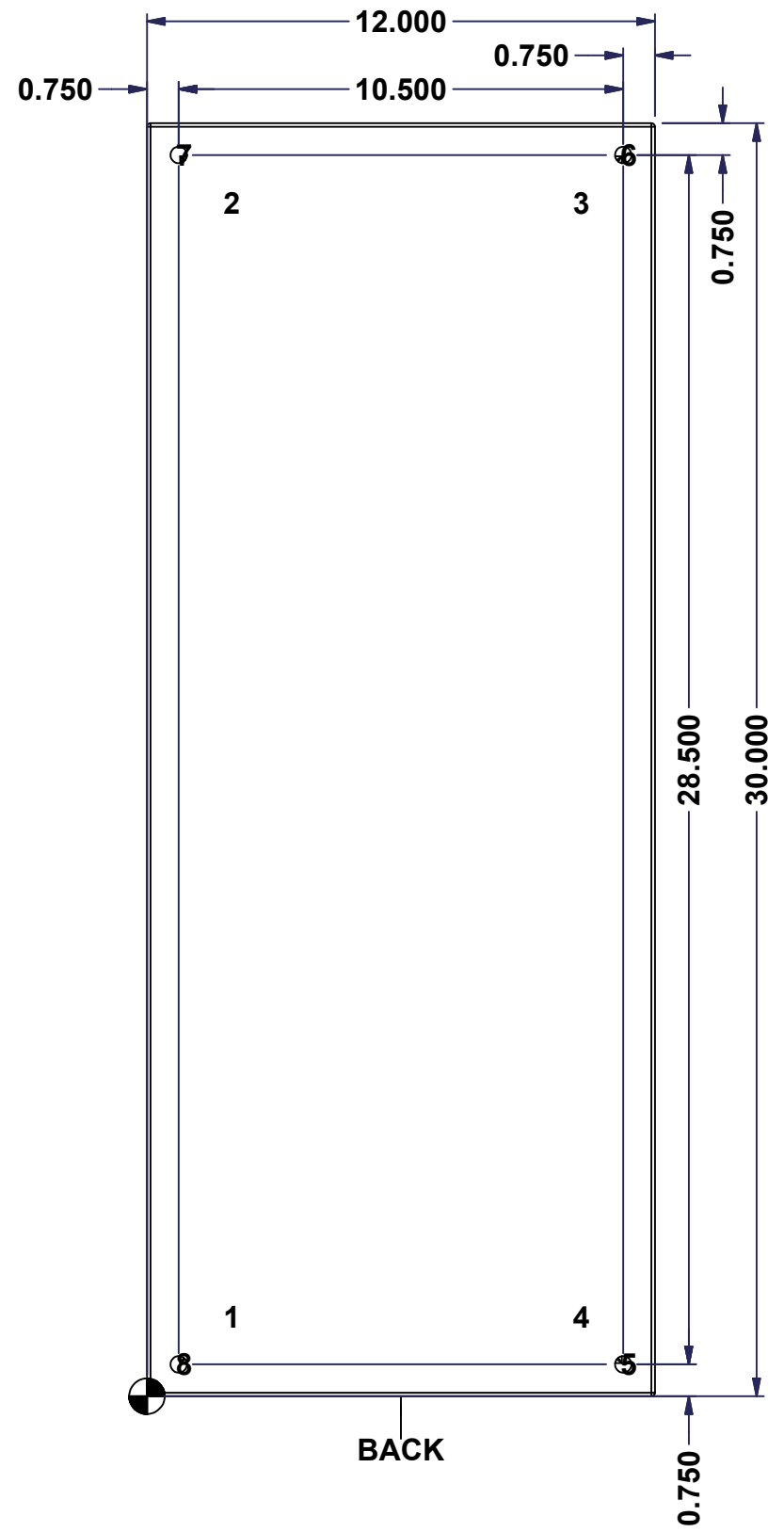

|  |                              |          |
|--|------------------------------|----------|
|  | Description                  | Status   |
|  | 5412ESBU 30" x 12" x 8" Body |          |
|  | Part Number<br>Numéro Pièce  | Rev.     |
|  | <b>5412ESBU301208B</b>       | <b>0</b> |
|  |                              | 6        |
|  |                              | 7        |

This drawing is confidential and must not be reproduced or used without the consent of EXM

Ce dessin est confidentiel et ne doit pas être reproduit ou utilisé sans le consentement de EXM

| No. | Revisions | Date | By/Par |
|-----|-----------|------|--------|
|     |           |      |        |
|     |           |      |        |
|     |           |      |        |
|     |           |      |        |
|     |           |      |        |

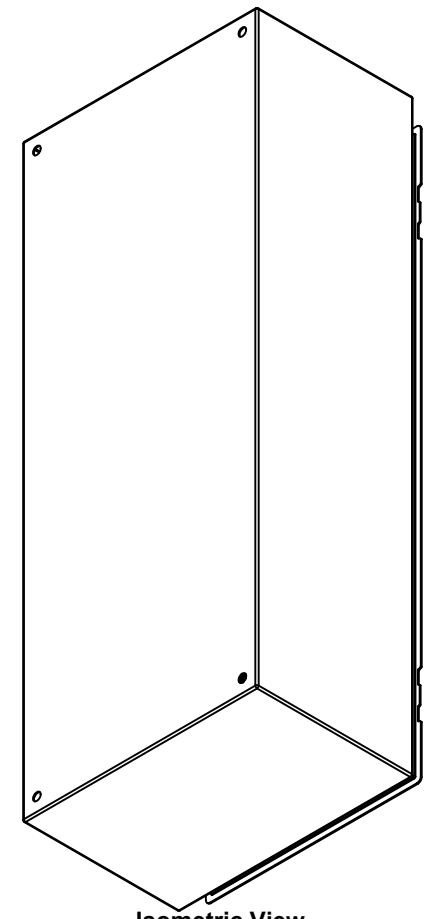

Isometric View

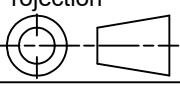

|  |                           |   |
|--|---------------------------|---|
|  Tél: (450) 979-4373<br>Fax: (450) 979-4626<br><a href="http://www.exmweb.com">www.exmweb.com</a> |                           | Flatness<br>Aplatissement<br>Max 3.0mm<br>Projection<br> |
| Customer Client  | Date                      |   |
| Drawn By<br>Dessiné Par  | BoxCad: BoxCad            | Date 15-Jan-13  |
| Material<br>Matière  | 16 Ga H.R.P. & O. (1.4mm) |   |
| Color<br>Couleur   | Asa-61 Grey               | Finish<br>Fini Smooth   |
| Description  | Detail Rev.               |   |
| 5412ESBU 30" x 12" x 8" Body   |                           |   |
| Part Number<br>Numéro Pièce  | Rev.                      | 7   |
| <b>5412ESBU301208B</b>   | <b>0</b>                  | <b>7</b>  |

| Qty        | Part Number       | Rev | Description                          |
|------------|-------------------|-----|--------------------------------------|
| 1          | STK-Q-16080       | 0   | Ground Stud M6 x 16mm                |
| 1          | STK-P-02400S      | 0   | Powder Paint (Asa-61 Grey / Smooth)  |
| 4          | STK-Q-16005       | 1   | Stud M8 x 35 (No Paint Cap Required) |
| 1          | 5412ESBU301208B-P | 0   | 5412ESBU 30" x 12" x 8" Body Part    |
| Parts List |                   |     |                                      |

This drawing is confidential and must not be reproduced or used without the consent of EXM

Ce dessin est confidentiel et ne doit pas être reproduit ou utilisé sans le consentement de EXM

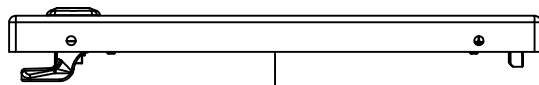

TOP

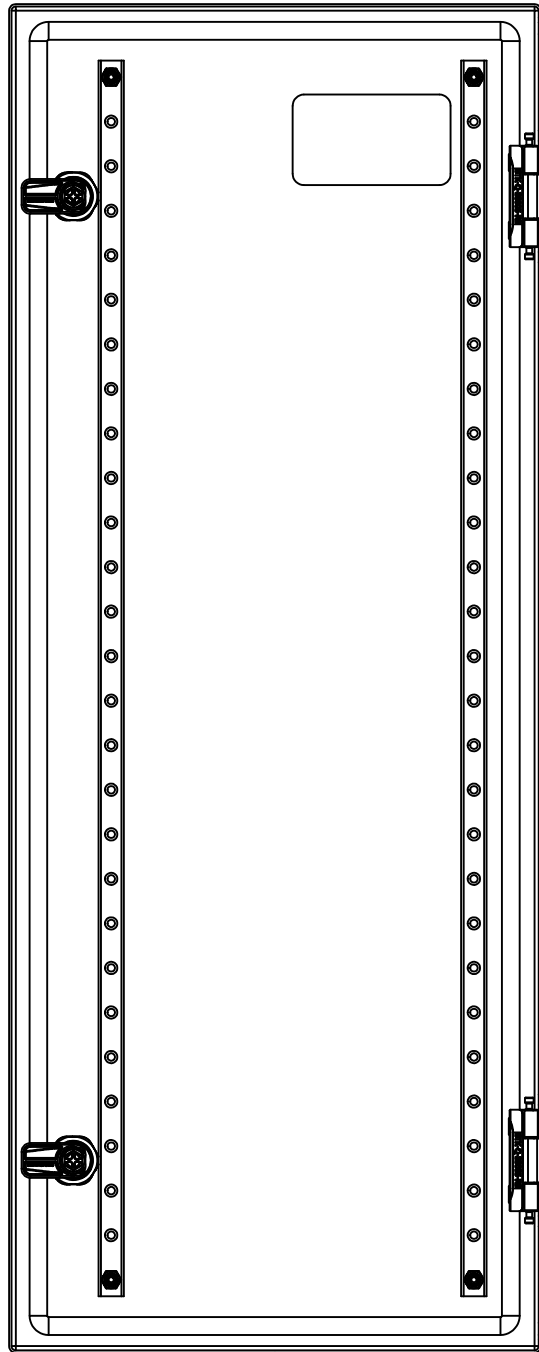

BACK

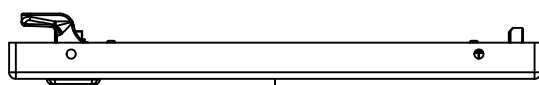

BOTTOM

0.000  
0.800

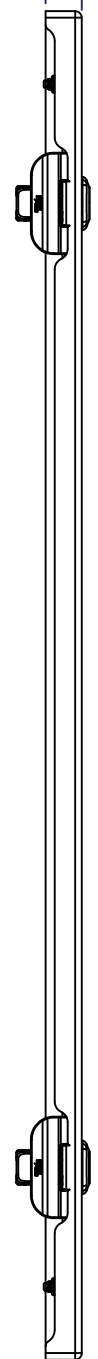

LEFT

0.000

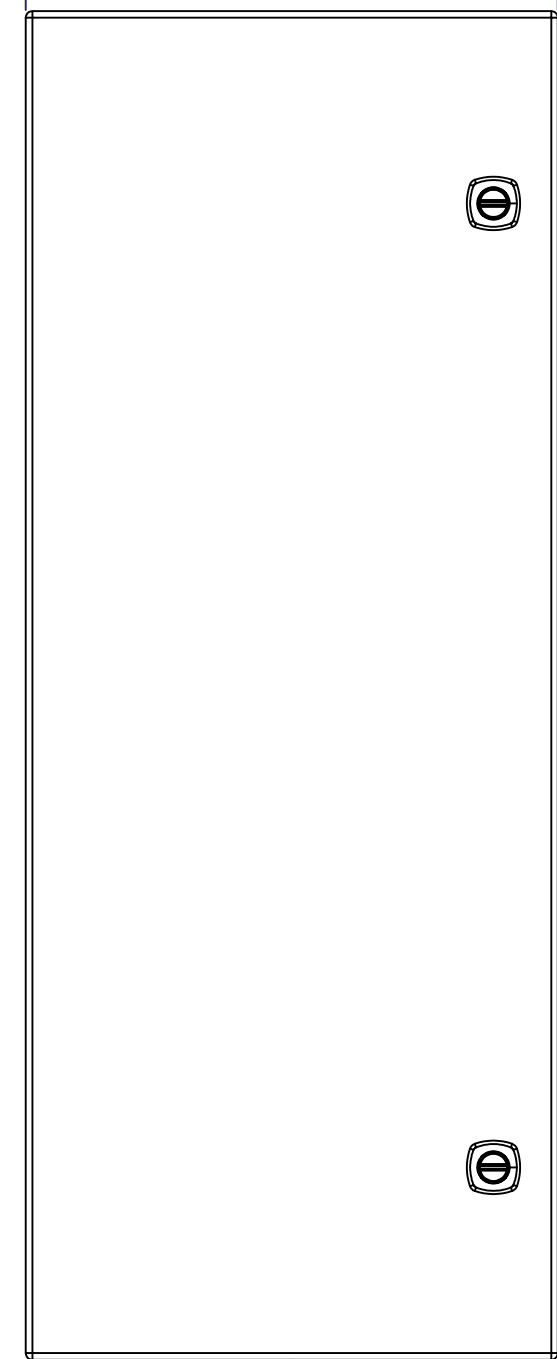

FRONT

11.778

29.803

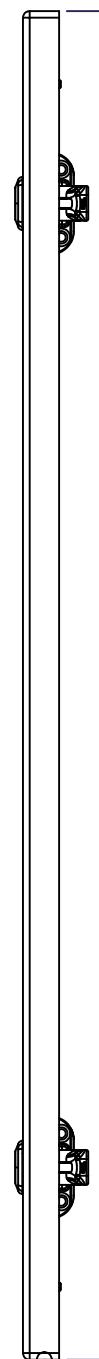

RIGHT

0.000

| No. | Revisions | Date | By/Par |
|-----|-----------|------|--------|
|     |           |      |        |
|     |           |      |        |
|     |           |      |        |
|     |           |      |        |
|     |           |      |        |

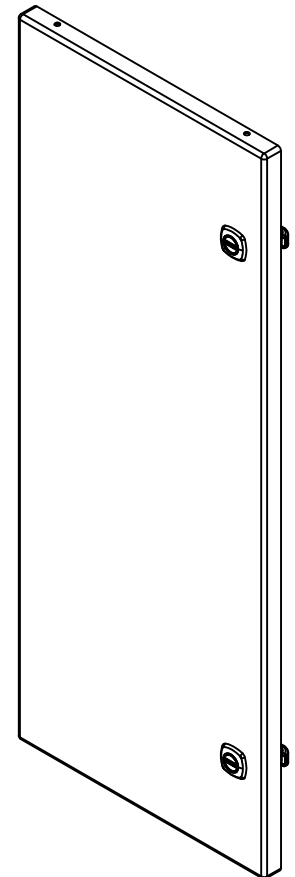

Isometric View



Tél: (450) 979-4373  
Fax: (450) 979-4626  
[www.exmweb.com](http://www.exmweb.com)

Flatness  
Aplatissement  
Max 3.0mm  
Projection

Customer Client  
Date  
Drawn By / Dessiné Par: BoxCad: BoxCad  
Date: 15-Jan-13

Material / Matière: 16 Ga H.R.P. & O. (1.4mm)

Color / Couleur: Asa-61 Grey  
Finish / Fini: Smooth

Description: 5412ESBU 30" x 12" Cover  
Detail Rev.

Part Number / Numéro Pièce: 5412ESBU301208C  
Rev. 0  
1 / 3

SEE BILL OF MATERIAL ON LAST PAGE

This drawing is confidential and must not be reproduced or used without the consent of EXM

Ce dessin est confidentiel et ne doit pas être reproduit ou utilisé sans le consentement de EXM

**STANDARD FEATURES ARE NOT LISTED IN THIS HOLE TABLE**

**HOLE TABLE - FRONT VIEW (CUSTOM FEATURE ONLY)**

| CUT-OUT | XDIM   | YDIM   | DESCRIPTION                 |
|---------|--------|--------|-----------------------------|
| 1       | 1.486  | 1.614  | STUD M6 x 18mm (Inside)     |
| 2       | 1.486  | 28.189 | STUD M6 x 18mm (Inside)     |
| 3       | 9.517  | 28.189 | STUD M6 x 18mm (Inside)     |
| 4       | 9.517  | 1.614  | STUD M6 x 18mm (Inside)     |
| -----   |        |        |                             |
| 5       | 10.354 | 25.553 | LOCK 880 SCQ4-SL @ 0.0°     |
| 6       | 10.354 | 4.250  | LOCK 880 SCQ4-SL @ 0.0°     |
| 7       | 1.486  | 1.614  | GND STUD M6 x 16mm (Inside) |
| 8       | 3.750  | 26.803 | LABEL_EXM (Inside)          |

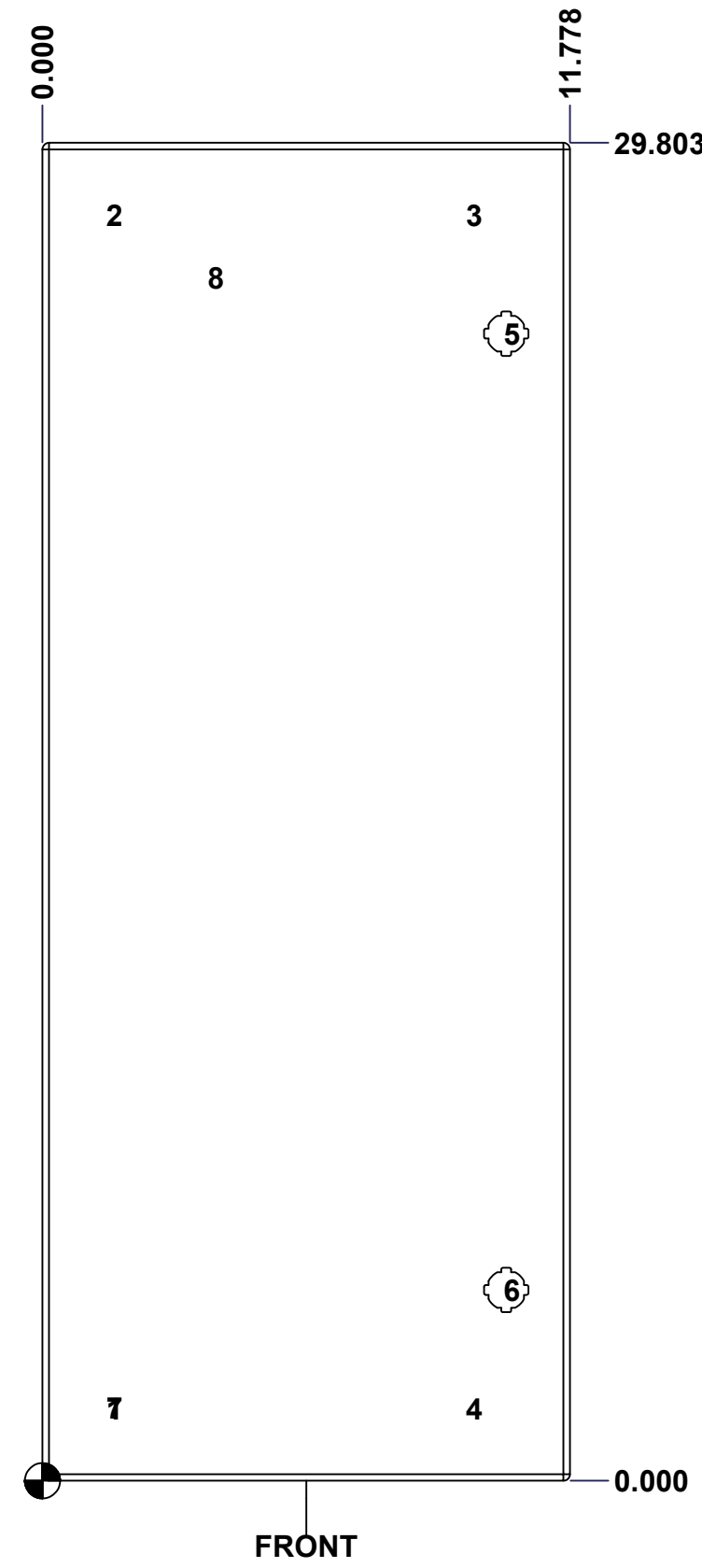

|  |                             |          |
|--|-----------------------------|----------|
|  | Description                 | Status   |
|  | 5412ESBU 30" x 12" Cover    | (NULL)   |
|  | Part Number<br>Numéro Pièce | Rev.     |
|  | <b>5412ESBU301208C</b>      | <b>0</b> |
|  |                             | 2        |
|  |                             | 3        |



This drawing is confidential and must not be reproduced or used without the consent of EXM

Ce dessin est confidentiel et ne doit pas être reproduit ou utilisé sans le consentement de EXM

| No. | Revisions | Date | By/Par |
|-----|-----------|------|--------|
|     |           |      |        |
|     |           |      |        |
|     |           |      |        |
|     |           |      |        |
|     |           |      |        |

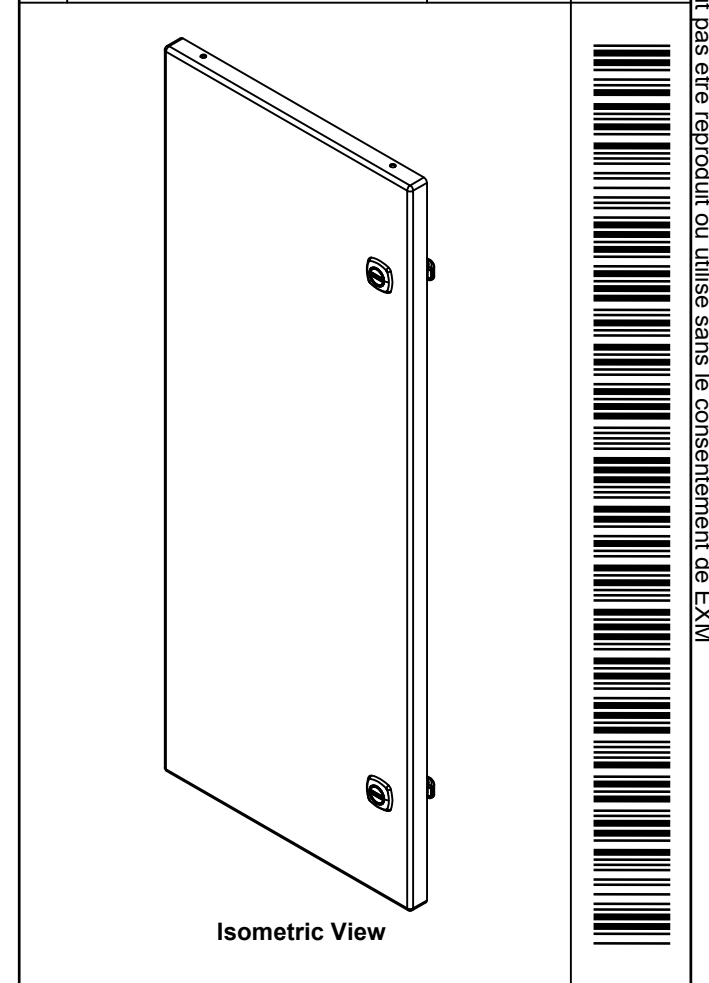

 Tél: (450) 979-4373  
 Fax: (450) 979-4626  
[www.exmweb.com](http://www.exmweb.com)

Flatness Aplatissement  
 Max 3.0mm  
 Projection 

| 1          | STK-S-00100       | 0   | 3.5" x 2" Silver Milar Flexcon Sticker |
|------------|-------------------|-----|--|
| 1          | STK-Q-16080       | 0   | Ground Stud M6 x 16mm                  |
| 1          | STK-P-02400S      | 0   | Powder Paint (Asa-61 Grey / Smooth)    |
| 4          | STK-Q-16055       | 1   | M6 x 18mm Stud (No Paint Cap Required) |
| 1          | 5412ESBU301208G   | 0   | 5412ESBU 30" x 12" Cover Gasket Part   |
| 2          | STK-A-33005       | 4   | 5412 ESBU Hinge 180° (Body Part)       |
| 2          | STK-Q-46020-30    | 5   | 5412 ES Vertical Door Stiffener 30"    |
| 1          | 5412ESBU301208C-P | 0   | 5412ESBU 30" x 12" Cover Part          |
| 2          | 880 SCQ4-SL       | 6   | 5412 ES 1/4 Turn Lock                  |
| 4          | STK-Q-07220       | 1   | M6 Nylon Insert Lock Nut               |
| Qty        | Part Name         | Rev | Description                            |
| Parts List |                   |     |  |

Customer Client \_\_\_\_\_ Date \_\_\_\_\_

Drawn By Dessiné Par BoxCad: BoxCad Date 15-Jan-13

Material Matière 16 Ga H.R.P. & O. (1.4mm)

Color Couleur Asa-61 Grey Finish Fini Smooth

Description 5412ESBU 30" x 12" Cover Detail Rev. \_\_\_\_\_

Part Number Numéro Pièce **5412ESBU301208C** Rev. **0** 3

This drawing is confidential and must not be reproduced or used without the consent of EXM

Ce dessin est confidentiel et ne doit pas être reproduit ou utilisé sans le consentement de EXM

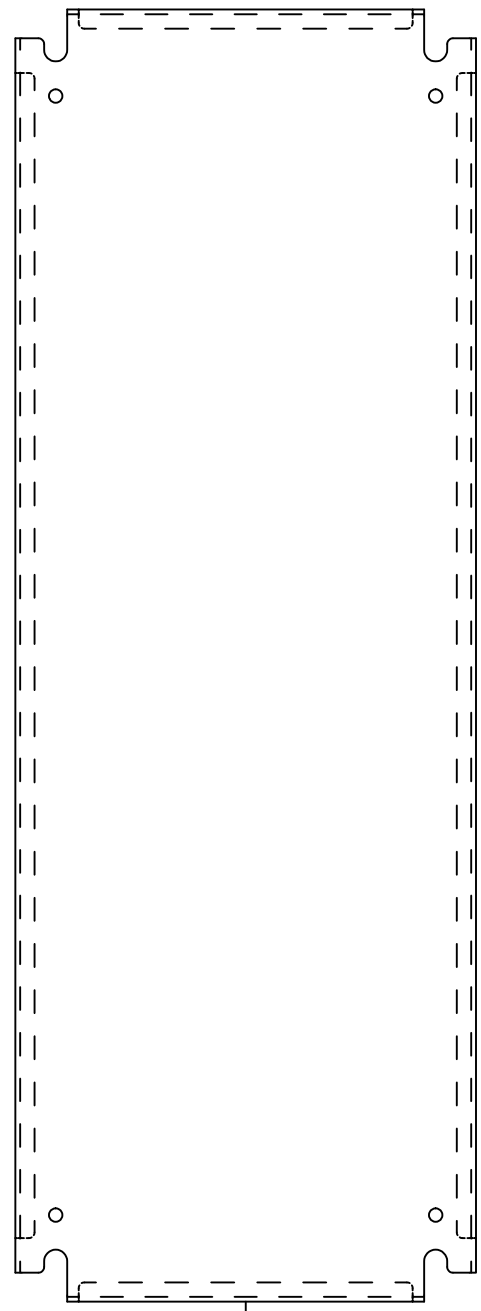
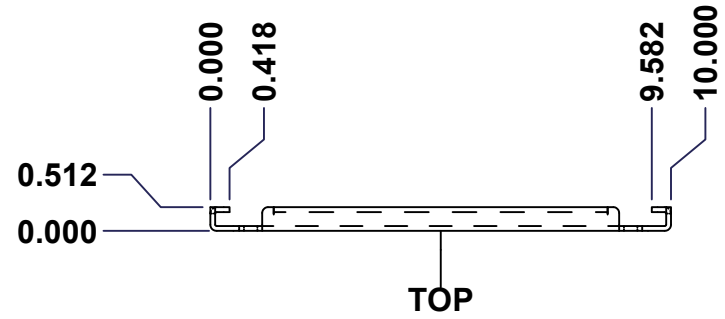

FRONT

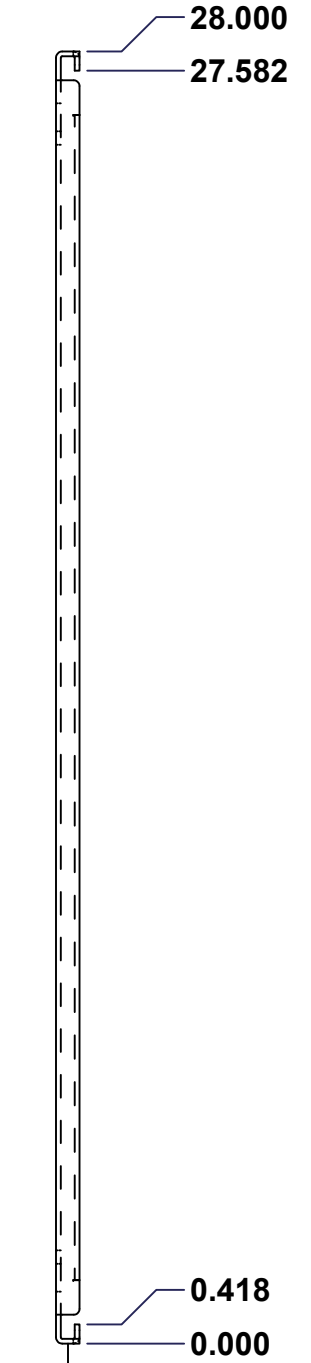

RIGHT

| No. | Revisions | Date | By/Par |
|-----|-----------|------|--------|
|     |           |      |        |
|     |           |      |        |
|     |           |      |        |
|     |           |      |        |

Isometric View

|  |  |  |                    |
|--|--|--|--------------------|
|  |  | Flatness<br>Aplatissement<br>Max 3.0mm<br>Projection<br> |                    |
| Tél: (450) 979-4373<br>Fax: (450) 979-4626<br>www.exmweb.com |  | Customer<br>Client                                       |                    |
| Drawn By<br>Dessiné Par BoxCad                               |  | Date<br>1/23/2007  |                    |
| Material<br>Matière See Part List                            |  |  |                    |
| Color<br>Couleur See Part List                               |  | Finish<br>Fini See Part List                             |                    |
| Description<br>881 SP - Inner Panel                          |  |  | Detail Rev.        |
| Part Number<br>Numéro Pièce<br><b>881 SP3012G</b>            |  |  | Rev. 1<br><b>0</b> |

| Qty        | Part Number   | Rev | Description               | Material         | Color     | Finish     |
|------------|---------------|-----|---------------------------|------------------|-----------|------------|
| 1          | 881 SP3012G-P | 0   | 881 SP - Inner Panel Part | 12 Ga Galvanized | Unpainted | Galvanized |
| Parts List |               |     |                           |                  |           |            |

This drawing is confidential and must not be reproduced or used without the consent of EXM

Ce dessin est confidentiel et ne doit pas être reproduit ou utilisé sans le consentement de EXM

| Table 1 |       |        | FRONT VIEW               |
|---------|-------|--------|--------------------------|
| CUT-OUT | XDIM  | YDIM   | DESCRIPTION              |
| 1       | 0.875 | 1.875  | GROUND HOLE (RND Ø0.290) |
| 2       | 9.125 | 1.875  | GROUND HOLE (RND Ø0.290) |
| 3       | 0.875 | 26.125 | GROUND HOLE (RND Ø0.290) |
| 4       | 9.125 | 26.125 | GROUND HOLE (RND Ø0.290) |

All knockouts are actual size / Les disques défonçables sont grandeur réel

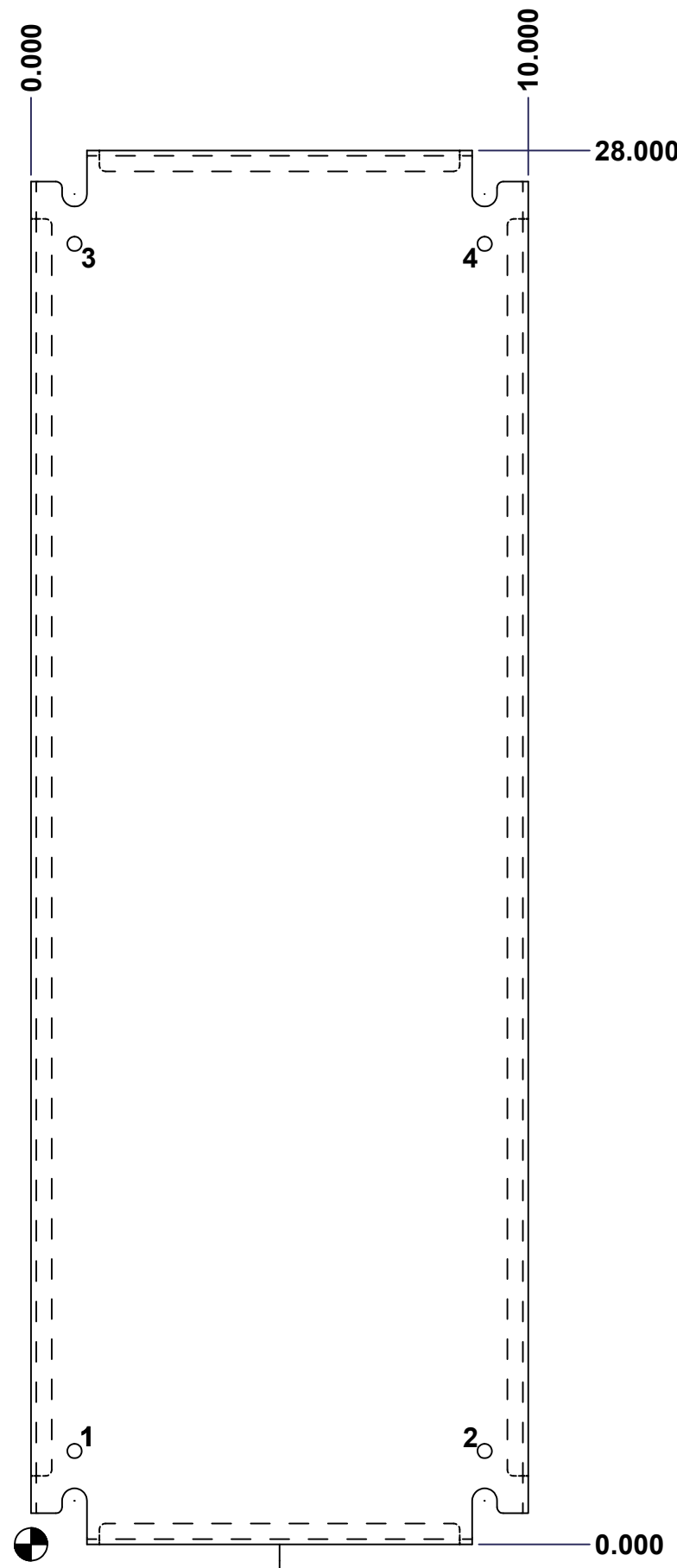

FRONT

| No. | Revisions | Date | By/Par |
|-----|-----------|------|--------|
|     |           |      |        |
|     |           |      |        |
|     |           |      |        |
|     |           |      |        |
|     |           |      |        |

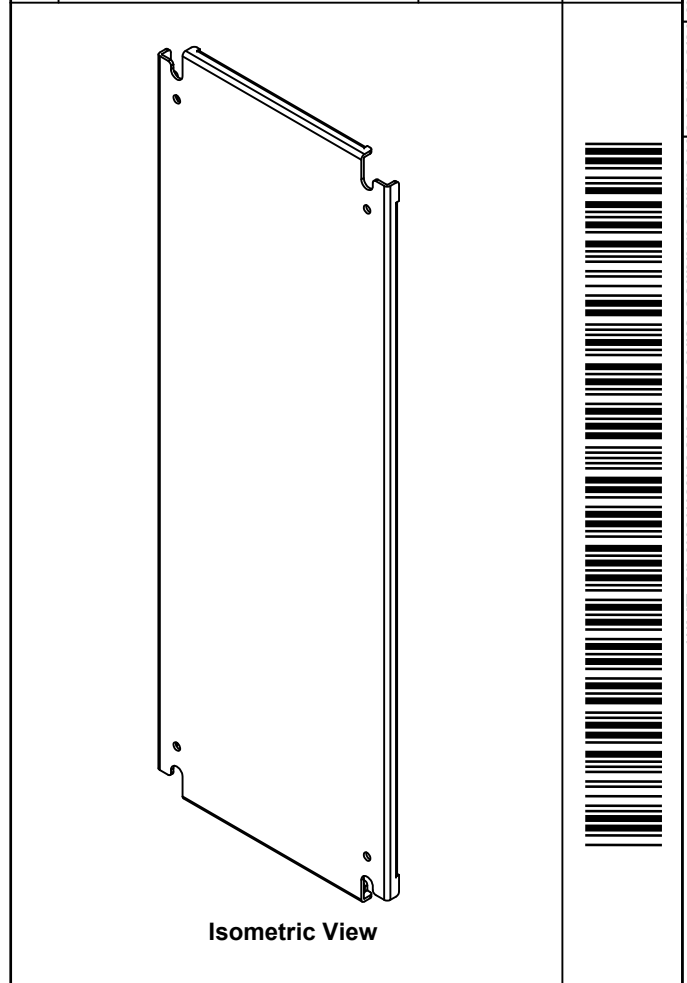

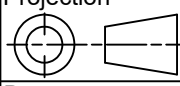
|  |   |
|--|---|
|  Tél: (450) 979-4373<br>Fax: (450) 979-4626<br>www.exmweb.com | Flatness<br>Aplatissement<br>Max 3.0mm  |
|  | Projection<br> |
| Customer Client  | Date  |
| Drawn By<br>Dessiné Par BoxCad   | Date 1/23/2007  |
| Material<br>Matière  | See Part List   |
| Color<br>Couleur   | See Part List   |
| Finish<br>Fini   | See Part List   |
| Description<br>881 SP - Inner Panel  | Detail Rev.   |
| Part Number<br>Numéro Pièce<br><b>881 SP3012G</b>  | Rev. 0  |



2 / 2