

This drawing is confidential and must not be reproduced or used without the consent of EXM

Ce dessin est confidentiel et ne doit pas être reproduit ou utilisé sans le consentement de EXM

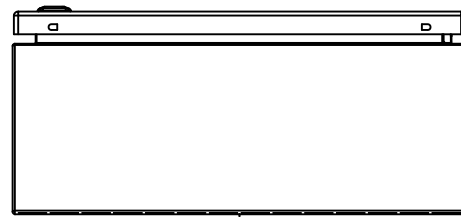

TOP



BACK

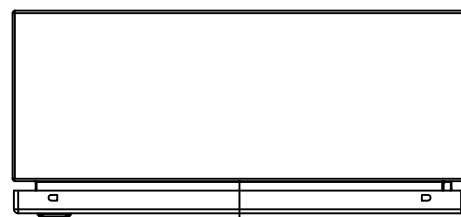

BOTTOM

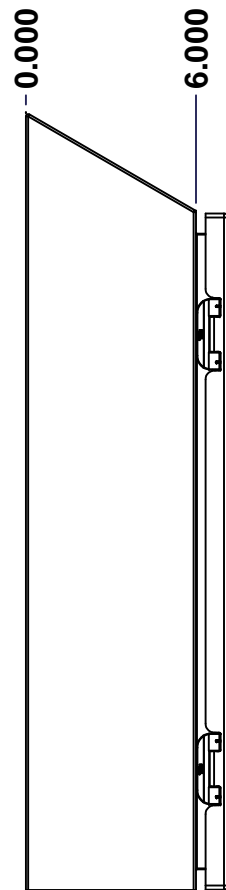

LEFT

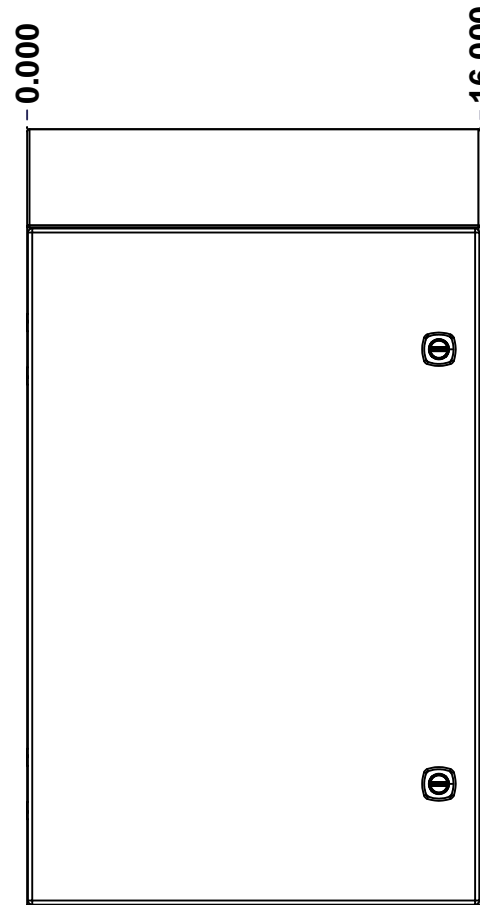

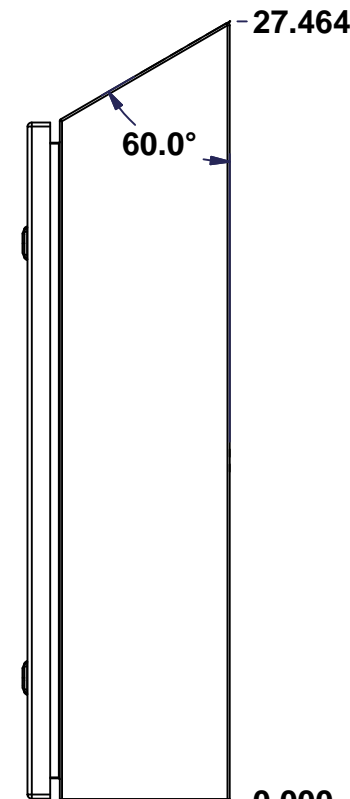

FRONT

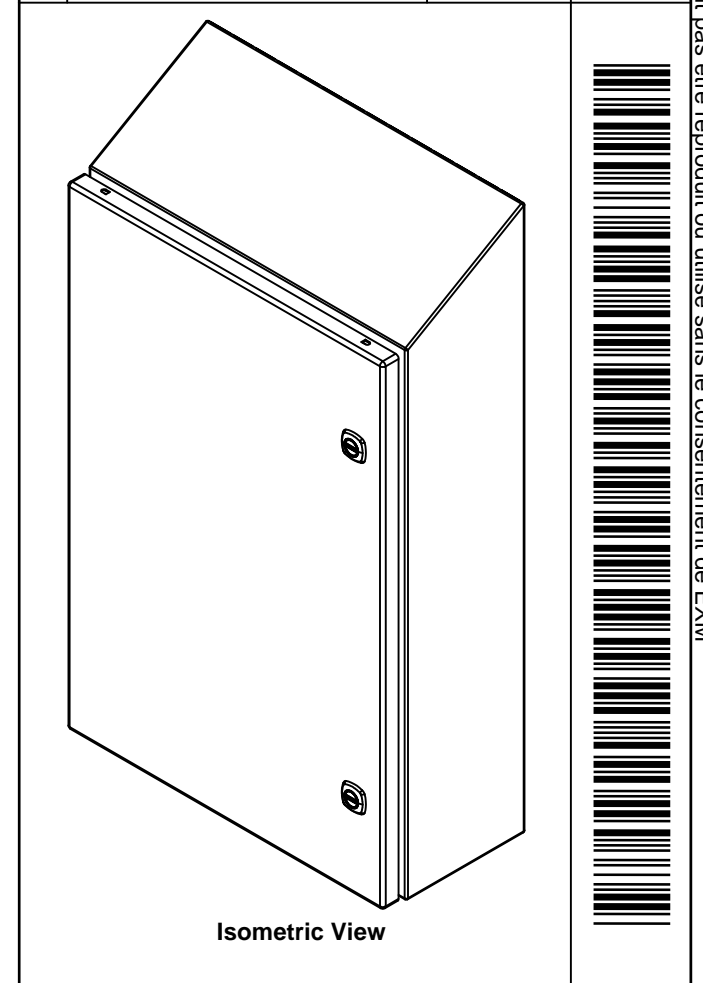

RIGHT

| No. | Revisions | Date | By/Par |
|-----|-----------|------|--------|
| | | | |
| | | | |
| | | | |
| | | | |

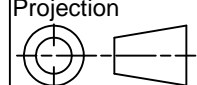

| | | |
|--|------------------------------|---|
|  Tél: (450) 979-4373 Fax: (450) 979-4626 www.exmweb.com | | Flatness Aplatissement Max 3.0mm Projection  |
| Customer Client | Date | |
| Drawn By / Dessiné Par: BoxCad: BoxCad | Date: 17-Feb-16 | |
| Material / Matière: 16 Ga Cold Rolled A1008 CS Type B (1.4mm) | Color / Couleur: Asa-61 Grey | |
| Description: 5412ESCS 24" x 16" x 6" Assembly | | Finish / Fini: Smooth |
| Part Number / Numéro Pièce: 5412ESCS241606 | Detail Rev.: | Rev. 1/2 |

SEE BILL OF MATERIAL ON LAST PAGE

This drawing is confidential and must not be reproduced or used without the consent of EXM

Ce dessin est confidentiel et ne doit pas être reproduit ou utilisé sans le consentement de EXM

| NOTE | |
|------|--|
| ITEM | DESCRIPTION |
| 1 | NEMA 4/12 Enclosure |
| 2 | C/W Standard ground studs on box and cover |
| 3 | C/W Standard door stiffener |
| 4 | C/W Standard inner panel (Included) |
| 5 | C/W Standard inner panel mounting studs |

| No. | Revisions | Date | By/Par |
|-----|-----------|------|--------|
| | | | |
| | | | |
| | | | |
| | | | |
| | | | |
| | | | |

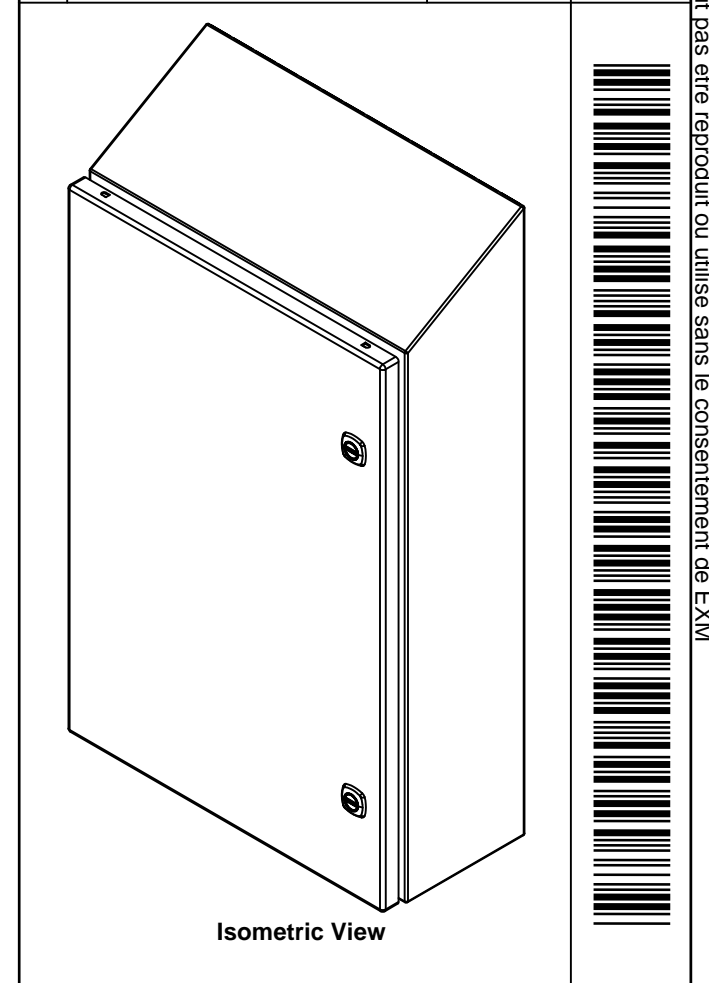



Tél: (450) 979-4373
Fax: (450) 979-4626
www.exmweb.com

Flatness
Aplatissement
Max 3.0mm
Projection

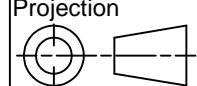

| | |
|---|-----------------------|
| Customer Client | Date |
| Drawn By / Dessiné Par: BoxCad: BoxCad | Date: 17-Feb-16 |
| Material / Matière: 16 Ga Cold Rolled A1008 CS Type B (1.4mm) | |
| Color / Couleur: Asa-61 Grey | Finish / Fini: Smooth |

| PACKING | | |
|-----------------------|-----|--|
| ITEM | QTY | DESCRIPTION |
| Cardboard sleeve | 2 | Top and Bottom |
| Cardboard strip | 2 | Between back of enclosure and inner panel |
| Plastic bag | 1 | To protect cover surface and inside gasket |
| Plastic strap - Black | 2 | To Squeeze the 2 cardboard sleeve together |
| Packaging label | 1 | White label with product number |

| | | | |
|------------|-----------------|-----|--|
| 1 | 880 PP | 6 | Self Adhesive Print Pocket |
| 1 | 881 SP2416G | 0 | 881 SP - Inner Panel |
| 1 | STK-K-01800 | 5 | 5412 ES Accessory Kit |
| 1 | 5412ESCS241606C | 0 | 5412ESCS 24" x 16" Cover |
| 4 | STK-Q-07310 | 2 | Flange Lock Nut M8 |
| 4 | STK-Q-07610 | 8 | M8 Plastic Spacer 22.2mm |
| 1 | 5412ESCS241606B | 0 | 5412ESCS 24" x 16" x 6" Body |
| 2 | STK-Q-04050-07 | 7 | M6 x 7mm Hexagon Socket Head Machine Screw with Nyseal |
| Qty | Part Number | Rev | Description |
| Parts List | | | |

| | |
|---|---------------|
| Description: 5412ESCS 24" x 16" x 6" Assembly | Detail Rev. |
| Part Number / Numéro Pièce: 5412ESCS241606 | Rev. 0 |
| | 2 |

This drawing is confidential and must not be reproduced or used without the consent of EXM

Ce dessin est confidentiel et ne doit pas être reproduit ou utilisé sans le consentement de EXM

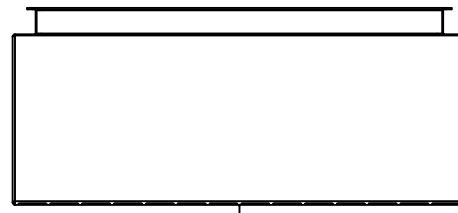

TOP



BACK

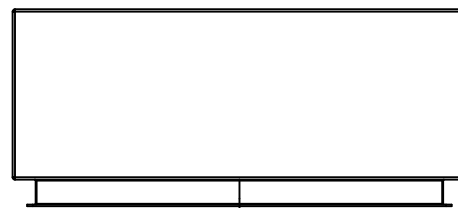

BOTTOM

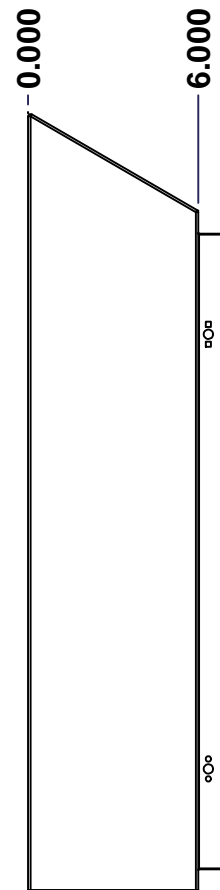

LEFT

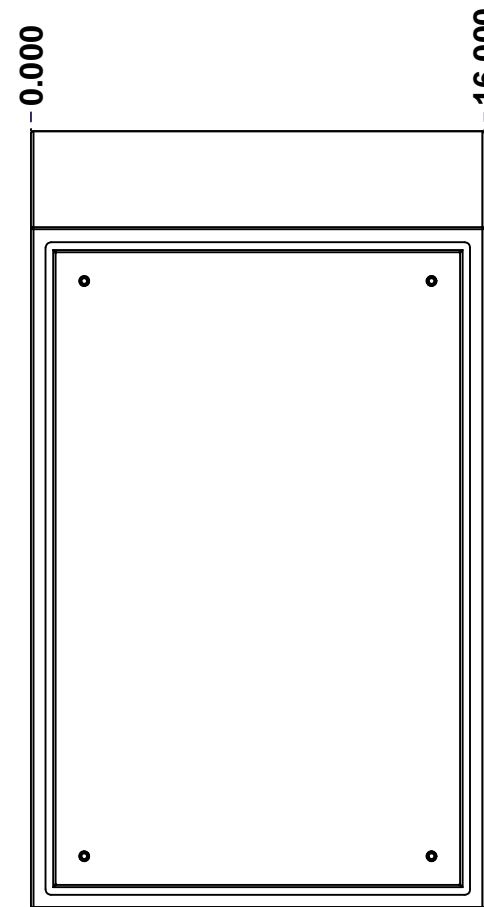

FRONT

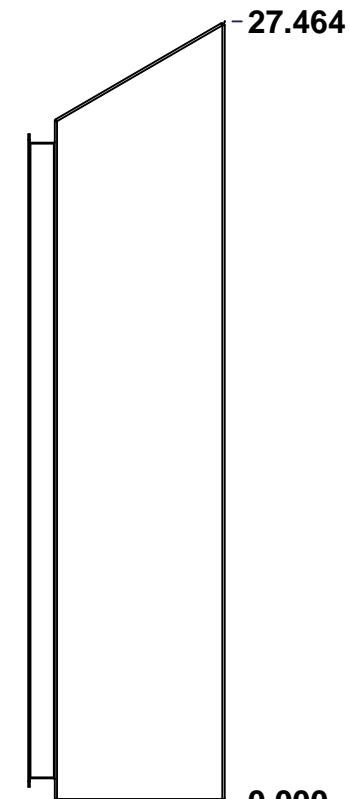

RIGHT

| No. | Revisions | Date | By/Par |
|-----|-----------|------|--------|
| | | | |
| | | | |
| | | | |
| | | | |

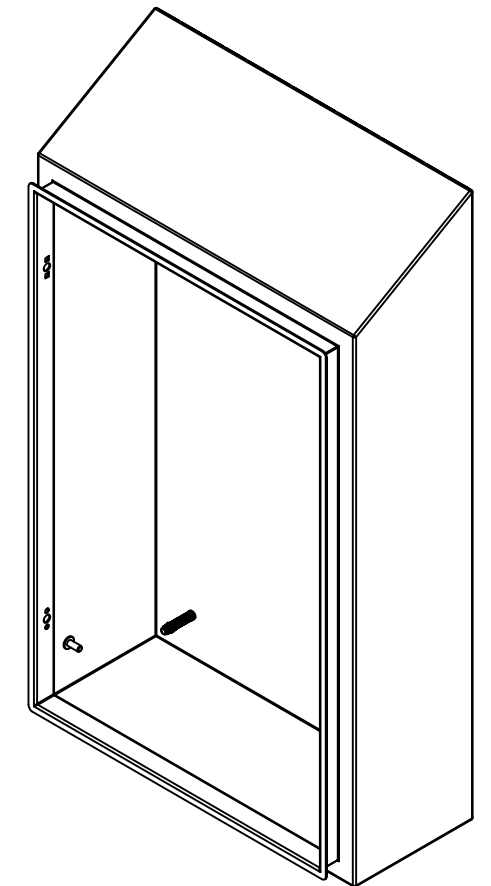

Isometric View



Tél: (450) 979-4373
 Fax: (450) 979-4626
www.exmweb.com

Flatness
Aplatissement

Max 3.0mm

Projection

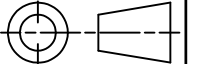

| | |
|---|-----------------------|
| Customer Client | Date |
| Drawn By / Dessiné Par: BoxCad: BoxCad | Date: 17-Feb-16 |
| Material / Matière: 16 Ga Cold Rolled A1008 CS Type B (1.4mm) | |
| Color / Couleur: Asa-61 Grey | Finish / Fini: Smooth |
| Description: 5412ESCS 24" x 16" x 6" Body | Detail Rev. |
| Part Number / Numéro Pièce: 5412ESCS241606B | Rev. 1 0 |

SEE BILL OF MATERIAL ON LAST PAGE

This drawing is confidential and must not be reproduced or used without the consent of EXM

Ce dessin est confidentiel et ne doit pas être reproduit ou utilisé sans le consentement de EXM

| STANDARD FEATURES ARE NOT LISTED IN THIS HOLE TABLE | | | |
|--|-------|-------|-----------------------------|
| HOLE TABLE - LEFT VIEW (CUSTOM FEATURE ONLY) | | | |
| CUT-OUT | XDIM | YDIM | DESCRIPTION |
| 1 | 4.500 | 2.000 | GND STUD M6 x 16mm (Inside) |

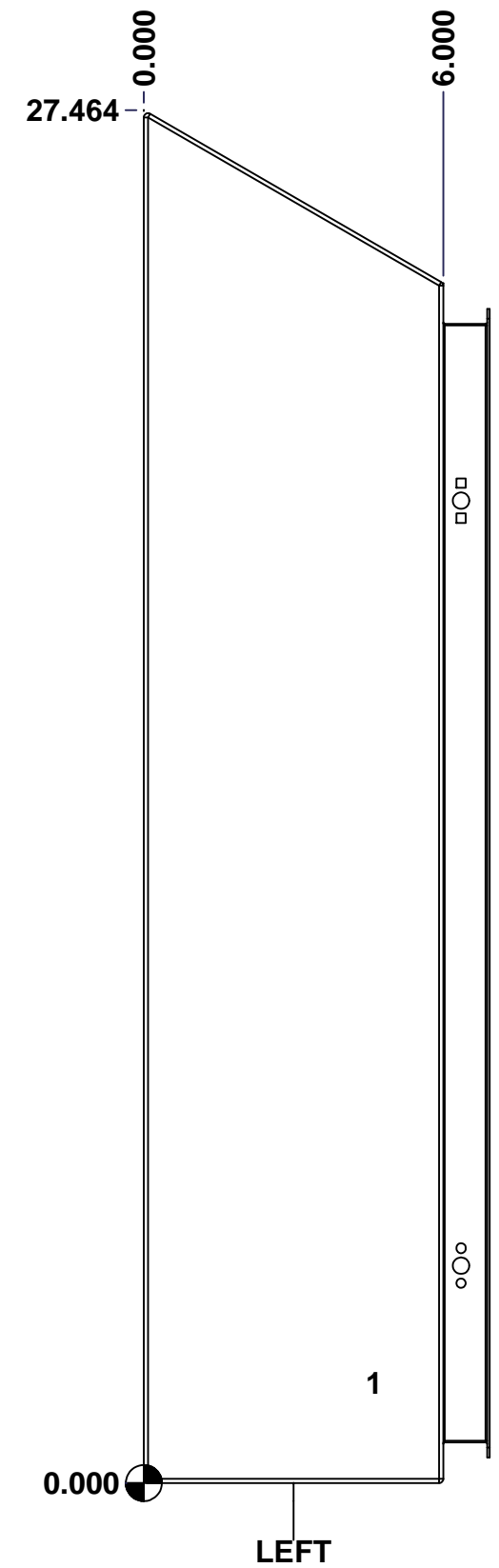

| | | | |
|--|------------------------------|----------|--------|
| | Description | Status | |
| | 5412ESCS 24" x 16" x 6" Body | | |
| | Part Number Numéro Pièce | Rev. | 5 7 |
| | 5412ESCS241606B | 0 | |

This drawing is confidential and must not be reproduced or used without the consent of EXM

Ce dessin est confidentiel et ne doit pas être reproduit ou utilisé sans le consentement de EXM

STANDARD FEATURES ARE NOT LISTED IN THIS HOLE TABLE

HOLE TABLE - BACK VIEW (CUSTOM FEATURE ONLY)

| CUT-OUT | XDIM | YDIM | DESCRIPTION |
|---------|--------|--------|----------------------------|
| 1 | 1.875 | 1.875 | IP STUD M8 x 35mm (Inside) |
| 2 | 1.875 | 22.125 | IP STUD M8 x 35mm (Inside) |
| 3 | 14.125 | 22.125 | IP STUD M8 x 35mm (Inside) |
| 4 | 14.125 | 1.875 | IP STUD M8 x 35mm (Inside) |
| ----- | | | |
| 5 | 15.250 | 0.750 | RND Ø0.390 |
| 6 | 15.250 | 26.714 | RND Ø0.390 |
| 7 | 0.750 | 26.714 | RND Ø0.390 |
| 8 | 0.750 | 0.750 | RND Ø0.390 |

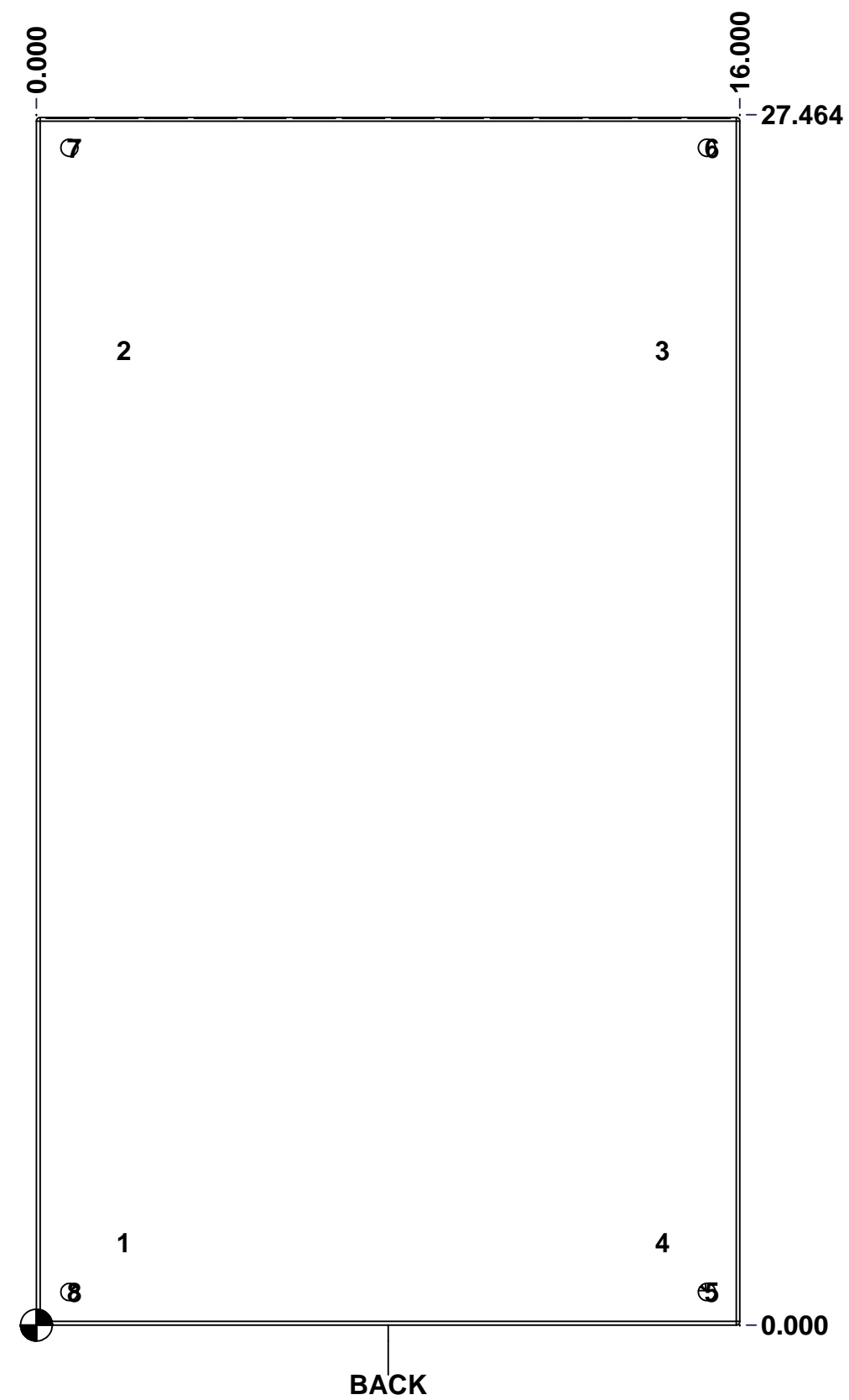

| | | |
|--|------------------------------|----------|
| | Description | Status |
| | 5412ESCS 24" x 16" x 6" Body | |
| | Part Number Numéro Pièce | Rev. |
| | 5412ESCS241606B | 0 |
| | | 6 |
| | | 7 |

This drawing is confidential and must not be reproduced or used without the consent of EXM

Ce dessin est confidentiel et ne doit pas être reproduit ou utilisé sans le consentement de EXM

| No. | Revisions | Date | By/Par |
|-----|-----------|------|--------|
| | | | |
| | | | |
| | | | |
| | | | |
| | | | |

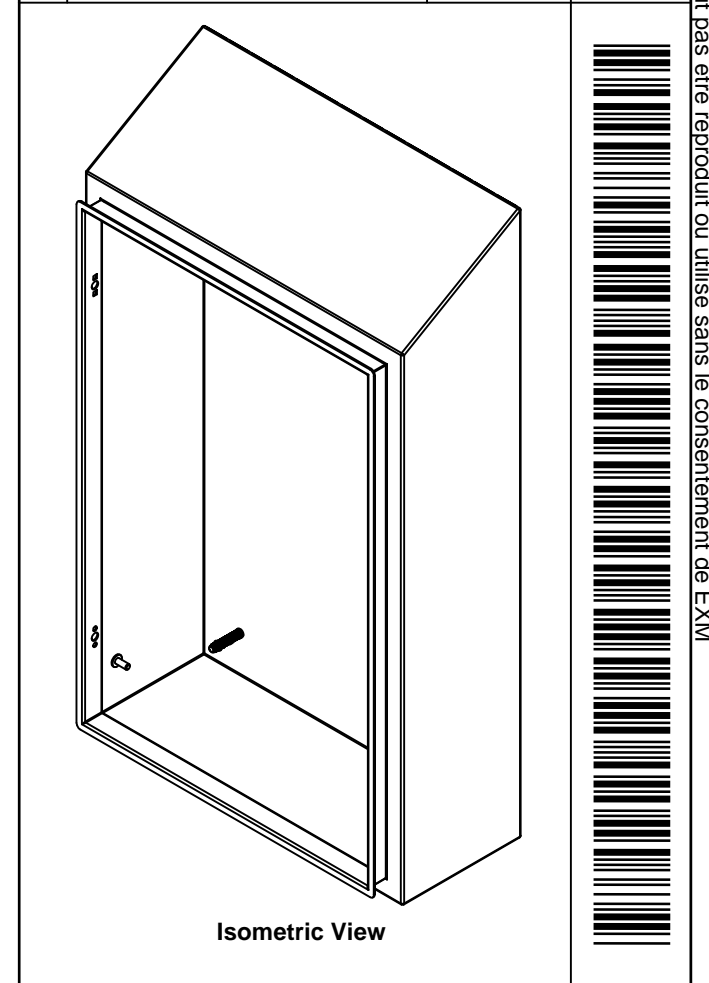

| | | | |
|--|--|---------------------------|-------------|
| Tél: (450) 979-4373 Fax: (450) 979-4626 www.exmweb.com | | Flatness Aplatissement | |
| | | Max 3.0mm Projection | |
| Customer Client | | Date | |
| Drawn By Dessiné Par BoxCad: BoxCad | | Date 17-Feb-16 | |
| Material Matière 16 Ga Cold Rolled A1008 CS Type B (1.4mm) | | | |
| Color Couleur Asa-61 Grey | | Finish Fini Smooth | |
| Description 5412ESCS 24" x 16" x 6" Body | | | Detail Rev. |
| Part Number Numéro Pièce 5412ESCS241606B | | Rev. | 2 |

| Qty | Part Number | Rev. | Description |
|------------|-------------------|------|--|
| 1 | STUD_M6 x 16mm | 0 | Ground Stud M6 x 16mm |
| 1 | STK-P-02400S | 0 | Powder Paint (Asa-61 Grey / Smooth) |
| 4 | STK-Q-16005 | 1 | Stud M8 x 35mm (No Paint Cap Required) |
| 1 | 5412ESCS241606B-P | 0 | 5412ESCS 24" x 16" x 6" Body Part |
| Parts List | | | |

This drawing is confidential and must not be reproduced or used without the consent of EXM

Ce dessin est confidentiel et ne doit pas être reproduit ou utilisé sans le consentement de EXM

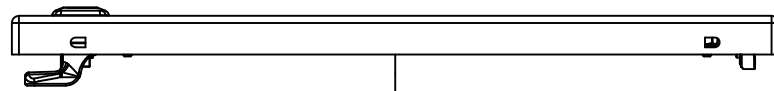

TOP

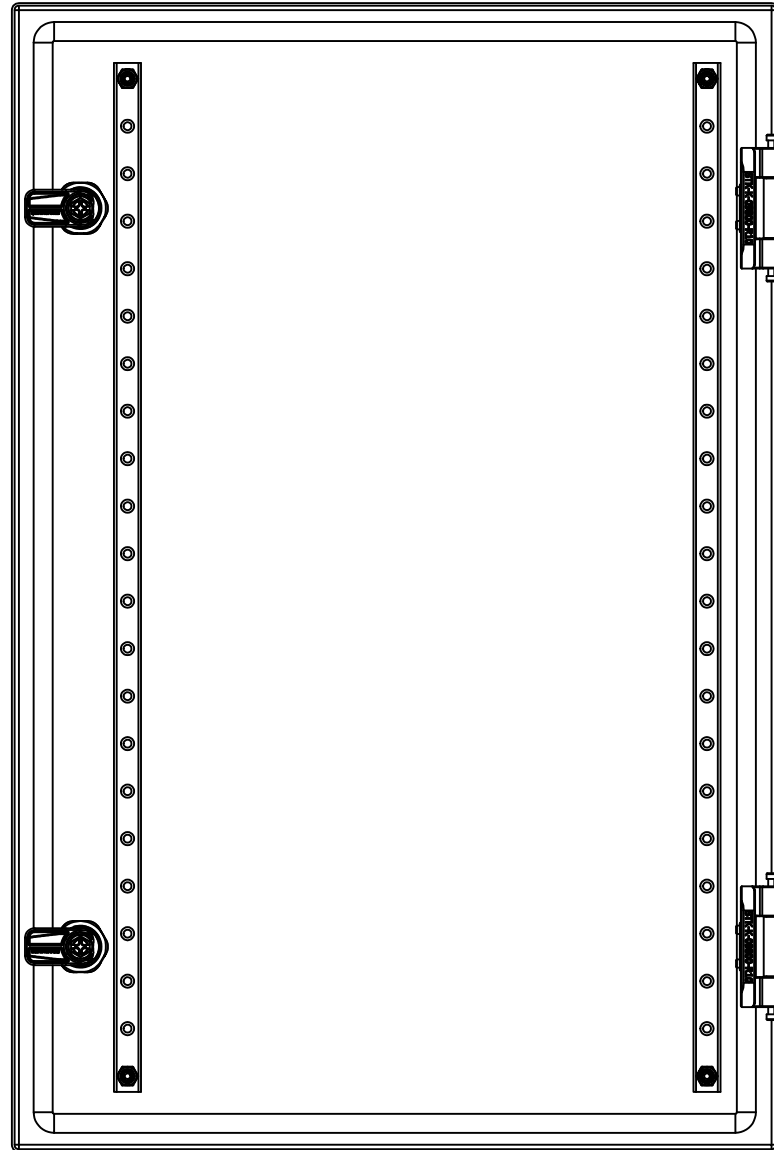

BACK

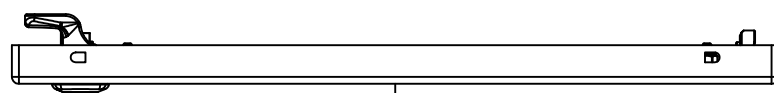

BOTTOM

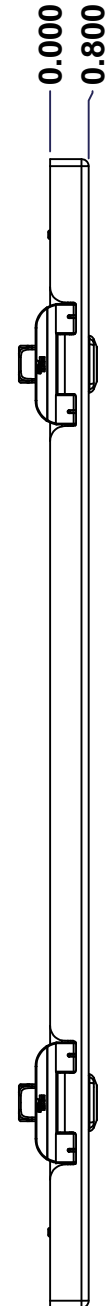

LEFT

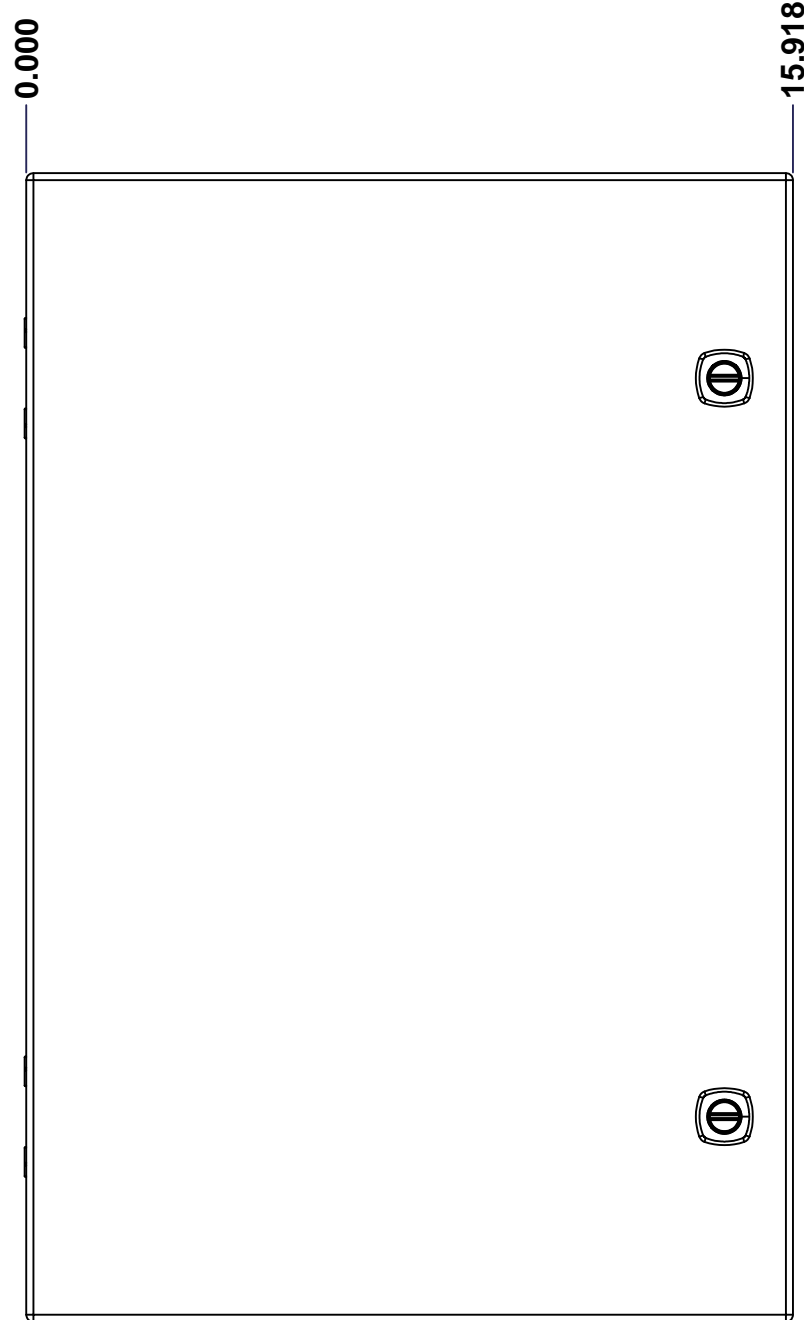

FRONT

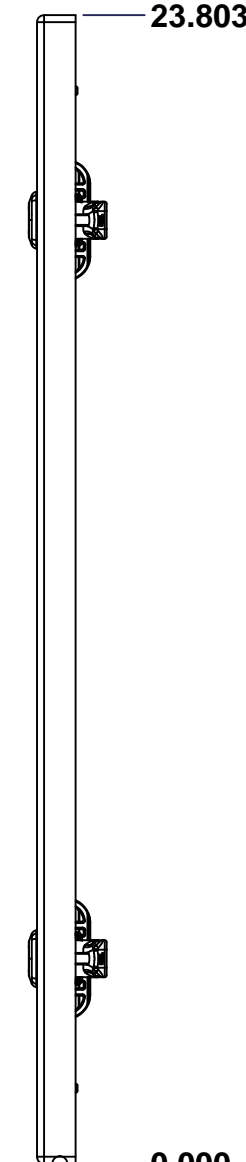

RIGHT

| No. | Revisions | Date | By/Par |
|-----|-----------|------|--------|
| | | | |
| | | | |
| | | | |
| | | | |

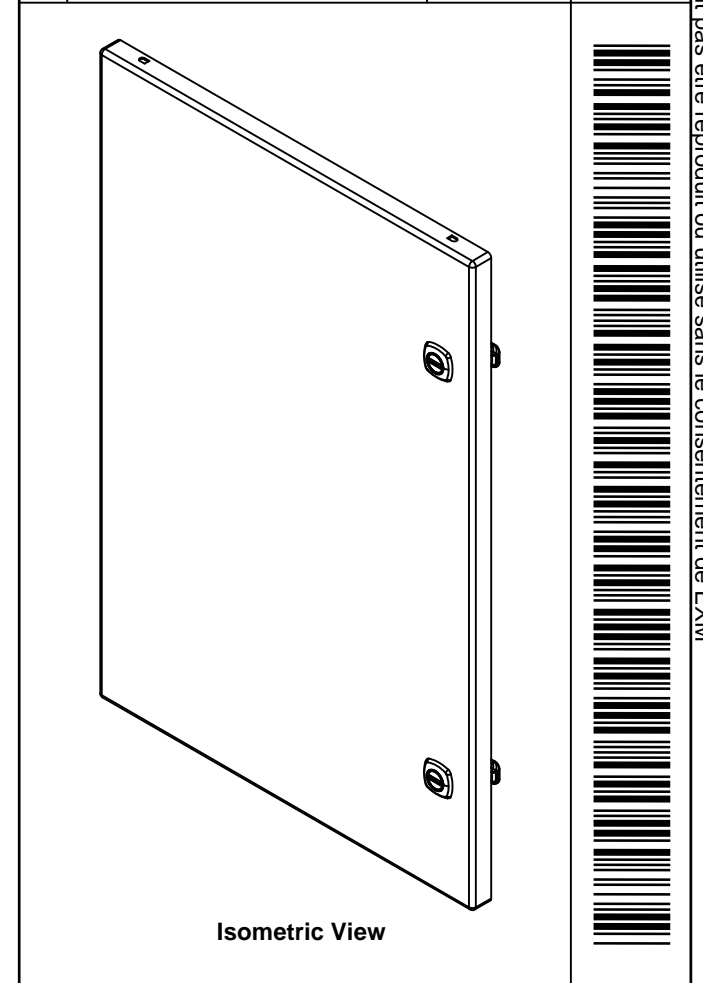

Isometric View

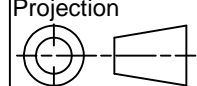
| | | |
|--|---|---|
|  Tél: (450) 979-4373 Fax: (450) 979-4626 www.exmweb.com | | Flatness Aplatissement Max 3.0mm Projection  |
| Customer Client | Date | |
| Drawn By Dessiné Par | BoxCad: BoxCad | Date 17-Feb-16 |
| Material Matière | 16 Ga Cold Rolled A1008 CS Type B (1.4mm) | |
| Color Couleur | Asa-61 Grey | Finish Fini Smooth |
| Description | Detail Rev. | |
| 5412ESCS 24" x 16" Cover | | |
| Part Number Numéro Pièce | Rev. 0 | 1 / 3 |
| 5412ESCS241606C | | |

SEE BILL OF MATERIAL ON LAST PAGE

This drawing is confidential and must not be reproduced or used without the consent of EXM

Ce dessin est confidentiel et ne doit pas être reproduit ou utilisé sans le consentement de EXM

STANDARD FEATURES ARE NOT LISTED IN THIS HOLE TABLE

HOLE TABLE - FRONT VIEW (CUSTOM FEATURE ONLY)

| CUT-OUT | XDIM | YDIM | DESCRIPTION |
|---------|--------|--------|-------------------------|
| 1 | 1.486 | 1.567 | STUD M6 x 18mm (Inside) |
| 2 | 1.486 | 22.236 | STUD M6 x 18mm (Inside) |
| 3 | 13.517 | 22.236 | STUD M6 x 18mm (Inside) |
| 4 | 13.517 | 1.567 | STUD M6 x 18mm (Inside) |
| ----- | | | |
| 5 | 14.494 | 4.250 | LOCK 880 SCQ4-SL @ 0.0° |
| 6 | 14.494 | 19.553 | LOCK 880 SCQ4-SL @ 0.0° |

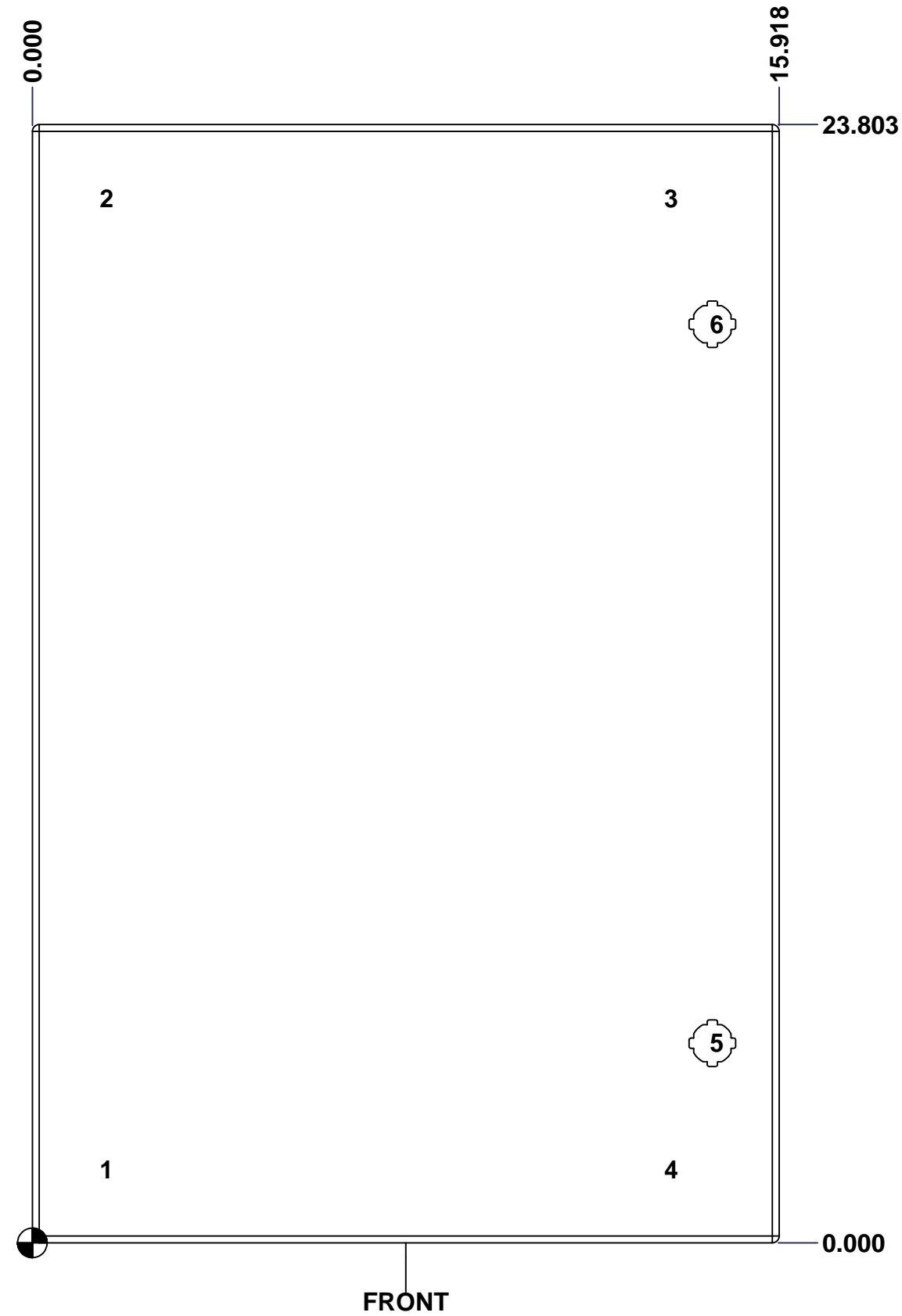

FRONT

| | | |
|--|-----------------------------|----------|
| | Description | Status |
| | 5412ESCS 24" x 16" Cover | (NULL) |
| | Part Number Numéro Pièce | Rev. |
| | 5412ESCS241606C | 0 |
| | | 2 |
| | | 3 |

This drawing is confidential and must not be reproduced or used without the consent of EXM

Ce dessin est confidentiel et ne doit pas être reproduit ou utilisé sans le consentement de EXM

| No. | Revisions | Date | By/Par |
|-----|-----------|------|--------|
| | | | |
| | | | |
| | | | |
| | | | |
| | | | |

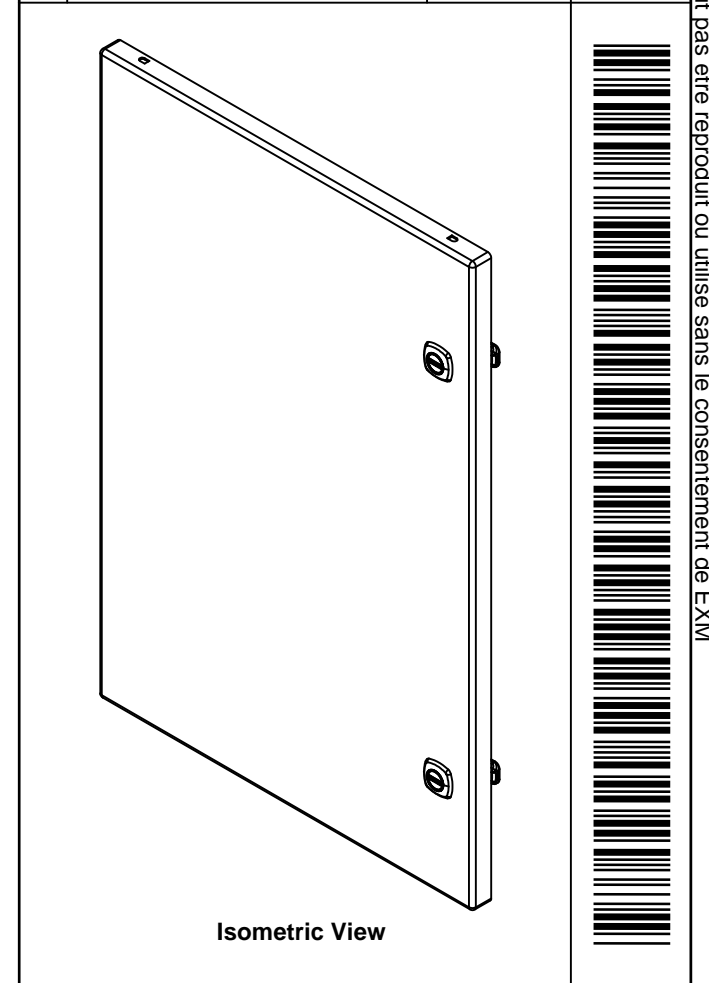

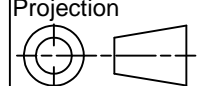
| | | |
|--|---|---|
|  Tél: (450) 979-4373 Fax: (450) 979-4626 www.exmweb.com | | Flatness Aplatissement Max 3.0mm Projection  |
| Customer Client | Date | Date 17-Feb-16 |
| Drawn By Dessiné Par | BoxCad: BoxCad | |
| Material Matière | 16 Ga Cold Rolled A1008 CS Type B (1.4mm) | |
| Color Couleur | Asa-61 Grey | Finish Fini Smooth |
| Description | 5412ESCS 24" x 16" Cover | |
| Part Number Numéro Pièce | Rev. 0 | 3 |
| 5412ESCS241606C | | |

| Qty | Part Name | Rev | Description |
|------------|-------------------|-----|---|
| 1 | STK-P-02400S | 0 | Powder Paint (Asa-61 Grey / Smooth) |
| 2 | STK-Q-46020-24 | 5 | 5412 ES Vertical Door Stiffener 24" |
| 4 | STK-Q-16055 | 1 | M6 x 18mm Stud (No Paint Cap Required) |
| 1 | 5412ESCS241606G | 0 | 5412ESCS 24" x 16" Cover Gasket Part |
| 1 | 5412ESCS241606C-P | 0 | 5412ESCS 24" x 16" Cover Part |
| 2 | STK-K-09800 | 10 | 5412 ES Hinge with 2 Captive Hinge Pins |
| 2 | 880 SCQ4-SL | 6 | 5412 ES 1/4 Turn Lock |
| 4 | STK-Q-07220 | 1 | M6 Nylon Insert Lock Nut |
| Parts List | | | |

This drawing is confidential and must not be reproduced or used without the consent of EXM

Ce dessin est confidentiel et ne doit pas être reproduit ou utilisé sans le consentement de EXM

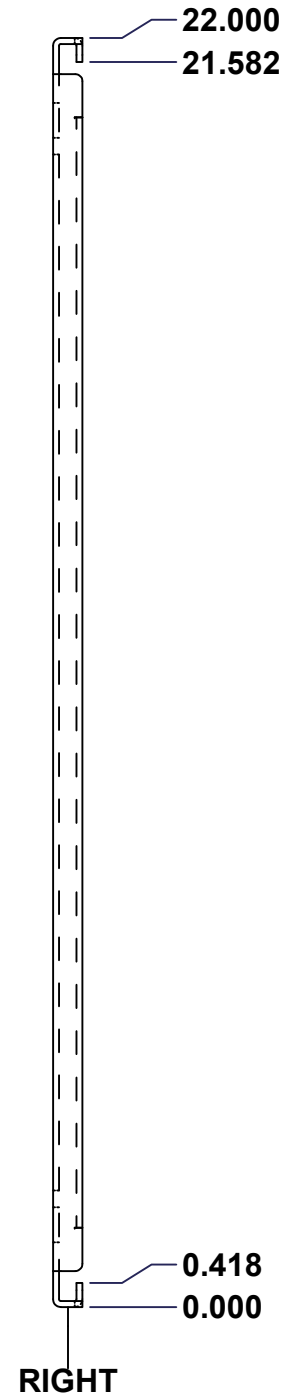
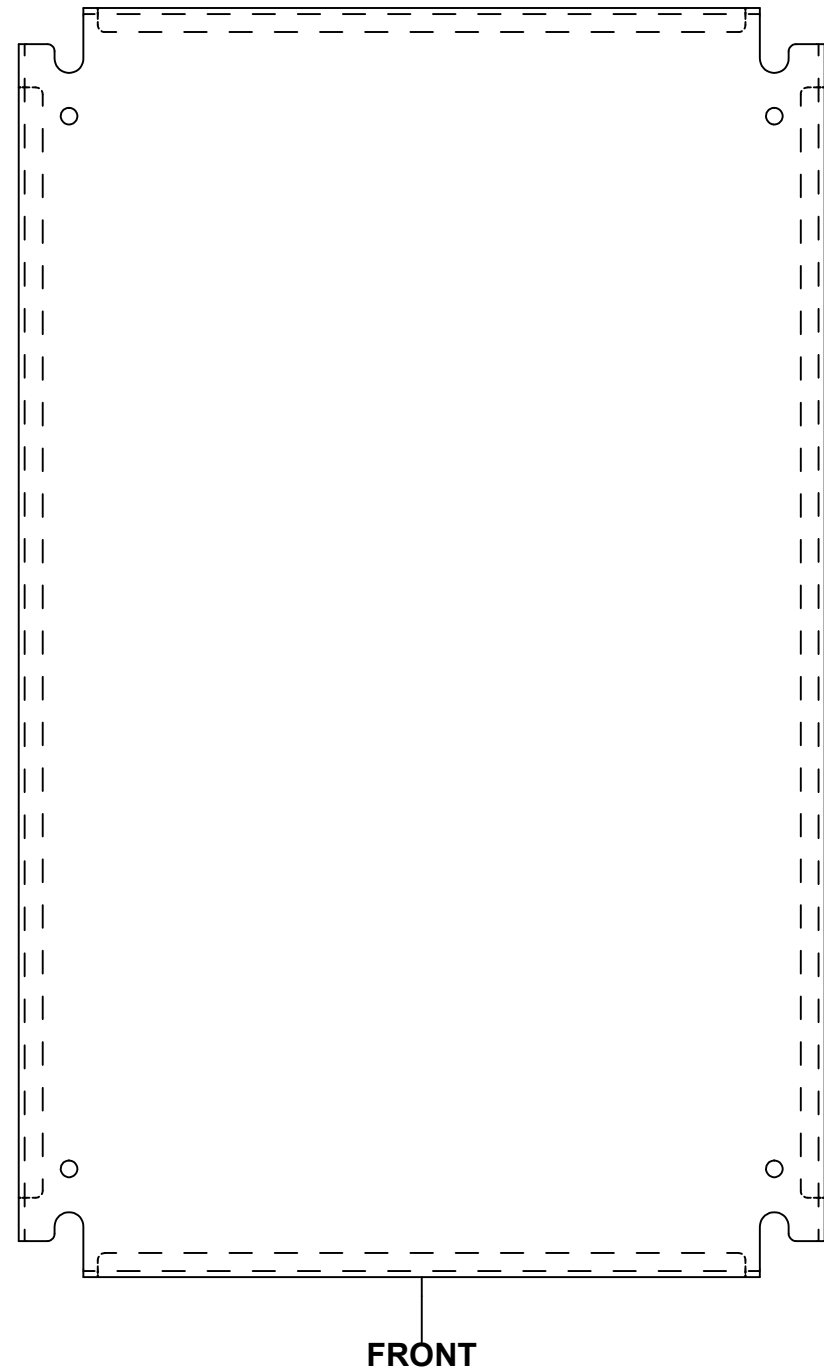
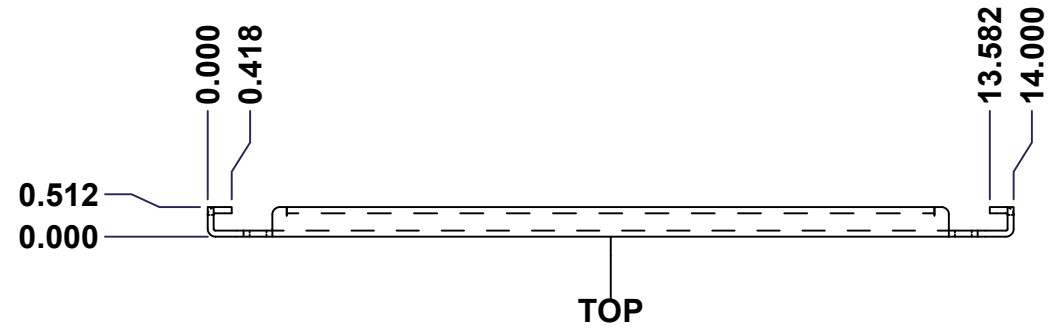

| No. | Revisions | Date | By/Par |
|-----|-----------|------|--------|
| | | | |
| | | | |
| | | | |
| | | | |
| | | | |

Isometric View

| | | |
|--|-----------------|--|
| Tél: (450) 979-4373 Fax: (450) 979-4626 www.exmweb.com | | Flatness Aplatissement Max 3.0mm Projection |
| Customer Client | Date | |
| Drawn By / Dessiné Par: BoxCad | Date: 1/23/2007 | |
| Material / Matière | See Part List | |
| Color / Couleur | See Part List | Finish / Fini: See Part List |
| Description: 881 SP - Inner Panel | | Detail Rev. |
| Part Number / Numéro Pièce: 881 SP2416G | Rev. 0 | 1/2 |

| Qty | Part Number | Rev | Description | Material | Color | Finish |
|-----|---------------|-----|---------------------------|------------------|-----------|------------|
| 1 | 881 SP2416G-P | 0 | 881 SP - Inner Panel Part | 12 Ga Galvanized | Unpainted | Galvanized |

Parts List

This drawing is confidential and must not be reproduced or used without the consent of EXM

Ce dessin est confidentiel et ne doit pas être reproduit ou utilisé sans le consentement de EXM

| Table 1 | | | FRONT VIEW |
|---------|--------|--------|--------------------------|
| CUT-OUT | XDIM | YDIM | DESCRIPTION |
| 1 | 0.875 | 1.875 | GROUND HOLE (RND Ø0.290) |
| 2 | 13.125 | 1.875 | GROUND HOLE (RND Ø0.290) |
| 3 | 0.875 | 20.125 | GROUND HOLE (RND Ø0.290) |
| 4 | 13.125 | 20.125 | GROUND HOLE (RND Ø0.290) |

All knockouts are actual size / Les disques défonçables sont grandeur réel

| No. | Revisions | Date | By/Par |
|-----|-----------|------|--------|
| | | | |
| | | | |
| | | | |
| | | | |
| | | | |

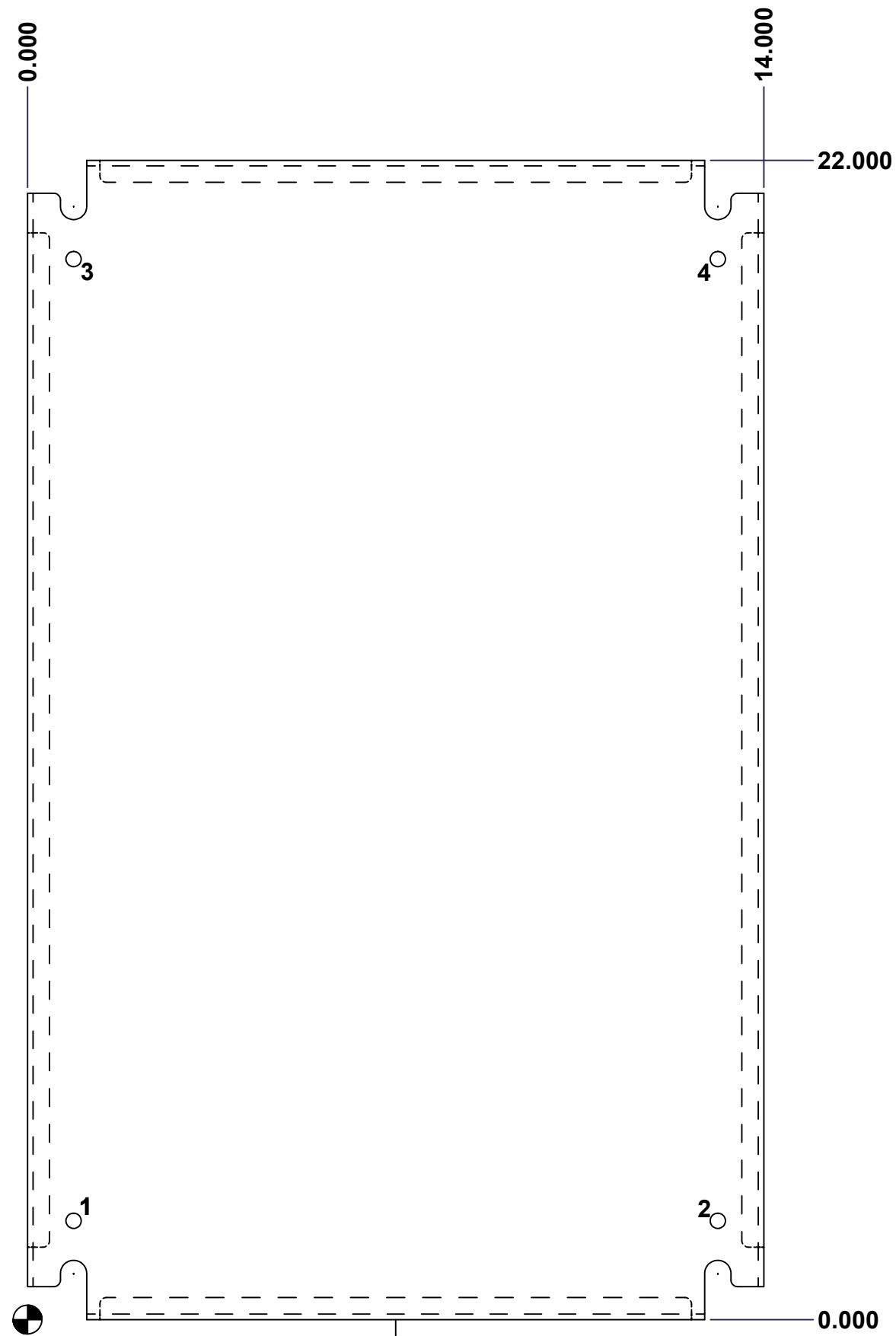

FRONT

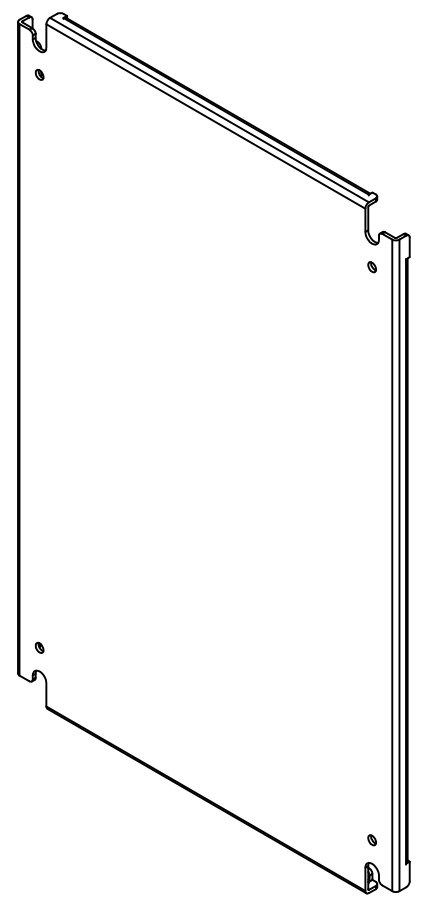

Isometric View



| | | |
|-----------------------------|--|------------------------------|
| | Tél: (450) 979-4373 Fax: (450) 979-4626 www.exmweb.com | Flatness Aplatissement |
| | | Max 3.0mm |
| Projection | | |
| Customer Client | | Date |
| Drawn By Dessiné Par | BoxCad | Date 1/23/2007 |
| Material Matière | See Part List | |
| Color Couleur | See Part List | Finish Fini See Part List |
| Description | | Detail Rev. |
| 881 SP - Inner Panel | | |
| Part Number Numéro Pièce | 881 SP2416G | Rev. 2 |
| | | 0 |