

This drawing is confidential and must not be reproduced or used without the consent of EXM

Ce dessin est confidentiel et ne doit pas être reproduit ou utilisé sans le consentement de EXM

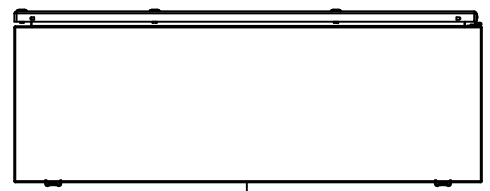

TOP

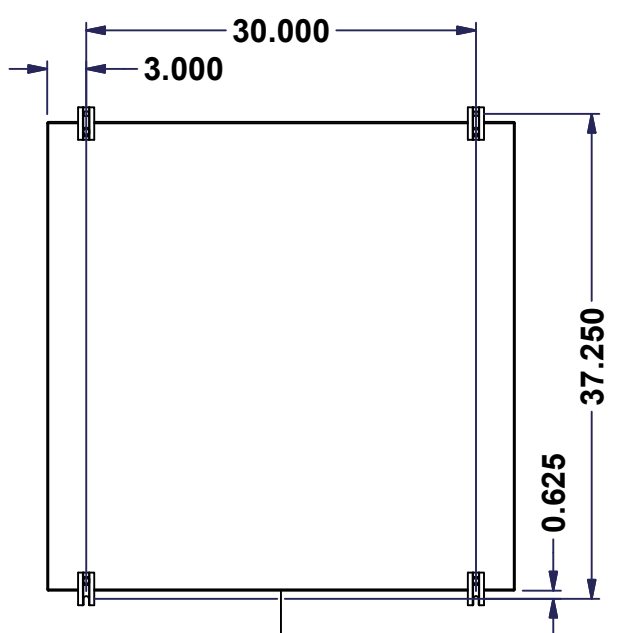

BACK

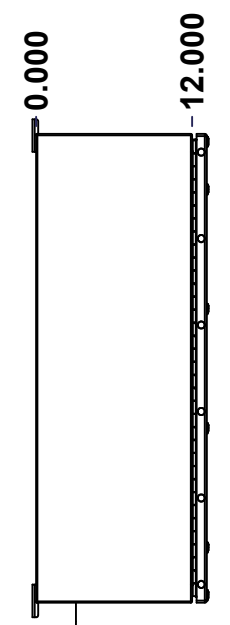

LEFT

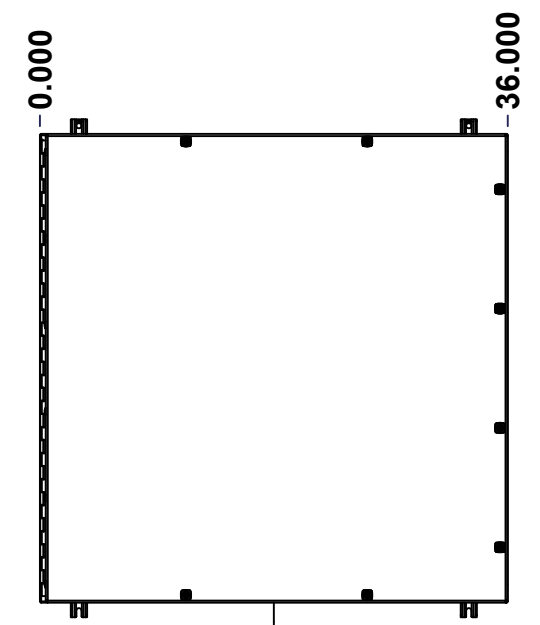

FRONT

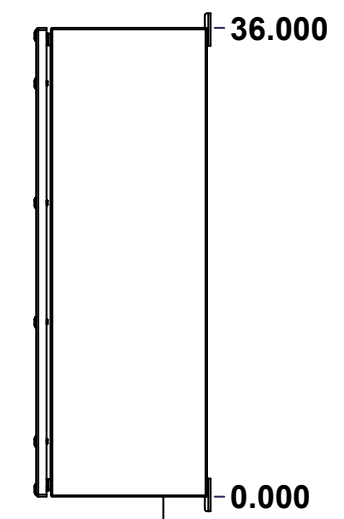

RIGHT



BOTTOM

No.	Revisions	Date	By/Par

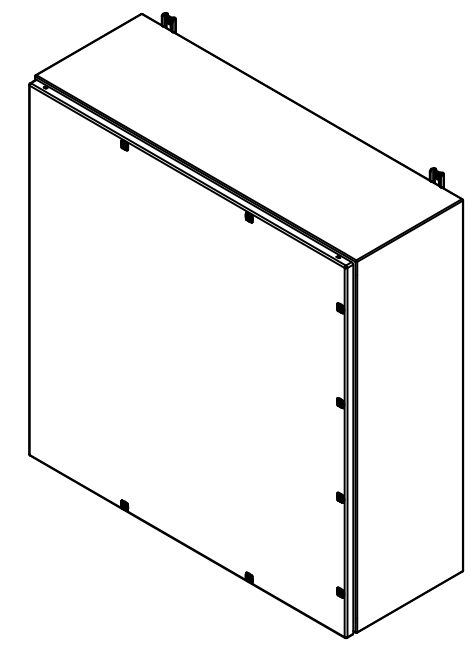

Isometric View

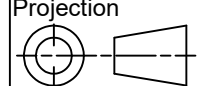

 Tél: (450) 979-4373 Fax: (450) 979-4626 <a href="http://www.exmweb.com">www.exmweb.com</a>	Flatness Aplatissement Max 3.0mm
	Projection 
Customer Client	Date
Drawn By / Dessiné Par: BoxCad: BoxCad	Date: 14-Jan-22
Material / Matière: 14 Ga Cold Rolled A1008 CS Type B (1.7mm)	
Color / Couleur: Asa-61 Grey	Finish / Fini: Smooth
Description: 5412ESEL 36" x 36" x 12" Assembly	Detail Rev.
Part Number / Numéro Pièce: <b>5412ESEL363612</b>	Rev. 1 0

SEE BILL OF MATERIAL ON LAST PAGE

2

This drawing is confidential and must not be reproduced or used without the consent of EXM

Ce dessin est confidentiel et ne doit pas être reproduit ou utilisé sans le consentement de EXM

NOTE	
ITEM	DESCRIPTION
1	NEMA 4/12 Enclosure
2	C/W Standard ground studs on box and cover
3	W/O Standard door stiffener
4	C/W Standard inner panel (Included)
5	C/W Standard inner panel mounting studs
6	C/W 885 ESMF1_OPEN Sold separately (Kit)
7	C/W 885 ESMF1_CLOSE Sold separately (Kit)

No.	Revisions	Date	By/Par

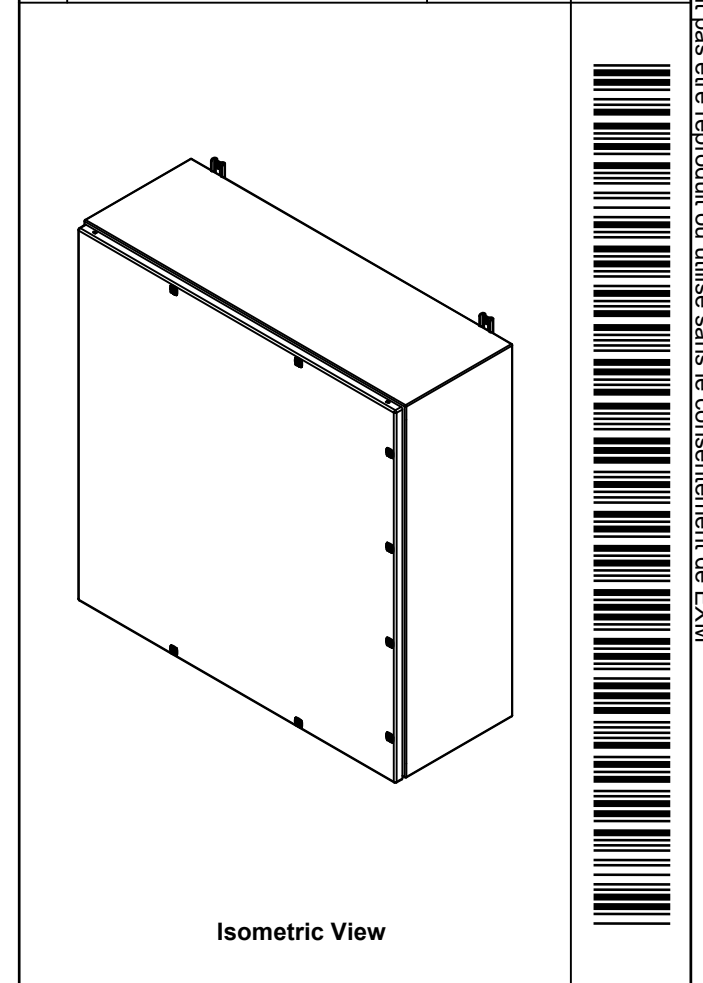

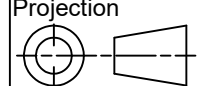
 Tél: (450) 979-4373 Fax: (450) 979-4626 <a href="http://www.exmweb.com">www.exmweb.com</a>		Flatness Aplatissement Max 3.0mm Projection 
Customer Client	Date	Date
Drawn By Dessiné Par	BoxCad: BoxCad	14-Jan-22
Material Matière	14 Ga Cold Rolled A1008 CS Type B (1.7mm)	
Color Couleur	Asa-61 Grey	Finish Fini: Smooth
Description	5412ESEL 36" x 36" x 12" Assembly	
Part Number Numéro Pièce	5412ESEL363612	Rev. 0

Qty	Part Number	Rev	Description
1	880 PP	6	Self Adhesive Print Pocket
1	STK-K-01800	5	5412 ES Accessory Kit
8	STK-Q-07310	2	Flange Lock Nut M8
1	885SP3636G	0	885SP 36" x 36" Inner Panel Part
8	STK-Q-07610	8	M8 Plastic Spacer 22.2mm
6	STK-Q-04050-14	5	M6 x 14mm Hexagon Socket Head Machine Screw with Nyseal
6	RIVET_NUT_M6_FH_CE	0	Rivet Nut M6 (Low Profile Close End)
1	5412ESEL363612C	0	5412ESEL 36" x 36" Cover
1	5412ESEL363612B	0	5412ESEL 36" x 36" x 12" Body
Parts List			

PACKING		
ITEM	QTY	DESCRIPTION
Cardboard sleeve	2	Top and Bottom
Cardboard strip	2	Between back of enclosure and inner panel
Plastic bag	1	To protect cover surface and inside gasket
Plastic strap - Black	2	To Squeeze the 2 cardboard sleeve together
Packaging label	1	White label with product number

This drawing is confidential and must not be reproduced or used without the consent of EXM

Ce dessin est confidentiel et ne doit pas être reproduit ou utilisé sans le consentement de EXM

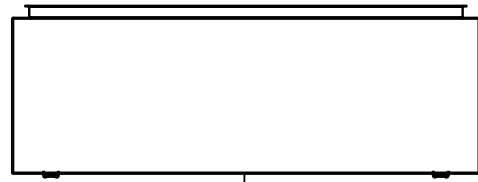

TOP

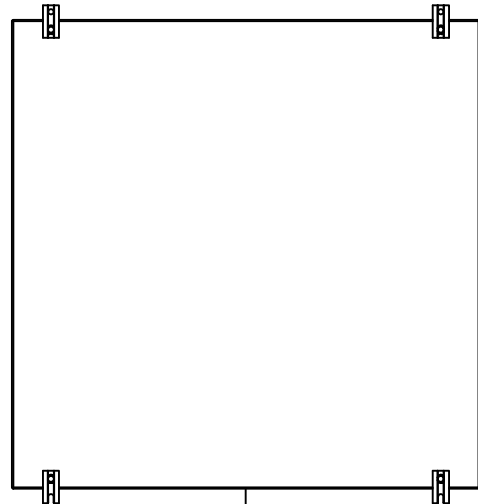

BACK

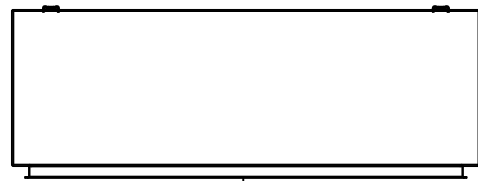

BOTTOM

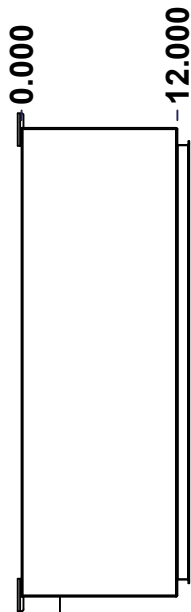

LEFT

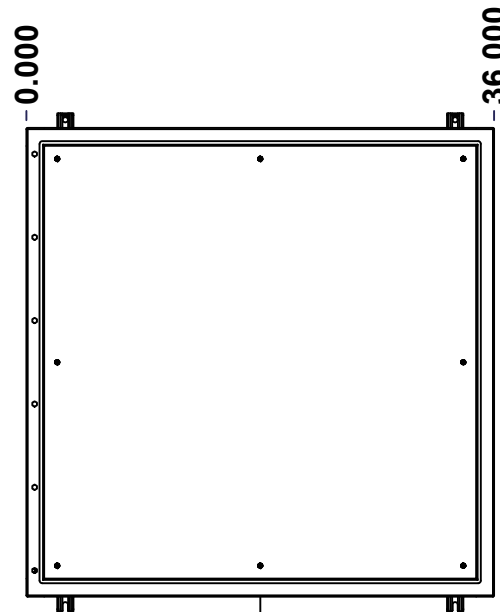

FRONT

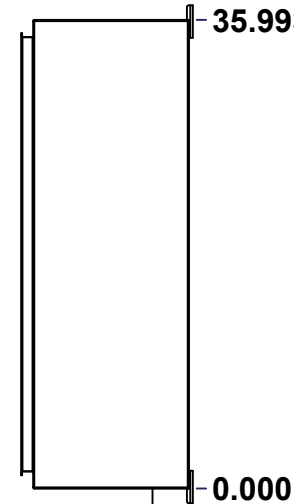

RIGHT

No.	Revisions	Date	By/Par

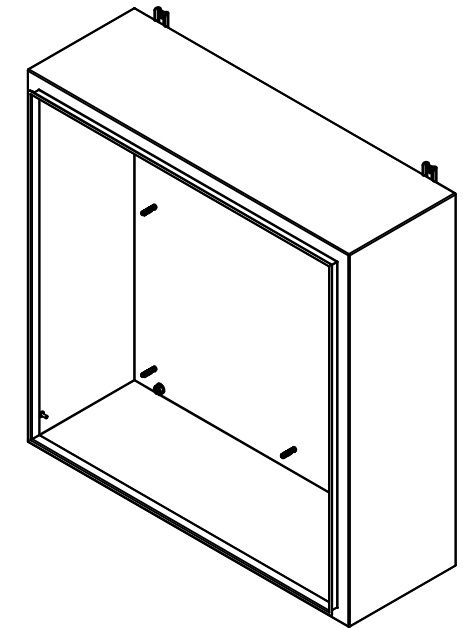

Isometric View



Tél: (450) 979-4373  
 Fax: (450) 979-4626  
[www.exmweb.com](http://www.exmweb.com)

Flatness  
Aplatissement

Max 3.0mm

Projection



Customer Client	Date
Drawn By / Dessiné Par: BoxCad: BoxCad	Date: 14-Jan-22
Material / Matière: 14 Ga Cold Rolled A1008 CS Type B (1.7mm)	
Color / Couleur: Asa-61 Grey	Finish / Fini: Smooth
Description: 5412ESEL 36" x 36" x 12" Body	Detail Rev.
Part Number / Numéro Pièce: 5412ESEL363612B	Rev. 0

SEE BILL OF MATERIAL ON LAST PAGE

1 / 7

This drawing is confidential and must not be reproduced or used without the consent of EXM

Ce dessin est confidentiel et ne doit pas être reproduit ou utilisé sans le consentement de EXM

<b>STANDARD FEATURES ARE NOT LISTED IN THIS HOLE TABLE</b>			
<b>HOLE TABLE - LEFT VIEW (CUSTOM FEATURE ONLY)</b>			
CUT-OUT	XDIM	YDIM	DESCRIPTION
1	10.500	2.000	GND STUD M6 x 16mm (Inside)

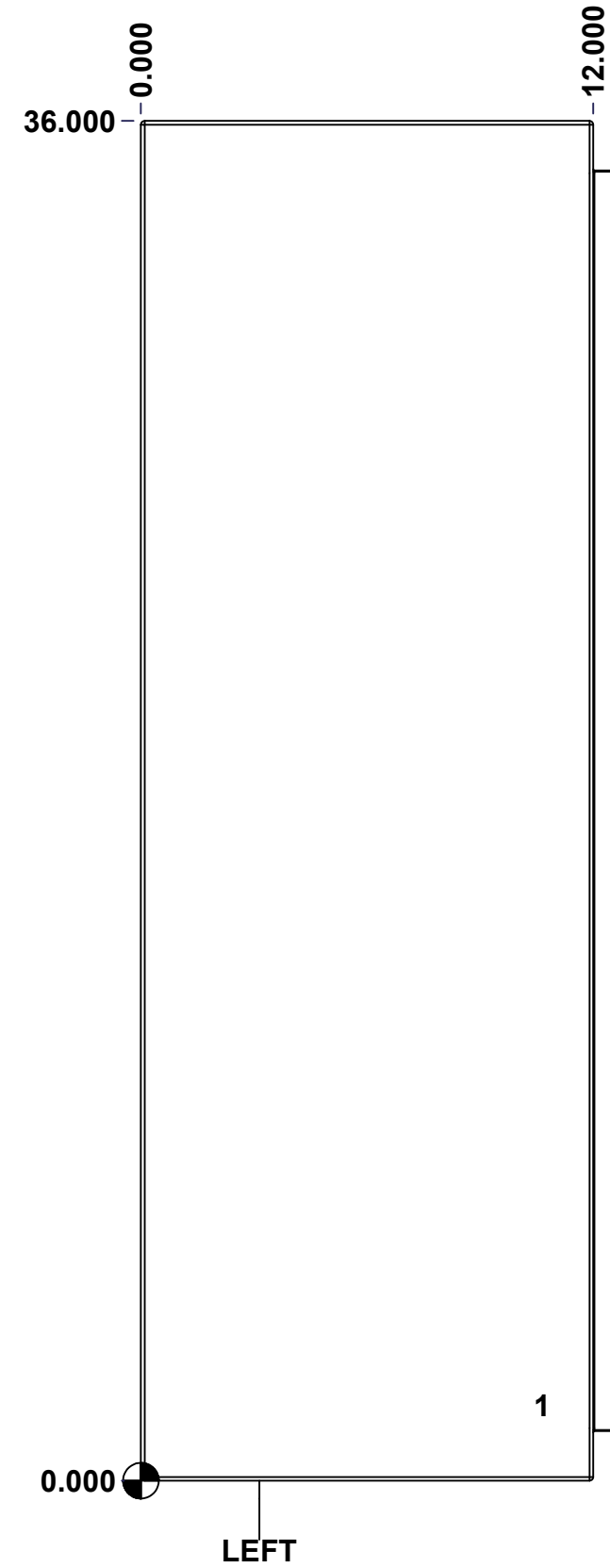

	Description		Status	
	5412ESEL 36" x 36" x 12" Body			
	Part Number Numéro Pièce		Rev.	
	<b>5412ESEL363612B</b>		<b>0</b>	5 / 7

This drawing is confidential and must not be reproduced or used without the consent of EXM

Ce dessin est confidentiel et ne doit pas être reproduit ou utilisé sans le consentement de EXM

**STANDARD FEATURES ARE NOT LISTED IN THIS HOLE TABLE**

**HOLE TABLE - BACK VIEW (CUSTOM FEATURE ONLY)**

CUT-OUT	XDIM	YDIM	DESCRIPTION
1	2.375	2.375	IP STUD M8 x 35mm (Inside)
2	2.375	33.625	IP STUD M8 x 35mm (Inside)
3	33.625	33.625	IP STUD M8 x 35mm (Inside)
4	33.625	2.375	IP STUD M8 x 35mm (Inside)
5	2.375	18.000	IP STUD M8 x 35mm (Inside)
6	33.625	18.000	IP STUD M8 x 35mm (Inside)
7	18.000	2.375	IP STUD M8 x 35mm (Inside)
8	18.000	33.625	IP STUD M8 x 35mm (Inside)
-----			
9	33.000	0.000	FOOT 885 ESMF1_OPEN
10	3.000	0.000	FOOT 885 ESMF1_OPEN
11	33.000	36.000	FOOT 885 ESMF1_CLOSE
12	3.000	36.000	FOOT 885 ESMF1_CLOSE

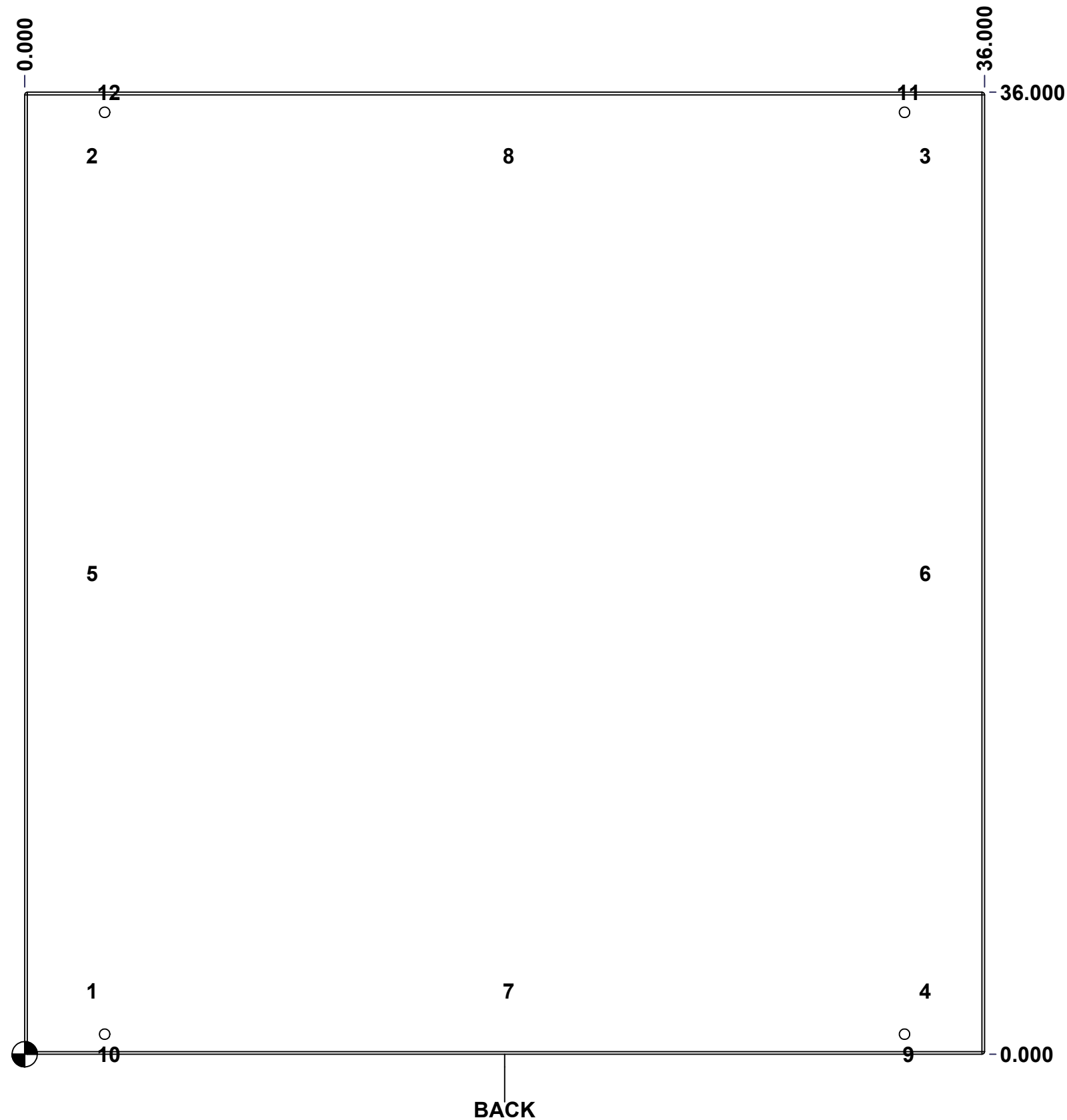

	Description		Status
	5412ESEL 36" x 36" x 12" Body		
	Part Number Numéro Pièce		Rev.
	5412ESEL363612B		0
			6
			7

This drawing is confidential and must not be reproduced or used without the consent of EXM

Ce dessin est confidentiel et ne doit pas être reproduit ou utilisé sans le consentement de EXM

No.	Revisions	Date	By/Par

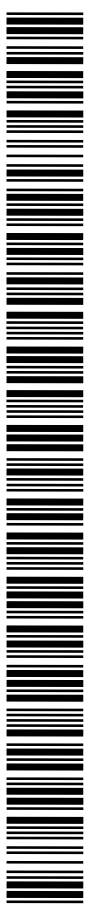
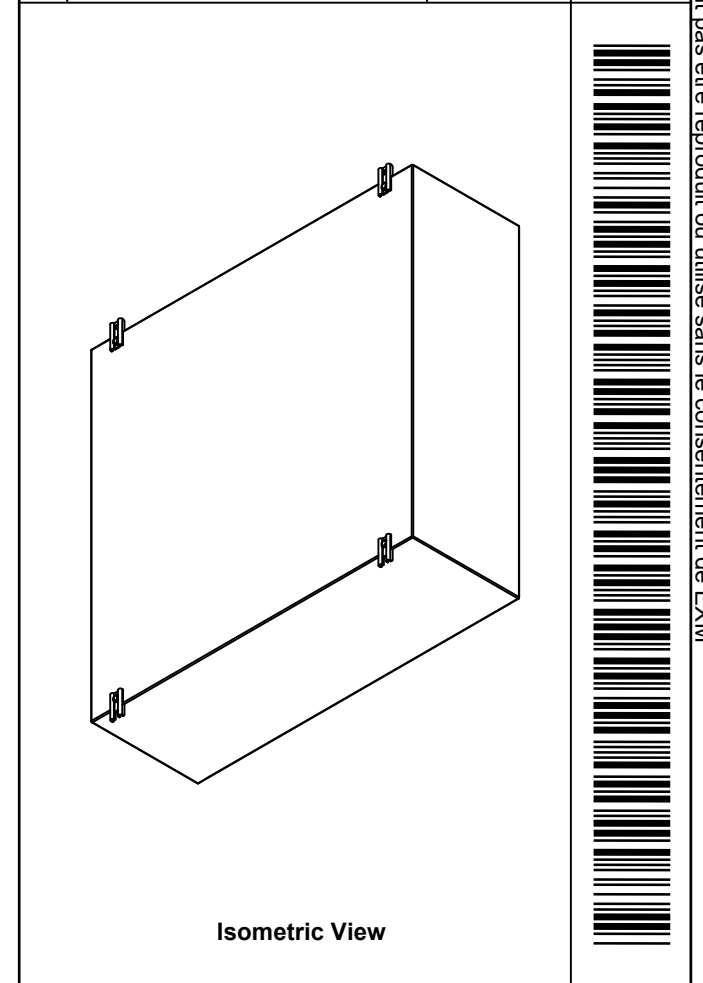

Tél: (450) 979-4373 Fax: (450) 979-4626 <a href="http://www.exmweb.com">www.exmweb.com</a>		Flatness Aplatissement	
		Max 3.0mm Projection	
Customer Client		Date	
Drawn By Dessiné Par BoxCad: BoxCad		Date 14-Jan-22	
Material Matière 14 Ga Cold Rolled A1008 CS Type B (1.7mm)			
Color Couleur Asa-61 Grey		Finish Fini Smooth	
Description 5412ESEL 36" x 36" x 12" Body			Detail Rev.
Part Number Numéro Pièce		Rev.	7
<b>5412ESEL363612B</b>		<b>0</b>	7

Qty	Part Number	Rev	Description
1	STK-P-02400S	0	Powder Paint (Asa-61 Grey / Smooth)
1	STK-Q-16080	0	Ground Stud M6 x 16mm
8	STK-Q-16005	1	Stud M8 x 35 (No Paint Cap Required)
1	5412ESEL363612B-P	0	5412ESEL 36" x 36" x 12" Body Part
2	885 ESMF1_CLOSE	0	885 ESMF1 Mounting Foot (Closed Hole)
2	885 ESMF1_OPEN	0	885 ESMF1 Mounting Foot (Opened Hole)
Parts List			

This drawing is confidential and must not be reproduced or used without the consent of EXM

Ce dessin est confidentiel et ne doit pas être reproduit ou utilisé sans le consentement de EXM

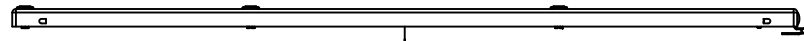

TOP

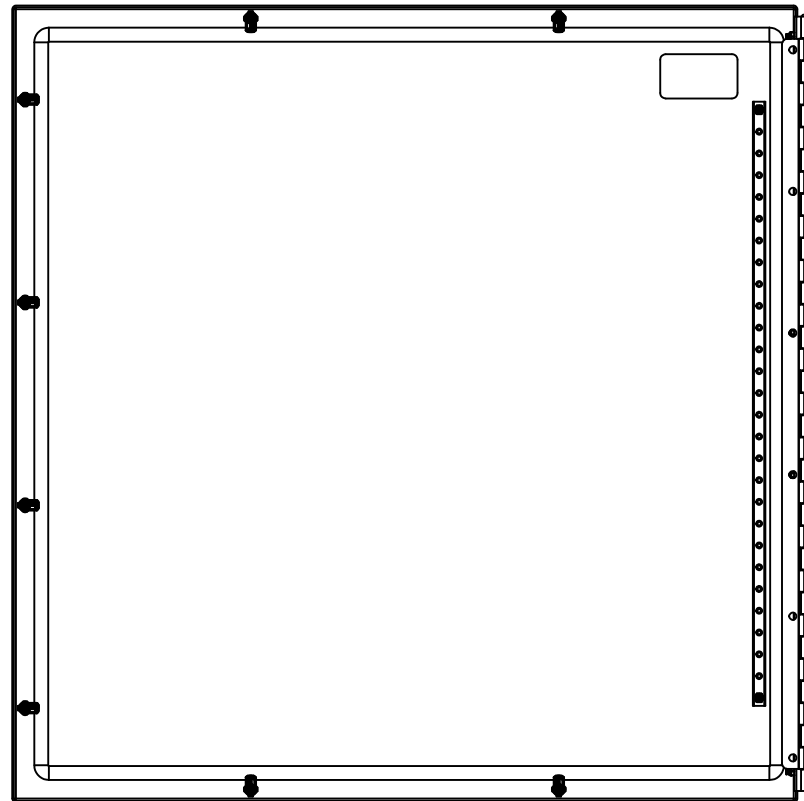

BACK

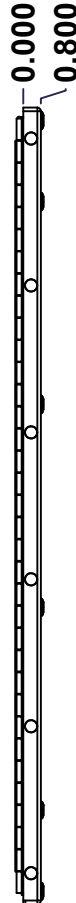

LEFT

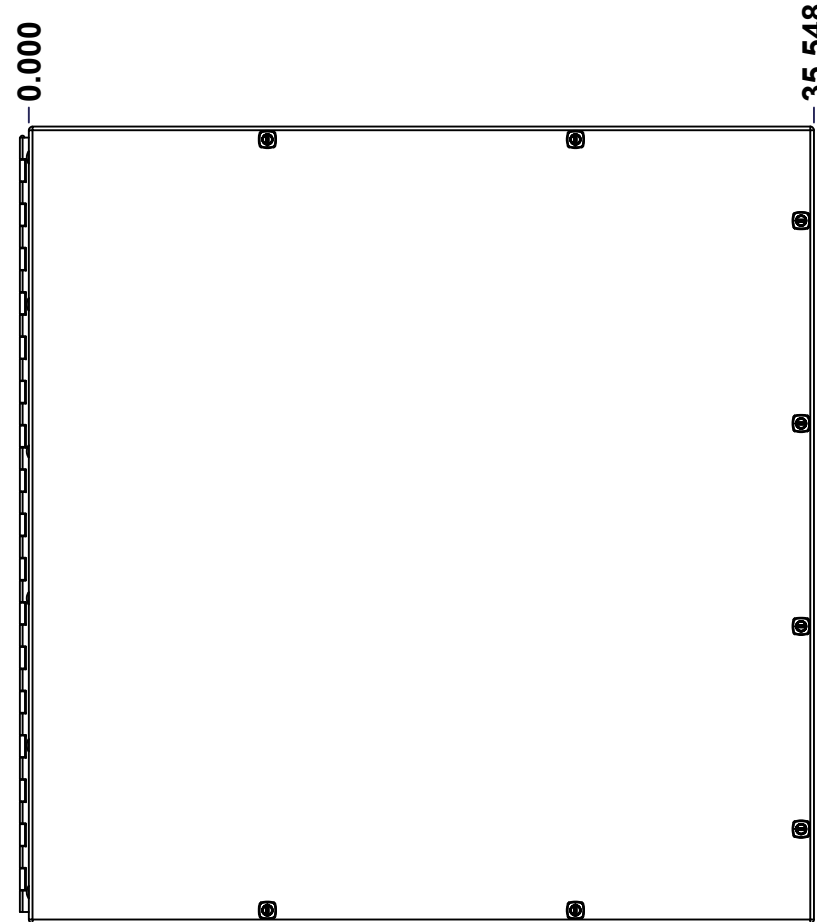

FRONT

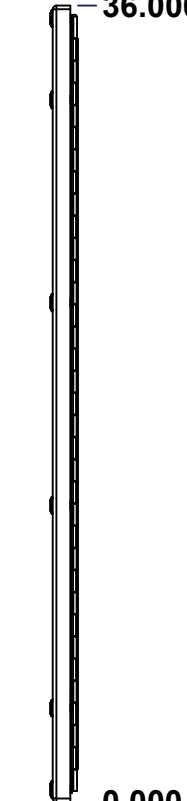

RIGHT

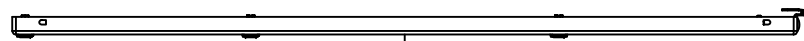

BOTTOM

No.	Revisions	Date	By/Par

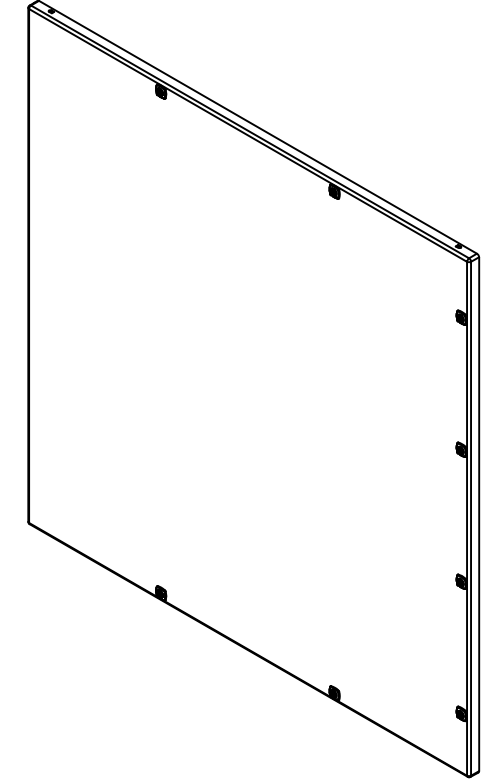

Isometric View



Tél: (450) 979-4373  
 Fax: (450) 979-4626  
[www.exmweb.com](http://www.exmweb.com)

Flatness  
Aplatissement  
Max 3.0mm  
Projection

Customer Client	Date
Drawn By / Dessiné Par: BoxCad: BoxCad	Date: 14-Jan-22
Material / Matière: 14 Ga Cold Rolled A1008 CS Type B (1.7mm)	
Color / Couleur: Asa-61 Grey	Finish / Fini: Smooth
Description: 5412ESEL 36" x 36" Cover	Detail Rev.

SEE BILL OF MATERIAL ON LAST PAGE

Part Number / Numéro Pièce: <b>5412ESEL363612C</b>	Rev. <b>0</b>	1 / 3
--	---------------	-------

This drawing is confidential and must not be reproduced or used without the consent of EXM

Ce dessin est confidentiel et ne doit pas être reproduit ou utilisé sans le consentement de EXM

**STANDARD FEATURES ARE NOT LISTED IN THIS HOLE TABLE**

**HOLE TABLE - FRONT VIEW (CUSTOM FEATURE ONLY)**

CUT-OUT	XDIM	YDIM	DESCRIPTION
1	2.122	4.713	STUD M6 x 18mm (Inside)
2	2.122	31.287	STUD M6 x 18mm (Inside)
-----			
3	4.458	32.803	LABEL_EXM (Inside)
4	34.969	31.750	LOCK 880 SCQ5-SL @ 180.0°
5	34.969	13.417	LOCK 880 SCQ5-SL @ 180.0°
6	34.969	22.583	LOCK 880 SCQ5-SL @ 180.0°
7	10.800	35.420	LOCK 880 SCQ5-SL @ 270.0°
8	24.749	35.420	LOCK 880 SCQ5-SL @ 270.0°
9	10.800	0.580	LOCK 880 SCQ5-SL @ 90.0°
10	24.749	0.580	LOCK 880 SCQ5-SL @ 90.0°
11	34.969	4.250	LOCK 880 SCQ5-SL @ 180.0°

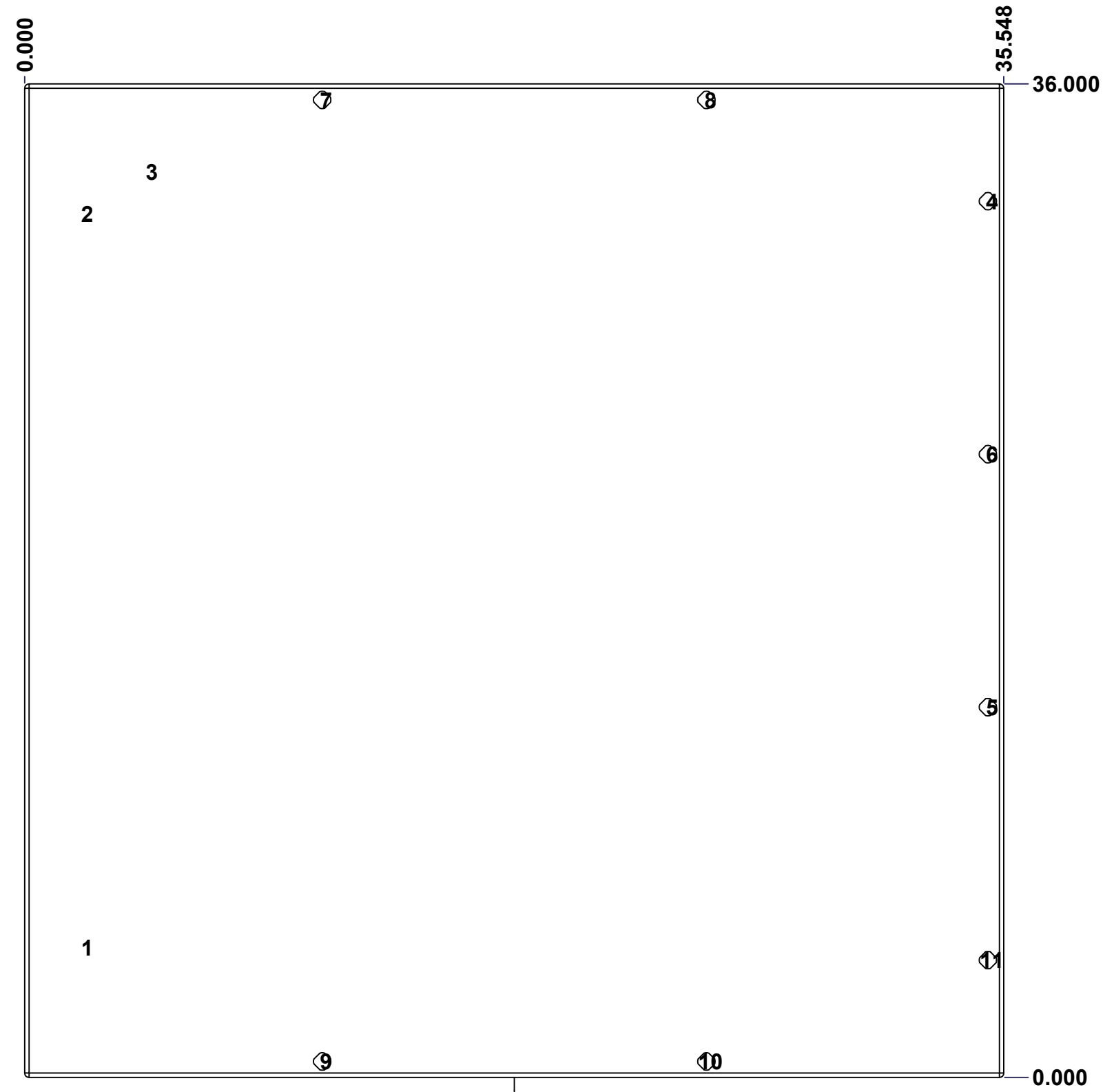

FRONT

	Description	Status	
	5412ESEL 36" x 36" Cover	(NULL)	
	Part Number Numéro Pièce	Rev.	
	<b>5412ESEL363612C</b>	<b>0</b>	2 3



This drawing is confidential and must not be reproduced or used without the consent of EXM

Ce dessin est confidentiel et ne doit pas être reproduit ou utilisé sans le consentement de EXM

No.	Revisions	Date	By/Par

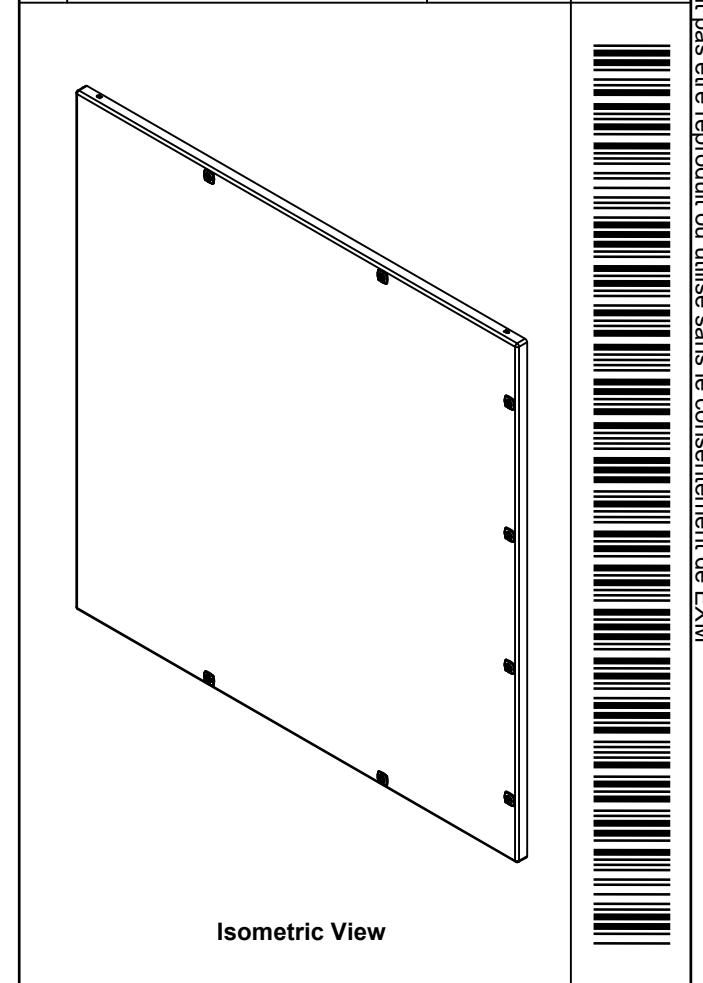

1	STK-Q-46020-30	5	5412 ES Vertical Door Stiffener 30"
2	STK-Q-16055	1	M6 x 18mm Stud (No Paint Cap Required)
6	STK-Q-07225	0	M6 Stainless Steel Nylon Insert Lock Nut
1	5412ESEL363612HP-P	0	Piano Hinge Pin (Length= 35.182")
8	STK-A-79955	2	5412 ESEL Plastic Clip-in 1/4 Turn Lock
1	STK-S-00100	0	3.5" x 2" Silver Milar Flexcon Sticker
1	STK-P-02400S	0	Powder Paint (Asa-61 Grey / Smooth)
1	5412ESEL363612H1-P	0	5412ESEL 36" x 36" Piano Hinge Part
1	5412ESEL363612H2-P	0	5412ESEL 36" x 36" Piano Hinge Part
6	STK-Q-00260	1	M6 x 13mm Carriage Bolt
1	5412ESEL363612G	0	5412ESEL 36" x 36" Cover Gasket Part
1	5412ESEL363612C-P	0	5412ESEL 36" x 36" Cover Part
2	STK-Q-07220	1	M6 Nylon Insert Lock Nut
Qty	Part Name	Rev	Description
Parts List			

<p>Tél: (450) 979-4373 Fax: (450) 979-4626 <a href="http://www.exmweb.com">www.exmweb.com</a></p>	Flatness Aplatissement	<p>Max 3.0mm</p>
	Projection	
Customer Client	Date	
Drawn By Dessiné Par	BoxCad: BoxCad	Date 14-Jan-22
Material Matière	14 Ga Cold Rolled A1008 CS Type B (1.7mm)	
Color Couleur	Asa-61 Grey	Finish Fini Smooth
Description	5412ESEL 36" x 36" Cover	
Part Number Numéro Pièce	Rev. 0	3
<b>5412ESEL363612C</b>		3

This drawing is confidential and must not be reproduced or used without the consent of EXM

Ce dessin est confidentiel et ne doit pas être reproduit ou utilisé sans le consentement de EXM

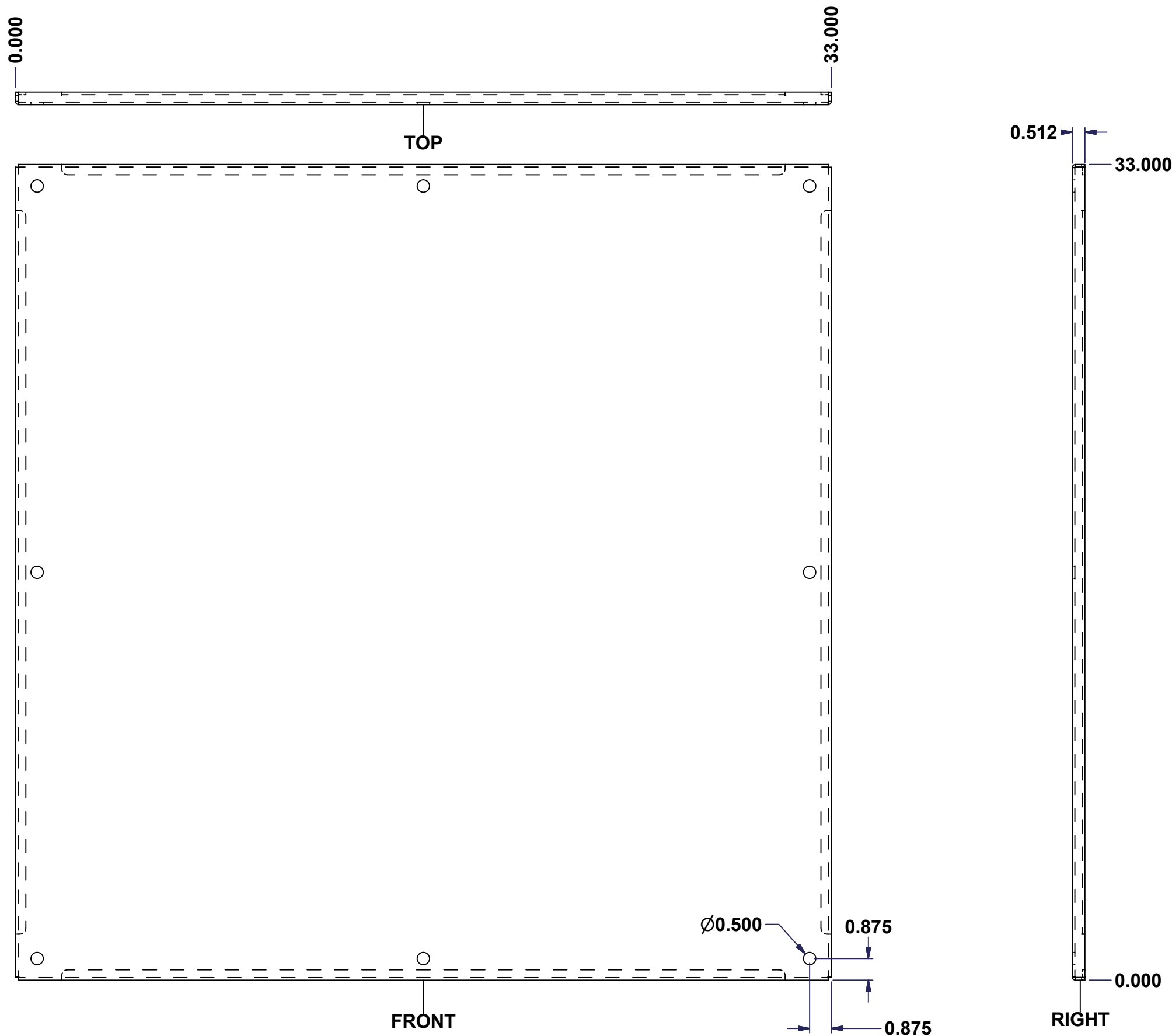

No.	Revisions	Date	By/Par

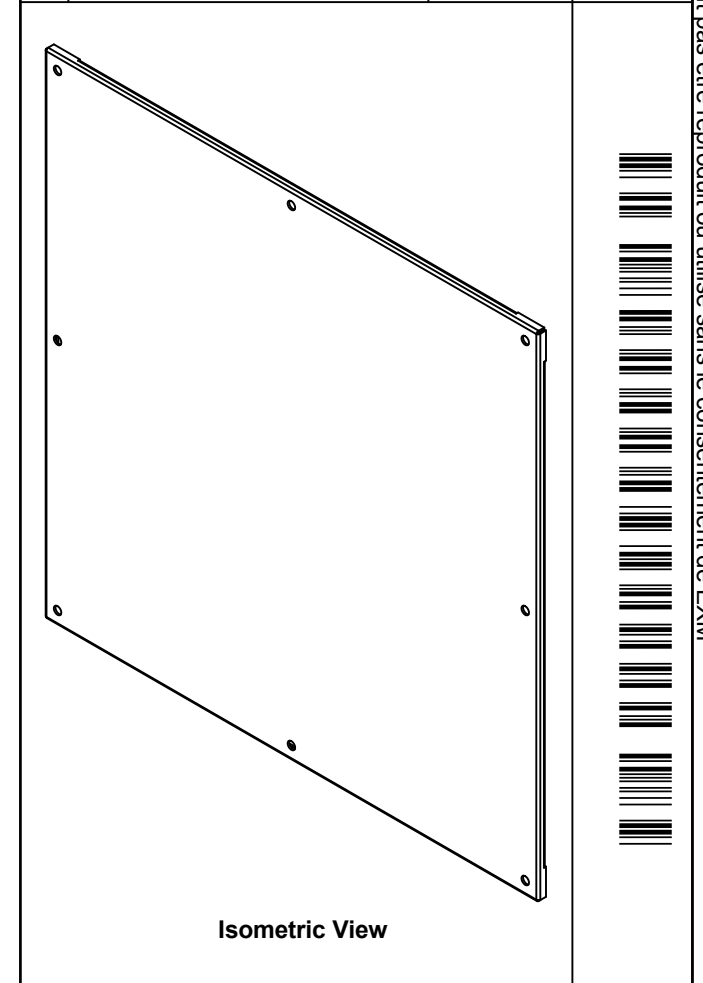

Tél: (450) 979-4373 Fax: (450) 979-4626 <a href="http://www.exmweb.com">www.exmweb.com</a>		Flatness Aplatissement Max 3.0mm Projection 
Customer Client	Date	
Drawn By / Dessiné Par: BoxCad: nickz	Date: 01/03/2017	
Material / Matière: 12 Ga Galvanized (2.5mm)	Finish / Fini: See Part List	
Description: 885SP 36" x 36" Inner Panel Part		Detail Rev.
Part Number / Numéro Pièce: <b>885SP3636G</b>	Rev.:	1

Qty	Part Number	Rev	Description	Material	Color	Finish
1	885SP3636G-P	0	885SP 36" x 36" Inner Panel Part	12 Ga Galvanized (2.5mm)	Unpainted	Galvanized

Parts List