

This drawing is confidential and must not be reproduced or used without the consent of EXM

Ce dessin est confidentiel et ne doit pas être reproduit ou utilisé sans le consentement de EXM

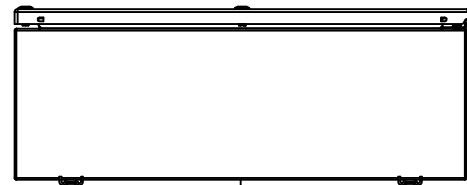

TOP

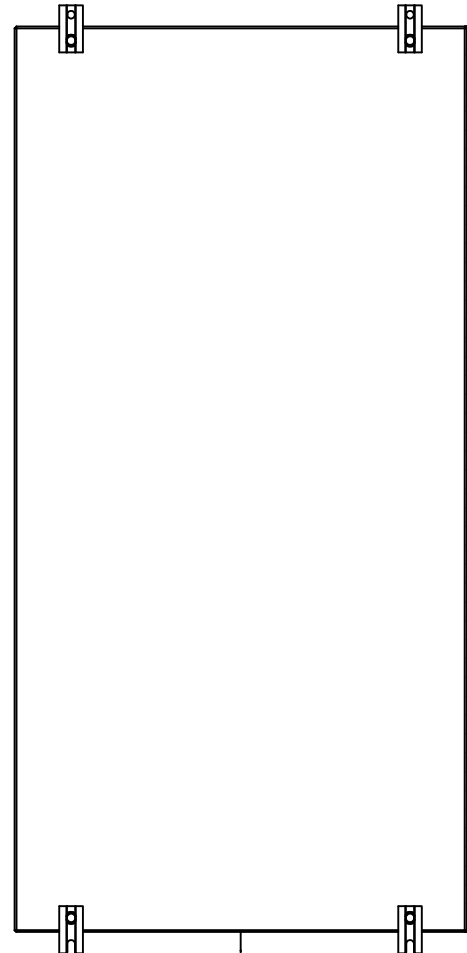

BACK

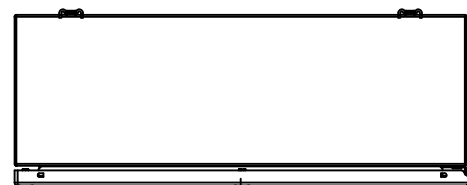

BOTTOM

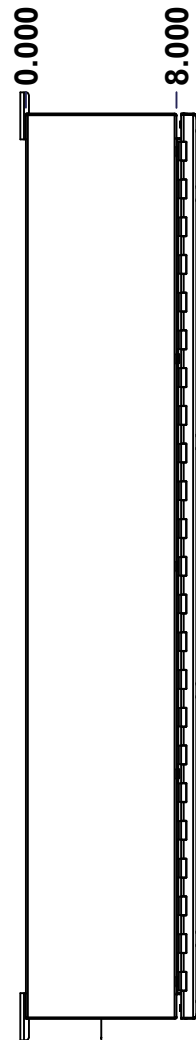

LEFT

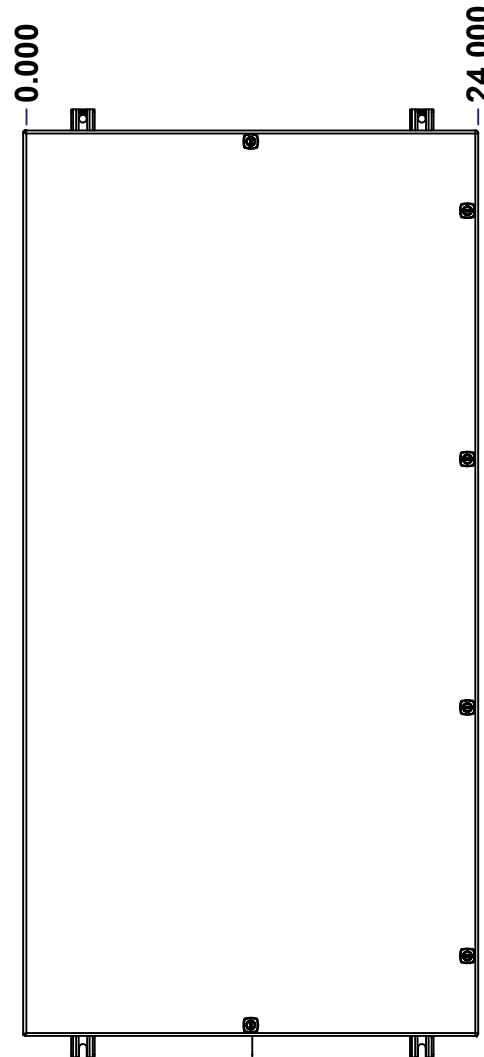

FRONT

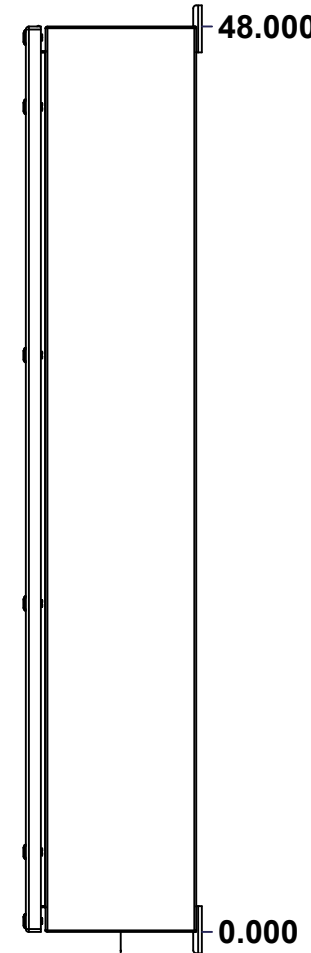

RIGHT

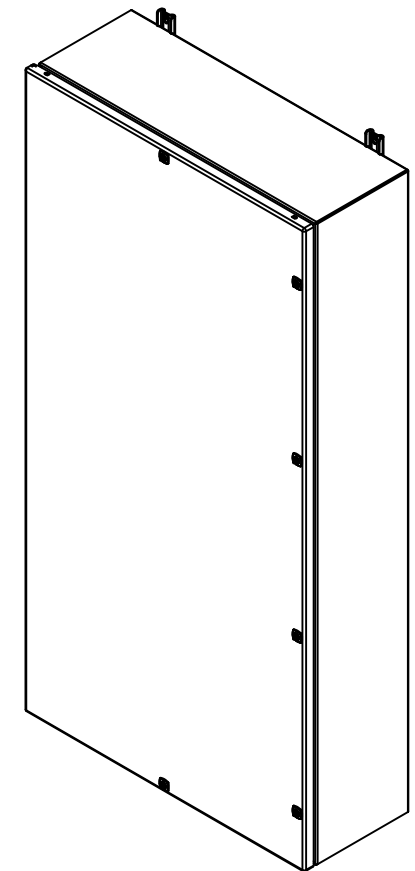

Isometric View

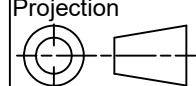

No.	Revisions	Date	By/Par

 Tél: (450) 979-4373 Fax: (450) 979-4626 www.exmweb.com		Flatness Aplatissement Max 3.0mm Projection 
Customer Client	Date	
Drawn By Dessiné Par	BoxCad: BoxCad	Date 20-Mar-20
Material Matière	14 Ga H.R.P. & O. (1.7mm)	
Color Couleur	Asa-61 Grey	Finish Fini Smooth
Description	Detail Rev.	
5412ESEL 48" x 24" x 8" Assembly		
Part Number Numéro Pièce	Rev.	1
5412ESEL482408	0	2

SEE BILL OF MATERIAL ON LAST PAGE

This drawing is confidential and must not be reproduced or used without the consent of EXM

Ce dessin est confidentiel et ne doit pas être reproduit ou utilisé sans le consentement de EXM

NOTE	
ITEM	DESCRIPTION
1	NEMA 4/12 Enclosure
2	C/W Standard ground studs on box and cover
3	W/O Standard door stiffener
4	C/W Standard inner panel (Sold separately)
5	C/W Standard inner panel mounting studs
6	C/W 885 ESMF1_CLOSE Sold separately (Kit)
7	C/W 885 ESMF1_OPEN Sold separately (Kit)

No.	Revisions	Date	By/Par

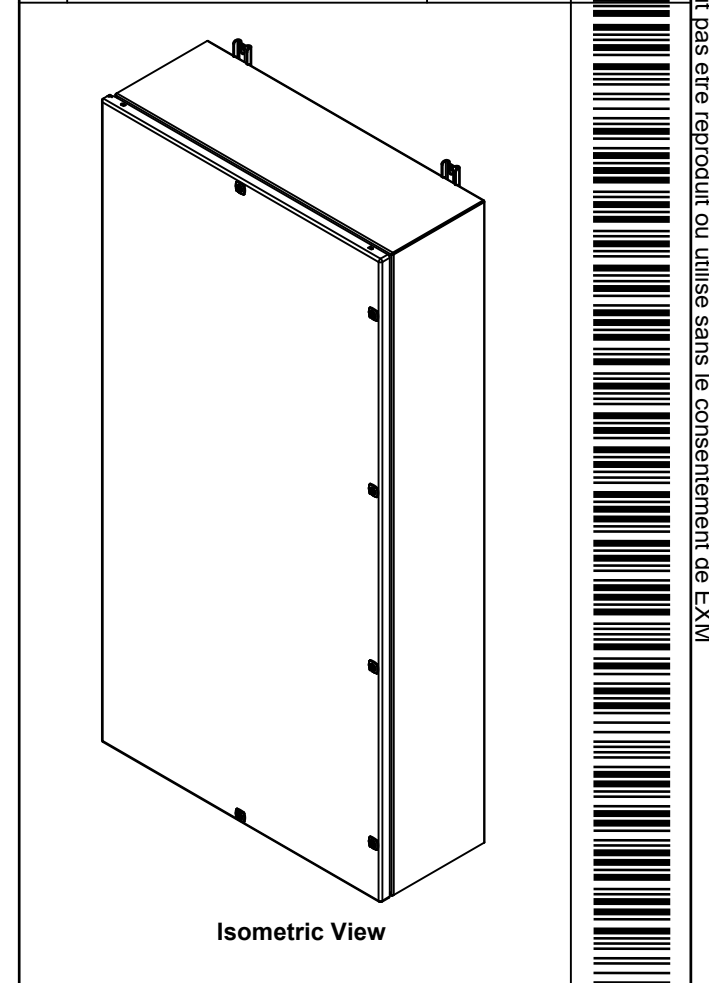

PACKING		
ITEM	QTY	DESCRIPTION
Cardboard sleeve	2	Top and Bottom
Cardboard strip	2	Between back of enclosure and inner panel
Plastic bag	1	To protect cover surface and inside gasket
Cardboard corner	4	To reinforced for the plastic strap tightening
Plastic strap - Black	2	To Squeeze 2 cardboard sleeve together
Packaging label	3	White label with PN
Plastic strap- Green	2	To secure the enclosure to the wood pallet
Wood Pallet	1	2" deeper and 3" larger than enclosure size

Qty	Part Number	Rev	Description
1	880 PP	6	Self Adhesive Print Pocket
1	STK-K-01800	5	5412 ES Accessory Kit
1	885SP4824G	0	885SP 48" x 24" Inner Panel Part
1	MCC_5412ESEL482408C	0	5412ESEL 48" x 24" Cover
6	STK-Q-07310	2	Flange Lock Nut M8
6	STK-Q-07610	8	M8 Plastic Spacer 22.2mm
1	MCC_5412ESEL482408B	0	5412ESEL 48" x 24" x 8" Body
5	STK-Q-04050-10	8	M6 x 10mm Hexagon Socket Head Machine Screw with Nyseal
Parts List			

		Tél: (450) 979-4373 Fax: (450) 979-4626 www.exmweb.com		Flatness Aplatissement Max 3.0mm
Customer Client		Date		
Drawn By Dessiné Par BoxCad: BoxCad		Date 20-Mar-20		
Material Matière		14 Ga H.R.P. & O. (1.7mm)		
Color Couleur		Asa-61 Grey	Finish Fini Smooth	
Description 5412ESEL 48" x 24" x 8" Assembly				Detail Rev.
Part Number Numéro Pièce		5412ESEL482408		Rev. 2 0

This drawing is confidential and must not be reproduced or used without the consent of EXM

Ce dessin est confidentiel et ne doit pas être reproduit ou utilisé sans le consentement de EXM

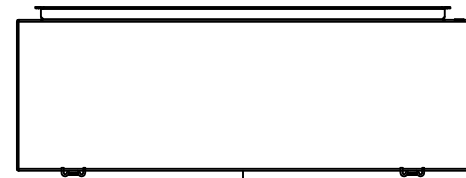

TOP

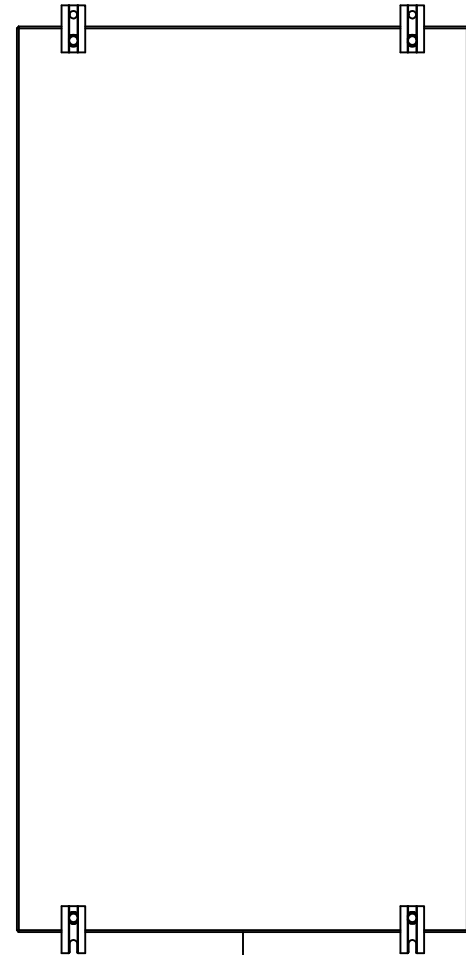

BACK



BOTTOM

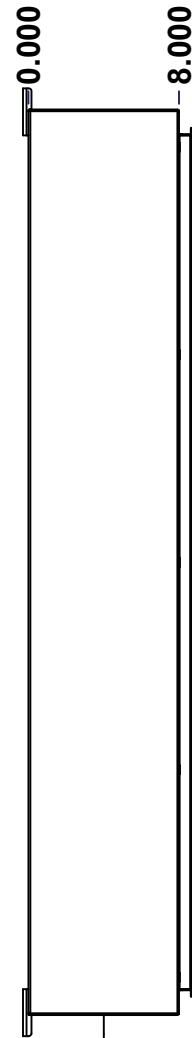

LEFT

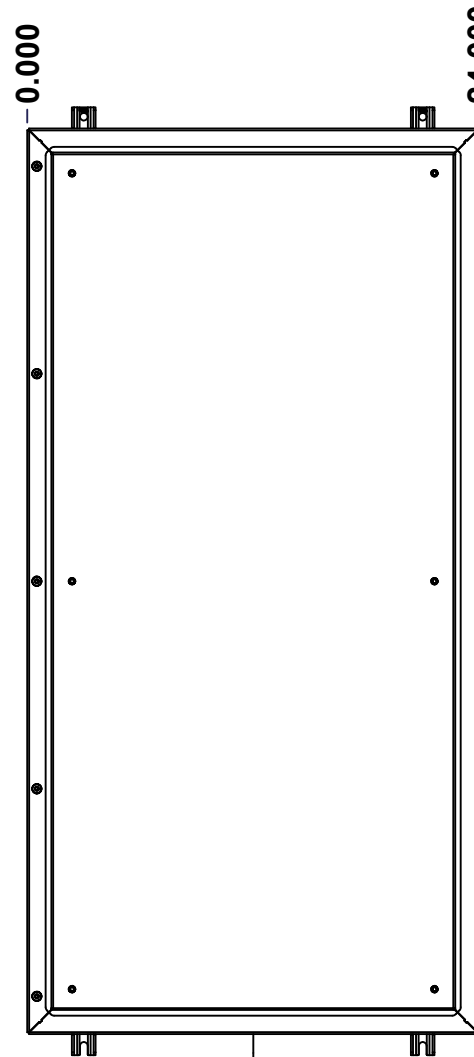

FRONT

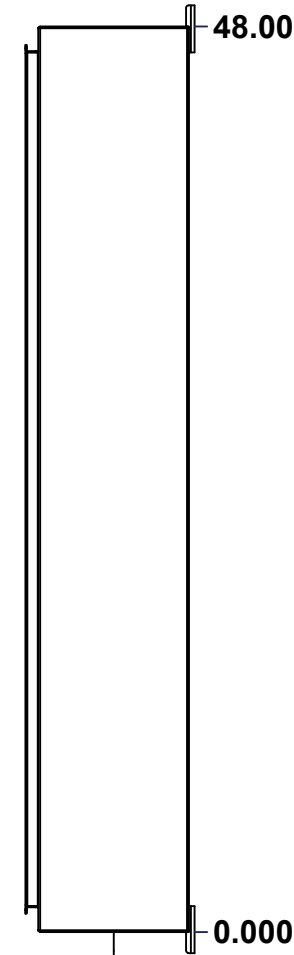

RIGHT

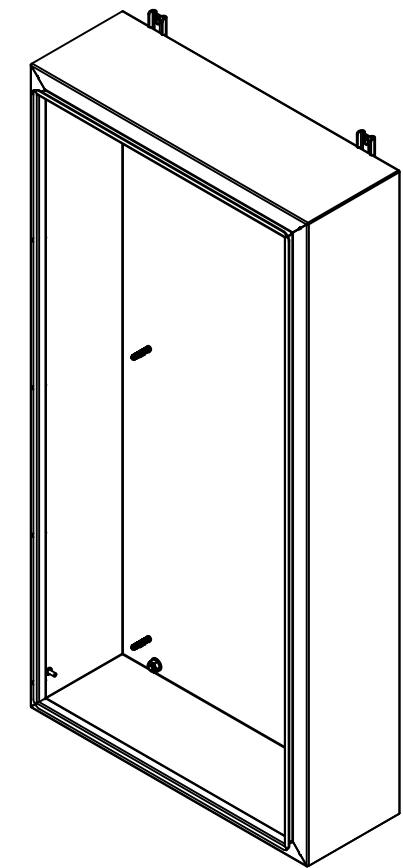

Isometric View

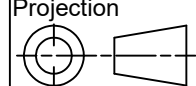

No.	Revisions	Date	By/Par

 Tél: (450) 979-4373 Fax: (450) 979-4626 www.exmweb.com		Flatness Aplatissement Max 3.0mm Projection 
Customer Client	Date	
Drawn By Dessiné Par	BoxCad: BoxCad	Date 20-Mar-20
Material Matière	14 Ga H.R.P. & O. (1.7mm)	
Color Couleur	Asa-61 Grey	Finish Fini Smooth
Description	Detail Rev.	
5412ESEL 48" x 24" x 8" Body		
Part Number Numéro Pièce	Rev.	1 7
5412ESEL482408B	0	

SEE BILL OF MATERIAL ON LAST PAGE

This drawing is confidential and must not be reproduced or used without the consent of EXM

Ce dessin est confidentiel et ne doit pas être reproduit ou utilisé sans le consentement de EXM

STANDARD FEATURES ARE NOT LISTED IN THIS HOLE TABLE			
HOLE TABLE - LEFT VIEW (CUSTOM FEATURE ONLY)			
CUT-OUT	XDIM	YDIM	DESCRIPTION
1	6.500	2.000	GND STUD M6 x 16mm (Inside)

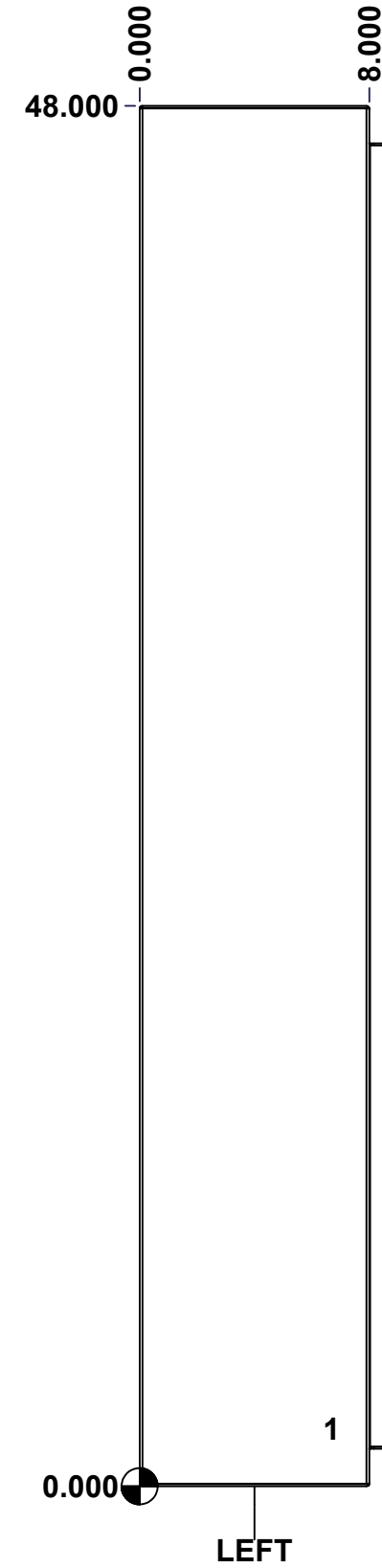

	Description		Status	
	5412ESEL 48" x 24" x 8" Body			
Part Number Numéro Pièce		Rev.	5	7
5412ESEL482408B		0		

This drawing is confidential and must not be reproduced or used without the consent of EXM

Ce dessin est confidentiel et ne doit pas être reproduit ou utilisé sans le consentement de EXM

STANDARD FEATURES ARE NOT LISTED IN THIS HOLE TABLE

HOLE TABLE - BACK VIEW (CUSTOM FEATURE ONLY)

CUT-OUT	XDIM	YDIM	DESCRIPTION
1	2.375	2.375	IP STUD M8 x 35mm (Inside)
2	2.375	45.625	IP STUD M8 x 35mm (Inside)
3	21.625	45.625	IP STUD M8 x 35mm (Inside)
4	21.625	2.375	IP STUD M8 x 35mm (Inside)
5	2.375	24.000	IP STUD M8 x 35mm (Inside)
6	21.625	24.000	IP STUD M8 x 35mm (Inside)

7	21.000	48.000	FOOT 885 ESMF1_CLOSE
8	3.000	48.000	FOOT 885 ESMF1_CLOSE
9	21.000	0.000	FOOT 885 ESMF1_OPEN
10	3.000	0.000	FOOT 885 ESMF1_OPEN

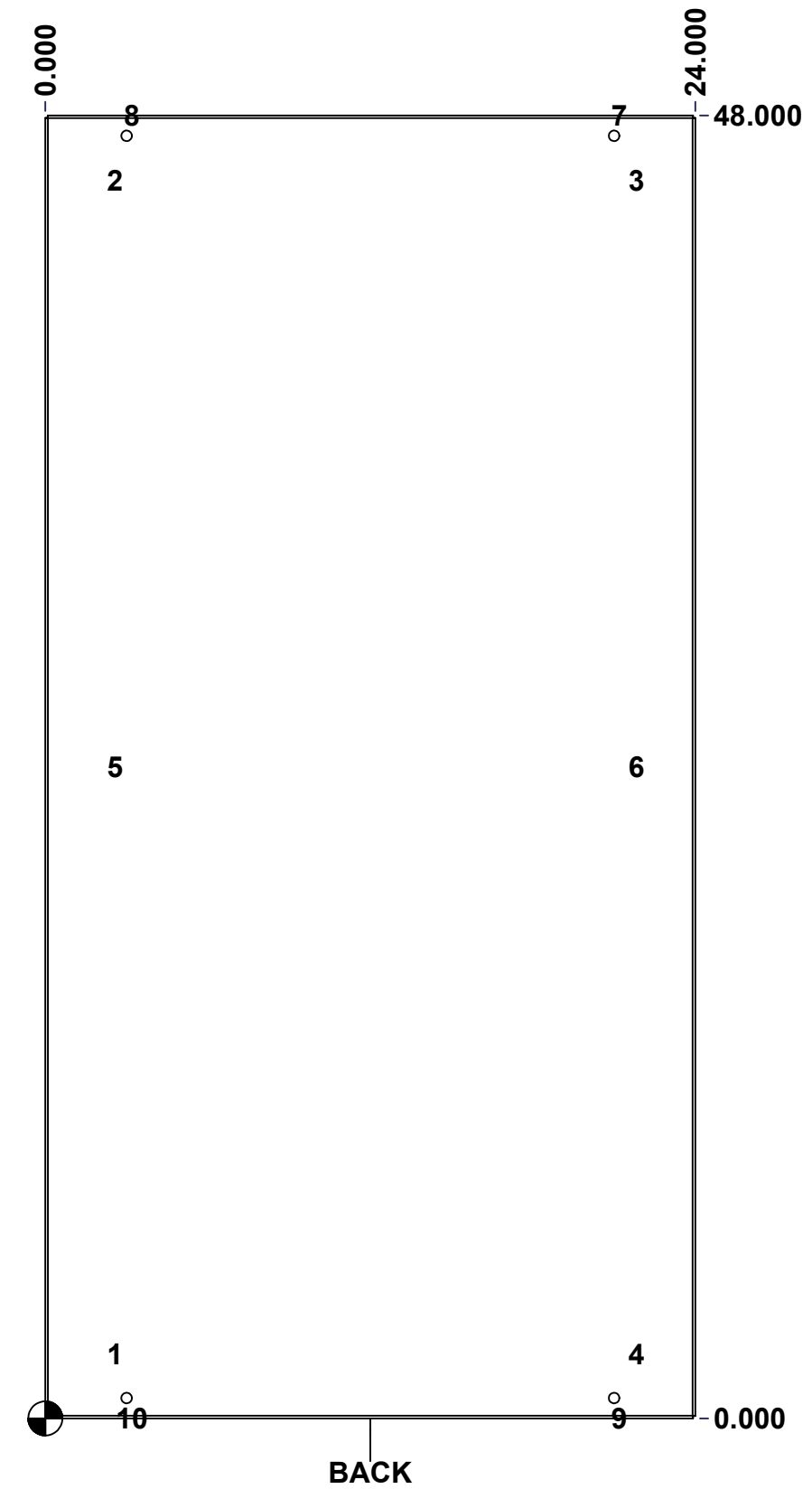

	Description	Status	
	5412ESEL 48" x 24" x 8" Body		
	Part Number	Rev.	6
	Numéro Pièce	0	7
5412ESEL482408B			

This drawing is confidential and must not be reproduced or used without the consent of EXM

Ce dessin est confidentiel et ne doit pas être reproduit ou utilisé sans le consentement de EXM

No.	Revisions	Date	By/Par

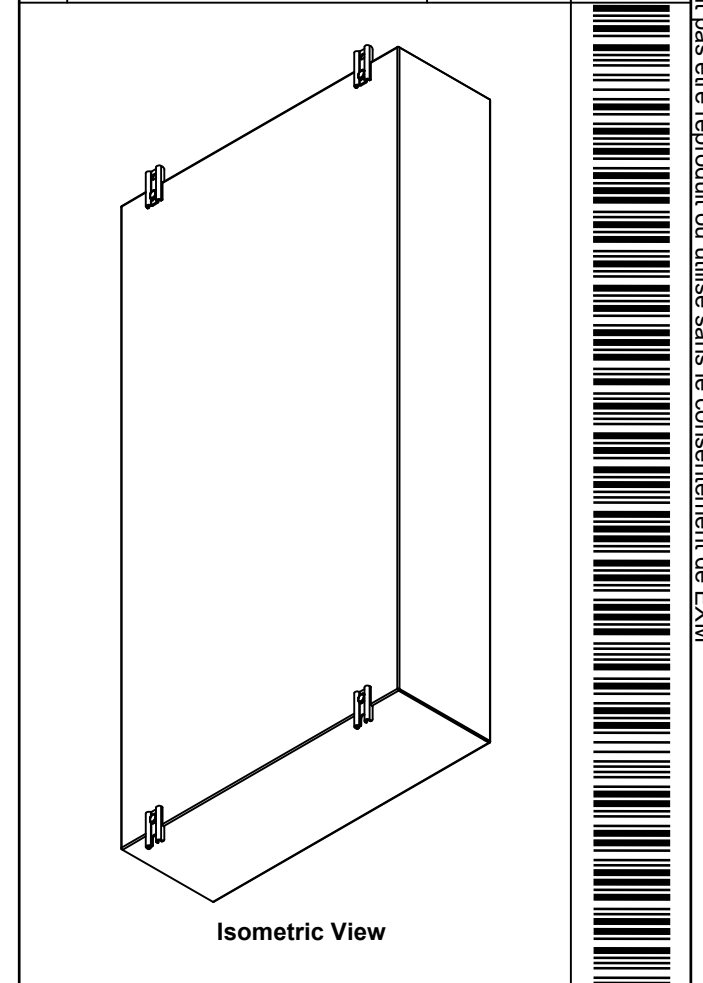

 Tél: (450) 979-4373
 Fax: (450) 979-4626
www.exmweb.com

Flatness / Aplatissement:  Max 3.0mm
 Projection: 

Qty	Part Number	Rev	Description
1	STK-Q-16080	0	Ground Stud M6 x 16mm
5	RIVET_NUT_SS_M6_FH_CE	0	Stainless Steel Rivet Nut M6 (Low Profile Close End)
1	STK-P-02400S	0	Powder Paint (Asa-61 Grey / Smooth)
6	STK-Q-16005	1	Stud M8 x 35 (No Paint Cap Required)
1	MCC_5412ESEL482408B-P	0	5412ESEL 48" x 24" x 8" Body Part
2	885 ESMF1_CLOSE	0	885 ESMF1 Mounting Foot (Closed Hole)
2	885 ESMF1_OPEN	0	885 ESMF1 Mounting Foot (Opened Hole)
Parts List			

Customer Client	Date
Drawn By / Dessiné Par: BoxCad: BoxCad	Date: 20-Mar-20
Material / Matière: 14 Ga H.R.P. & O. (1.7mm)	
Color / Couleur: Asa-61 Grey	Finish / Fini: Smooth
Description: 5412ESEL 48" x 24" x 8" Body	Detail Rev.
Part Number / Numéro Pièce: 5412ESEL482408B	Rev. 0

7 / 7

This drawing is confidential and must not be reproduced or used without the consent of EXM

Ce dessin est confidentiel et ne doit pas être reproduit ou utilisé sans le consentement de EXM



TOP

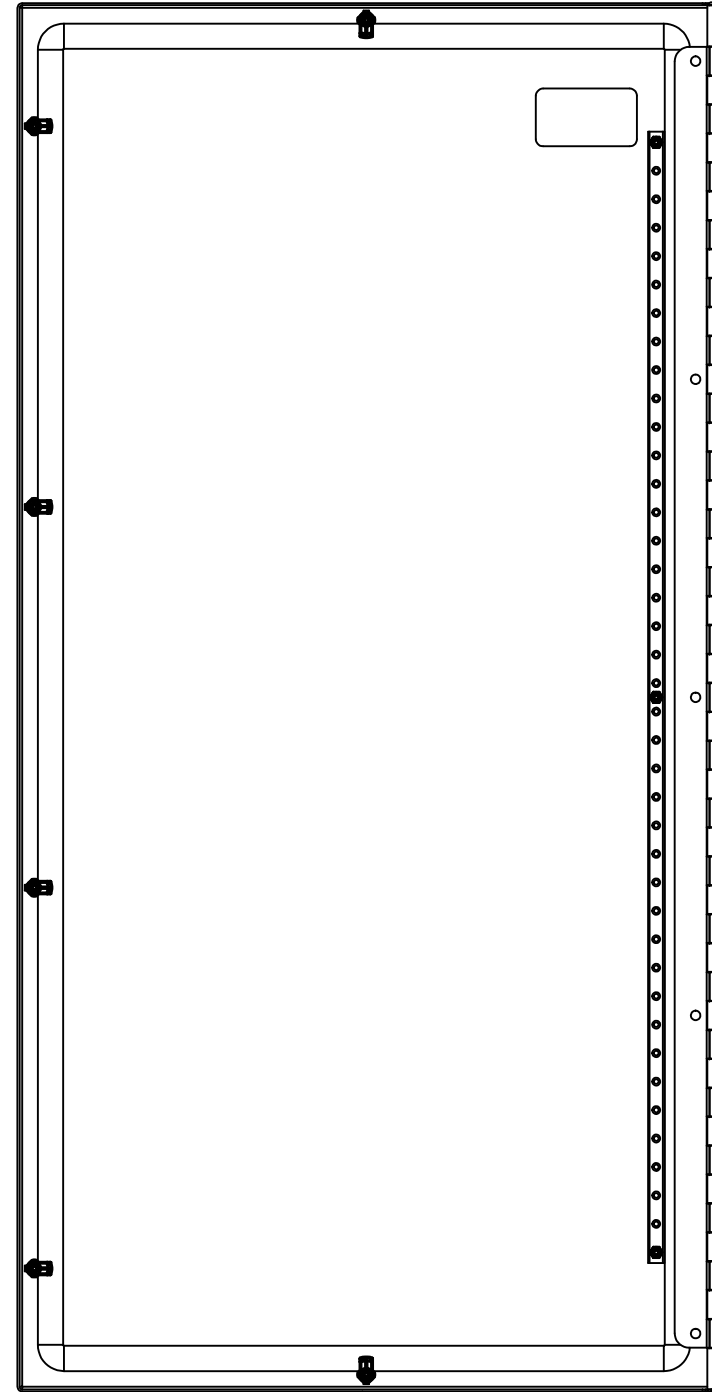

BACK

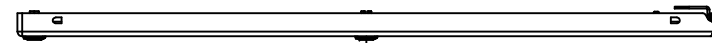

BOTTOM

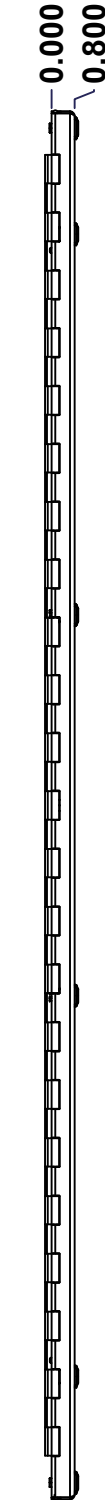

LEFT

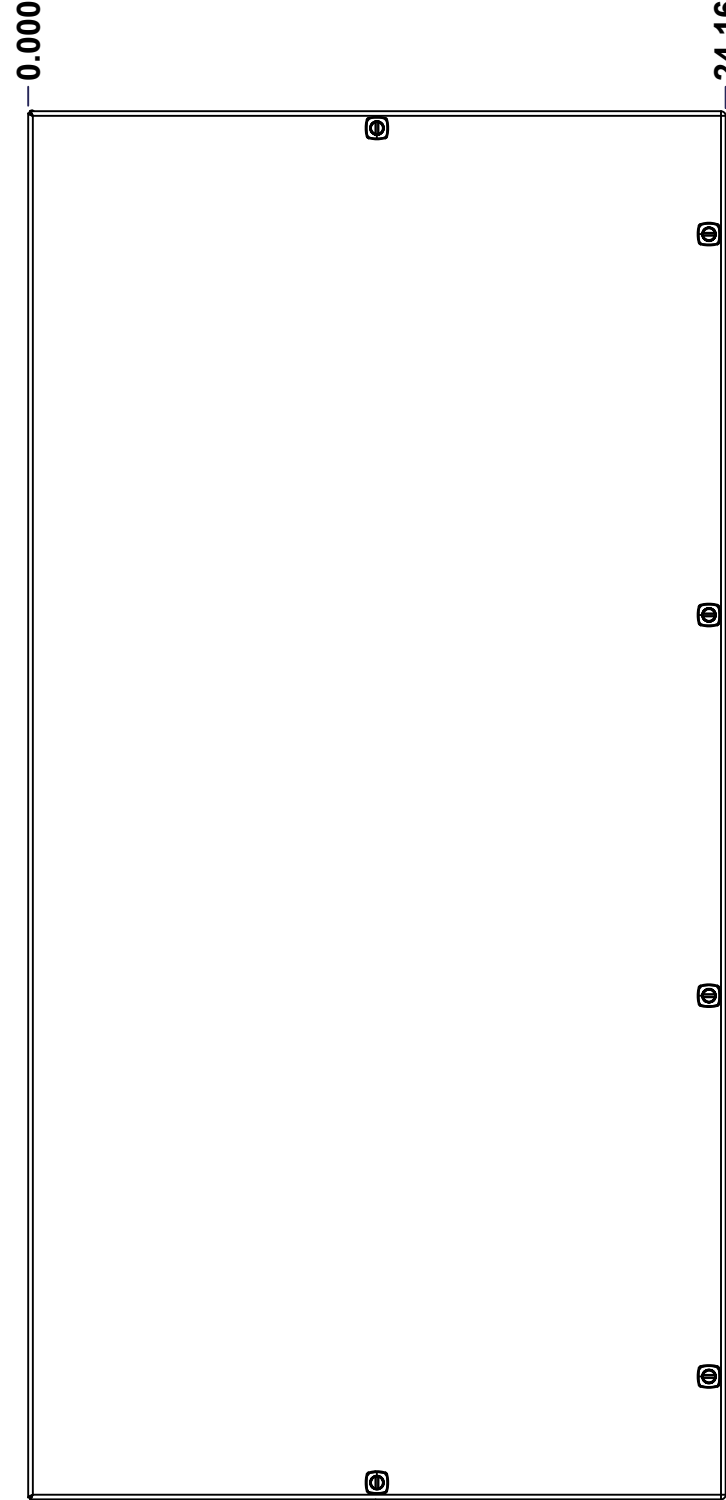

FRONT

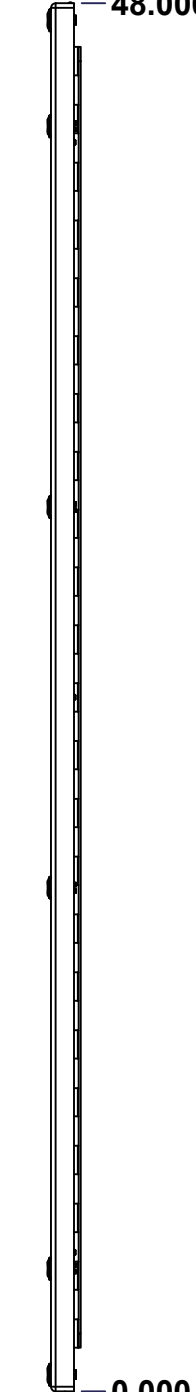

RIGHT

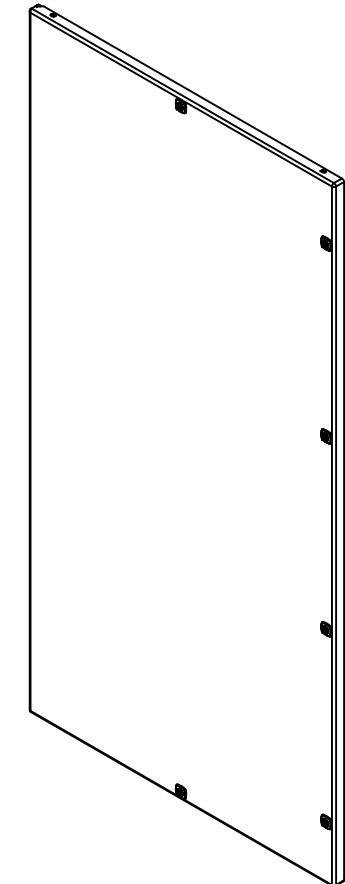

Isometric View

No.	Revisions	Date	By/Par

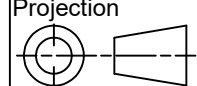

 Tél: (450) 979-4373 Fax: (450) 979-4626 www.exmweb.com		Flatness Aplatissement Max 3.0mm Projection 
Customer Client	Date	
Drawn By Dessiné Par	BoxCad: BoxCad	Date 20-Mar-20
Material Matière	14 Ga H.R.P. & O. (1.7mm)	
Color Couleur	Asa-61 Grey	Finish Fini Smooth
Description	Detail Rev.	
5412ESEL 48" x 24" Cover		
Part Number Numéro Pièce	Rev.	1
5412ESEL482408C	0	3

SEE BILL OF MATERIAL ON LAST PAGE

This drawing is confidential and must not be reproduced or used without the consent of EXM

Ce dessin est confidentiel et ne doit pas être reproduit ou utilisé sans le consentement de EXM

STANDARD FEATURES ARE NOT LISTED IN THIS HOLE TABLE

HOLE TABLE - FRONT VIEW (CUSTOM FEATURE ONLY)

CUT-OUT	XDIM	YDIM	DESCRIPTION
1	2.122	4.807	STUD M6 x 18mm (Inside)
2	2.122	43.193	STUD M6 x 18mm (Inside)
3	2.122	24.000	STUD M6 x 18mm (Inside)

4	4.458	44.053	LABEL_EXM (Inside)
5	23.587	43.750	LOCK 880 SCQ5-SL @ 180.0°
6	23.587	17.417	LOCK 880 SCQ5-SL @ 180.0°
7	23.587	30.583	LOCK 880 SCQ5-SL @ 180.0°
8	12.084	47.420	LOCK 880 SCQ5-SL @ 270.0°
9	12.084	0.580	LOCK 880 SCQ5-SL @ 90.0°
10	23.587	4.250	LOCK 880 SCQ5-SL @ 180.0°

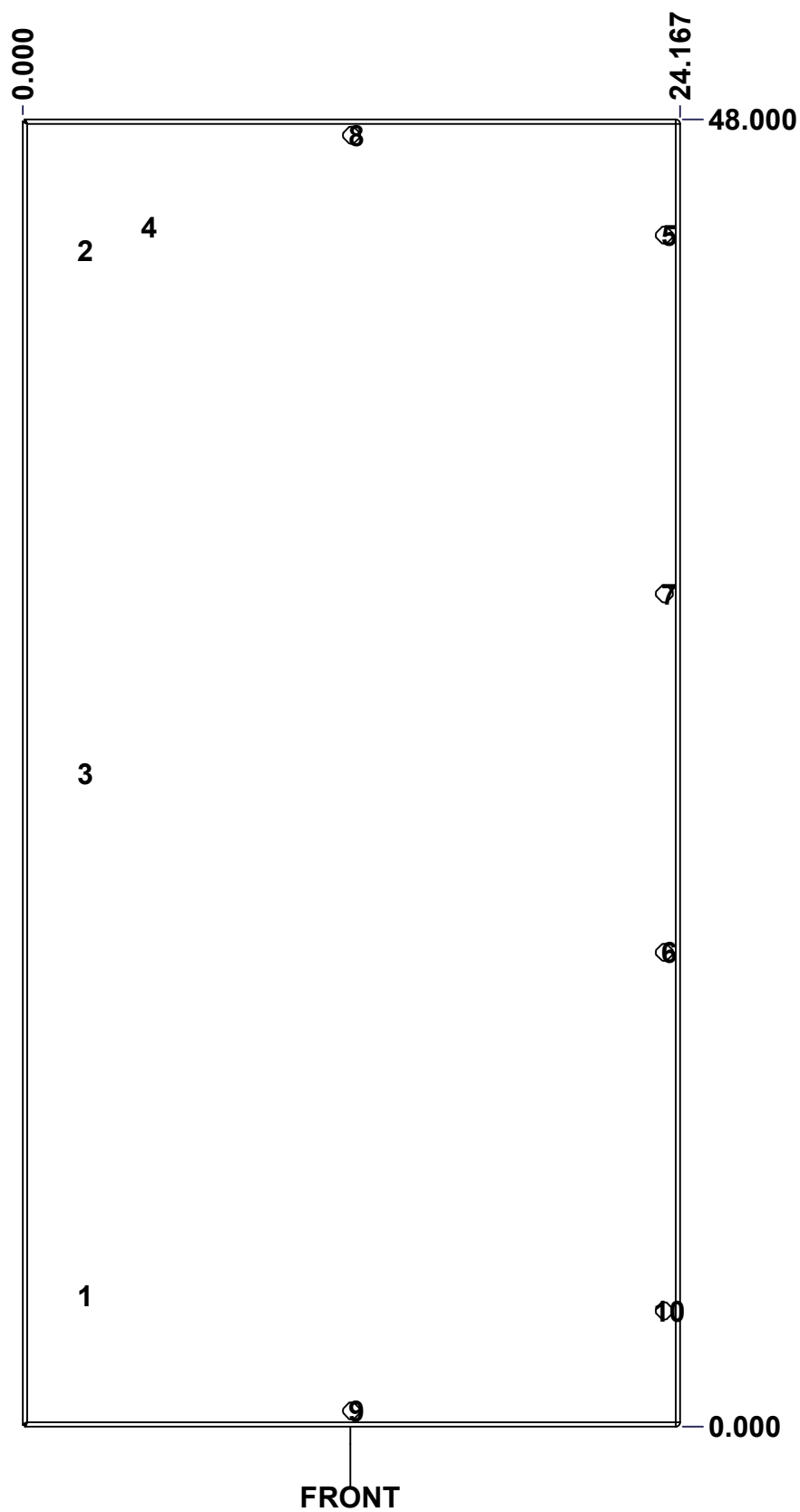

	Description	Status
	5412ESEL 48" x 24" Cover	(NULL)
	Part Number Numéro Pièce	Rev.
	5412ESEL482408C	0
		2
		3

This drawing is confidential and must not be reproduced or used without the consent of EXM

Ce dessin est confidentiel et ne doit pas être reproduit ou utilisé sans le consentement de EXM

No.	Revisions	Date	By/Par

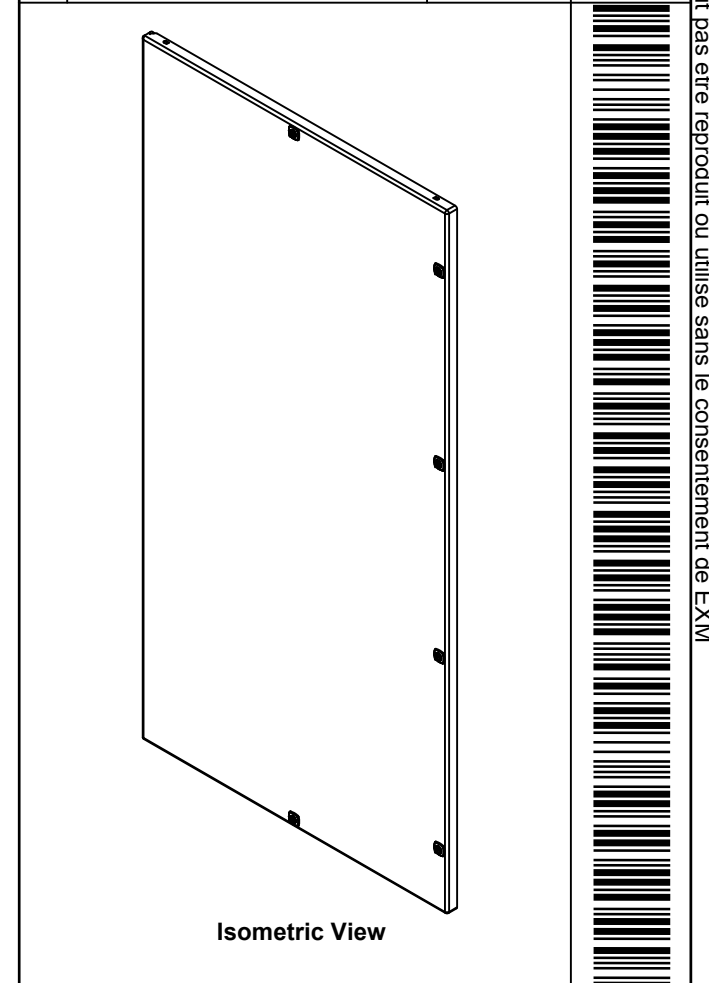

Qty	Part Name	Rev	Description
1	STK-P-02400S	0	Powder Paint (Asa-61 Grey / Smooth)
3	STK-Q-16055	1	M6 x 18mm Stud (No Paint Cap Required)
6	STK-A-79955	2	5412 ESEL Plastic Clip-in 1/4 Turn Lock
1	STK-S-00100	0	3.5" x 2" Silver Milar Flexcon Sticker
1	MCC_5412ESEL482408H-P-P	0	5412ESEL 48" x 24" Cover Part
1	MCC_5412ESEL482408H-P	0	5412ESEL 48" x 24" Cover Part
1	STK-Q-46020-42	5	5412 ES Vertical Door Stiffener 42"
1	MCC_5412ESEL482408G	0	5412ESEL 48" x 24" Cover Gasket Part
1	MCC_5412ESEL482408C-P	0	5412ESEL 48" x 24" Cover Part
3	STK-Q-07220	1	M6 Nylon Insert Lock Nut

Parts List



Tél: (450) 979-4373
Fax: (450) 979-4626
www.exmweb.com

Flatness
Aplatissement
Max 3.0mm

Projection

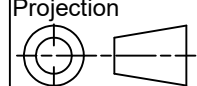

Customer Client		Date
Drawn By Dessiné Par	BoxCad: BoxCad	Date 20-Mar-20
Material Matière 14 Ga H.R.P. & O. (1.7mm)		
Color Couleur	Asa-61 Grey	Finish Fini Smooth
Description 5412ESEL 48" x 24" Cover		Detail Rev.
Part Number Numéro Pièce	5412ESEL482408C	Rev. 3
		0

This drawing is confidential and must not be reproduced or used without the consent of EXM

Ce dessin est confidentiel et ne doit pas être reproduit ou utilisé sans le consentement de EXM

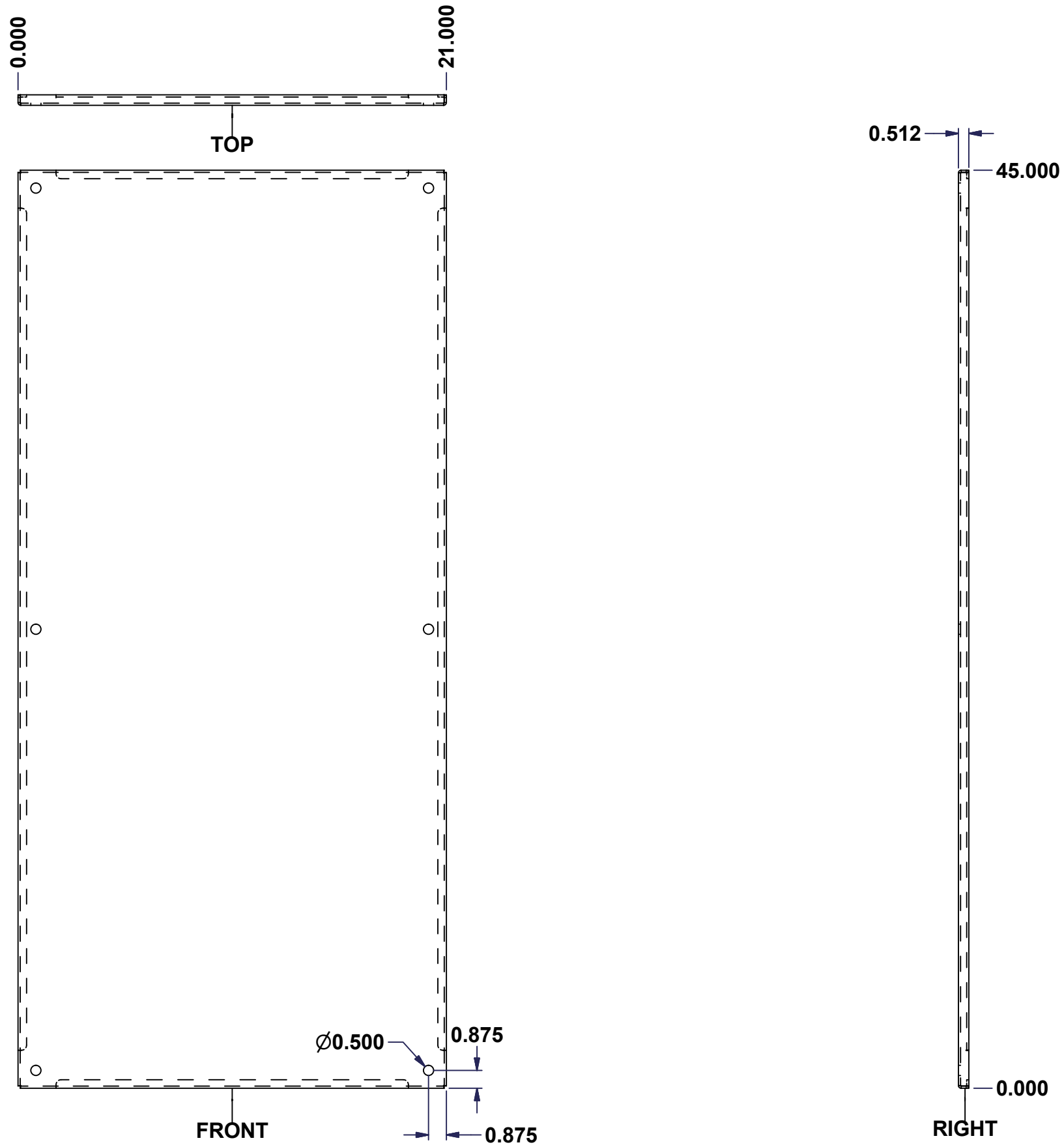

No.	Revisions	Date	By/Par

Isometric View

<p>Tél: (450) 979-4373 Fax: (450) 979-4626 www.exmweb.com</p>		Flatness Aplatissement Max 3.0mm Projection
Customer Client	Date	
Drawn By / Dessiné Par: BoxCad: nickz	Date: 01/03/2017	
Material / Matière: 12 Ga Galvanized (2.5mm)		
Color / Couleur: See Part List	Finish / Fini: See Part List	
Description: 885SP 48" x 24" Inner Panel Part		Detail Rev.
Part Number / Numéro Pièce: 885SP4824G	Rev.:	1

Qty	Part Number	Rev	Description	Material	Color	Finish
1	885SP4824G-P	0	885SP 48" x 24" Inner Panel Part	12 Ga Galvanized (2.5mm)	Unpainted	Galvanized

Parts List