

This drawing is confidential and must not be reproduced or used without the consent of EXM

Ce dessin est confidentiel et ne doit pas être reproduit ou utilisé sans le consentement de EXM

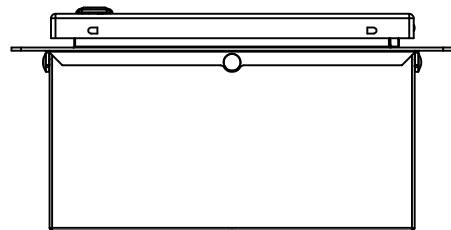

TOP

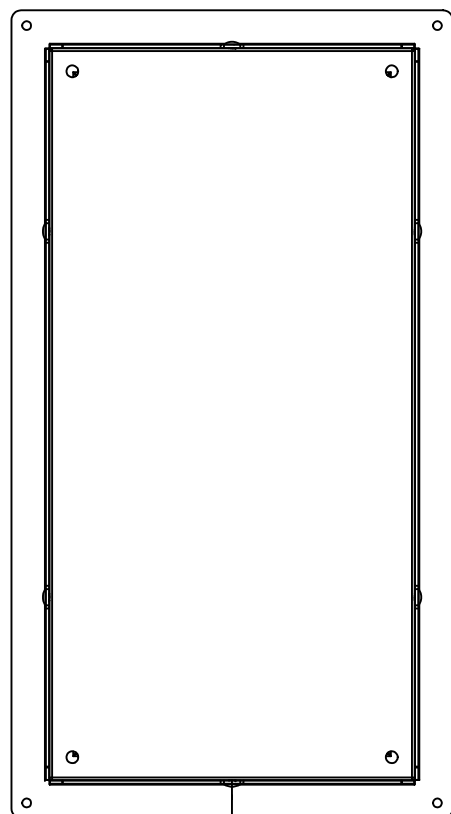

BACK

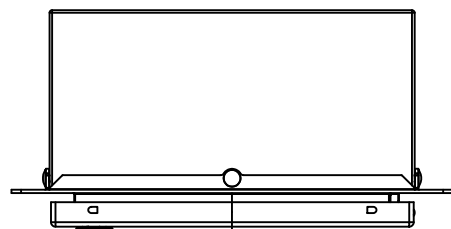

BOTTOM

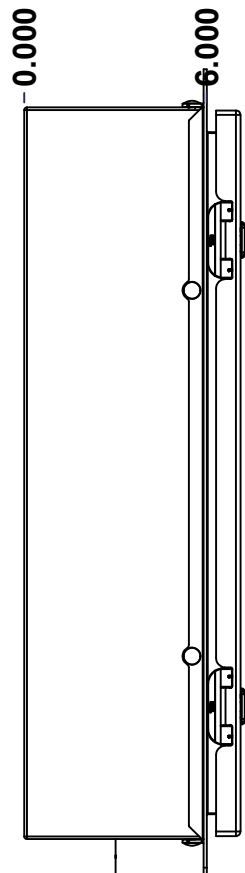

LEFT

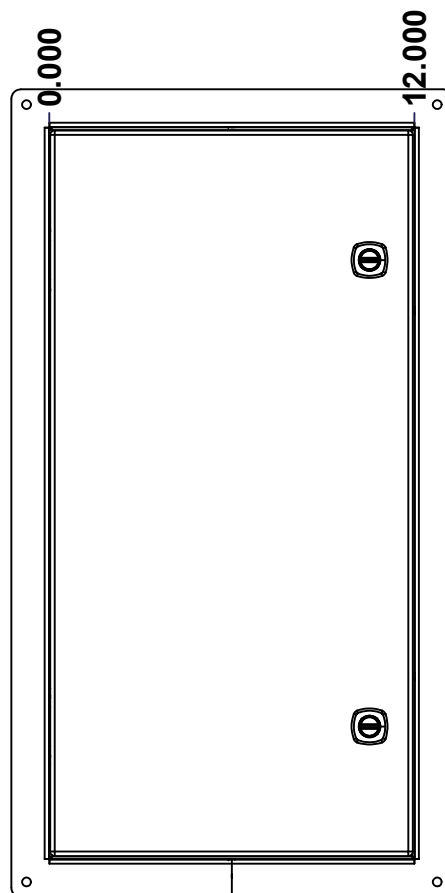

FRONT

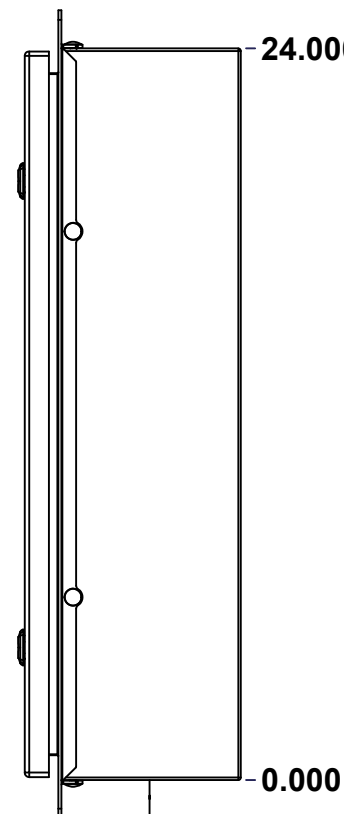

RIGHT

| No. | Revisions | Date | By/Par |
|-----|-----------|------|--------|
|     |           |      |        |
|     |           |      |        |
|     |           |      |        |
|     |           |      |        |
|     |           |      |        |

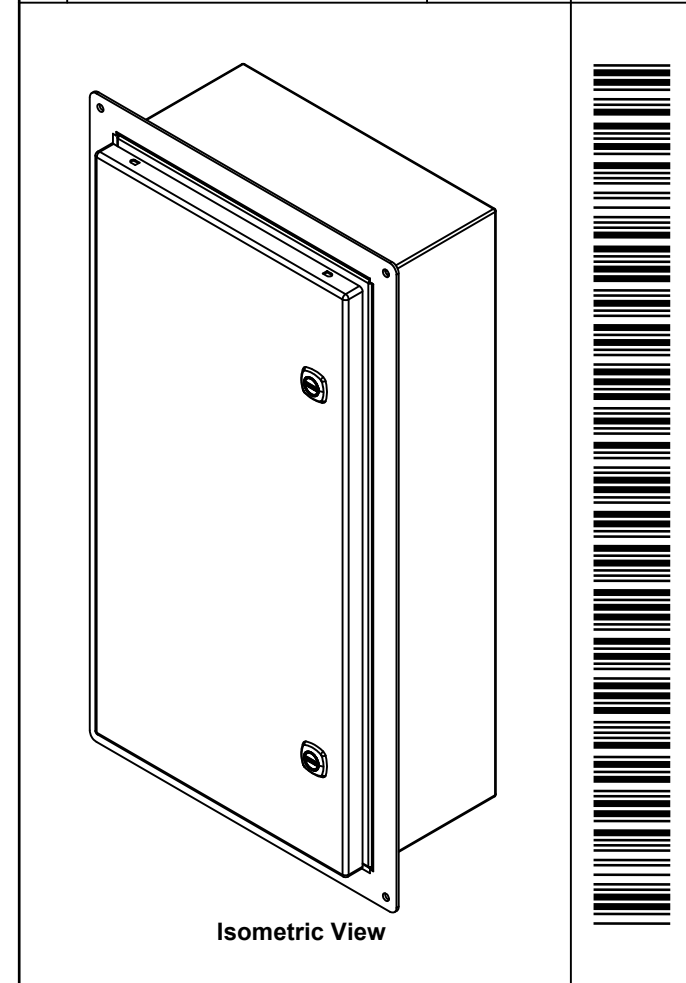

|  |  |                           |        |
|--|--|---------------------------|--------|
| Tél: (450) 979-4373<br>Fax: (450) 979-4626<br><a href="http://www.exmweb.com">www.exmweb.com</a> |  | Flatness<br>Aplatissement |        |
|  |  | Max 3.0mm                 |        |
| Customer<br>Client   |  | Date                      |        |
| Drawn By<br>Dessiné Par BoxCad: BoxCad   |  | Date 12-Feb-14            |        |
| Material<br>Matière 16 Ga H.R.P. & O. (1.4mm)  |  | Projection                |        |
| Color<br>Couleur Asa-61 Grey   |  | Finish<br>Fini Smooth     |        |
| Description<br>5412ESFM 24" x 12" x 6" Assembly  |  | Detail Rev.               |        |
| Part Number<br>Numéro Pièce <b>5412ESFM241206</b>  |  | Rev. <b>0</b>             | 1<br>2 |

SEE BILL OF MATERIAL ON LAST PAGE

This drawing is confidential and must not be reproduced or used without the consent of EXM

Ce dessin est confidentiel et ne doit pas être reproduit ou utilisé sans le consentement de EXM

| NOTE |  |
|------|--|
| ITEM | DESCRIPTION                                |
| 1    | NEMA 4/12 Enclosure                        |
| 2    | C/W Standard ground studs on box and cover |
| 3    | C/W Standard door stiffener                |
| 4    | C/W Standard inner panel (Included)        |
| 5    | C/W Standard inner panel mounting studs    |

| No. | Revisions | Date | By/Par |
|-----|-----------|------|--------|
|     |           |      |        |
|     |           |      |        |
|     |           |      |        |
|     |           |      |        |
|     |           |      |        |
|     |           |      |        |

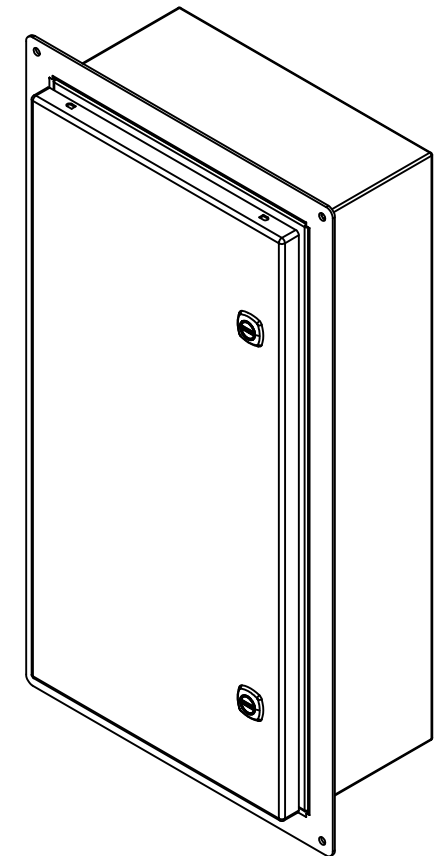

Isometric View

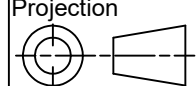

|  |                           |   |
|--|---------------------------|---|
|  Tél: (450) 979-4373<br>Fax: (450) 979-4626<br><a href="http://www.exmweb.com">www.exmweb.com</a> |                           | Flatness<br>Aplatissement<br>Max 3.0mm<br>Projection<br> |
| Customer Client  | Date                      |   |
| Drawn By<br>Dessiné Par  | BoxCad: BoxCad            | Date 12-Feb-14  |
| Material<br>Matière  | 16 Ga H.R.P. & O. (1.4mm) |   |
| Color<br>Couleur   | Asa-61 Grey               | Finish<br>Fini Smooth   |
| Description  | Detail Rev.               |   |
| 5412ESFM 24" x 12" x 6" Assembly   |                           |   |
| Part Number<br>Numéro Pièce  | 5412ESFM241206            | Rev. 0  |

| PACKING               |     |  |
|-----------------------|-----|--|
| ITEM                  | QTY | DESCRIPTION                                |
| Cardboard sleeve      | 2   | Top and Bottom                             |
| Cardboard strip       | 2   | Between back of enclosure and inner panel  |
| Plastic bag           | 1   | To protect cover surface and inside gasket |
| Plastic strap - Black | 2   | To Squeeze the 2 cardboard sleeve together |
| Packaging label       | 1   | White label with product number            |

| Qty        | Part Number     | Rev | Description  |
|------------|-----------------|-----|--|
| 1          | STK-K-01800     | 5   | 5412 ES Accessory Kit                                  |
| 1          | 881 SP2412G     | 0   | 881 SP - Inner Panel                                   |
| 1          | 5412ESFM241206C | 0   | 5412ESFM 24" x 12" Cover                               |
| 4          | STK-Q-07310     | 2   | Flange Lock Nut M8                                     |
| 4          | STK-Q-07610     | 8   | M8 Plastic Spacer 22.2mm                               |
| 1          | 5412ESFM241206B | 0   | 5412ESFM 24" x 12" x 6" Body                           |
| 2          | STK-Q-04050-07  | 7   | M6 x 7mm Hexagon Socket Head Machine Screw with Nyseal |
| Parts List |                 |     |  |

This drawing is confidential and must not be reproduced or used without the consent of EXM

Ce dessin est confidentiel et ne doit pas être reproduit ou utilisé sans le consentement de EXM

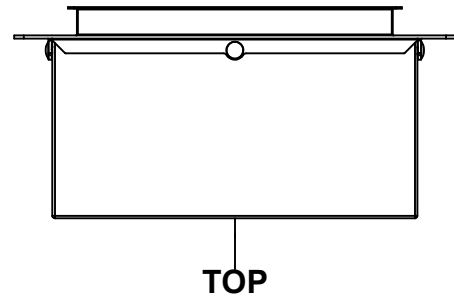

TOP

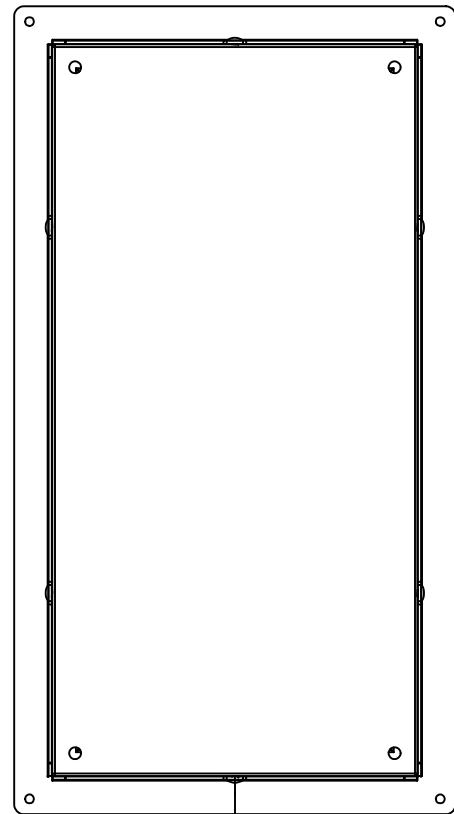

BACK

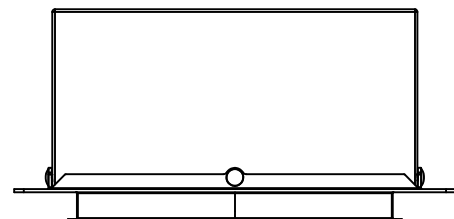

BOTTOM

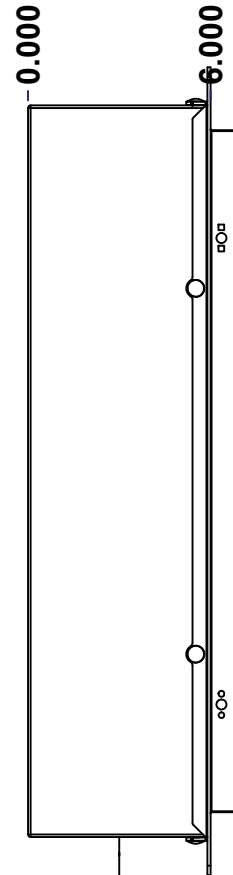

LEFT

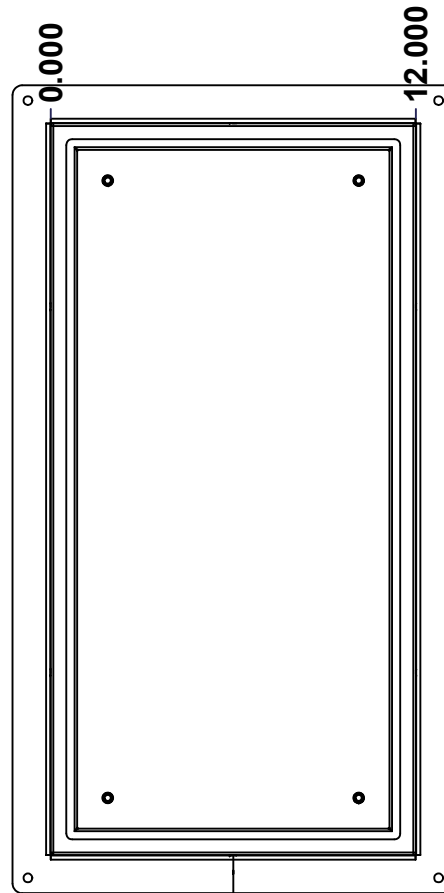

FRONT

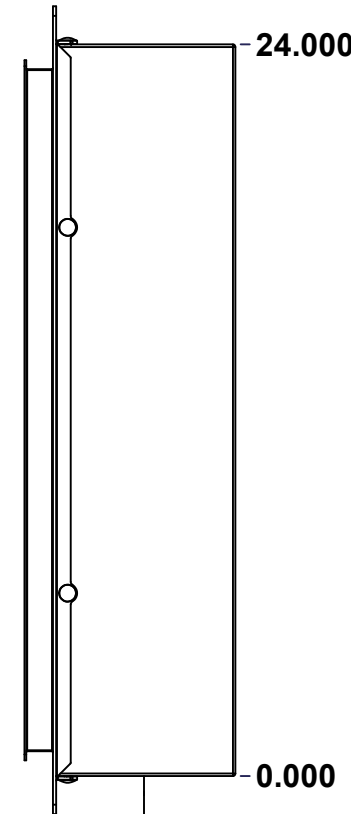

RIGHT

| No. | Revisions | Date | By/Par |
|-----|-----------|------|--------|
|     |           |      |        |
|     |           |      |        |
|     |           |      |        |
|     |           |      |        |

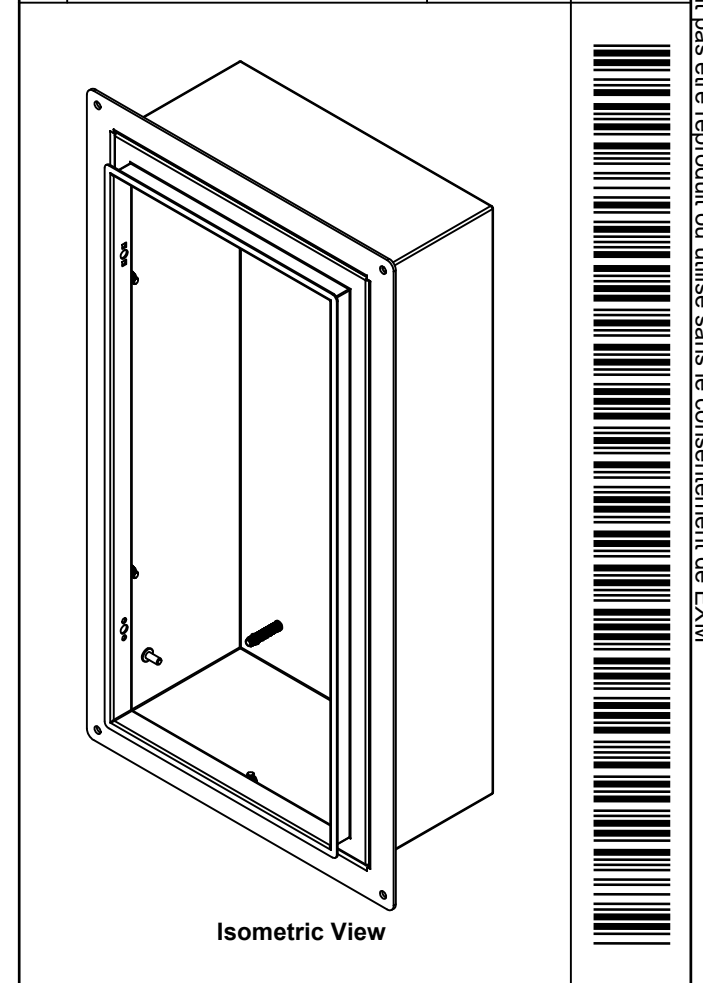

Isometric View

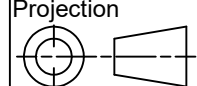

|  |                           |   |
|--|---------------------------|---|
|  Tél: (450) 979-4373<br>Fax: (450) 979-4626<br><a href="http://www.exmweb.com">www.exmweb.com</a> |                           | Flatness<br>Aplatissement<br>Max 3.0mm<br>Projection<br> |
| Customer<br>Client   | Date                      | Date  |
| Drawn By<br>Dessiné Par  | BoxCad: BoxCad            | 12-Feb-14   |
| Material<br>Matière  | 16 Ga H.R.P. & O. (1.4mm) |   |
| Color<br>Couleur   | Asa-61 Grey               | Finish<br>Fini: Smooth  |
| Description  | Detail Rev.               |   |
| 5412ESFM 24" x 12" x 6" Body   |                           |   |
| Part Number<br>Numéro Pièce  | Rev.                      | 1 / 7   |
| <b>5412ESFM241206B</b>   | <b>0</b>                  |   |

SEE BILL OF MATERIAL ON LAST PAGE

This drawing is confidential and must not be reproduced or used without the consent of EXM

Ce dessin est confidentiel et ne doit pas être reproduit ou utilisé sans le consentement de EXM

| <b>STANDARD FEATURES ARE NOT LISTED IN THIS HOLE TABLE</b> |       |       |             |
|--|-------|-------|-------------|
| <b>HOLE TABLE - TOP VIEW (CUSTOM FEATURE ONLY)</b>         |       |       |             |
| CUT-OUT  | XDIM  | YDIM  | DESCRIPTION |
| 1  | 6.000 | 5.514 | RND Ø0.290  |

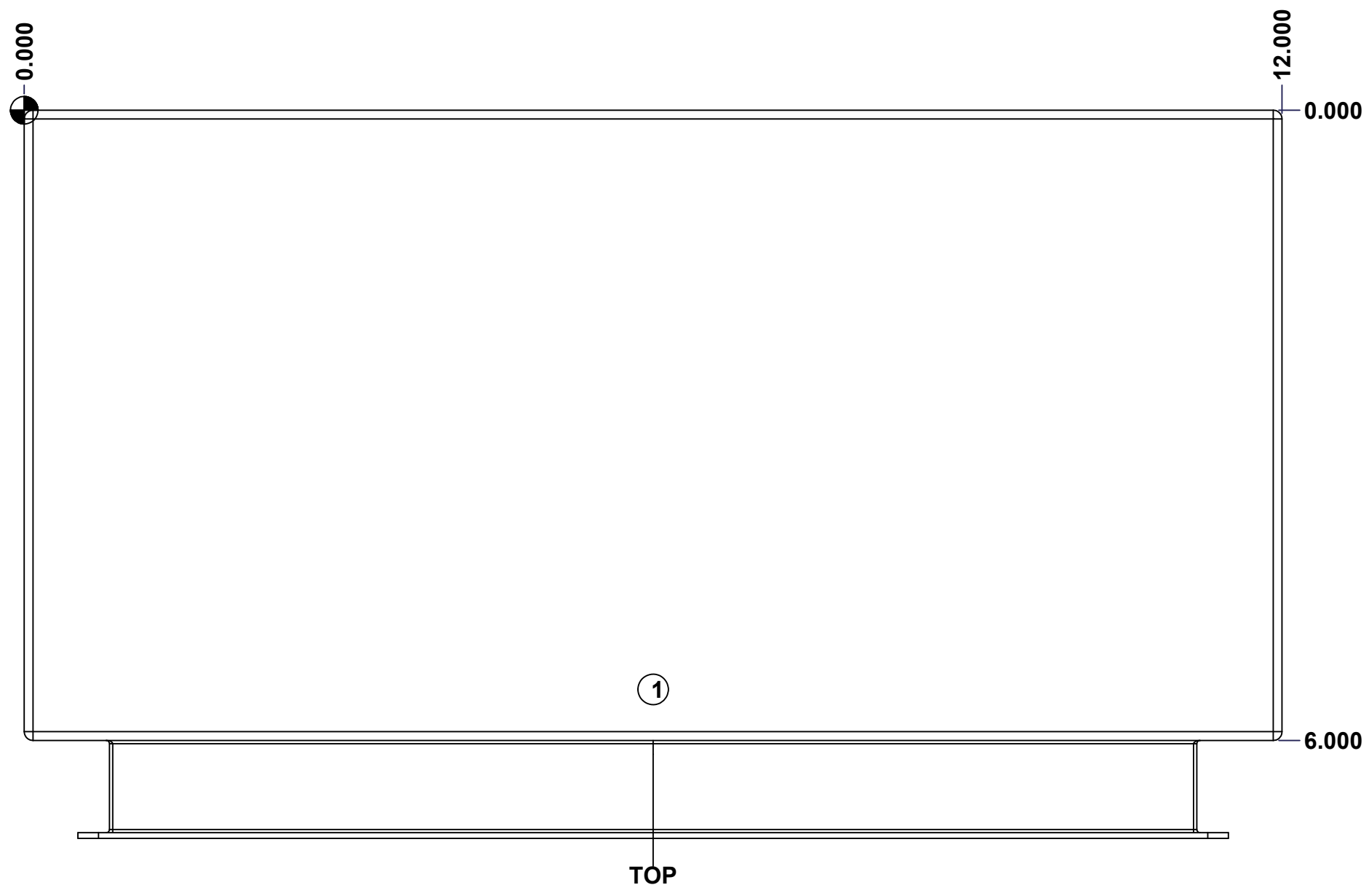

|  |                              |          |   |
|--|------------------------------|----------|---|
|  | Description                  | Status   |   |
|  | 5412ESFM 24" x 12" x 6" Body |          |   |
|  | Part Number<br>Numéro Pièce  | Rev.     | 2 |
|  | <b>5412ESFM241206B</b>       | <b>0</b> | 7 |

This drawing is confidential and must not be reproduced or used without the consent of EXM

Ce dessin est confidentiel et ne doit pas être reproduit ou utilisé sans le consentement de EXM

| STANDARD FEATURES ARE NOT LISTED IN THIS HOLE TABLE |       |        |             |
|---|-------|--------|-------------|
| HOLE TABLE - RIGHT VIEW (CUSTOM FEATURE ONLY)       |       |        |             |
| CUT-OUT   | XDIM  | YDIM   | DESCRIPTION |
| 1   | 5.514 | 18.000 | RND Ø0.290  |
| 2   | 5.514 | 6.000  | RND Ø0.290  |

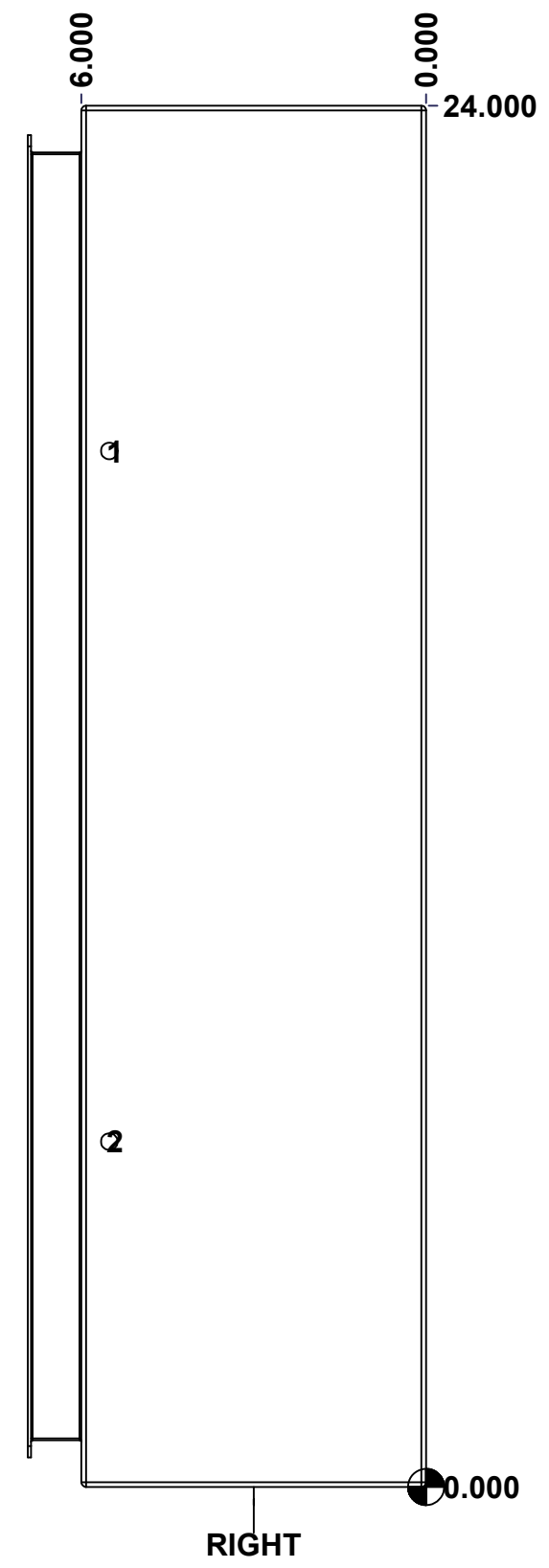

|  |                              |  |          |       |
|--|------------------------------|--|----------|-------|
|  | Description                  |  | Status   |       |
|  | 5412ESFM 24" x 12" x 6" Body |  |          |       |
|  | Part Number<br>Numéro Pièce  |  | Rev.     |       |
|  | <b>5412ESFM241206B</b>       |  | <b>0</b> | 3 / 7 |

This drawing is confidential and must not be reproduced or used without the consent of EXM

Ce dessin est confidentiel et ne doit pas être reproduit ou utilisé sans le consentement de EXM

| <b>STANDARD FEATURES ARE NOT LISTED IN THIS HOLE TABLE</b> |       |       |             |
|--|-------|-------|-------------|
| <b>HOLE TABLE - BOTTOM VIEW (CUSTOM FEATURE ONLY)</b>      |       |       |             |
| CUT-OUT  | XDIM  | YDIM  | DESCRIPTION |
| 1  | 6.000 | 5.514 | RND Ø0.290  |

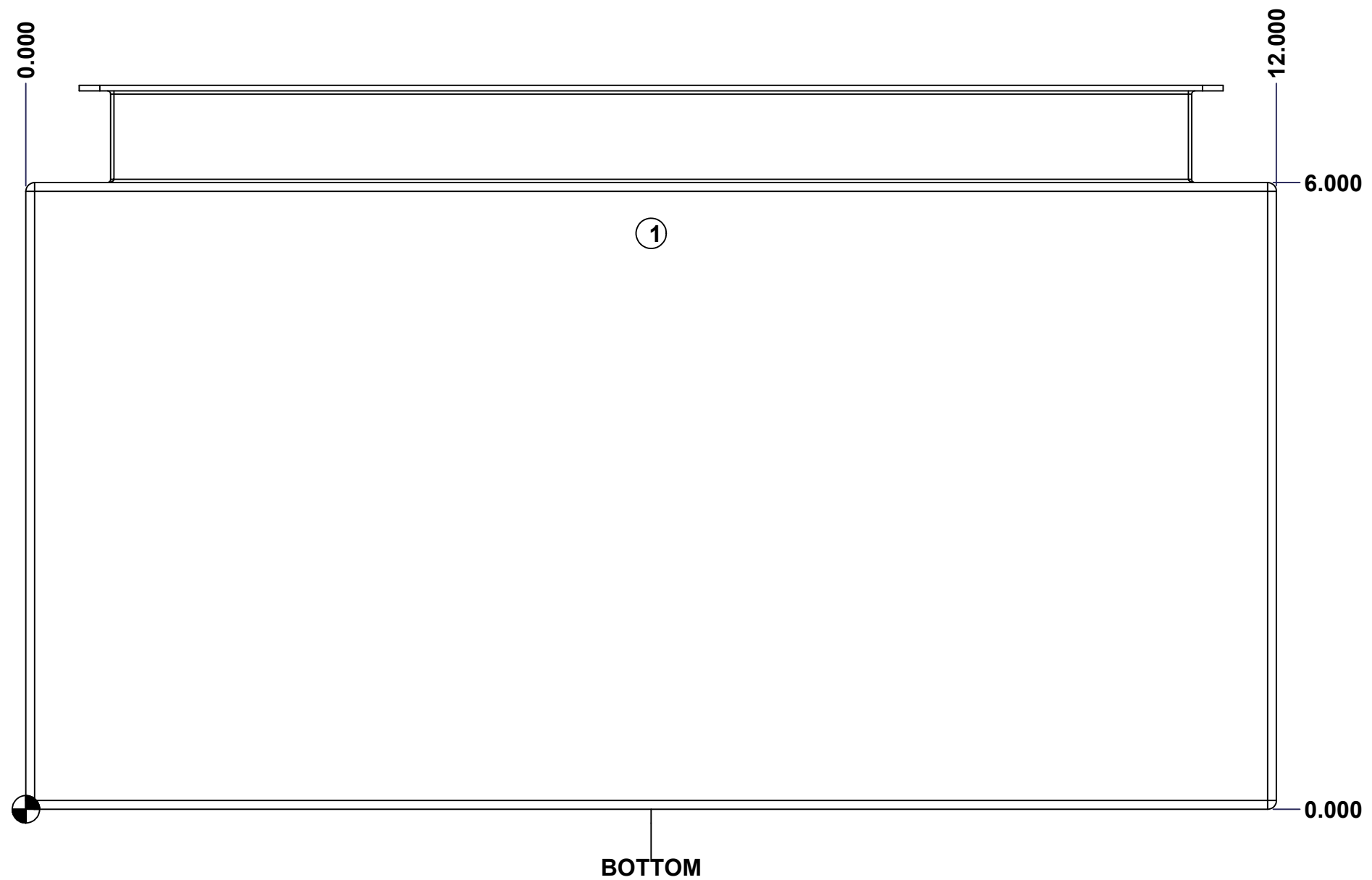

|  |                              |          |
|--|------------------------------|----------|
|  | Description                  | Status   |
|  | 5412ESFM 24" x 12" x 6" Body |          |
|  | Part Number<br>Numéro Pièce  | Rev.     |
|  | <b>5412ESFM241206B</b>       | <b>0</b> |
|  |                              | 4        |
|  |                              | 7        |

This drawing is confidential and must not be reproduced or used without the consent of EXM

Ce dessin est confidentiel et ne doit pas être reproduit ou utilisé sans le consentement de EXM

| STANDARD FEATURES ARE NOT LISTED IN THIS HOLE TABLE |       |        |                             |
|---|-------|--------|-----------------------------|
| HOLE TABLE - LEFT VIEW (CUSTOM FEATURE ONLY)        |       |        |                             |
| CUT-OUT   | XDIM  | YDIM   | DESCRIPTION                 |
| 1   | 5.514 | 18.000 | RND Ø0.290                  |
| 2   | 5.514 | 6.000  | RND Ø0.290                  |
| 3   | 4.500 | 2.000  | GND STUD M6 x 16mm (Inside) |

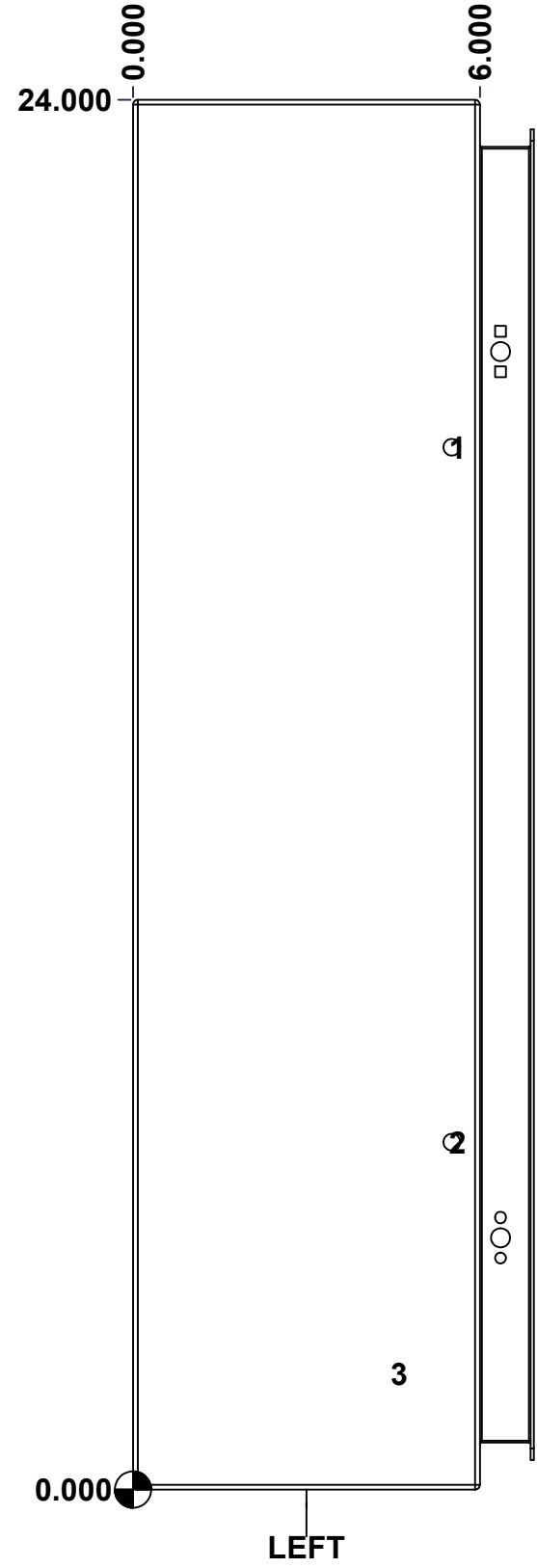

|  |                              |          |   |
|--|------------------------------|----------|---|
|  | Description                  | Status   |   |
|  | 5412ESFM 24" x 12" x 6" Body |          |   |
|  | Part Number<br>Numéro Pièce  | Rev.     | 5 |
|  | <b>5412ESFM241206B</b>       | <b>0</b> | 7 |

This drawing is confidential and must not be reproduced or used without the consent of EXM

Ce dessin est confidentiel et ne doit pas être reproduit ou utilisé sans le consentement de EXM

**STANDARD FEATURES ARE NOT LISTED IN THIS HOLE TABLE**

**HOLE TABLE - BACK VIEW (CUSTOM FEATURE ONLY)**

| CUT-OUT | XDIM   | YDIM   | DESCRIPTION                |
|---------|--------|--------|----------------------------|
| 1       | 1.875  | 1.875  | IP STUD M8 x 35mm (Inside) |
| 2       | 1.875  | 22.125 | IP STUD M8 x 35mm (Inside) |
| 3       | 10.125 | 22.125 | IP STUD M8 x 35mm (Inside) |
| 4       | 10.125 | 1.875  | IP STUD M8 x 35mm (Inside) |
| -----   |        |        |                            |
| 5       | 11.250 | 0.750  | RND Ø0.390                 |
| 6       | 11.250 | 23.250 | RND Ø0.390                 |
| 7       | 0.750  | 23.250 | RND Ø0.390                 |
| 8       | 0.750  | 0.750  | RND Ø0.390                 |

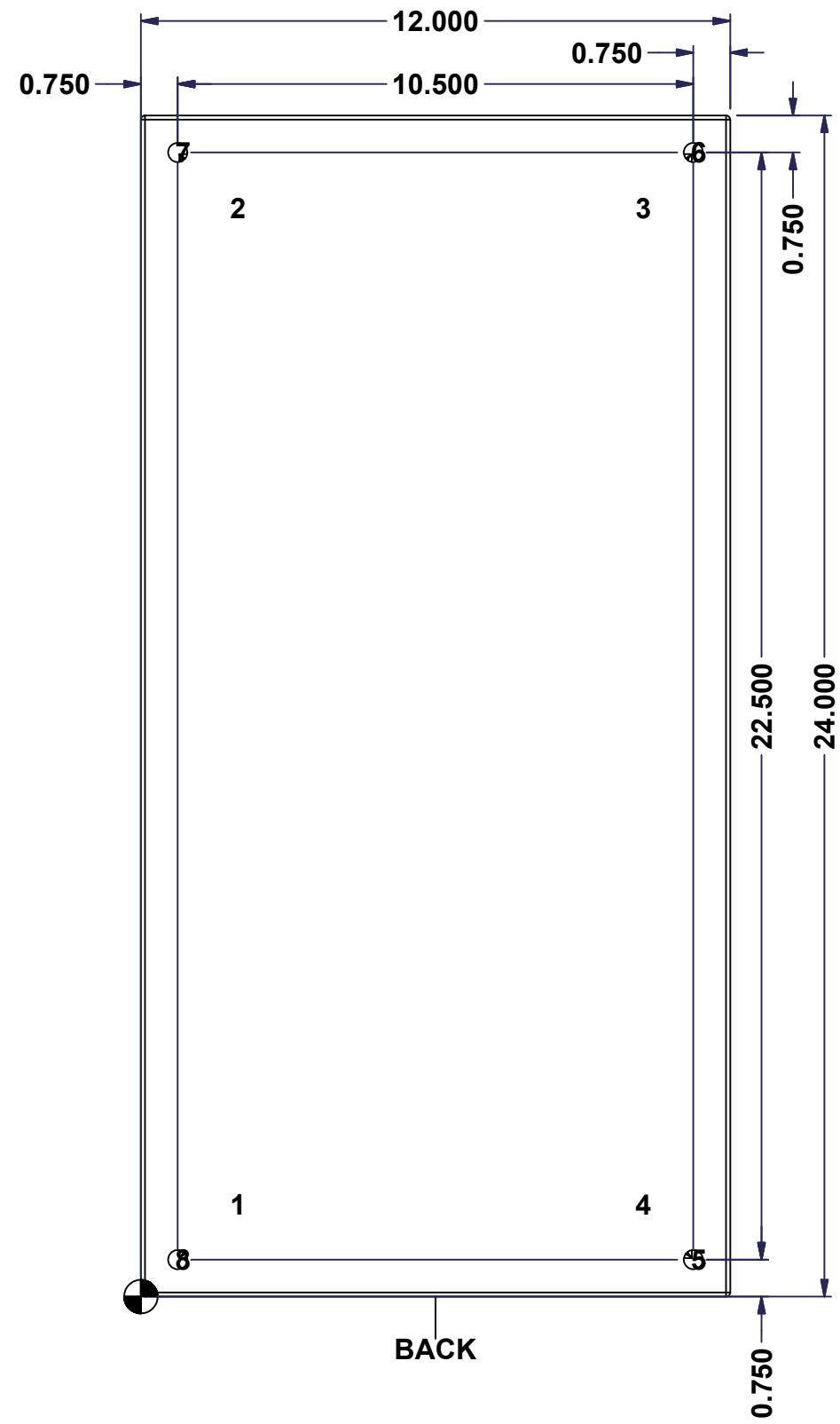

BACK

|  |                              |  |        |   |
|--|------------------------------|--|--------|---|
|  | Description                  |  | Status |   |
|  | 5412ESFM 24" x 12" x 6" Body |  |        |   |
|  | Part Number<br>Numéro Pièce  |  | Rev.   | 6 |
|  | 5412ESFM241206B              |  | 0      | 7 |



This drawing is confidential and must not be reproduced or used without the consent of EXM

Ce dessin est confidentiel et ne doit pas être reproduit ou utilisé sans le consentement de EXM

**STANDARD FEATURES ARE NOT LISTED IN THIS HOLE TABLE**

**HOLE TABLE - FRONT VIEW (CUSTOM FEATURE ONLY)**

| CUT-OUT | XDIM   | YDIM   | DESCRIPTION |
|---------|--------|--------|-------------|
| 1       | 14.000 | 0.500  | RND Ø0.290  |
| 2       | 14.000 | 26.000 | RND Ø0.290  |
| 3       | 0.500  | 26.000 | RND Ø0.290  |
| 4       | 0.500  | 0.500  | RND Ø0.290  |

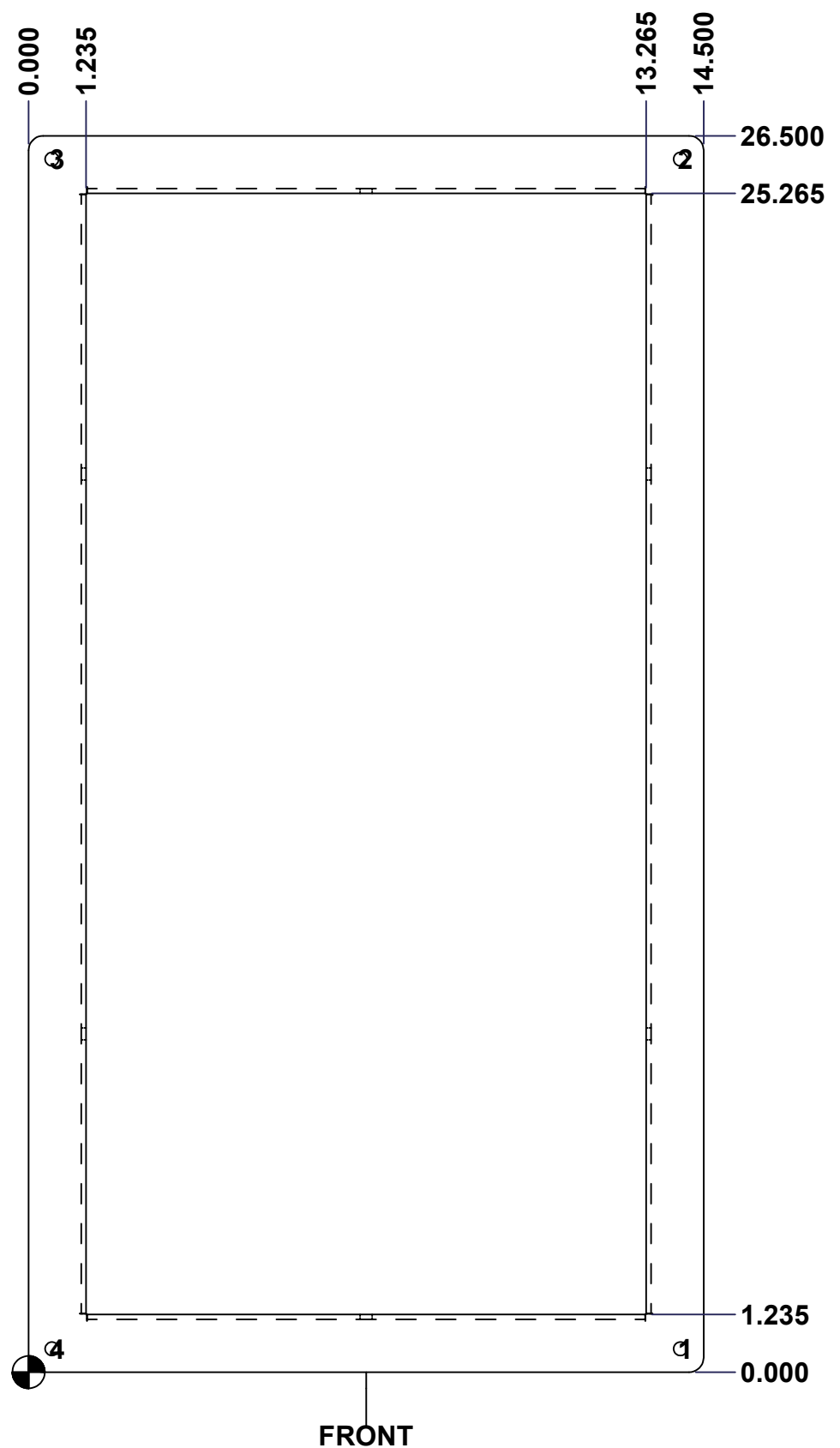

|  |                                |          |     |
|--|--------------------------------|----------|-----|
|  | Description                    | Status   |     |
|  | 5412ESFM 24" x 12" x 6" Flange |          |     |
|  | Part Number<br>Numéro Pièce    | Rev.     | 1/1 |
|  | <b>5412ESFM241206B</b>         | <b>0</b> |     |

This drawing is confidential and must not be reproduced or used without the consent of EXM

Ce dessin est confidentiel et ne doit pas être reproduit ou utilisé sans le consentement de EXM

| No. | Revisions | Date | By/Par |
|-----|-----------|------|--------|
|     |           |      |        |
|     |           |      |        |
|     |           |      |        |
|     |           |      |        |
|     |           |      |        |

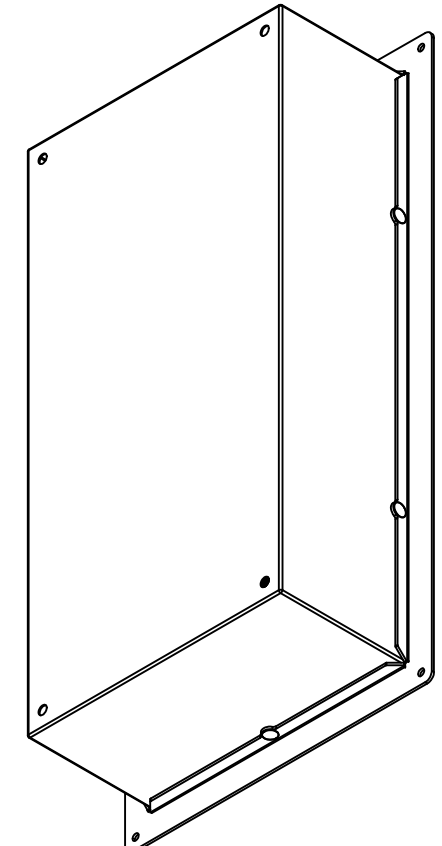

Isometric View

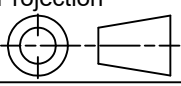

|  |                       |   |
|--|-----------------------|---|
|  Tél: (450) 979-4373<br>Fax: (450) 979-4626<br><a href="http://www.exmweb.com">www.exmweb.com</a> |                       | Flatness<br>Aplatissement<br>Max 3.0mm<br>Projection<br> |
| Customer Client  | Date                  |   |
| Drawn By / Dessiné Par: BoxCad: BoxCad   | Date: 12-Feb-14       |   |
| Material / Matière: 16 Ga H.R.P. & O. (1.4mm)  |                       |   |
| Color / Couleur: Asa-61 Grey   | Finish / Fini: Smooth |   |
| Description: 5412ESFM 24" x 12" x 6" Body  |                       | Detail Rev.   |
| Part Number / Numéro Pièce: <b>5412ESFM241206B</b>   | Rev.:                 | 7   |
|  |                       | 0   |

| Qty        | Part Number       | Rev | Description                          |
|------------|-------------------|-----|--------------------------------------|
| 1          | STK-Q-16080       | 0   | Ground Stud M6 x 16mm                |
| 1          | 5412ESFM241206F   | 0   | 5412ESFM 24" x 12" x 6" Flange       |
| 1          | STK-P-02400S      | 0   | Powder Paint (Asa-61 Grey / Smooth)  |
| 4          | STK-Q-16005       | 1   | Stud M8 x 35 (No Paint Cap Required) |
| 1          | 5412ESFM241206B-P | 0   | 5412ESFM 24" x 12" x 6" Body Part    |
| Parts List |                   |     |                                      |

This drawing is confidential and must not be reproduced or used without the consent of EXM

Ce dessin est confidentiel et ne doit pas être reproduit ou utilisé sans le consentement de EXM

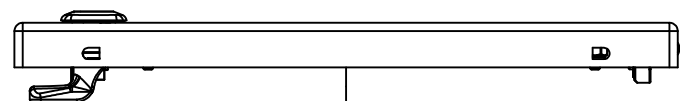

TOP

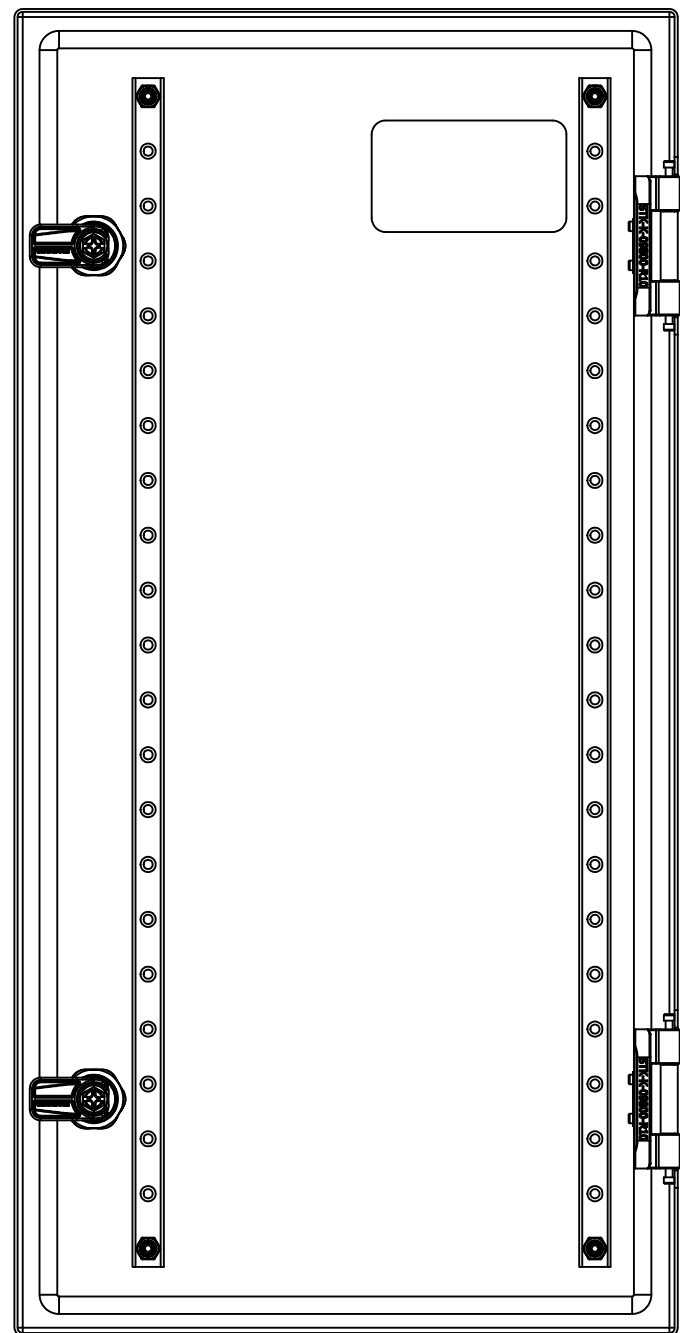

BACK

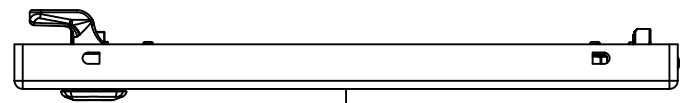

BOTTOM

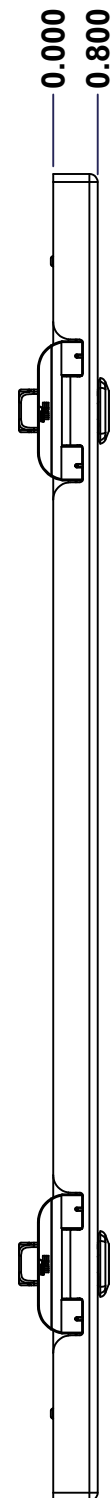

LEFT

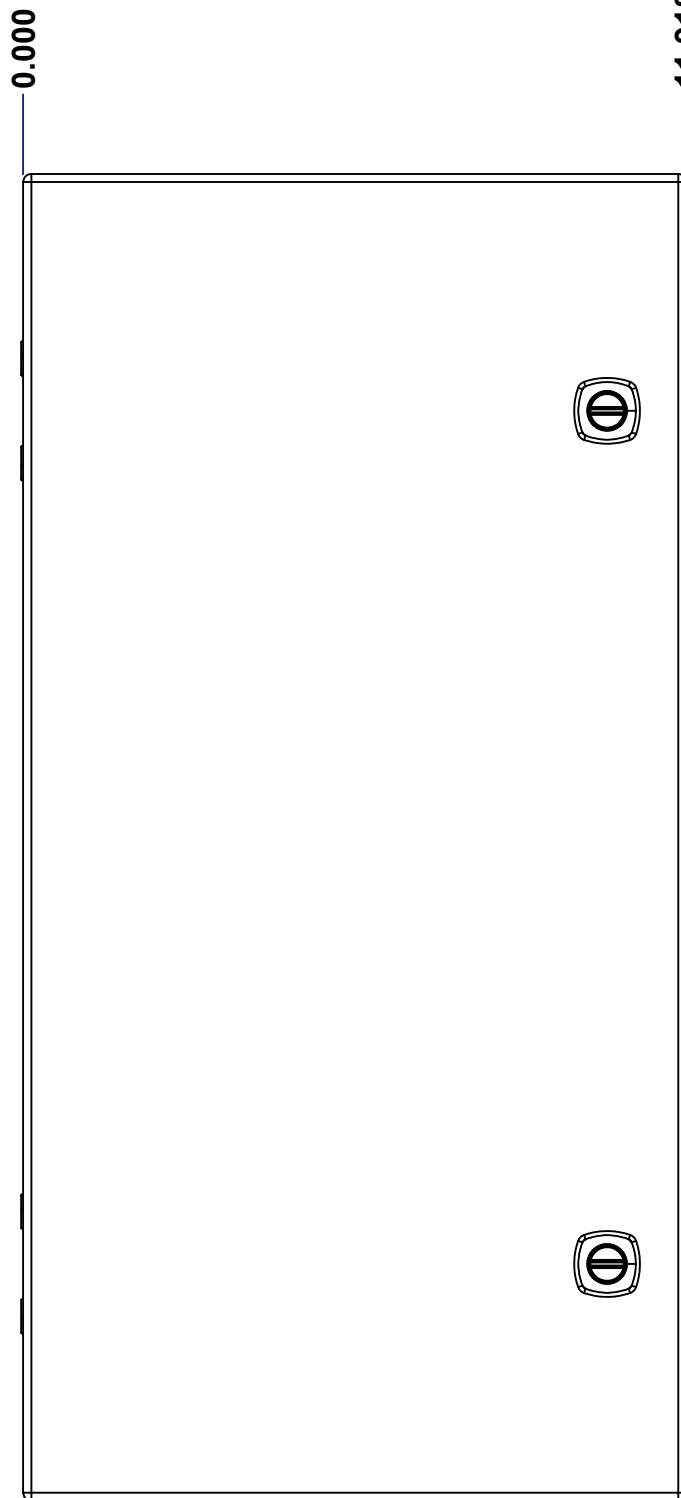

FRONT

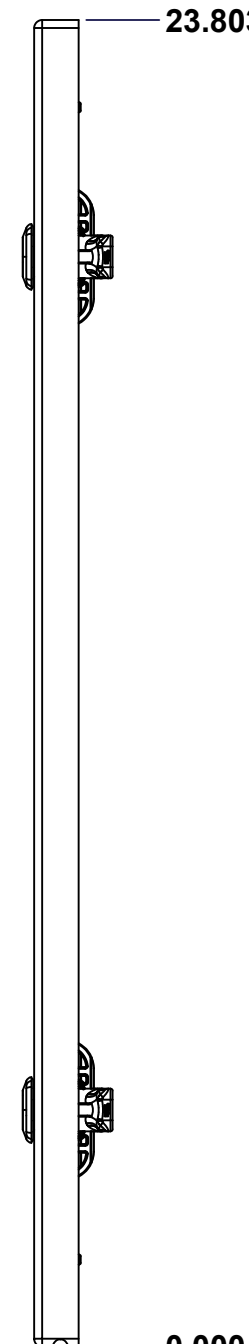

RIGHT

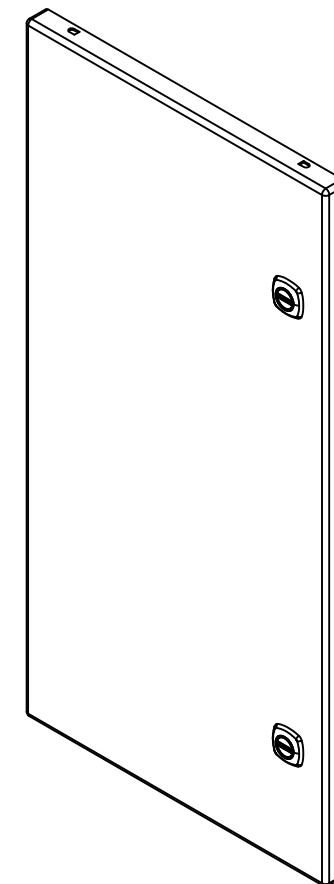

Isometric View

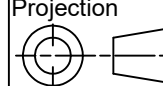

| No. | Revisions | Date | By/Par |
|-----|-----------|------|--------|
|     |           |      |        |
|     |           |      |        |
|     |           |      |        |
|     |           |      |        |
|     |           |      |        |

|  |                |   |
|--|----------------|---|
|  Tél: (450) 979-4373<br>Fax: (450) 979-4626<br><a href="http://www.exmweb.com">www.exmweb.com</a> |                | Flatness<br>Aplatissement<br>Max 3.0mm<br>Projection<br> |
| Customer<br>Client   | Date           | Date  |
| Drawn By<br>Dessiné Par  | BoxCad: BoxCad | Date 12-Feb-14  |
| Material<br>Matière 16 Ga H.R.P. & O. (1.4mm)  |                |   |
| Color<br>Couleur   | Asa-61 Grey    | Finish<br>Fini Smooth   |
| Description<br>5412ESFM 24" x 12" Cover  |                | Detail Rev.   |
| Part Number<br>Numéro Pièce  | Rev. 0         | 1<br>3  |

SEE BILL OF MATERIAL ON LAST PAGE

**5412ESFM241206C**

This drawing is confidential and must not be reproduced or used without the consent of EXM

Ce dessin est confidentiel et ne doit pas être reproduit ou utilisé sans le consentement de EXM

| STANDARD FEATURES ARE NOT LISTED IN THIS HOLE TABLE |        |        |                         |
|---|--------|--------|-------------------------|
| HOLE TABLE - FRONT VIEW (CUSTOM FEATURE ONLY)       |        |        |                         |
| CUT-OUT   | XDIM   | YDIM   | DESCRIPTION             |
| 1   | 1.486  | 1.567  | STUD M6 x 18mm (Inside) |
| 2   | 1.486  | 22.236 | STUD M6 x 18mm (Inside) |
| 3   | 9.517  | 22.236 | STUD M6 x 18mm (Inside) |
| 4   | 9.517  | 1.567  | STUD M6 x 18mm (Inside) |
| -----   |        |        |                         |
| 5   | 3.750  | 20.803 | LABEL_EXM (Inside)      |
| 6   | 10.494 | 19.553 | LOCK 880 SCQ4-SL @ 0.0° |
| 7   | 10.494 | 4.250  | LOCK 880 SCQ4-SL @ 0.0° |

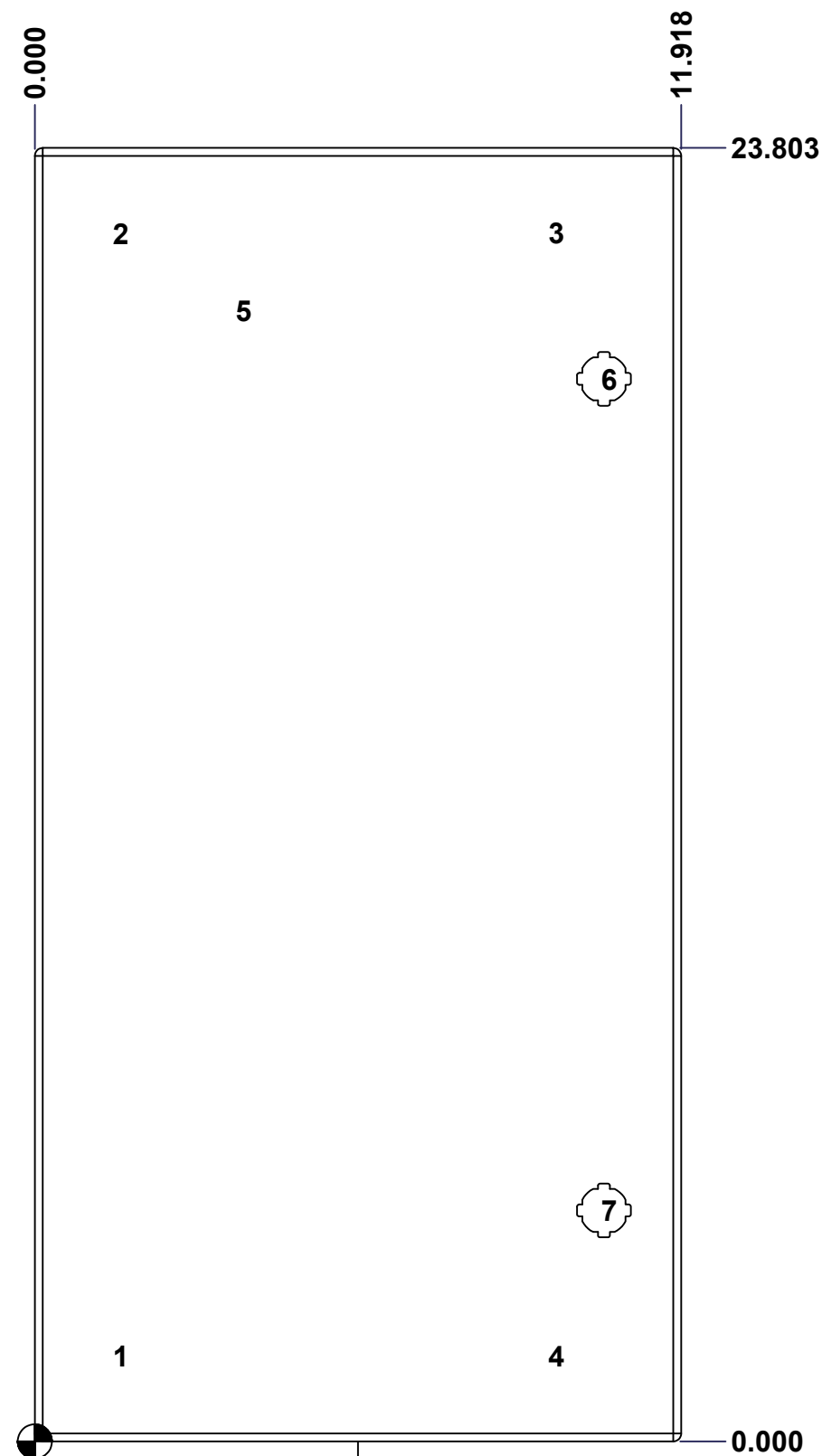

FRONT

|  |                             |                  |
|--|-----------------------------|------------------|
|  | Description                 | Status           |
|  | 5412ESFM 24" x 12" Cover    | (NULL)           |
|  | Part Number<br>Numéro Pièce | Rev.             |
|  | <b>5412ESFM241206C</b>      | <b>0</b> / 2 / 3 |

This drawing is confidential and must not be reproduced or used without the consent of EXM

Ce dessin est confidentiel et ne doit pas être reproduit ou utilisé sans le consentement de EXM

| No. | Revisions | Date | By/Par |
|-----|-----------|------|--------|
|     |           |      |        |
|     |           |      |        |
|     |           |      |        |
|     |           |      |        |
|     |           |      |        |

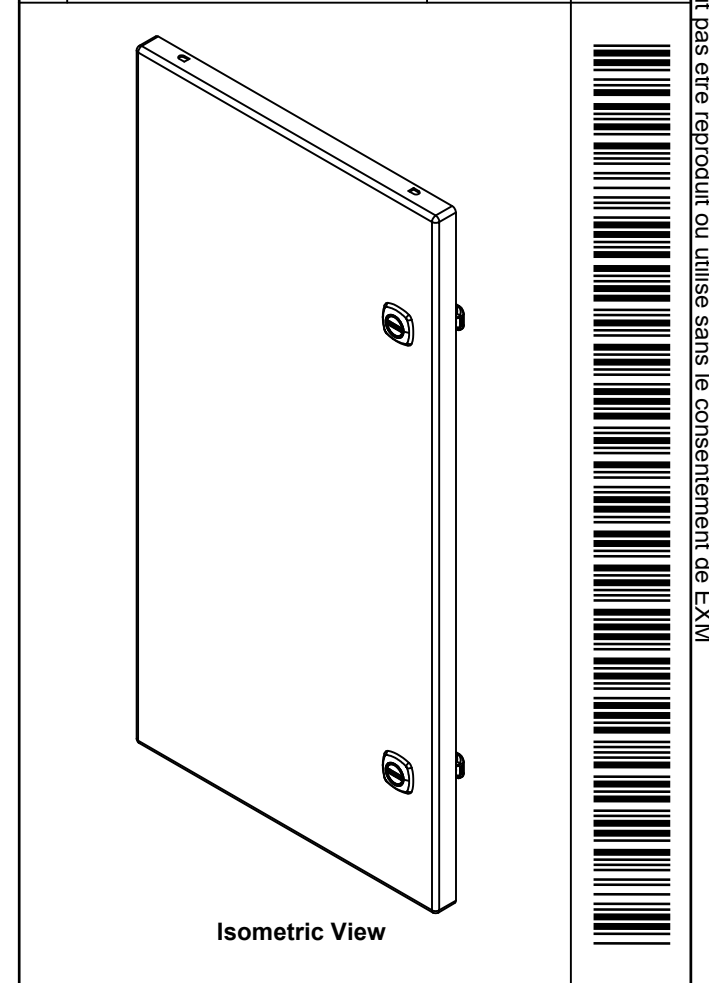

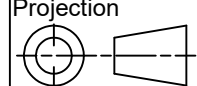
|  |                           |   |
|--|---------------------------|---|
|  Tél: (450) 979-4373<br>Fax: (450) 979-4626<br><a href="http://www.exmweb.com">www.exmweb.com</a> |                           | Flatness<br>Aplatissement<br>Max 3.0mm<br>Projection<br> |
| Customer<br>Client   | Date                      |   |
| Drawn By<br>Dessiné Par  | BoxCad: BoxCad            | Date 12-Feb-14  |
| Material<br>Matière  | 16 Ga H.R.P. & O. (1.4mm) |   |
| Color<br>Couleur   | Asa-61 Grey               | Finish<br>Fini Smooth   |
| Description  |                           | Detail Rev.   |
| 5412ESFM 24" x 12" Cover   |                           |   |
| Part Number<br>Numéro Pièce  | Rev.                      | 3   |
| <b>5412ESFM241206C</b>   | <b>0</b>                  | <b>3</b>  |

| Qty        | Part Name         | Rev | Description                             |
|------------|-------------------|-----|---|
| 1          | STK-S-00100       | 0   | 3.5" x 2" Silver Milar Flexcon Sticker  |
| 1          | STK-P-02400S      | 0   | Powder Paint (Asa-61 Grey / Smooth)     |
| 2          | STK-Q-46020-24    | 5   | 5412 ES Vertical Door Stiffener 24"     |
| 4          | STK-Q-16055       | 1   | M6 x 18mm Stud (No Paint Cap Required)  |
| 1          | 5412ESFM241206G   | 0   | 5412ESFM 24" x 12" Cover Gasket Part    |
| 1          | 5412ESFM241206C-P | 0   | 5412ESFM 24" x 12" Cover Part           |
| 2          | STK-K-09800       | 10  | 5412 ES Hinge with 2 Captive Hinge Pins |
| 2          | 880 SCQ4-SL       | 6   | 5412 ES 1/4 Turn Lock                   |
| 4          | STK-Q-07220       | 1   | M6 Nylon Insert Lock Nut                |
| Parts List |                   |     |   |

This drawing is confidential and must not be reproduced or used without the consent of EXM

Ce dessin est confidentiel et ne doit pas être reproduit ou utilisé sans le consentement de EXM

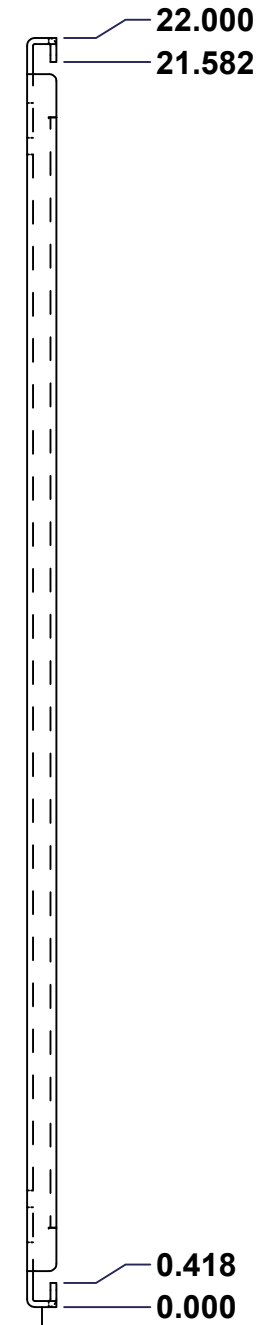
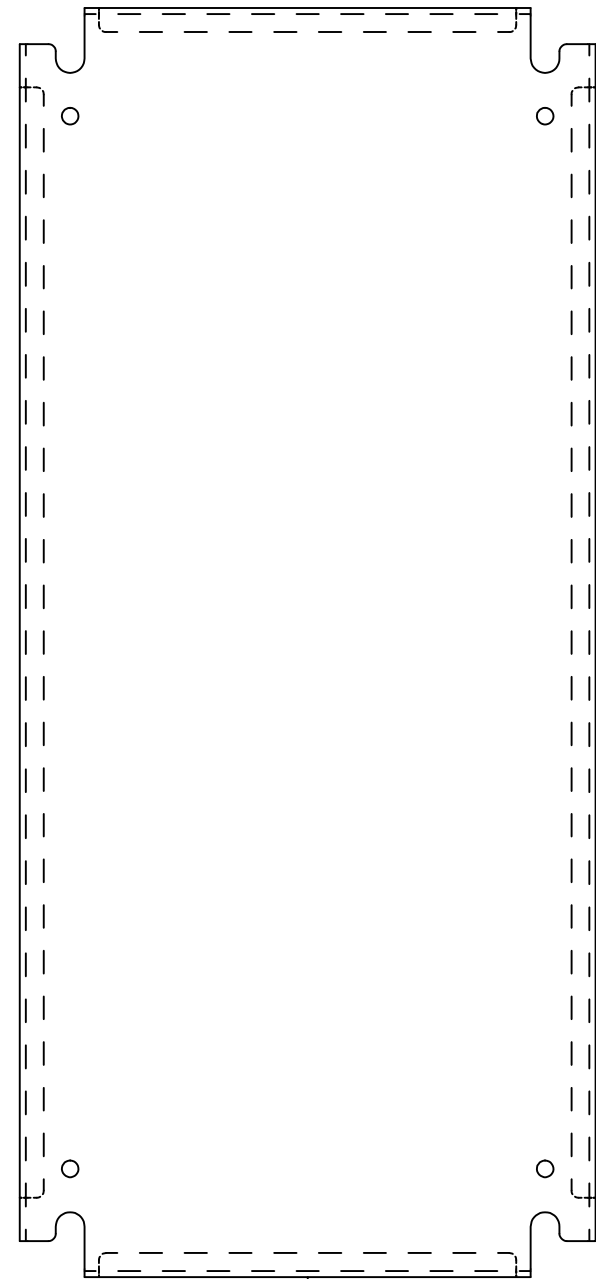
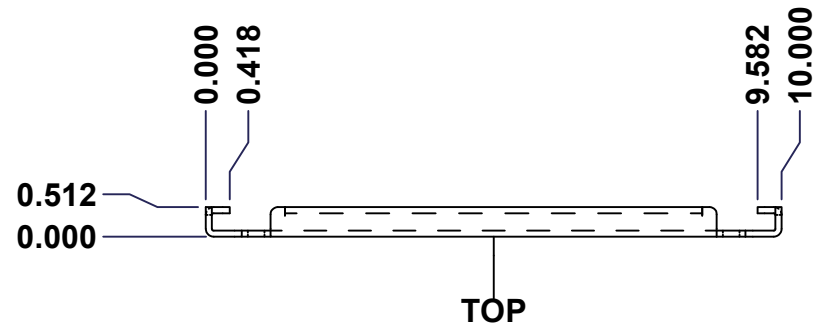

| No. | Revisions | Date | By/Par |
|-----|-----------|------|--------|
|     |           |      |        |
|     |           |      |        |
|     |           |      |        |
|     |           |      |        |
|     |           |      |        |

**Isometric View**

|  |  |                              |                    |
|--|--|------------------------------|--------------------|
| Tél: (450) 979-4373<br>Fax: (450) 979-4626<br>www.exmweb.com |  | Flatness<br>Aplatissement    |                    |
|  |  | Max 3.0mm<br>Projection      |                    |
| Customer<br>Client   |  | Date                         |                    |
| Drawn By<br>Dessiné Par BoxCad                               |  | Date 1/23/2007               |                    |
| Material<br>Matière See Part List                            |  |                              |                    |
| Color<br>Couleur See Part List                               |  | Finish<br>Fini See Part List |                    |
| Description<br>881 SP - Inner Panel                          |  |                              | Detail Rev.        |
| Part Number<br>Numéro Pièce <b>881 SP2412G</b>               |  |                              | Rev. 1<br><b>0</b> |

| Qty | Part Number   | Rev | Description               | Material         | Color     | Finish     |
|-----|---------------|-----|---------------------------|------------------|-----------|------------|
| 1   | 881 SP2412G-P | 0   | 881 SP - Inner Panel Part | 12 Ga Galvanized | Unpainted | Galvanized |

Parts List

This drawing is confidential and must not be reproduced or used without the consent of EXM

Ce dessin est confidentiel et ne doit pas être reproduit ou utilisé sans le consentement de EXM

| Table 1 |       |        | FRONT VIEW               |
|---------|-------|--------|--------------------------|
| CUT-OUT | XDIM  | YDIM   | DESCRIPTION              |
| 1       | 0.875 | 1.875  | GROUND HOLE (RND Ø0.290) |
| 2       | 9.125 | 1.875  | GROUND HOLE (RND Ø0.290) |
| 3       | 0.875 | 20.125 | GROUND HOLE (RND Ø0.290) |
| 4       | 9.125 | 20.125 | GROUND HOLE (RND Ø0.290) |

All knockouts are actual size / Les disques défonçables sont grandeur réel

| No. | Revisions | Date | By/Par |
|-----|-----------|------|--------|
|     |           |      |        |
|     |           |      |        |
|     |           |      |        |
|     |           |      |        |
|     |           |      |        |

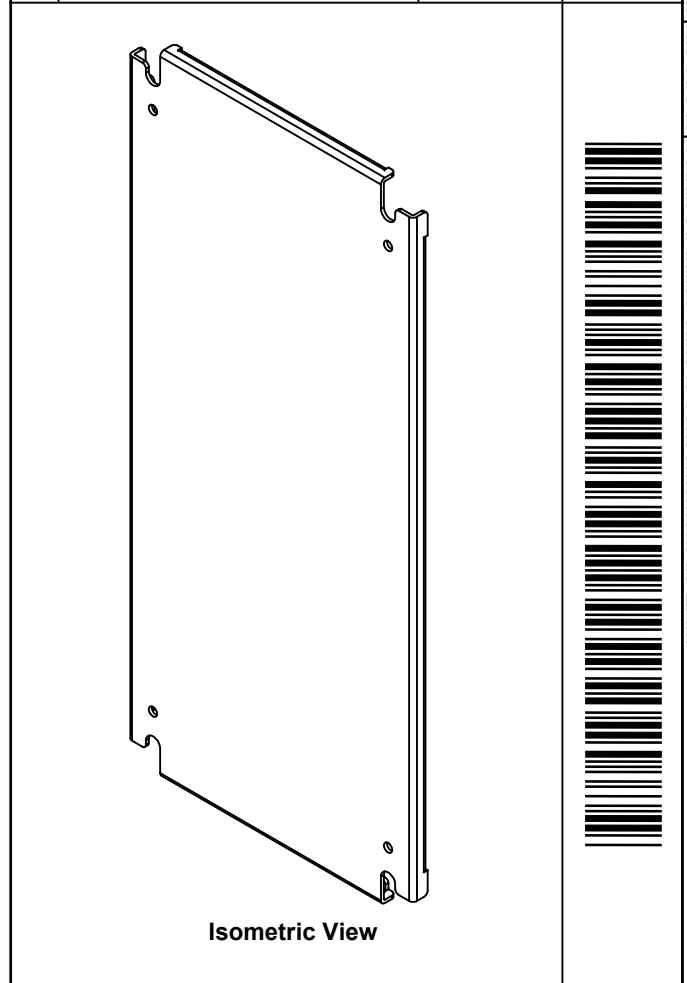
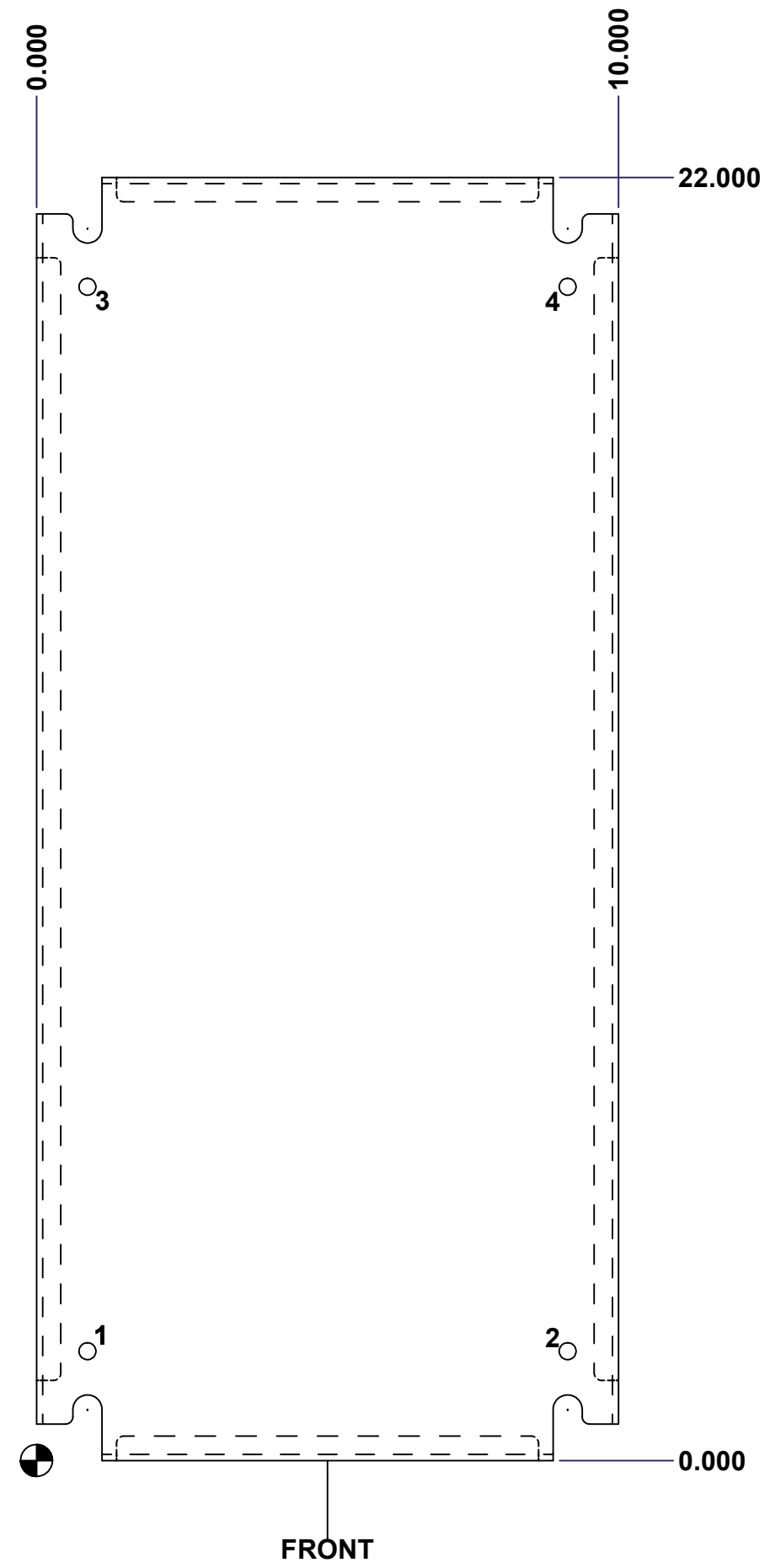

|  |  |                           |
|--|--|---------------------------|
| Tél: (450) 979-4373<br>Fax: (450) 979-4626<br>www.exmweb.com                         |  | Flatness<br>Aplatissement |
|  |  | Max 3.0mm                 |
| Customer Client<br>Drawn By / Dessiné Par: BoxCad<br>Material Matière: See Part List |  | Projection<br>            |
|  |  | Date: 1/23/2007           |
| Color Couleur: See Part List<br>Finish Fini: See Part List                           |  | Detail Rev.               |
| Description: 881 SP - Inner Panel  |  |                           |
| Part Number / Numéro Pièce: <b>881 SP2412G</b>                                       |  | Rev. 2<br><b>0</b>        |