

This drawing is confidential and must not be reproduced or used without the consent of EXM

Ce dessin est confidentiel et ne doit pas être reproduit ou utilisé sans le consentement de EXM

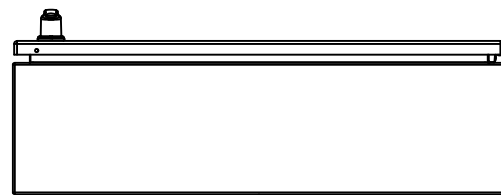

TOP

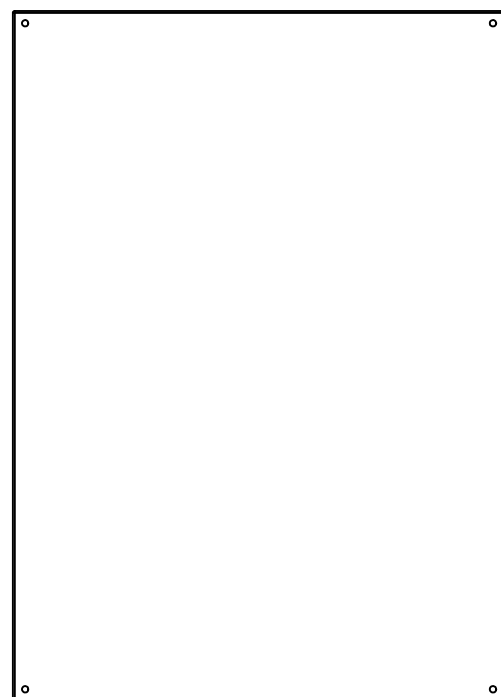

BACK

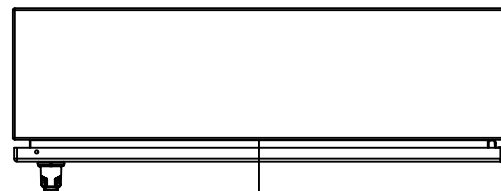

BOTTOM

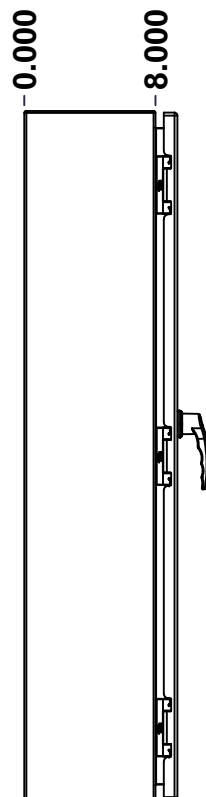

LEFT

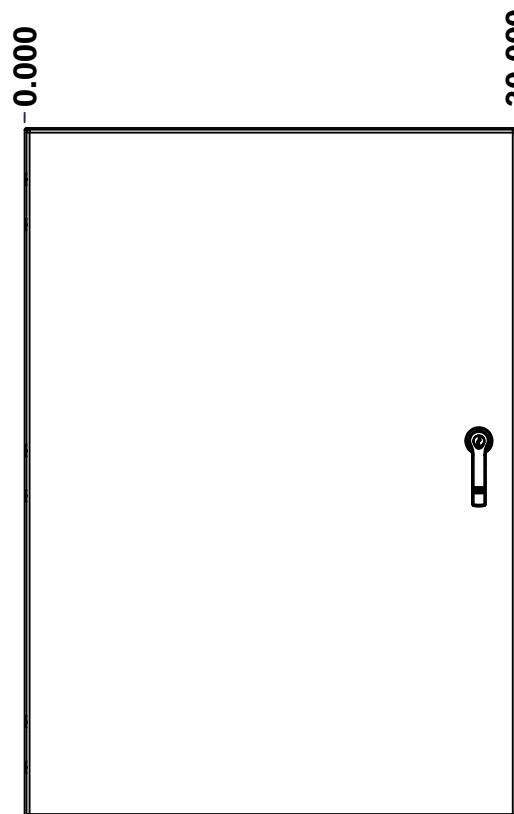

FRONT

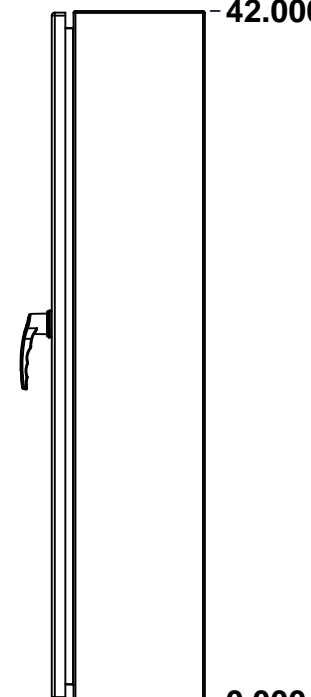

RIGHT

No.	Revisions	Date	By/Par

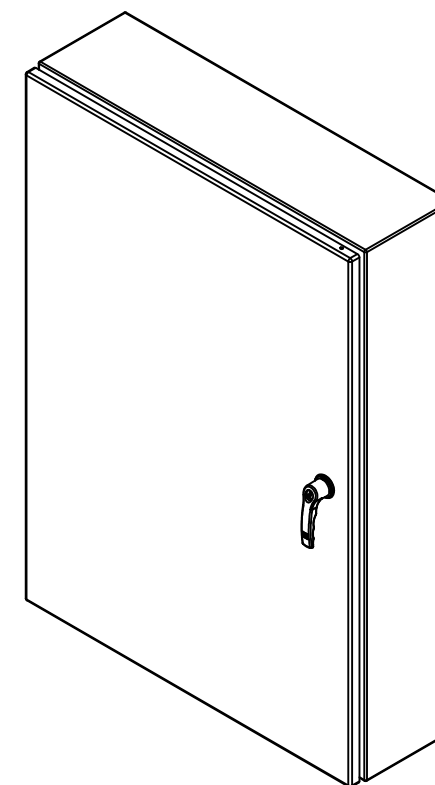

Isometric View



Tél: (450) 979-4373
 Fax: (450) 979-4626
www.exmweb.com

Flatness
Aplatissement

Max 3.0mm

Projection



Customer Client	Date
Drawn By / Dessiné Par: BoxCad: BoxCad	Date: 21-Apr-14

Material / Matière: 12 Ga H.R.P. & O. (2.5mm)

Color / Couleur: Asa-61 Grey	Finish / Fini: Smooth
------------------------------	-----------------------

Description: 5412ESHD 42" x 30" x 8" Assembly	Detail Rev.
---	-------------

Part Number / Numéro Pièce: 5412ESHD423008	Rev. 1	2
	0	

SEE BILL OF MATERIAL ON LAST PAGE

This drawing is confidential and must not be reproduced or used without the consent of EXM

Ce dessin est confidentiel et ne doit pas être reproduit ou utilisé sans le consentement de EXM

NOTE	
ITEM	DESCRIPTION
1	NEMA 4/12 Enclosure
2	C/W Standard ground studs on box and cover
3	C/W Standard door stiffener
4	C/W Standard inner panel (Included)
5	C/W Standard inner panel mounting studs

No.	Revisions	Date	By/Par

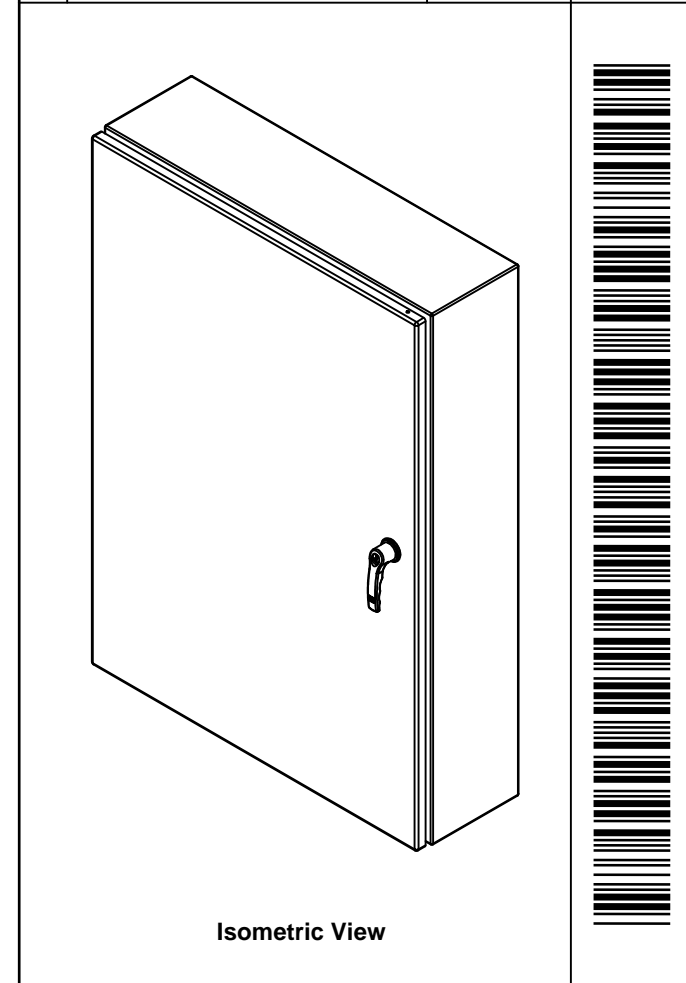

EXM
www.exm.com

Tél: (450) 979-4373
Fax: (450) 979-4626
www.exmweb.com

Flatness
Aplatissement
Max 3.0mm
Projection

Customer Client
Date

Drawn By Dessiné Par BoxCad: BoxCad
Date 21-Apr-14

Material Matière 12 Ga H.R.P. & O. (2.5mm)

Color Couleur Asa-61 Grey
Finish Fini Smooth

Description 5412ESHD 42" x 30" x 8" Assembly
Detail Rev.

Part Number Numéro Pièce **5412ESHD423008**
Rev. 0

PACKING		
ITEM	QTY	DESCRIPTION
Cardboard sleeve	2	Top and Bottom
Cardboard strip	2	Between back of enclosure and inner panel
Plastic bag	1	To protect cover surface and inside gasket
Cardboard corner	4	To reinforced for the plastic strap tightening
Plastic strap - Black	2	To Squeeze the 2 cardboard sleeve together
Packaging label	3	White label with PN
Plastic strap- Green	2	To secure the enclosure to the wood pallet
Wood Pallet	1	2" deeper and 3" larger than enclosure size

Qty	Part Number	Rev	Description
1	STK-K-01800	5	5412 ES Accessory Kit
1	880 PP	6	Self Adhesive Print Pocket
1	885SP4230G	0	885SP 42" x 30" Inner Panel Part
1	5412ESHD423008C	0	5412ESHD 42" x 30" Cover
6	STK-Q-07310	2	Flange Lock Nut M8
6	STK-Q-07610	8	M8 Plastic Spacer 22.2mm
1	5412ESHD423008B	0	5412ESHD 42" x 30" x 8" Body
3	STK-Q-04050-10	8	M6 x 10mm Hexagon Socket Head Machine Screw with Nyseal
Parts List			

This drawing is confidential and must not be reproduced or used without the consent of EXM

Ce dessin est confidentiel et ne doit pas être reproduit ou utilisé sans le consentement de EXM

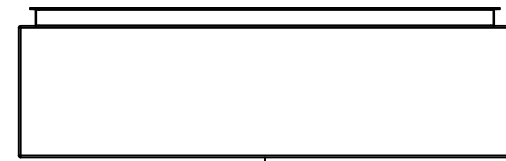

TOP

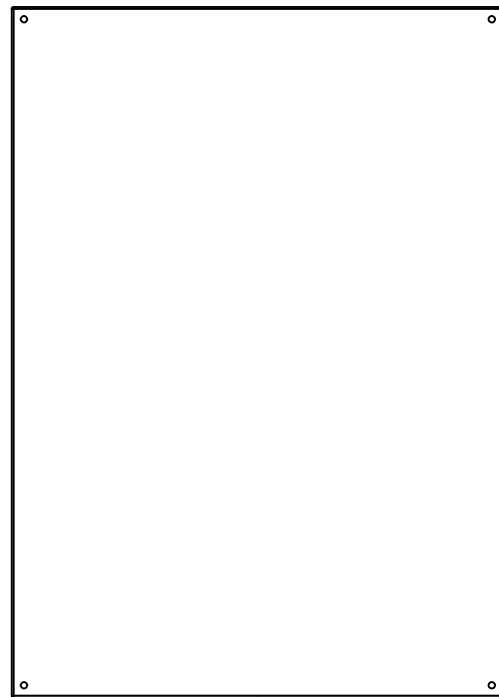

BACK

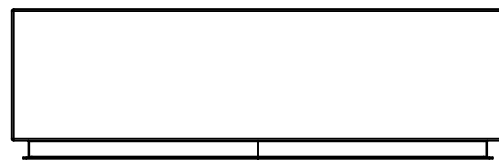

BOTTOM

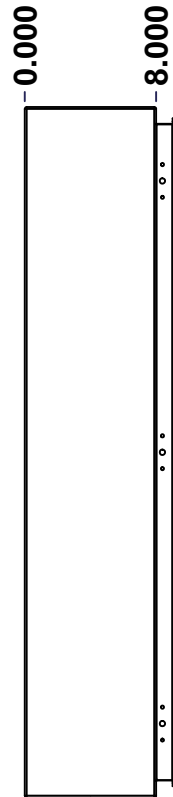

LEFT

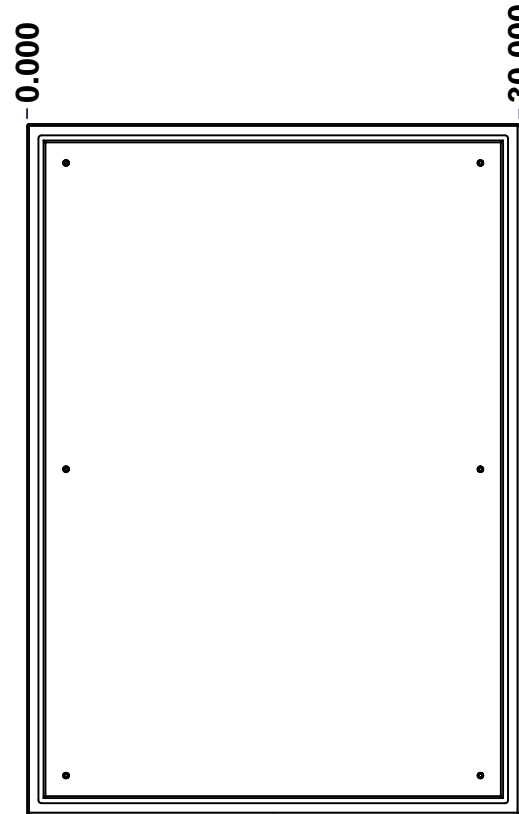

FRONT

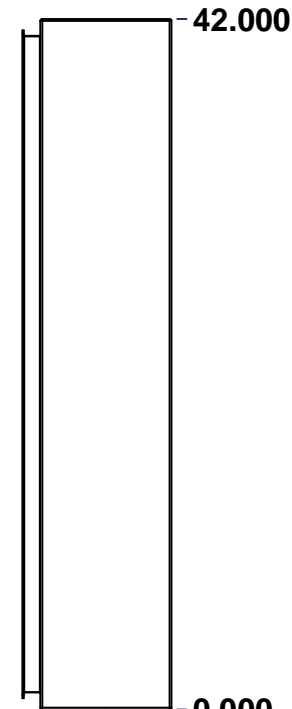

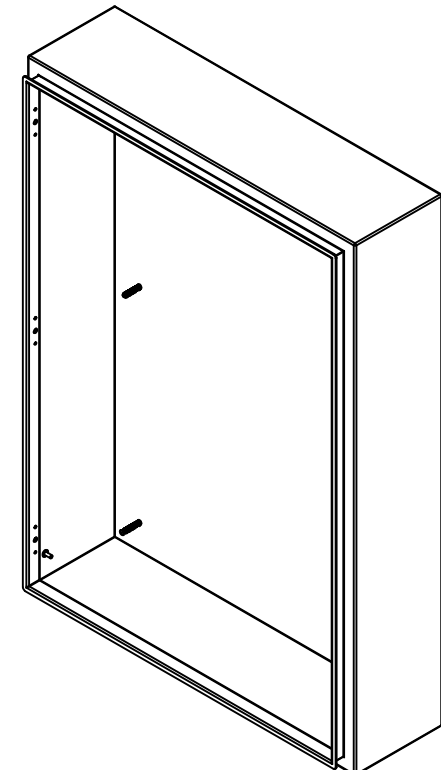

RIGHT



Isometric View

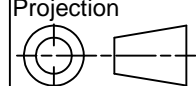

No.	Revisions	Date	By/Par

 Tél: (450) 979-4373 Fax: (450) 979-4626 www.exmweb.com		Flatness Aplatissement  Max 3.0mm Projection 
Customer Client	Date	
Drawn By / Dessiné Par: BoxCad: BoxCad	Date: 21-Apr-14	
Material / Matière: 12 Ga H.R.P. & O. (2.5mm)		
Color / Couleur: Asa-61 Grey	Finish / Fini: Smooth	
Description: 5412ESHD 42" x 30" x 8" Body	Detail Rev.	
Part Number / Numéro Pièce: 5412ESHD423008B	Rev. 0	1 / 7

SEE BILL OF MATERIAL ON LAST PAGE

This drawing is confidential and must not be reproduced or used without the consent of EXM

Ce dessin est confidentiel et ne doit pas être reproduit ou utilisé sans le consentement de EXM

STANDARD FEATURES ARE NOT LISTED IN THIS HOLE TABLE			
HOLE TABLE - LEFT VIEW (CUSTOM FEATURE ONLY)			
CUT-OUT	XDIM	YDIM	DESCRIPTION
1	6.500	2.000	GND STUD M6 x 16mm (Inside)

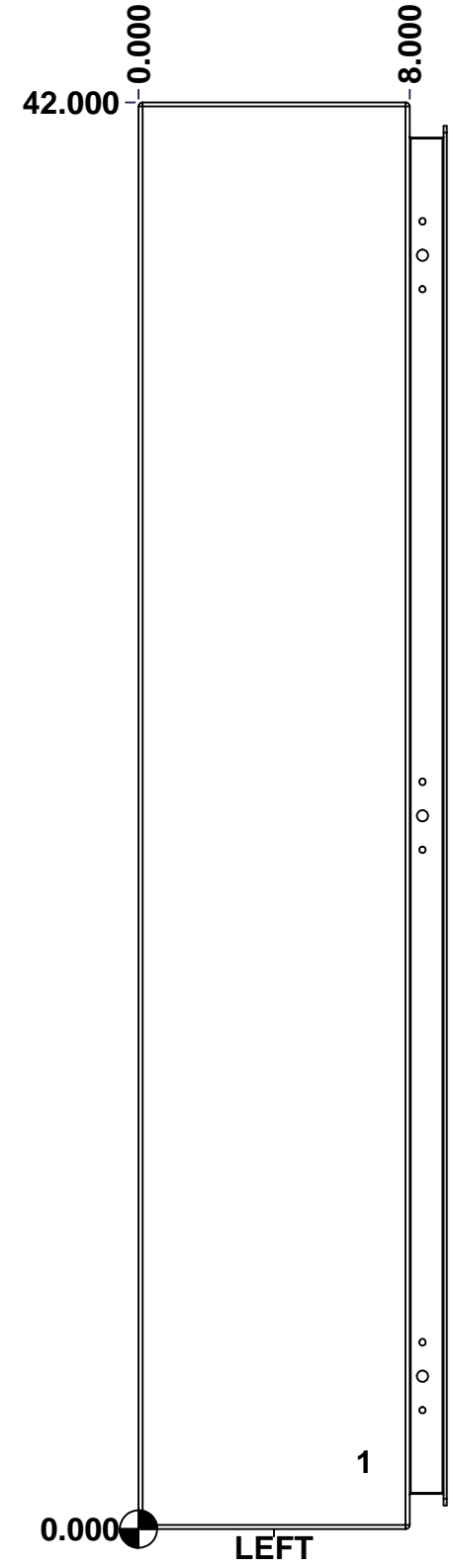

	Description	Status	
	5412ESHD 42" x 30" x 8" Body		
	Part Number Numéro Pièce	Rev.	5 / 7
	5412ESHD423008B	0	

This drawing is confidential and must not be reproduced or used without the consent of EXM

Ce dessin est confidentiel et ne doit pas être reproduit ou utilisé sans le consentement de EXM

STANDARD FEATURES ARE NOT LISTED IN THIS HOLE TABLE

HOLE TABLE - BACK VIEW (CUSTOM FEATURE ONLY)

CUT-OUT	XDIM	YDIM	DESCRIPTION
1	2.375	2.375	IP STUD M8 x 35mm (Inside)
2	2.375	39.625	IP STUD M8 x 35mm (Inside)
3	27.625	39.625	IP STUD M8 x 35mm (Inside)
4	27.625	2.375	IP STUD M8 x 35mm (Inside)
5	2.375	21.000	IP STUD M8 x 35mm (Inside)
6	27.625	21.000	IP STUD M8 x 35mm (Inside)

7	29.250	0.750	RND Ø0.390
8	29.250	41.250	RND Ø0.390
9	0.750	41.250	RND Ø0.390
10	0.750	0.750	RND Ø0.390

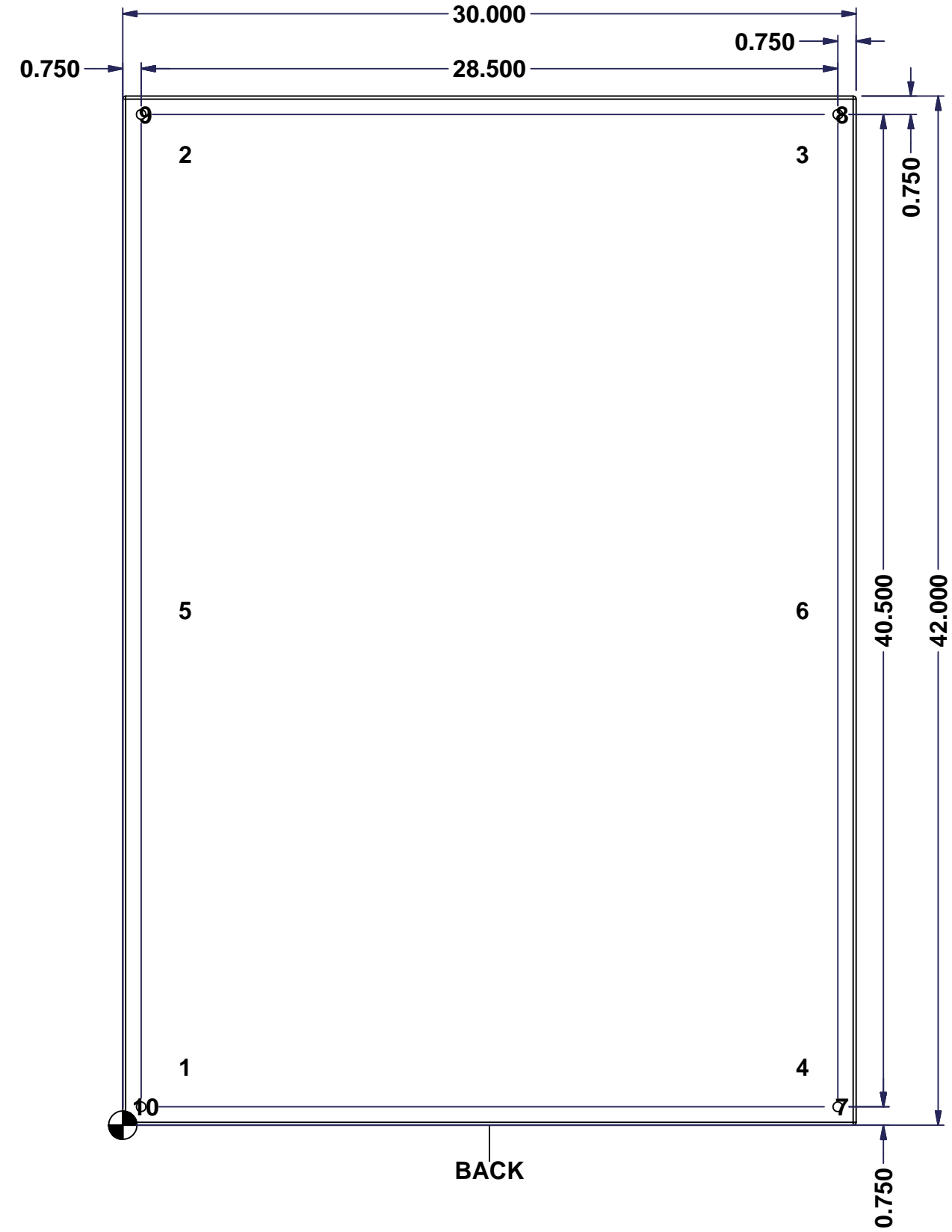

BACK

	Description	Status	
	5412ESHD 42" x 30" x 8" Body		
	Part Number Numéro Pièce	Rev.	6
	5412ESHD423008B	0	7

This drawing is confidential and must not be reproduced or used without the consent of EXM

Ce dessin est confidentiel et ne doit pas être reproduit ou utilisé sans le consentement de EXM

No.	Revisions	Date	By/Par

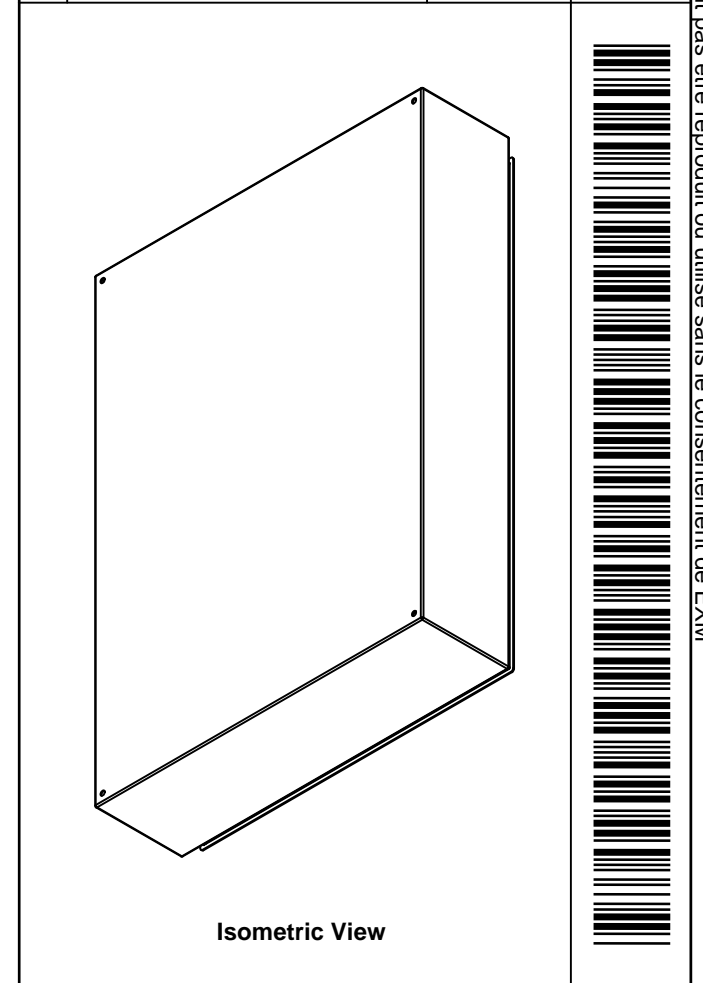

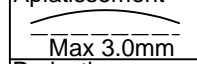
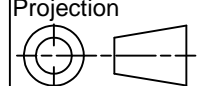
 Tél: (450) 979-4373 Fax: (450) 979-4626 www.exmweb.com		Flatness Aplatissement  Max 3.0mm Projection 
Customer Client	Date	
Drawn By Dessiné Par	BoxCad: BoxCad	Date 21-Apr-14
Material Matière	12 Ga H.R.P. & O. (2.5mm)	
Color Couleur	Asa-61 Grey	Finish Fini Smooth
Description		Detail Rev.
5412ESHD 42" x 30" x 8" Body		
Part Number Numéro Pièce	Rev.	7
5412ESHD423008B	0	7

Qty	Part Number	Rev	Description
1	STK-Q-16080	0	Ground Stud M6 x 16mm
1	STK-P-02400S	0	Powder Paint (Asa-61 Grey / Smooth)
6	STK-Q-16005	1	Stud M8 x 35 (No Paint Cap Required)
1	5412ESHD423008B-P	0	5412ESHD 42" x 30" x 8" Body Part
Parts List			

This drawing is confidential and must not be reproduced or used without the consent of EXM

Ce dessin est confidentiel et ne doit pas être reproduit ou utilisé sans le consentement de EXM

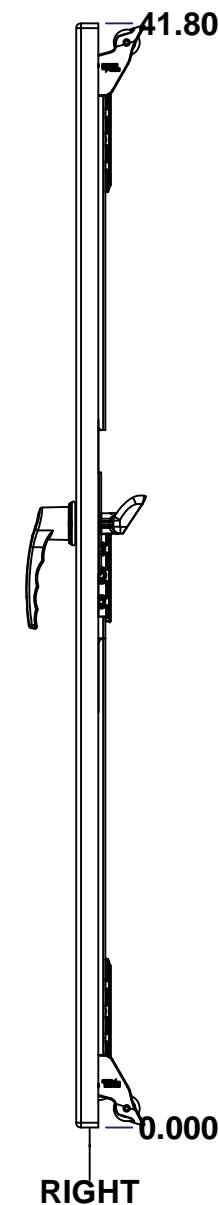
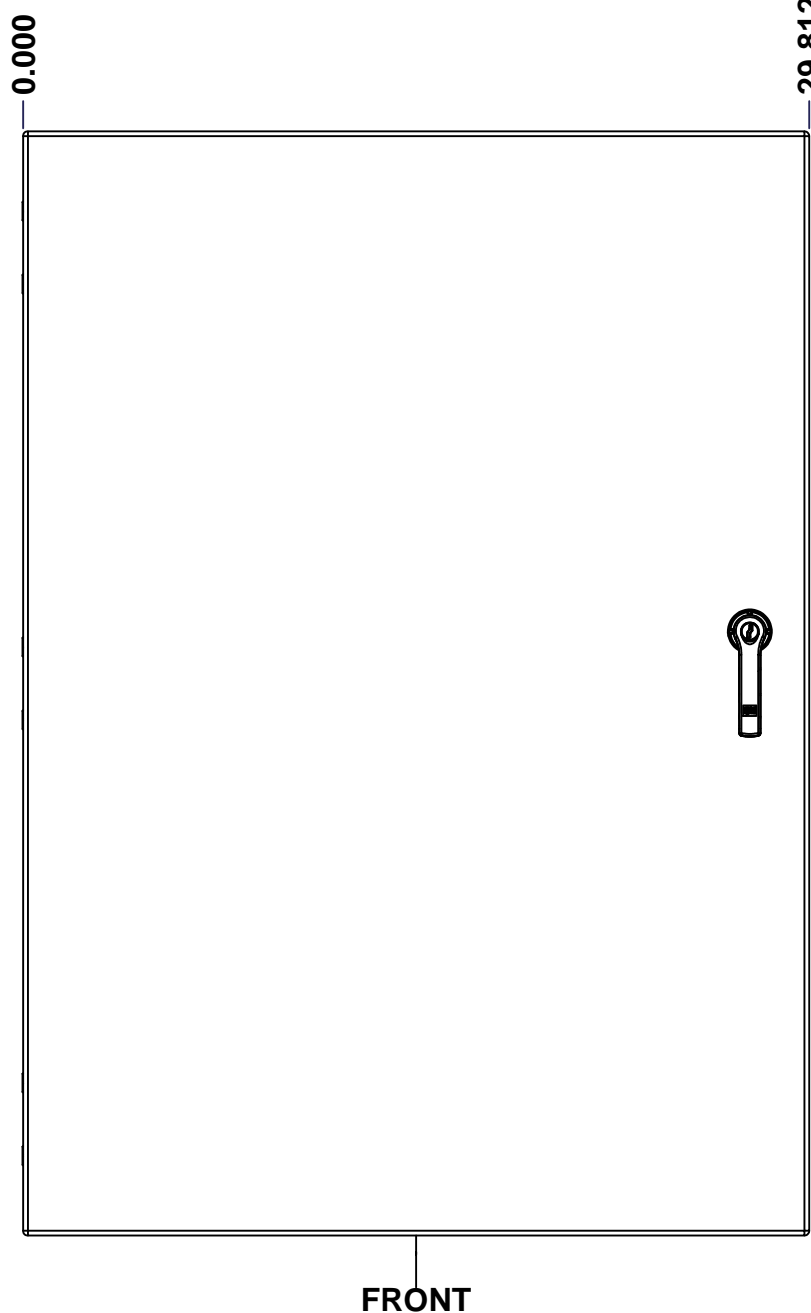
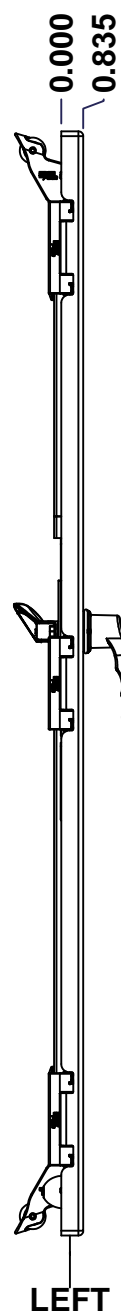
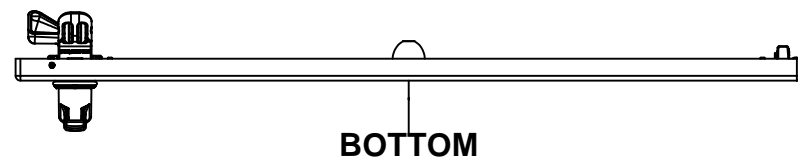
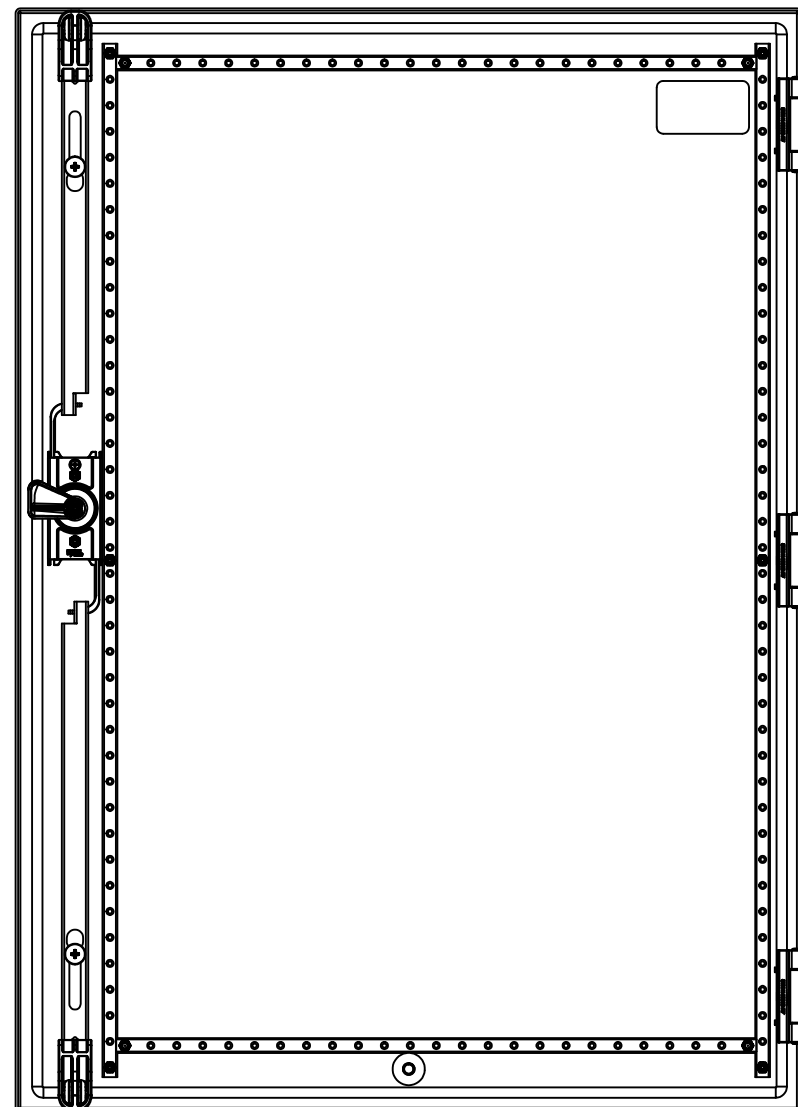
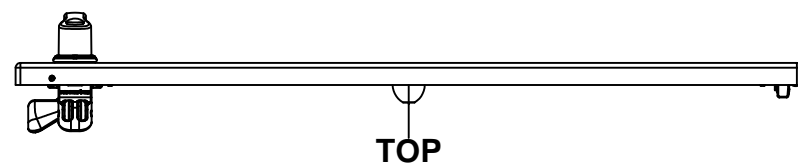

No.	Revisions	Date	By/Par

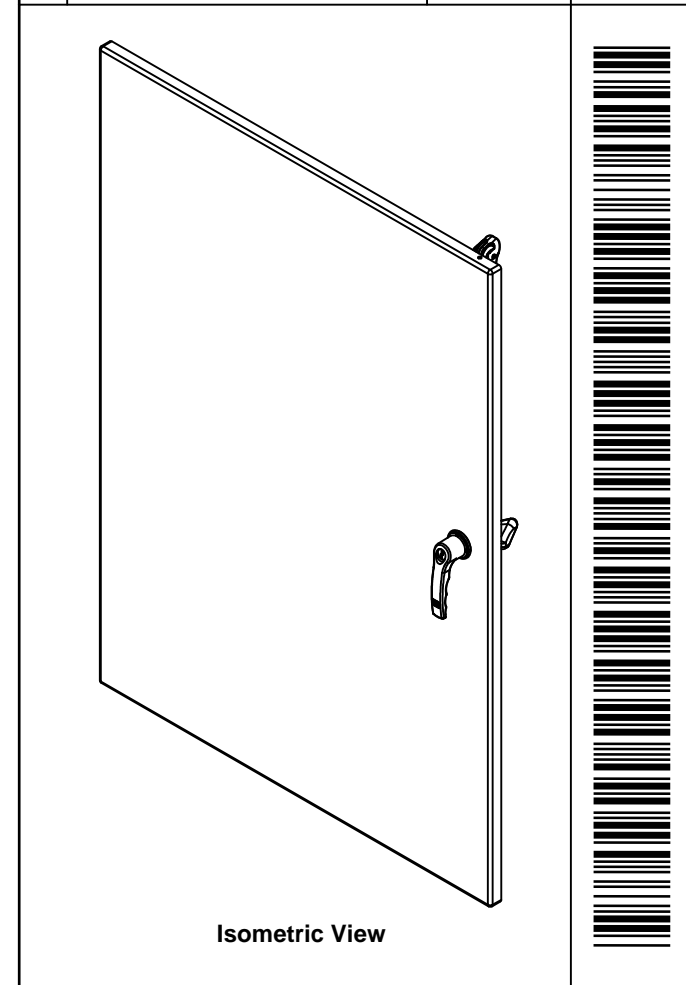

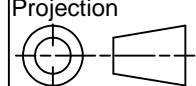
 Tél: (450) 979-4373 Fax: (450) 979-4626 www.exmweb.com		Flatness Aplatissement	
		Max 3.0mm	
Customer Client		Date	
Drawn By Dessiné Par BoxCad: BoxCad		Date 21-Apr-14	
Material Matière 12 Ga H.R.P. & O. (2.5mm)		Projection	
Color Couleur Asa-61 Grey		 Finish Fini Smooth	
Description 5412ESHD 42" x 30" Cover		Detail Rev.	
Part Number Numéro Pièce 5412ESHD423008C		Rev. 0	1 3

SEE BILL OF MATERIAL ON LAST PAGE

This drawing is confidential and must not be reproduced or used without the consent of EXM

Ce dessin est confidentiel et ne doit pas être reproduit ou utilisé sans le consentement de EXM

STANDARD FEATURES ARE NOT LISTED IN THIS HOLE TABLE

HOLE TABLE - FRONT VIEW (CUSTOM FEATURE ONLY)

CUT-OUT	XDIM	YDIM	DESCRIPTION
1	1.486	1.709	STUD M6 x 18mm (Inside)
2	1.486	40.094	STUD M6 x 18mm (Inside)
3	26.236	40.094	STUD M6 x 18mm (Inside)
4	26.236	1.709	STUD M6 x 18mm (Inside)
5	1.486	20.902	STUD M6 x 18mm (Inside)
6	26.236	20.902	STUD M6 x 18mm (Inside)
7	2.050	2.537	STUD M6 x 18mm (Inside)
8	2.050	39.733	STUD M6 x 18mm (Inside)
9	25.672	39.733	STUD M6 x 18mm (Inside)
10	25.672	2.537	STUD M6 x 18mm (Inside)
11	27.563	35.803	STUD M6 x 18mm (Inside)
12	27.563	6.000	STUD M6 x 18mm (Inside)
13	27.563	21.620	GEARBOX STUD (Inside)
14	27.563	24.120	GEARBOX STUD (Inside)
15	14.906	1.650	STUD M6 x 18mm (Inside)

16	3.750	38.053	LABEL_EXM (Inside)
17	27.563	22.870	HANDLE 885 ESL2A @ 0.0°

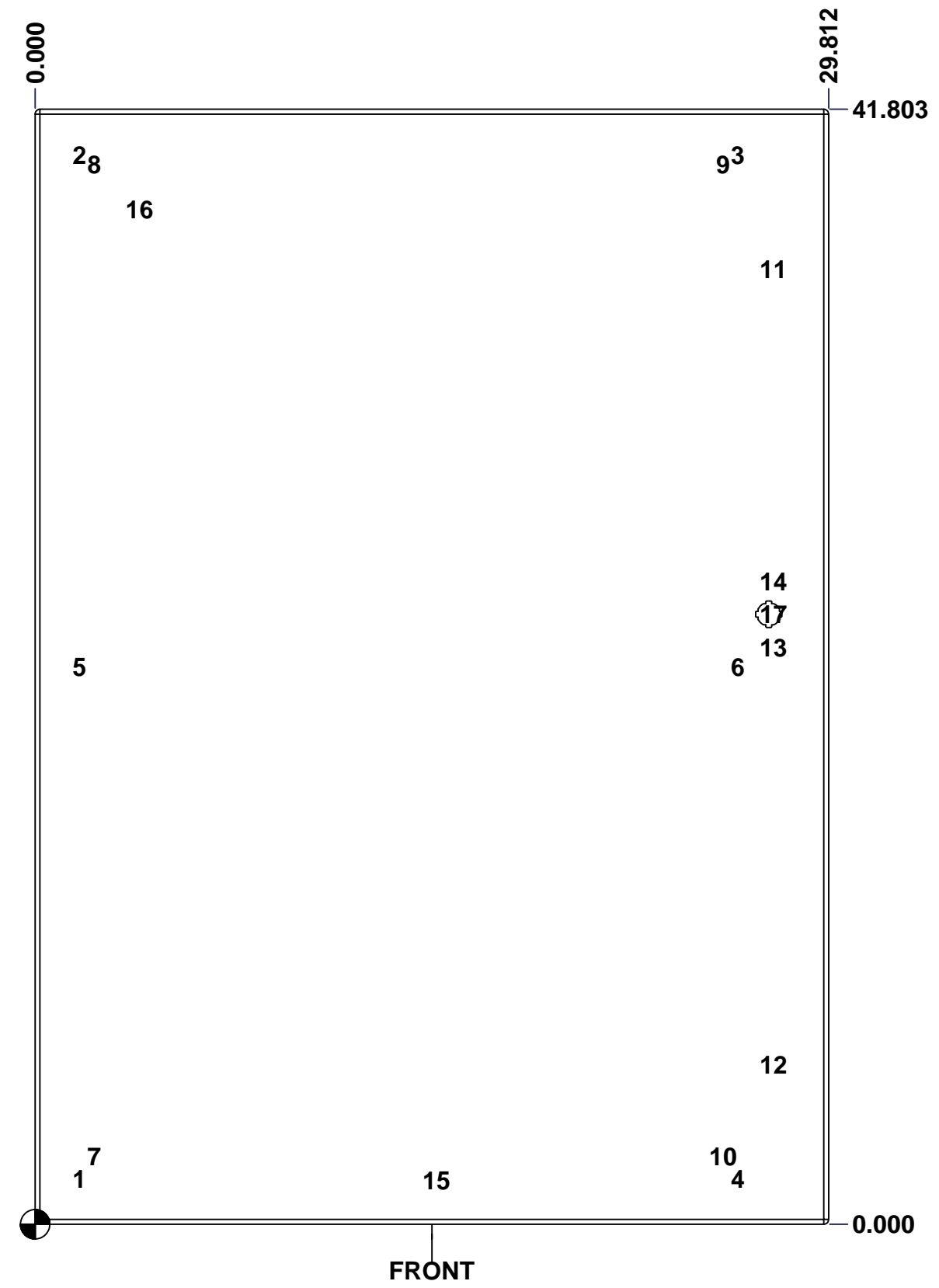

	Description	Status
	5412ESHD 42" x 30" Cover	(NULL)
	Part Number Numéro Pièce	Rev.
	5412ESHD423008C	0
		2
		3

This drawing is confidential and must not be reproduced or used without the consent of EXM

Ce dessin est confidentiel et ne doit pas être reproduit ou utilisé sans le consentement de EXM

No.	Revisions	Date	By/Par

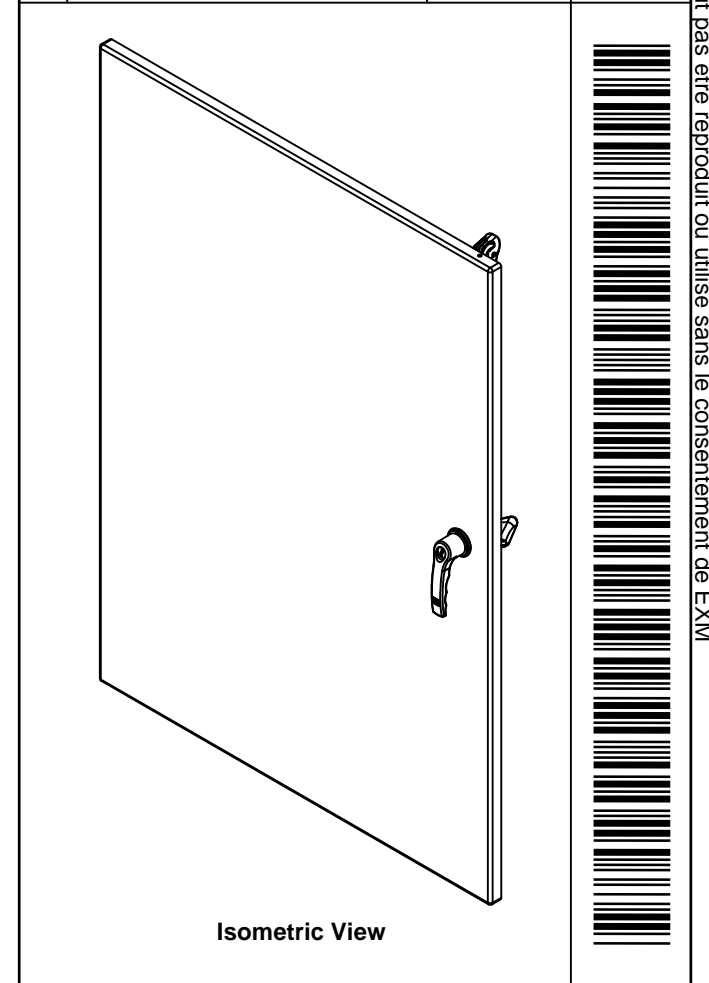

1	5412ESHD423008CB1_D	0	5412ESHD 42" Lower Closing Bar
1	5412ESHD423008CB1_U	0	5412ESHD 42" Upper Closing Bar
1	STK-A-03880-36	12	Gearbox Clockwise Assembly (Grip 36mm)
1	885 ESL2A	4	5412 ES Key Lock L-Handle (3 Pts)
1	STK-S-00100	0	3.5" x 2" Silver Milar Flexcon Sticker
1	STK-P-02400S	0	Powder Paint (Asa-61 Grey / Smooth)
1	STK-Q-46515	3	5412 ES Door Support with Brass Insert
2	STK-Q-46025-30-3	4	5412 ES Horizontal Door Stiffener 30" (3Pts)
2	STK-Q-46020-42	5	5412 ES Vertical Door Stiffener 42"
11	STK-Q-16055	1	M6 x 18mm Stud (No Paint Cap Required)
1	5412ESHD423008G	0	5412ESHD 42" x 30" Door Gasket
1	5412ESHD423008C-P	0	5412ESHD 42" x 30" Cover Part
3	STK-K-09860	7	Cabinet Hinge with Captive Pins
10	STK-Q-07220	1	M6 Nylon Insert Lock Nut
Qty	Part Name	Rev	Description
Parts List			

<p>Tél: (450) 979-4373 Fax: (450) 979-4626 www.exmweb.com</p>	Flatness Aplatissement
	Max 3.0mm
Projection	
Customer Client	Date
Drawn By Dessiné Par	Date 21-Apr-14
Material Matière	12 Ga H.R.P. & O. (2.5mm)
Color Couleur	Asa-61 Grey
Finish Fini	Smooth
Description	Detail Rev.
5412ESHD 42" x 30" Cover	
Part Number Numéro Pièce	Rev. 3
5412ESHD423008C	0 3

This drawing is confidential and must not be reproduced or used without the consent of EXM

Ce dessin est confidentiel et ne doit pas être reproduit ou utilisé sans le consentement de EXM

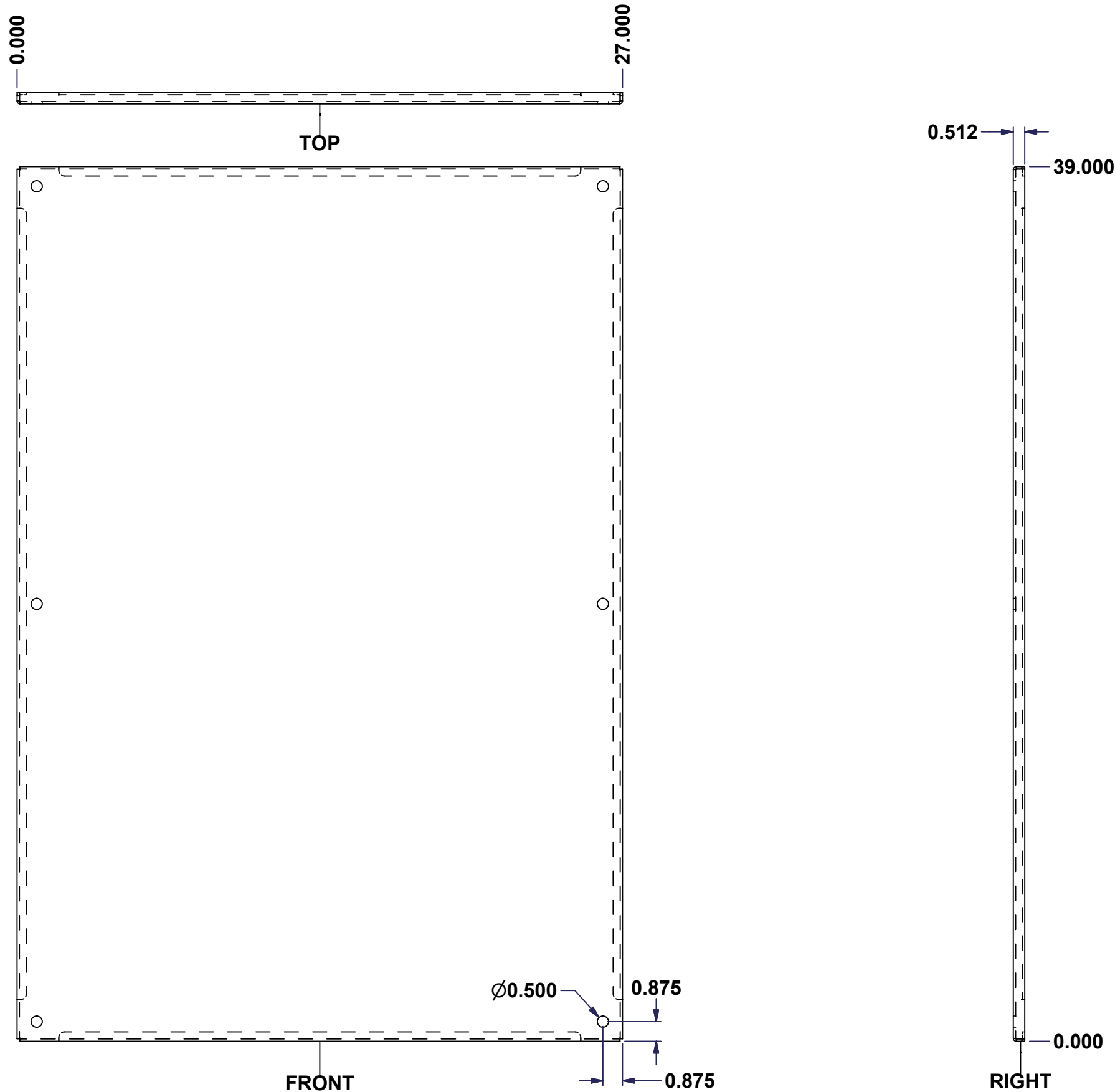

No.	Revisions	Date	By/Par

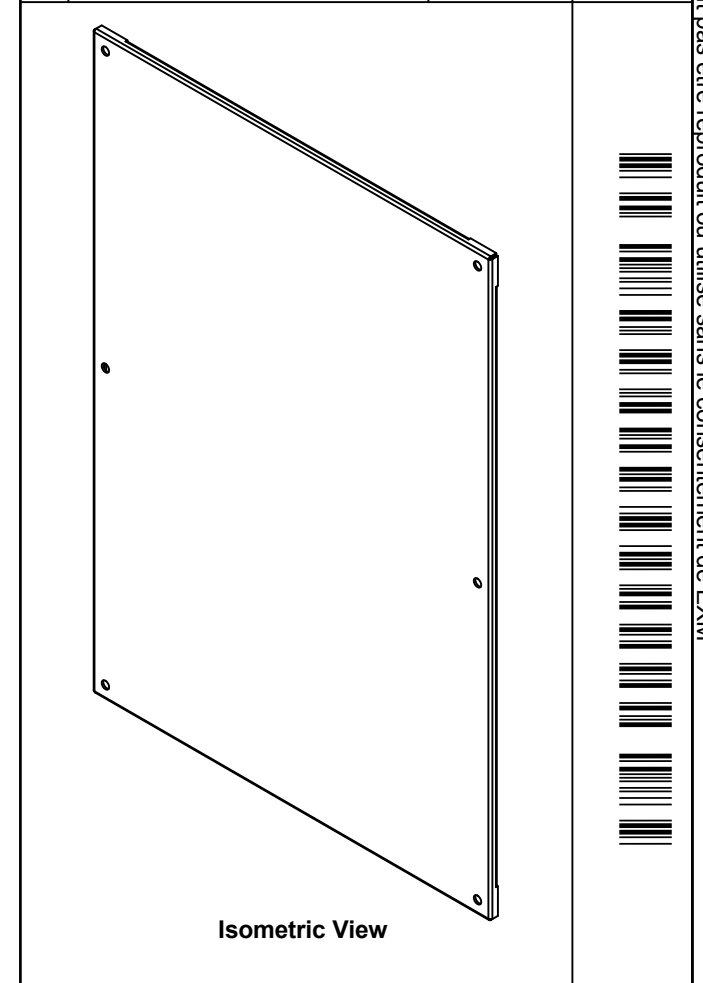

 Tél: (450) 979-4373 Fax: (450) 979-4626 www.exmweb.com		Flatness Aplatissement
		Max 3.0mm
Customer Client		Date
Drawn By Dessiné Par BoxCad: nickz		Date 01/03/2017
Material Matière 12 Ga Galvanized (2.5mm)		
Color Couleur See Part List	Finish Fini See Part List	
Description 885SP 42" x 30" Inner Panel Part		Detail Rev.
Part Number Numéro Pièce 885SP4230G		Rev. 1

Qty	Part Number	Rev	Description	Material	Color	Finish
1	885SP4230G-P	0	885SP 42" x 30" Inner Panel Part	12 Ga Galvanized (2.5mm)	Unpainted	Galvanized

Parts List