

This drawing is confidential and must not be reproduced or used without the consent of EXM

Ce dessin est confidentiel et ne doit pas être reproduit ou utilisé sans le consentement de EXM



TOP



BACK

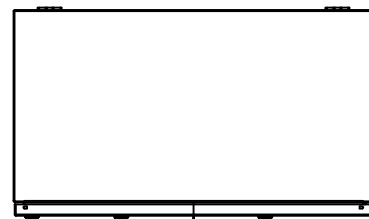

BOTTOM

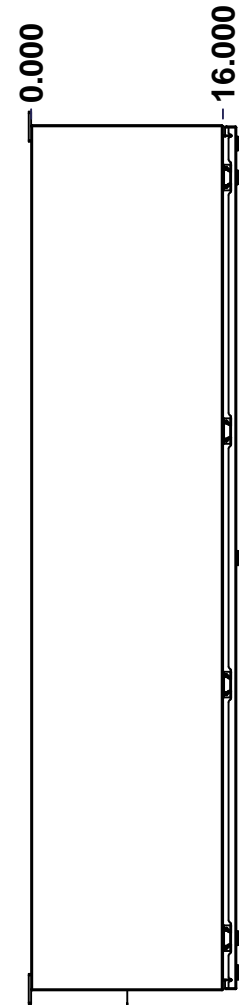

LEFT

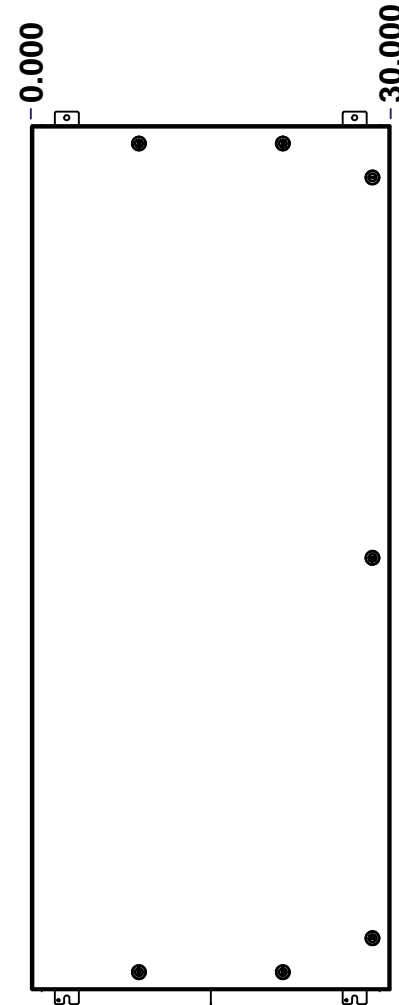

FRONT

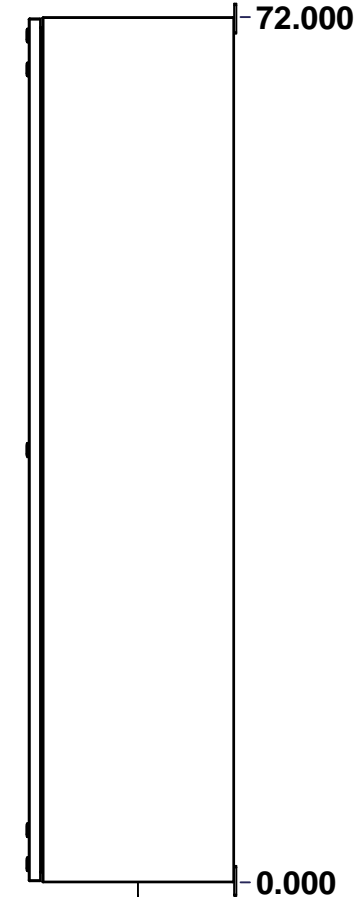

RIGHT

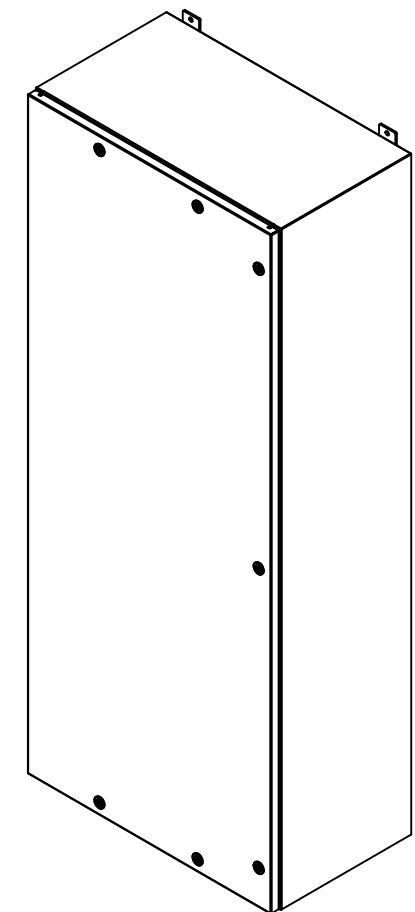

Isometric View

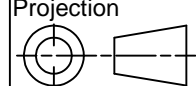

No.	Revisions	Date	By/Par

 Tél: (450) 979-4373 Fax: (450) 979-4626 <a href="http://www.exmweb.com">www.exmweb.com</a>		Flatness Aplatissement Max 3.0mm Projection 
Customer Client	Date	
Drawn By Dessiné Par	BoxCad: Annie	Date 15/04/2014
Material Matière	14 Ga H.R.P. & O. (1.7mm)	
Color Couleur	Asa-61 Grey	Finish Fini Smooth
Description	Detail Rev.	
5412ESPR 72" x 30" x 16" Assembly		
Part Number Numéro Pièce	Rev. 0	1 2
<b>5412ESPR723016</b>		

SEE BILL OF MATERIAL ON LAST PAGE

This drawing is confidential and must not be reproduced or used without the consent of EXM

Ce dessin est confidentiel et ne doit pas être reproduit ou utilisé sans le consentement de EXM

NOTE	
ITEM	DESCRIPTION
1	NEMA 4/12 Enclosure
2	C/W Standard ground studs on box and cover
3	W/O Standard door stiffener
4	C/W Standard inner panel (Sold seperately)
5	C/W Standard inner panel mounting studs

No.	Revisions	Date	By/Par

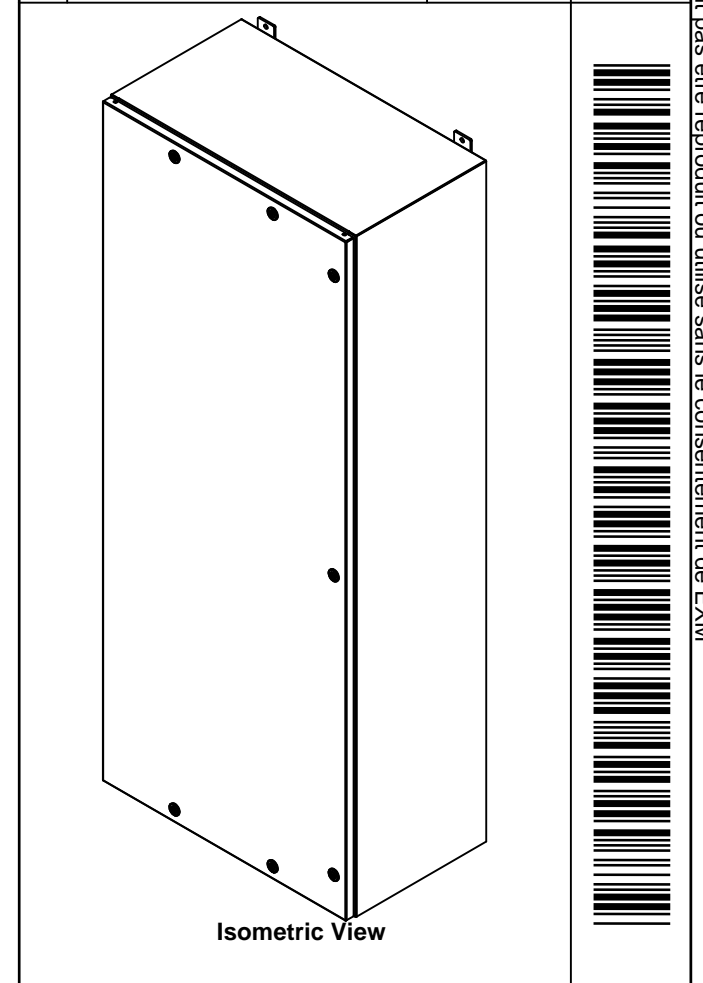

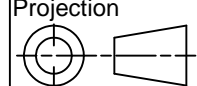
 Tél: (450) 979-4373 Fax: (450) 979-4626 <a href="http://www.exmweb.com">www.exmweb.com</a>		Flatness Aplatissement Max 3.0mm Projection 
Customer Client	Date	
Drawn By Dessiné Par	BoxCad: Annie	Date 15/04/2014
Material Matière	14 Ga H.R.P. & O. (1.7mm)	
Color Couleur	Asa-61 Grey	Finish Fini Smooth
Description		Detail Rev.
5412ESPR 72" x 30" x 16" Assembly		
Part Number Numéro Pièce	Rev. 0	2
<b>5412ESPR723016</b>		2

Qty	Part Number	Rev	Description
1	STK-K-01800	0	5412 ES Accessory Kit
8	STK-Q-03000	0	M5 x 8mm Phillips Flat Head Screw
1	881 SP7230	0	881 SP - Inner Panel
1	880 PP	0	Self Adhesive Print Pocket
1	5412ESPR723016C	0	5412ESPR 72" x 30" Cover
6	STK-Q-07310	2	Flange Lock Nut M8
6	STK-Q-07610	7	M8 Plastic Spacer 22.2mm
1	5412ESPR723016B	0	5412ESPR 72" x 30" x 16" Body
Parts List			

This drawing is confidential and must not be reproduced or used without the consent of EXM

Ce dessin est confidentiel et ne doit pas être reproduit ou utilisé sans le consentement de EXM

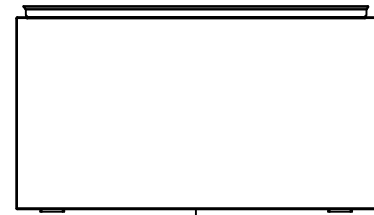

TOP

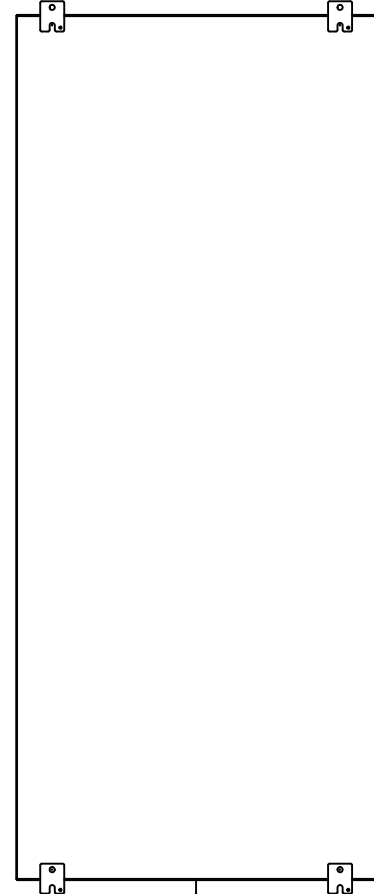

BACK

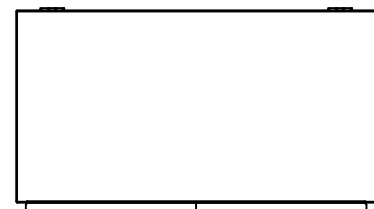

BOTTOM

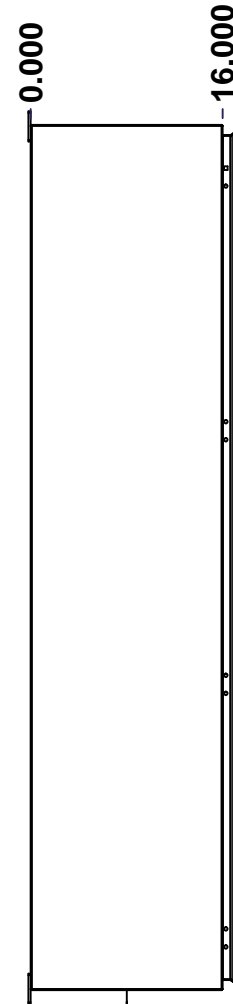

LEFT

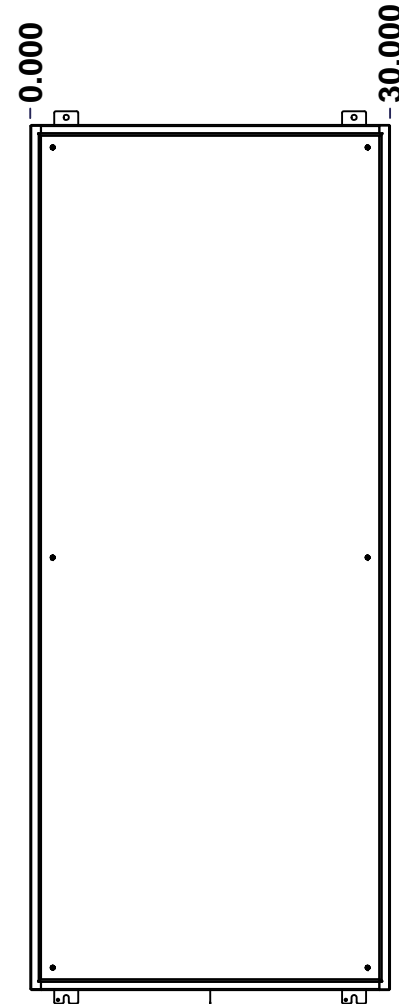

FRONT

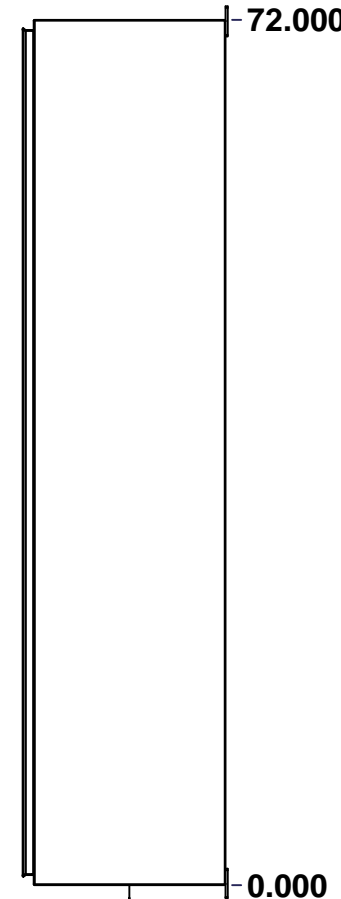

RIGHT

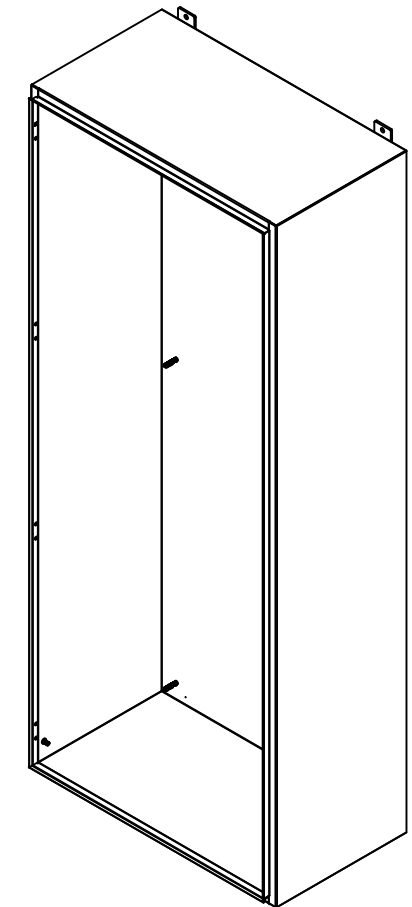

Isometric View

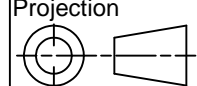

No.	Revisions	Date	By/Par

 Tél: (450) 979-4373 Fax: (450) 979-4626 <a href="http://www.exmweb.com">www.exmweb.com</a>		Flatness Aplatissement Max 3.0mm Projection 	
Customer Client		Date	
Drawn By Dessiné Par BoxCad: Annie		Date 15/04/2014	
Material Matière 14 Ga H.R.P. & O. (1.7mm)			
Color Couleur Asa-61 Grey		Finish Fini Smooth	
Description 5412ESPR 72" x 30" x 16" Body			Detail Rev.
Part Number Numéro Pièce <b>5412ESPR723016B</b>		Rev. <b>0</b>	1 7

SEE BILL OF MATERIAL ON LAST PAGE

This drawing is confidential and must not be reproduced or used without the consent of EXM

Ce dessin est confidentiel et ne doit pas être reproduit ou utilisé sans le consentement de EXM

STANDARD FEATURES ARE NOT LISTED IN THIS HOLE TABLE			
HOLE TABLE - LEFT VIEW (CUSTOM FEATURE ONLY)			
CUT-OUT	XDIM	YDIM	DESCRIPTION
1	14.500	2.000	GND STUD M6 x 16mm (Inside)

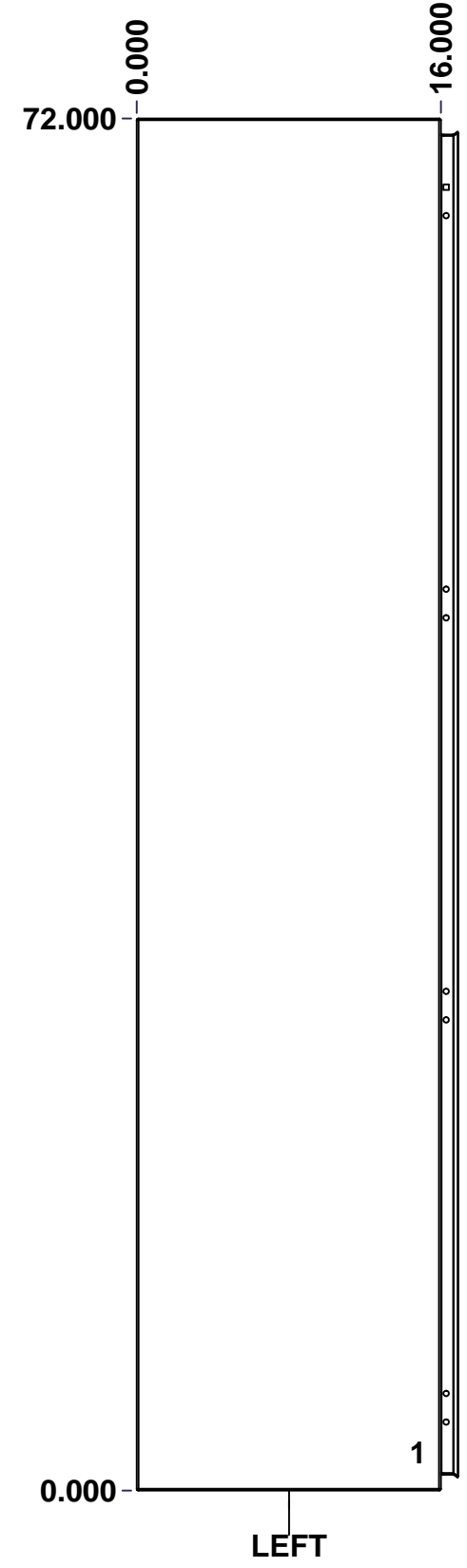

	Description	Status	
	5412ESPR 72" x 30" x 16" Body		
	Part Number Numéro Pièce	Rev.	
	<b>5412ESPR723016B</b>	<b>0</b>	5 / 7

This drawing is confidential and must not be reproduced or used without the consent of EXM

Ce dessin est confidentiel et ne doit pas être reproduit ou utilisé sans le consentement de EXM

**STANDARD FEATURES ARE NOT LISTED IN THIS HOLE TABLE**

**HOLE TABLE - BACK VIEW (CUSTOM FEATURE ONLY)**

CUT-OUT	XDIM	YDIM	DESCRIPTION
1	1.807	1.875	IP STUD M8 x 35mm (Inside)
2	1.807	70.125	IP STUD M8 x 35mm (Inside)
3	28.057	70.125	IP STUD M8 x 35mm (Inside)
4	28.057	1.875	IP STUD M8 x 35mm (Inside)
5	1.807	36.000	IP STUD M8 x 35mm (Inside)
6	28.057	36.000	IP STUD M8 x 35mm (Inside)

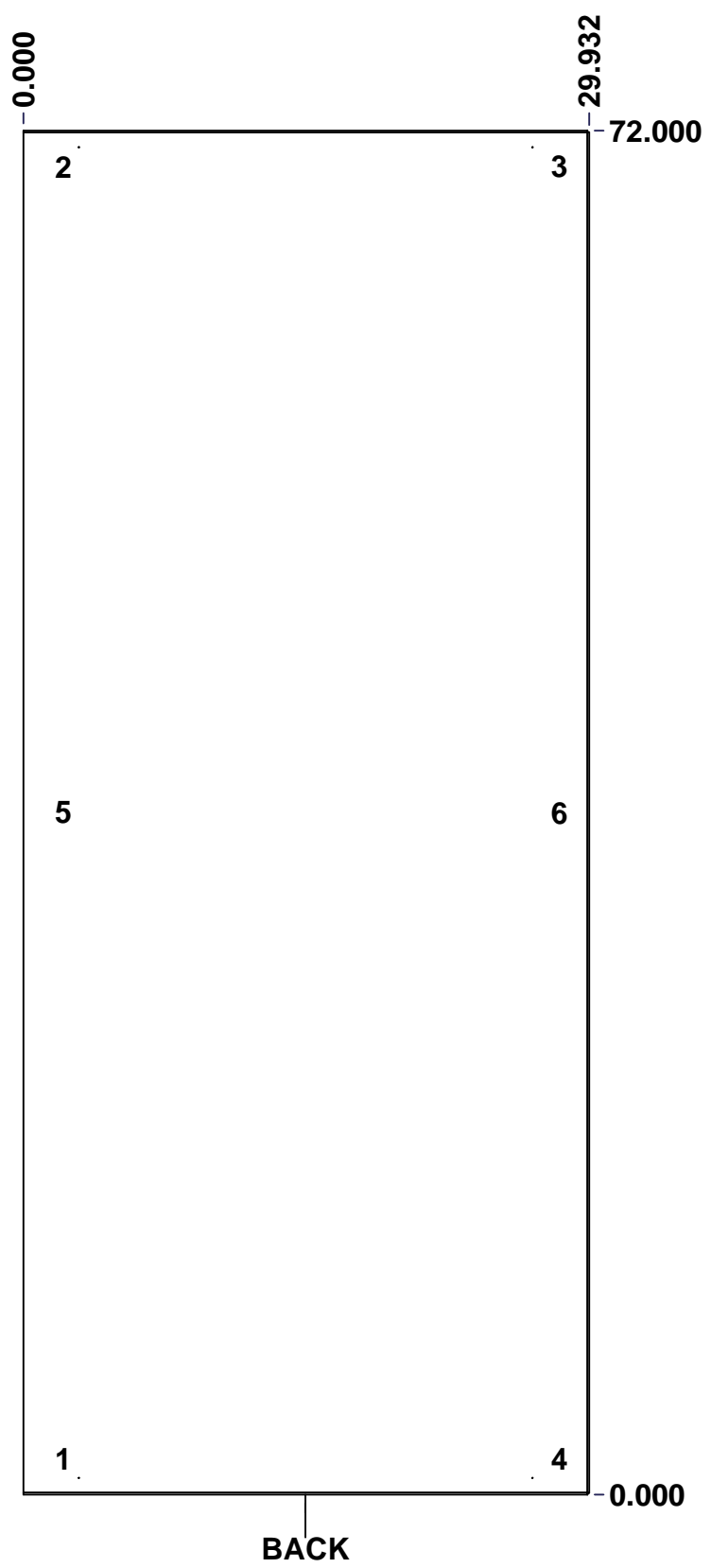

BACK

	Description	Status
	5412ESPR 72" x 30" x 16" Body	
	Part Number Numéro Pièce	Rev.
	<b>5412ESPR723016B</b>	<b>0</b>
		6 / 7

This drawing is confidential and must not be reproduced or used without the consent of EXM

Ce dessin est confidentiel et ne doit pas être reproduit ou utilisé sans le consentement de EXM

No.	Revisions	Date	By/Par

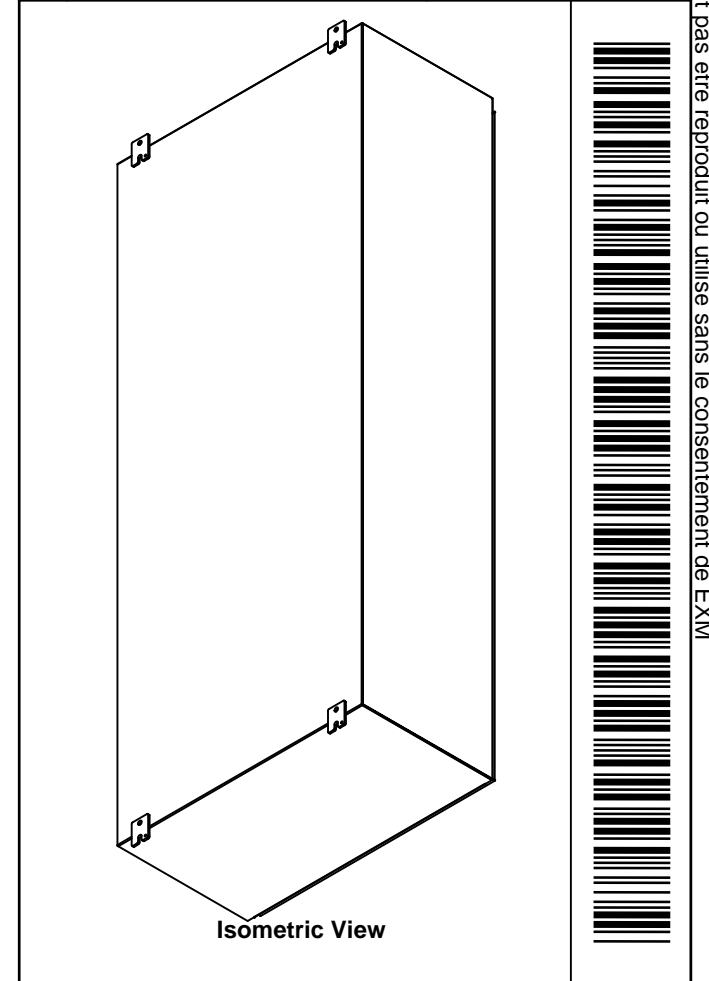

Tél: (450) 979-4373 Fax: (450) 979-4626 <a href="http://www.exmweb.com">www.exmweb.com</a>		Flatness Aplatissement Max 3.0mm Projection 
Customer Client	Date	
Drawn By Dessiné Par	BoxCad: Annie	Date 15/04/2014
Material Matière	14 Ga H.R.P. & O. (1.7mm)	
Color Couleur	Asa-61 Grey	Finish Fini Smooth
Description	Detail Rev.	
5412ESPR 72" x 30" x 16" Body		
Part Number Numéro Pièce	Rev. 0	7
<b>5412ESPR723016B</b>		7

Qty	Part Number	Rev	Description
1	STK-P-02400S	0	Powder Paint (Asa-61 Grey / Smooth)
4	STK-Q-71000	0	Steel Mounting Tab
6	STK-Q-16005	1	Stud M8 x 35 (No Paint Cap Required)
1	STK-Q-16080	0.1.1	M6 x 16mm Ground Stud
1	5412ESPR723016RS-P	0	5412ESPR 72" x 30" x 16" Body Part
1	5412ESPR723016B-P	0	5412ESPR 72" x 30" x 16" Body Part
Parts List			

This drawing is confidential and must not be reproduced or used without the consent of EXM

Ce dessin est confidentiel et ne doit pas être reproduit ou utilisé sans le consentement de EXM

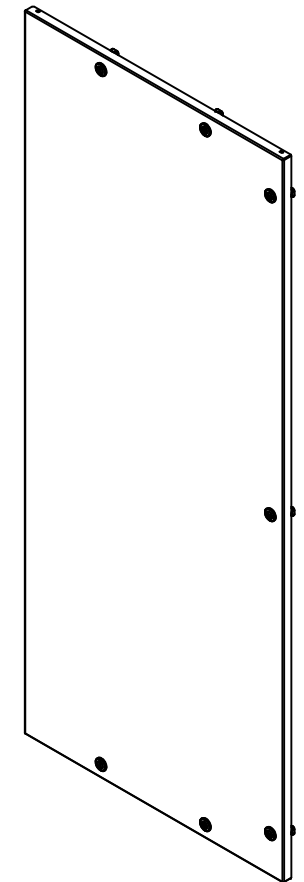
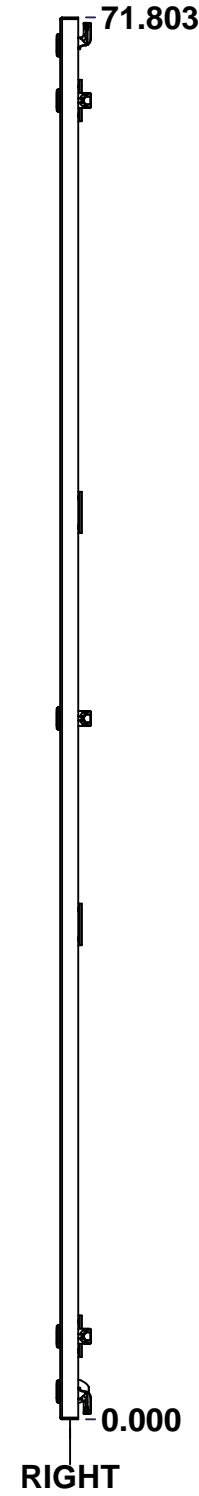
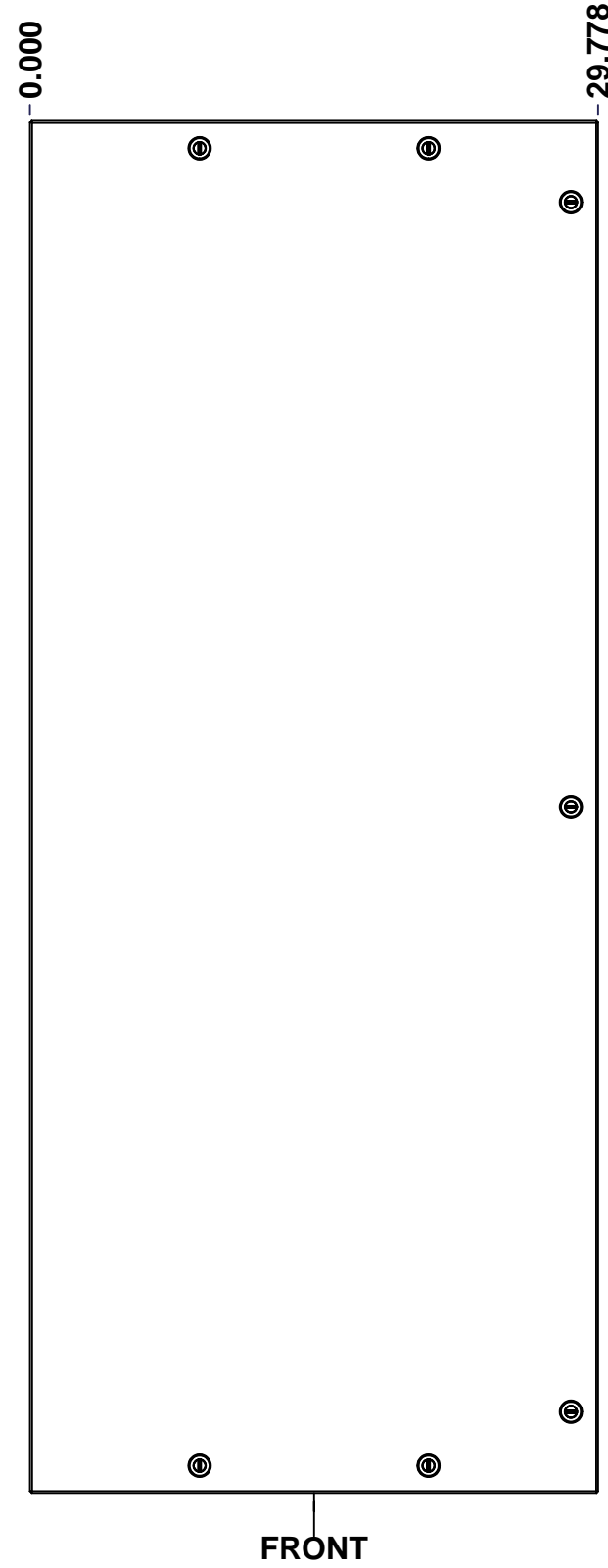
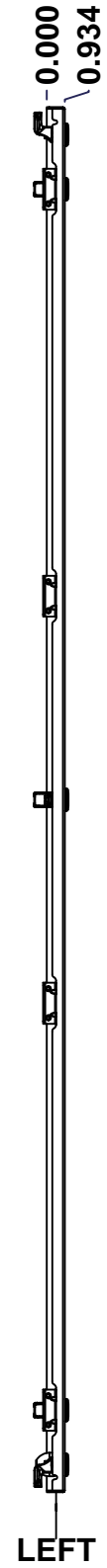
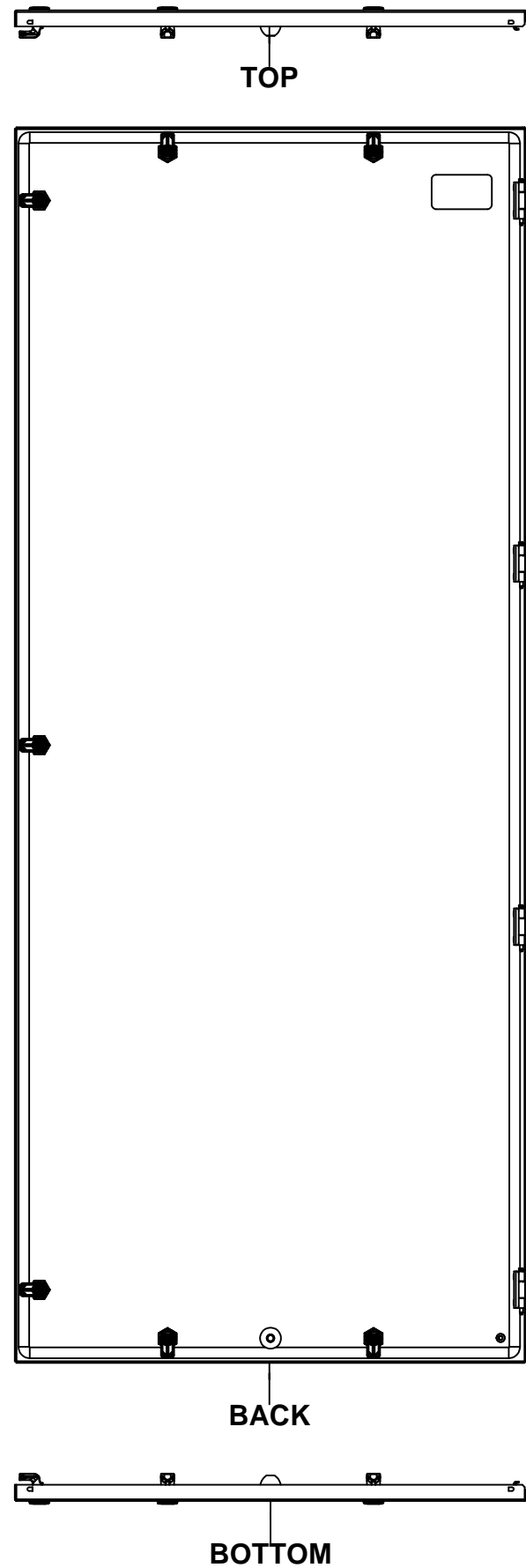

Isometric View

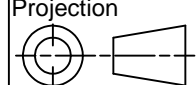

No.	Revisions	Date	By/Par

 Tél: (450) 979-4373 Fax: (450) 979-4626 <a href="http://www.exmweb.com">www.exmweb.com</a>		Flatness Aplatissement Max 3.0mm Projection 
Customer Client	Date	
Drawn By Dessiné Par	BoxCad: Annie	Date 15/04/2014
Material Matière	14 Ga H.R.P. & O. (1.7mm)	
Color Couleur	Asa-61 Grey	Finish Fini Smooth
Description	Detail Rev.	
5412ESPR 72" x 30" Cover		
Part Number Numéro Pièce	Rev. 0	1 / 3
<b>5412ESPR723016C</b>		

SEE BILL OF MATERIAL ON LAST PAGE

This drawing is confidential and must not be reproduced or used without the consent of EXM

Ce dessin est confidentiel et ne doit pas être reproduit ou utilisé sans le consentement de EXM

STANDARD FEATURES ARE NOT LISTED IN THIS HOLE TABLE			
HOLE TABLE - FRONT VIEW (CUSTOM FEATURE ONLY)			
CUT-OUT	XDIM	YDIM	DESCRIPTION
1	1.486	1.453	GND STUD M6 x 16mm (Inside)
2	14.959	1.435	STUD M6 x 18mm (Inside)

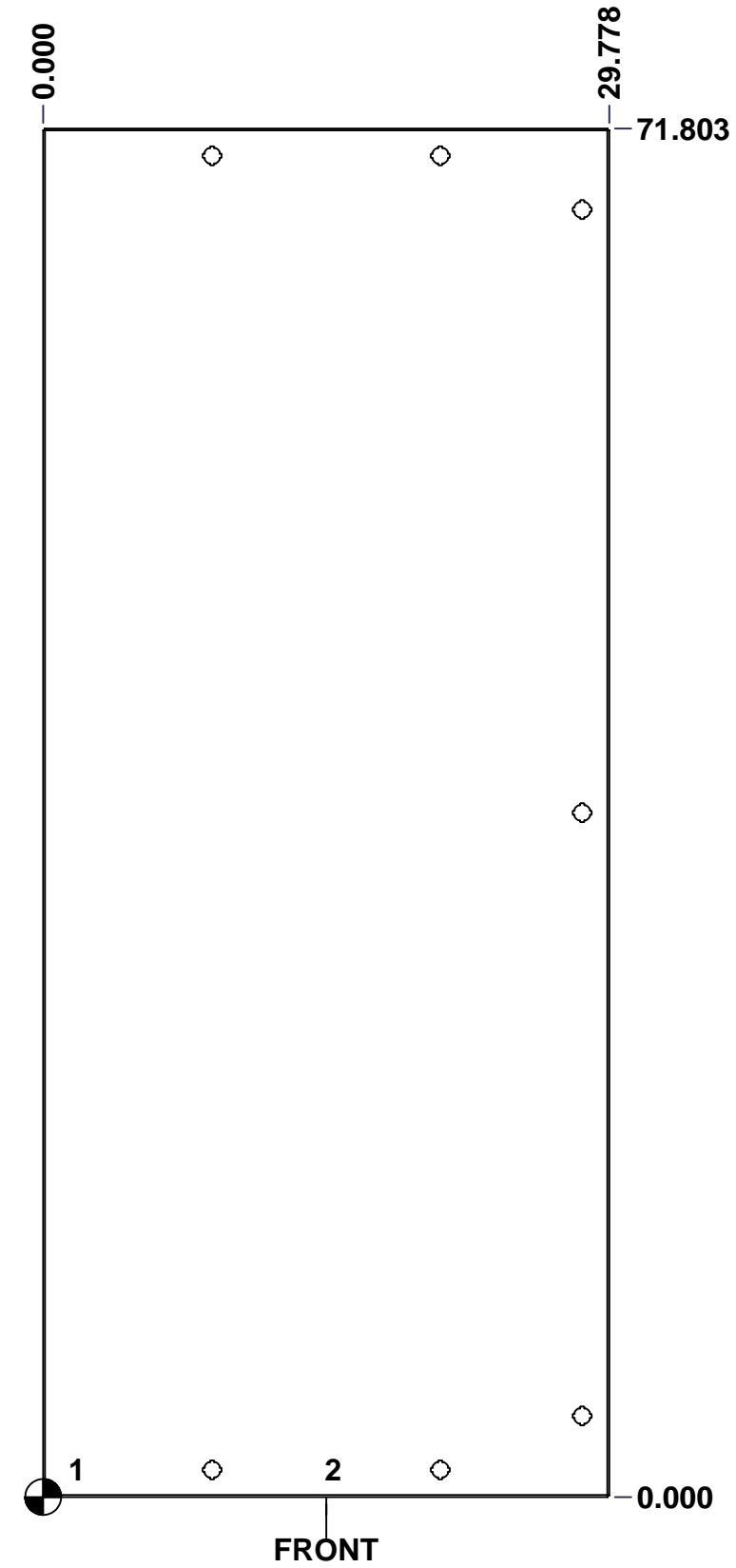

	Description	Status	
	5412ESPR 72" x 30" Cover	(NULL)	
	Part Number Numéro Pièce	Rev.	
	<b>5412ESPR723016C</b>	<b>0</b>	2 3



This drawing is confidential and must not be reproduced or used without the consent of EXM

Ce dessin est confidentiel et ne doit pas être reproduit ou utilisé sans le consentement de EXM

No.	Revisions	Date	By/Par

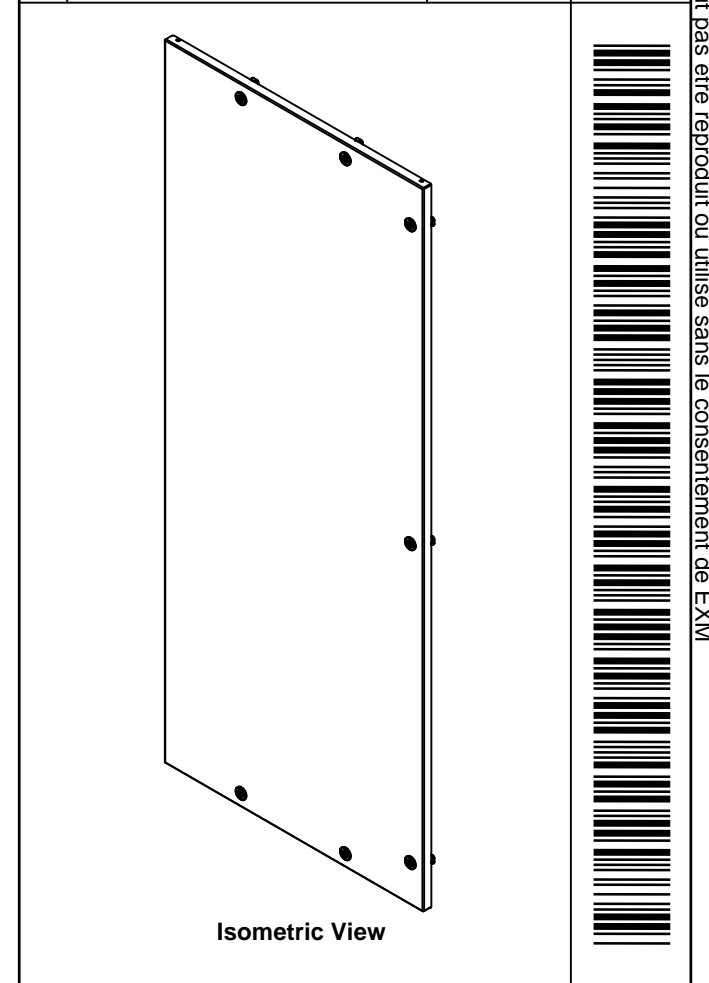

Qty	Part Name	Rev	Description
1	STK-P-02400S	0	Powder Paint (Asa-61 Grey / Smooth)
1	STK-S-00100	0.1.1	3.5" x 2" Silver Milar Flexcon Sticker
1	STK-Q-46515	2	5412 ES Door Support with Brass Insert
1	STK-Q-16055	1	M6 x 18mm Stud (No Paint Cap Required)
1	STK-Q-16080	0.1.1	M6 x 16mm Ground Stud
4	STK-Q-33105	4	5412 ESBU Buttable Hinge (Cover Part)
1	5412ESPR723016G	0	5412ESPR 72" x 30" Cover Gasket
1	5412ESPR723016C-P	0	5412ESPR 72" x 30" Cover Part
7	880 SCQ4-SL	0	5412 ES 1/4 Turn Lock
4	STK-A-33005	1	5412 ESBU Hinge 180° (Body Part)
Parts List			



Tél: (450) 979-4373  
Fax: (450) 979-4626  
[www.exmweb.com](http://www.exmweb.com)

Flatness  
Aplatissement  
Max 3.0mm

Projection

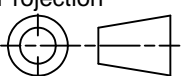

Customer Client	Date
Drawn By Dessiné Par BoxCad: Annie	Date 15/04/2014
Material Matière 14 Ga H.R.P. & O. (1.7mm)	
Color Couleur Asa-61 Grey	Finish Fini Smooth
Description 5412ESPR 72" x 30" Cover	Detail Rev.
Part Number Numéro Pièce <b>5412ESPR723016C</b>	Rev. 3
	<b>0</b>

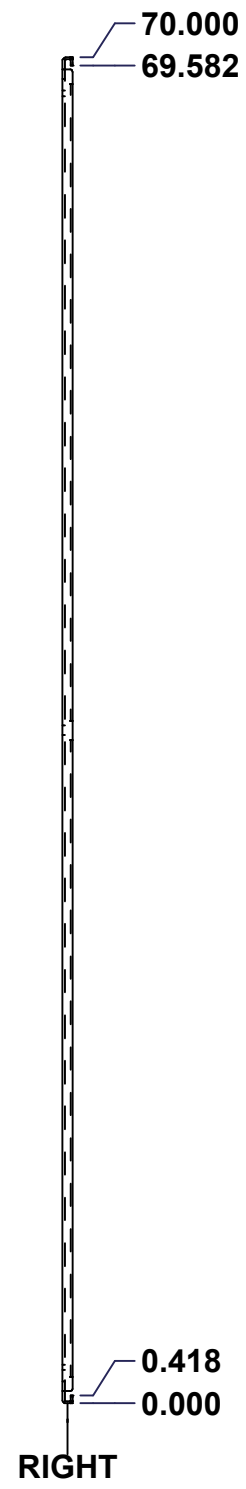
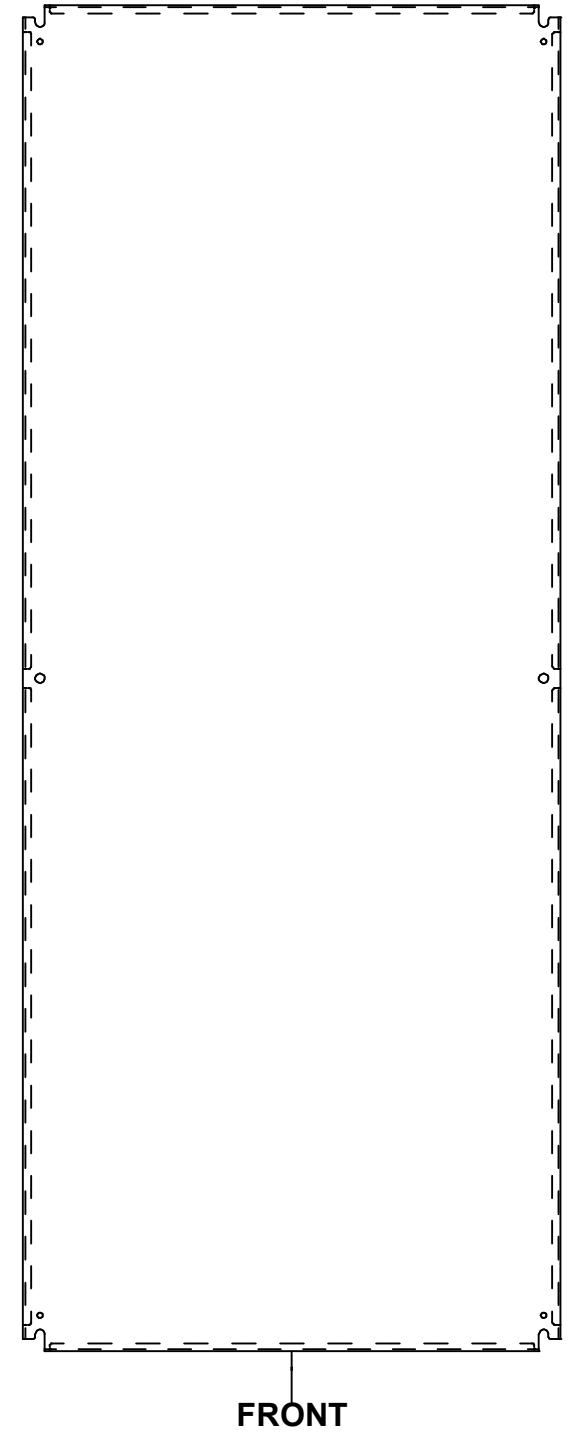
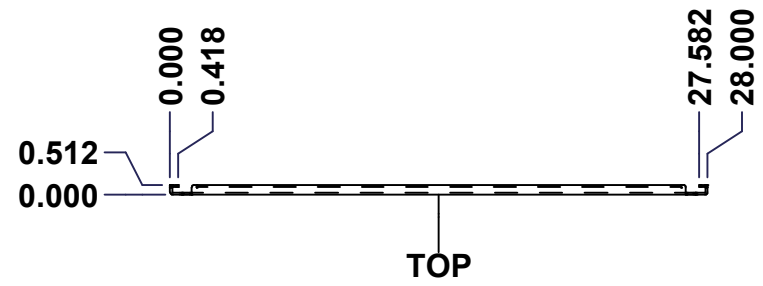

No.	Revisions	Date	By/Par

Isometric View

Flatness  
Aplatissement  
Max 3.0mm

Projection

Customer Client  
Date

Drawn By / Dessiné Par: BoxCad  
Date: 1/23/2007

Material / Matière: See Part List

Color / Couleur: See Part List  
Finish / Fini: See Part List

Description: 881 SP - Inner Panel  
Detail Rev.

Part Number / Numéro Pièce: **881 SP7230**  
Rev. 0

Qty	Part Number	Rev	Description	Material	Color	Finish
1	STK-P-02401S	0	Powder Paint (White / Smooth)	Polyester-Epoxy Hybrid	White RAL9003	Smooth
1	881 SP7230-P	0	881 SP - Inner Panel Part	12 Ga H.R.P. & O.	White	Smooth

Parts List

This drawing is confidential and must not be reproduced or used without the consent of EXM

Ce dessin est confidentiel et ne doit pas être reproduit ou utilisé sans le consentement de EXM

This drawing is confidential and must not be reproduced or used without the consent of EXM

Ce dessin est confidentiel et ne doit pas être reproduit ou utilisé sans le consentement de EXM

Table 1			FRONT VIEW
CUT-OUT	XDIM	YDIM	DESCRIPTION
1	0.875	1.875	GROUND HOLE (RND Ø0.290)
2	27.125	1.875	GROUND HOLE (RND Ø0.290)
3	0.875	68.125	GROUND HOLE (RND Ø0.290)
4	27.125	68.125	GROUND HOLE (RND Ø0.290)
5	0.875	35.000	MTG STUD HOLE (RND Ø0.500)
6	27.125	35.000	MTG STUD HOLE (RND Ø0.500)

All knockouts are actual size / Les disques défonçables sont grandeur réel

No.	Revisions	Date	By/Par

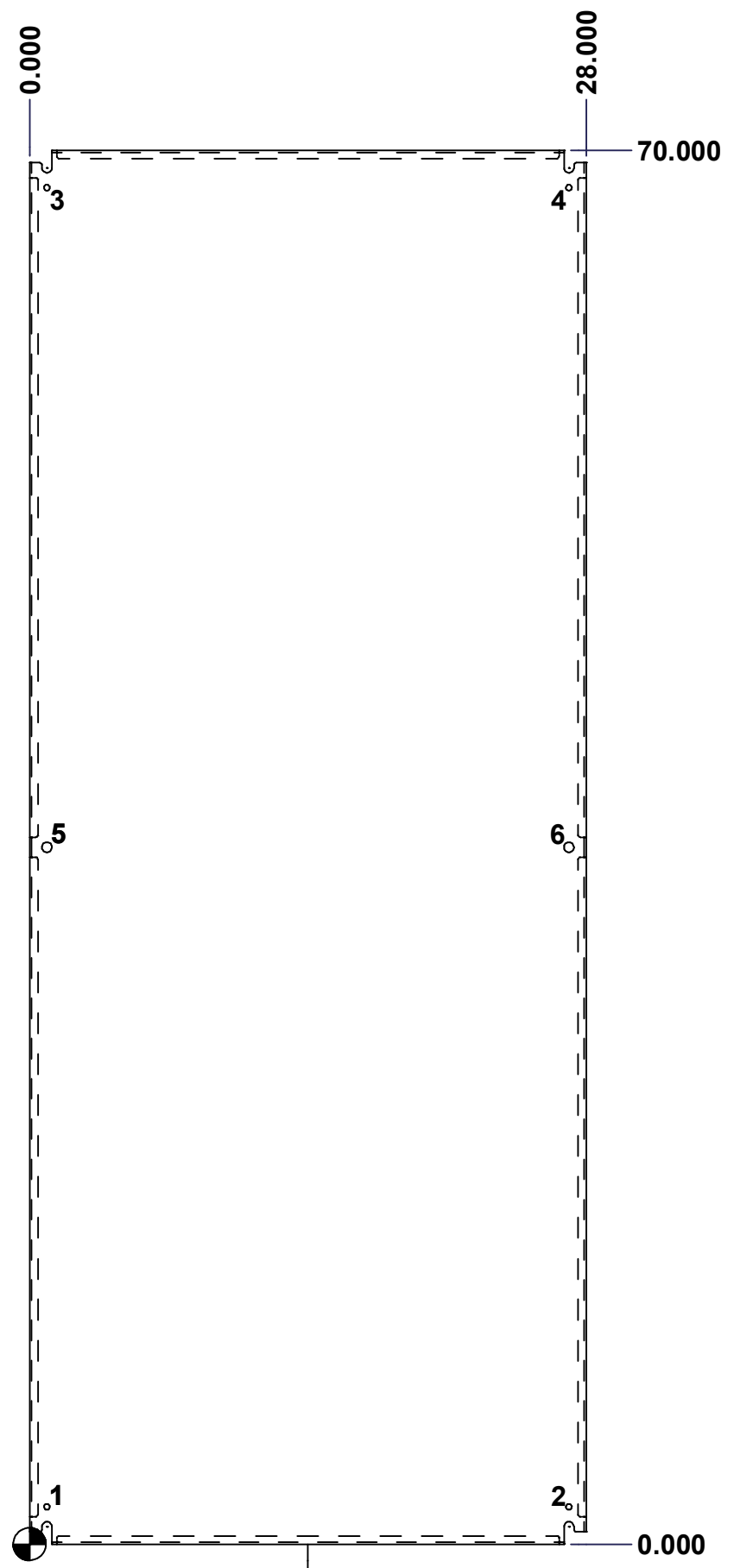

FRONT

Isometric View

		Tél: (450) 979-4373 Fax: (450) 979-4626 www.exmweb.com		Flatness Aplatissement Max 3.0mm
Customer Client		Date		Projection 
Drawn By Dessiné Par		BoxCad		Date 1/23/2007
Material Matière		See Part List		
Color Couleur		See Part List		Finish Fini
Description 881 SP - Inner Panel				Detail Rev.
Part Number Numéro Pièce <b>881 SP7230</b>				Rev. 2 <b>0</b>