

This drawing is confidential and must not be reproduced or used without the consent of EXM

Ce dessin est confidentiel et ne doit pas être reproduit ou utilisé sans le consentement de EXM

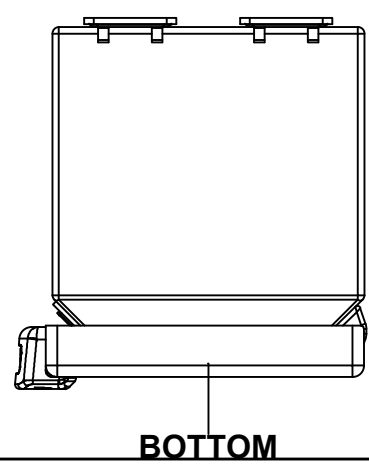

No.	Revisions	Date	By/Par

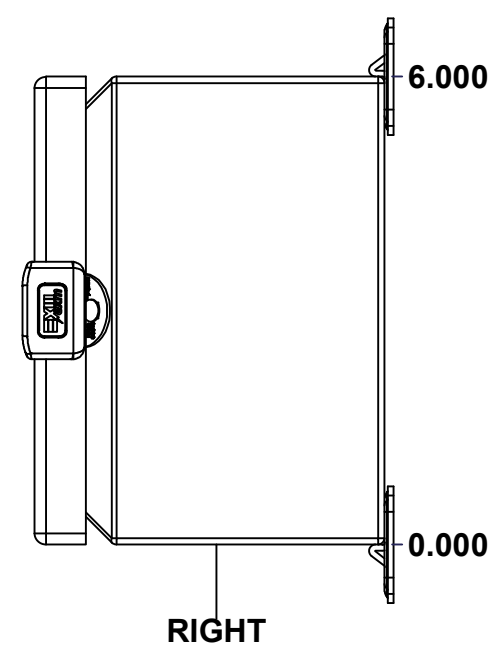
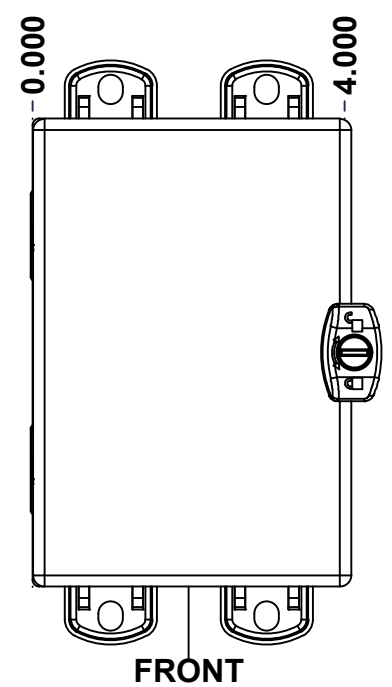
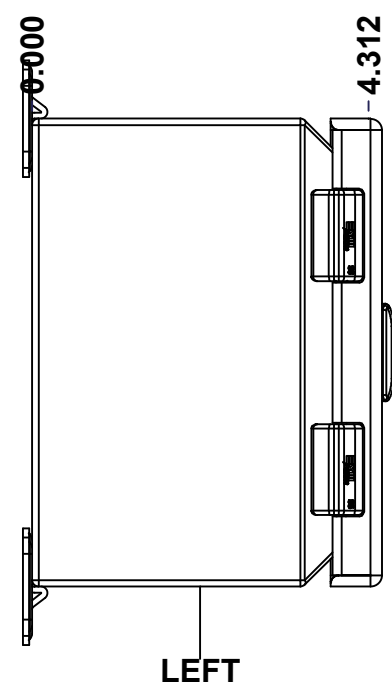
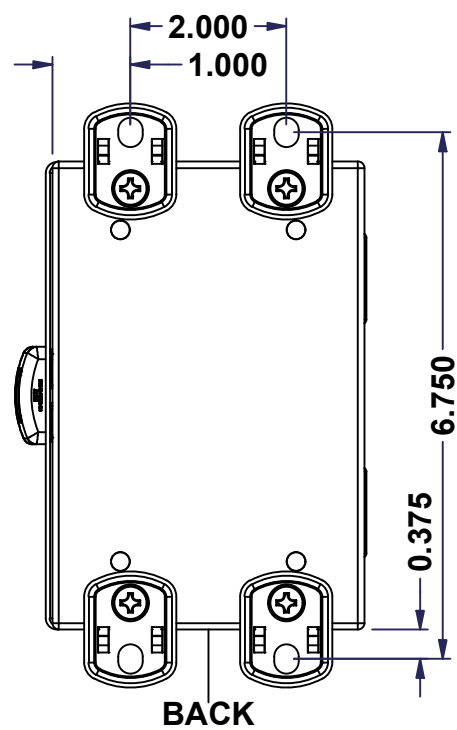
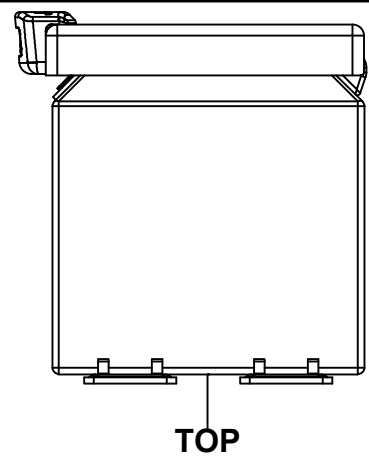
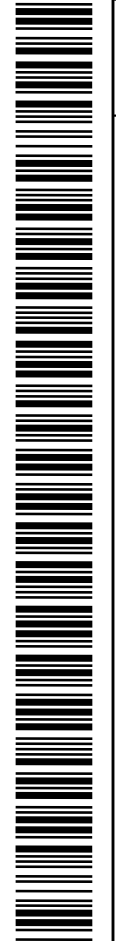
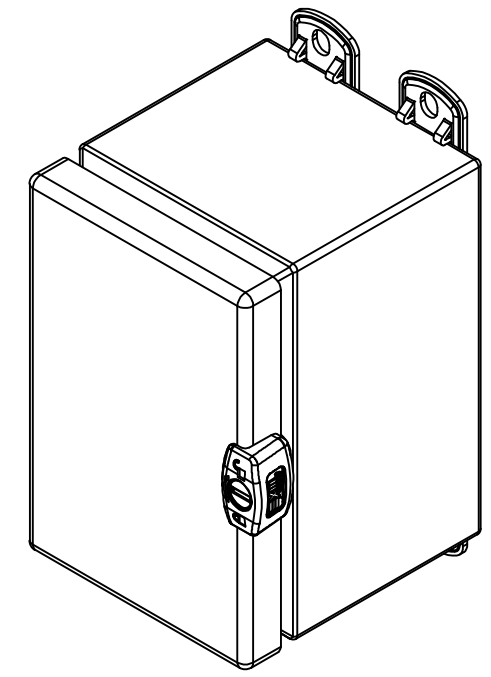

**GRAIN DIRECTION:
TOP/BOTTOM: HORIZONTAL
LEFT/RIGHT/BACK/FRONT: VERTICAL**

SEE BILL OF MATERIAL ON LAST PAGE

 Tél: (450) 979-4373 Fax: (450) 979-4626 www.exmweb.com		Flatness Aplatissement
		Max 3.0mm
Customer Client		Date
Drawn By Dessiné Par BoxCad: BoxCad		Date 18-Nov-14
Material Matière 16 Ga Stainless Steel 304 (1.4mm)		
Color Couleur Unpainted	Finish Fini Brushed	
Description 5412ESSMCH 6" x 4" x 4" Assembly		Detail Rev.
Part Number Numéro Pièce 5412ESSMCH060404		Rev. 1 0

This drawing is confidential and must not be reproduced or used without the consent of EXM

Ce dessin est confidentiel et ne doit pas être reproduit ou utilisé sans le consentement de EXM

NOTE	
ITEM	DESCRIPTION
1	NEMA 4X Enclosure
2	C/W Standard ground standoffs on box and cover
3	W/O Standard door stiffener
4	C/W Standard inner panel (Included)
5	C/W Standard inner panel mounting standoffs
6	C/W 885 ESCHMF2 Mounting Feet (Kit)

No.	Revisions	Date	By/Par

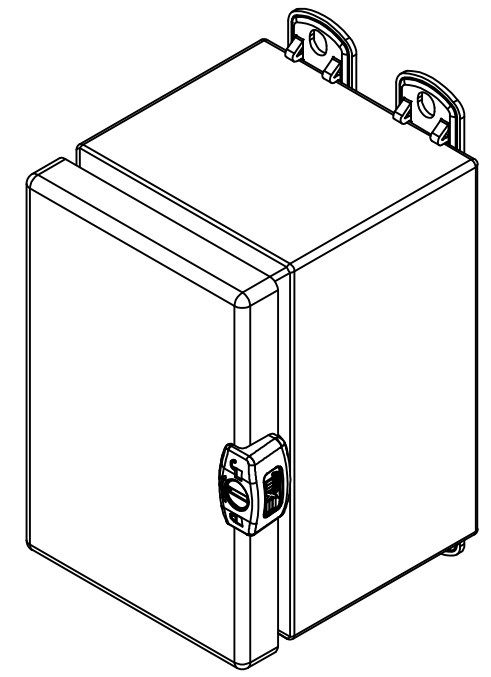

Isometric View



Tél: (450) 979-4373
 Fax: (450) 979-4626
www.exmweb.com



Customer Client	Date
Drawn By / Dessiné Par: BoxCad: BoxCad	Date: 18-Nov-14

Material / Matière: 16 Ga Stainless Steel 304 (1.4mm)

Color / Couleur: Unpainted	Finish / Fini: Brushed
----------------------------	------------------------

Description: 5412ESSMCH 6" x 4" x 4" Assembly

Part Number / Numéro Pièce: 5412ESSMCH060404	Rev. 0	2 / 10
-----------------------------------------------------	--------	--------

Qty	Part Number	Rev	Description
1	5412ESSMCH060404C	0	5412ESSMCH 6" x 4" Cover
1	STK-K-02945	0	5412 ESSMCH Accessory Kit
8	STK-Q-07200	0	Flange Lock Nut
1	880 SP0604G	0	880 SP0604G - Inner Panel
1	5412ESSMCH060404B	0	5412ESSMCH 6" x 4" x 4" Body
2	STK-Q-08100	1	M5 Nylon Insert Lock Nut
2	STK-Q-10249	0	M5 Sealing Washer

Parts List

PACKING		
ITEM	QTY	DESCRIPTION
STK-E-04302	1	CARTON 5412 ESCH060404
Plastic bag	1	To protect cover surface and inside gasket
Packaging label	1	White label with product number
STK-S-01100	1	ESCH EXM SQUARE STICKER

This drawing is confidential and must not be reproduced or used without the consent of EXM

Ce dessin est confidentiel et ne doit pas être reproduit ou utilisé sans le consentement de EXM

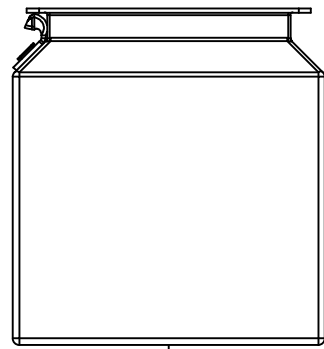

TOP

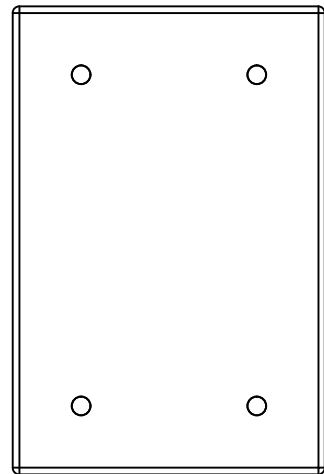

BACK

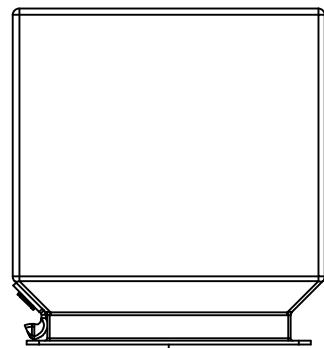

BOTTOM

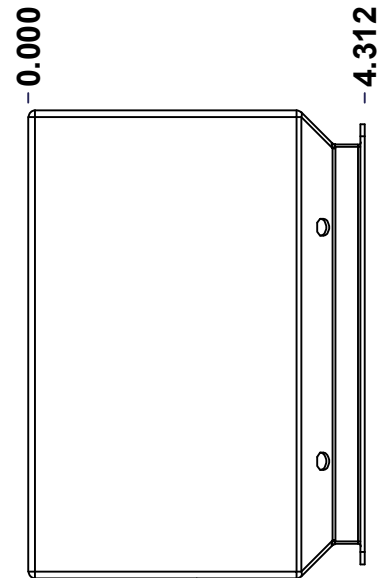

LEFT

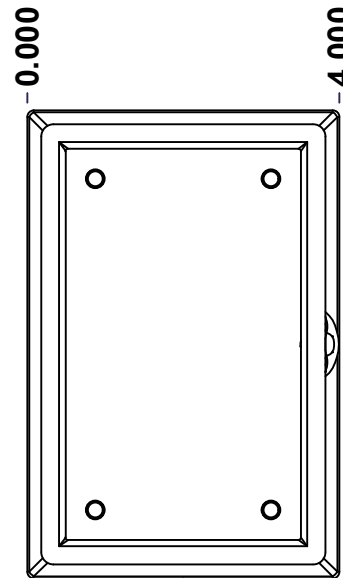

FRONT

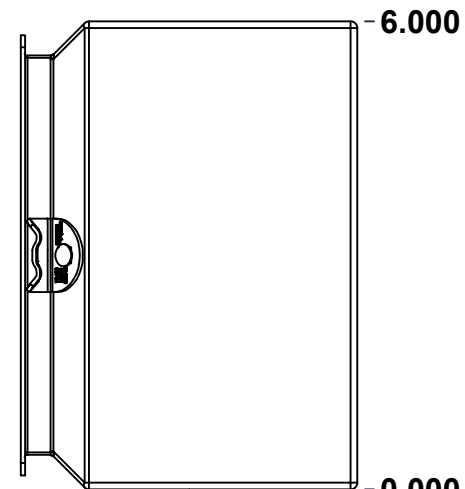

RIGHT

No.	Revisions	Date	By/Par

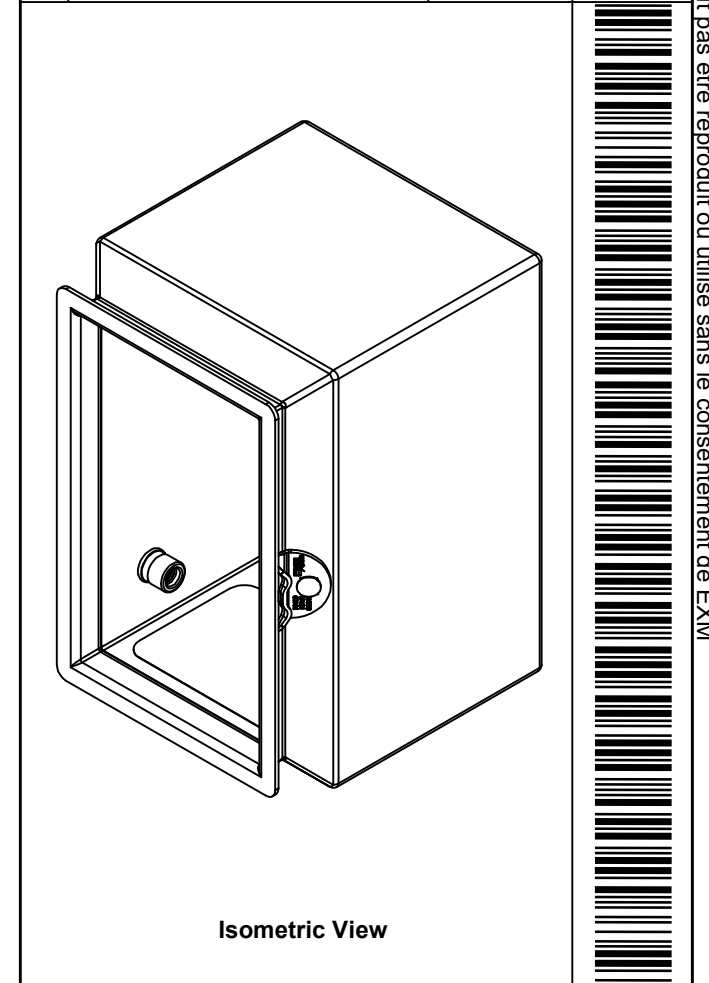

Isometric View

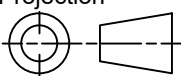

 Tél: (450) 979-4373 Fax: (450) 979-4626 www.exmweb.com		Flatness Aplatissement Max 3.0mm Projection 
Customer Client	Date	
Drawn By Dessiné Par	BoxCad: BoxCad	Date 18-Nov-14
Material Matière	16 Ga Stainless Steel 304 (1.4mm)	
Color Couleur	Unpainted	Finish Fini Brushed
Description	Detail Rev.	
5412ESSMCH 6" x 4" x 4" Body		
Part Number Numéro Pièce	Rev.	3
5412ESSMCH060404B	0	10

SEE BILL OF MATERIAL ON LAST PAGE

This drawing is confidential and must not be reproduced or used without the consent of EXM

Ce dessin est confidentiel et ne doit pas être reproduit ou utilisé sans le consentement de EXM

STANDARD FEATURES ARE NOT LISTED IN THIS HOLE TABLE			
HOLE TABLE - BOTTOM VIEW (CUSTOM FEATURE ONLY)			
CUT-OUT	XDIM	YDIM	DESCRIPTION
1	2.000	2.250	LABEL_EXM

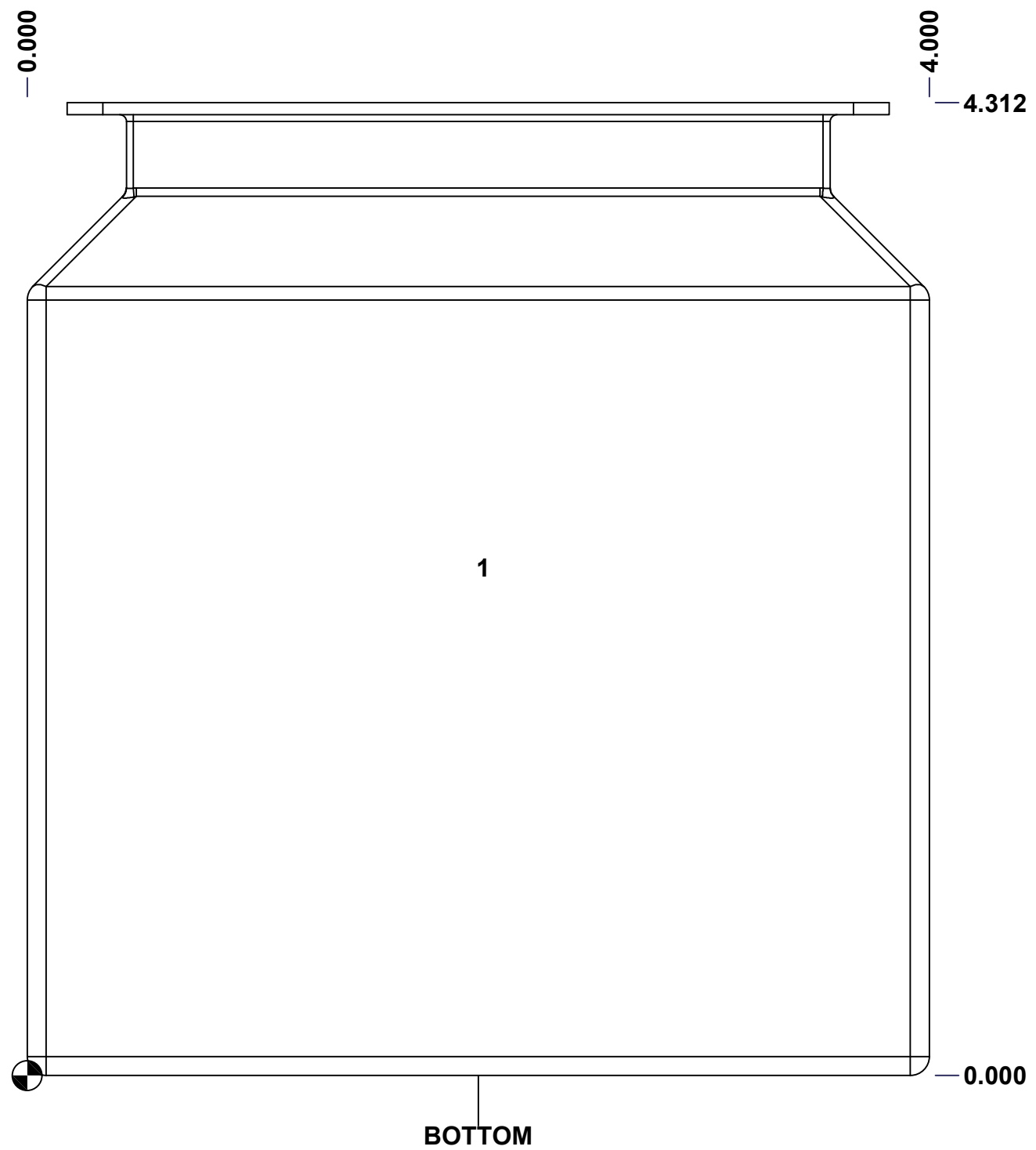

	Description	Status	
	5412ESSMCH 6" x 4" x 4" Body	(NULL)	
	Part Number Numéro Pièce	Rev.	
	5412ESSMCH060404B	0	4 10

This drawing is confidential and must not be reproduced or used without the consent of EXM

Ce dessin est confidentiel et ne doit pas être reproduit ou utilisé sans le consentement de EXM

STANDARD FEATURES ARE NOT LISTED IN THIS HOLE TABLE			
HOLE TABLE - LEFT VIEW (CUSTOM FEATURE ONLY)			
CUT-OUT	XDIM	YDIM	DESCRIPTION
1	2.625	0.875	STANDOFF M6 x 10mm (Inside)

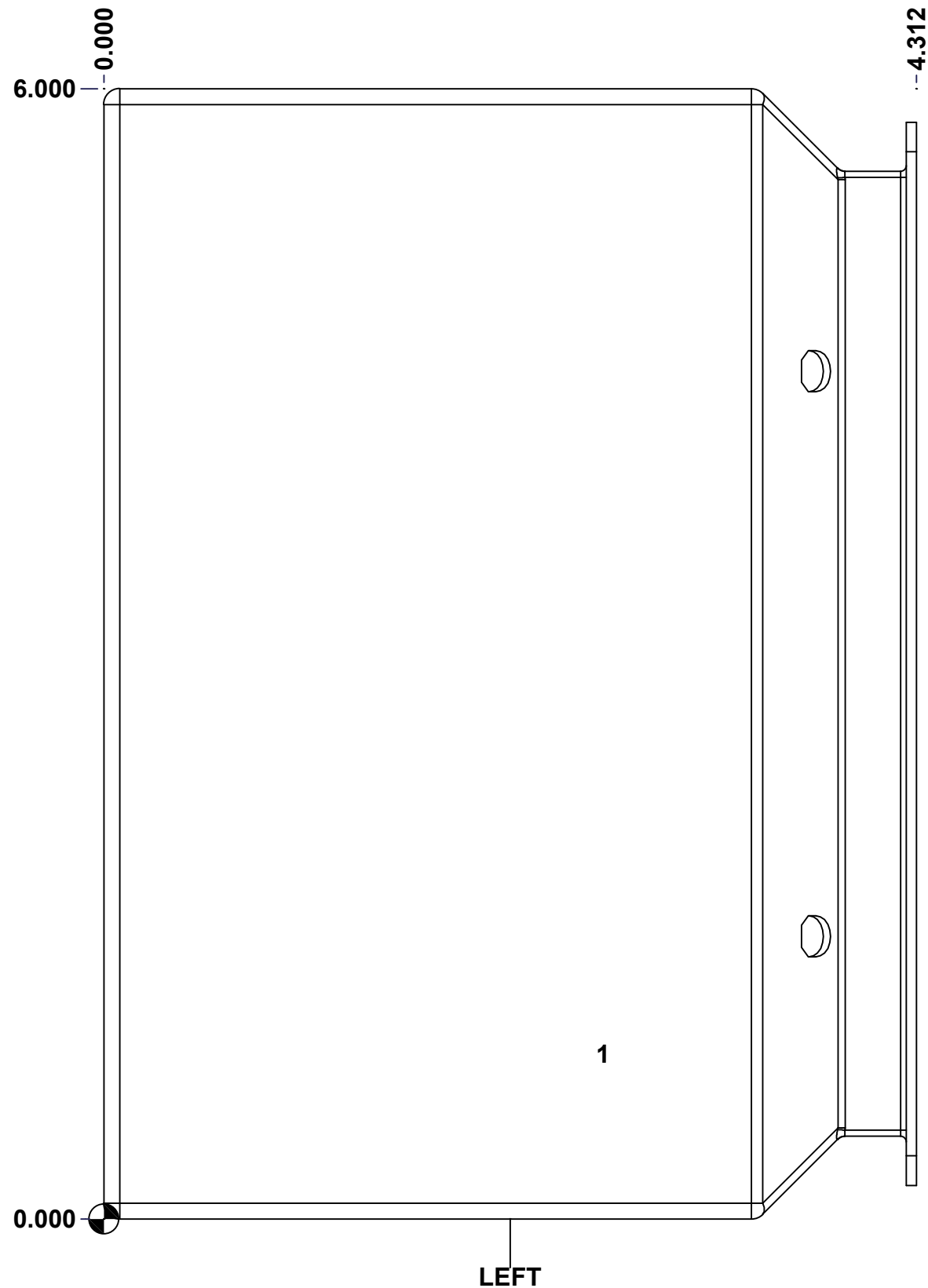

	Description	Status	
	5412ESSMCH 6" x 4" x 4" Body	(NULL)	
	Part Number Numéro Pièce	Rev.	
	5412ESSMCH060404B	0	5 10

This drawing is confidential and must not be reproduced or used without the consent of EXM

Ce dessin est confidentiel et ne doit pas être reproduit ou utilisé sans le consentement de EXM

STANDARD FEATURES ARE NOT LISTED IN THIS HOLE TABLE

HOLE TABLE - BACK VIEW (CUSTOM FEATURE ONLY)

CUT-OUT	XDIM	YDIM	DESCRIPTION
1	1.000	0.000	FOOT 885 ESCHMF2
2	3.000	6.000	FOOT 885 ESCHMF2
3	1.000	6.000	FOOT 885 ESCHMF2
4	3.000	0.000	FOOT 885 ESCHMF2
5	0.875	5.125	PEM FHS-M6-20 (Inside)
6	3.125	5.125	PEM FHS-M6-20 (Inside)
7	3.125	0.875	PEM FHS-M6-20 (Inside)
8	0.875	0.875	PEM FHS-M6-20 (Inside)

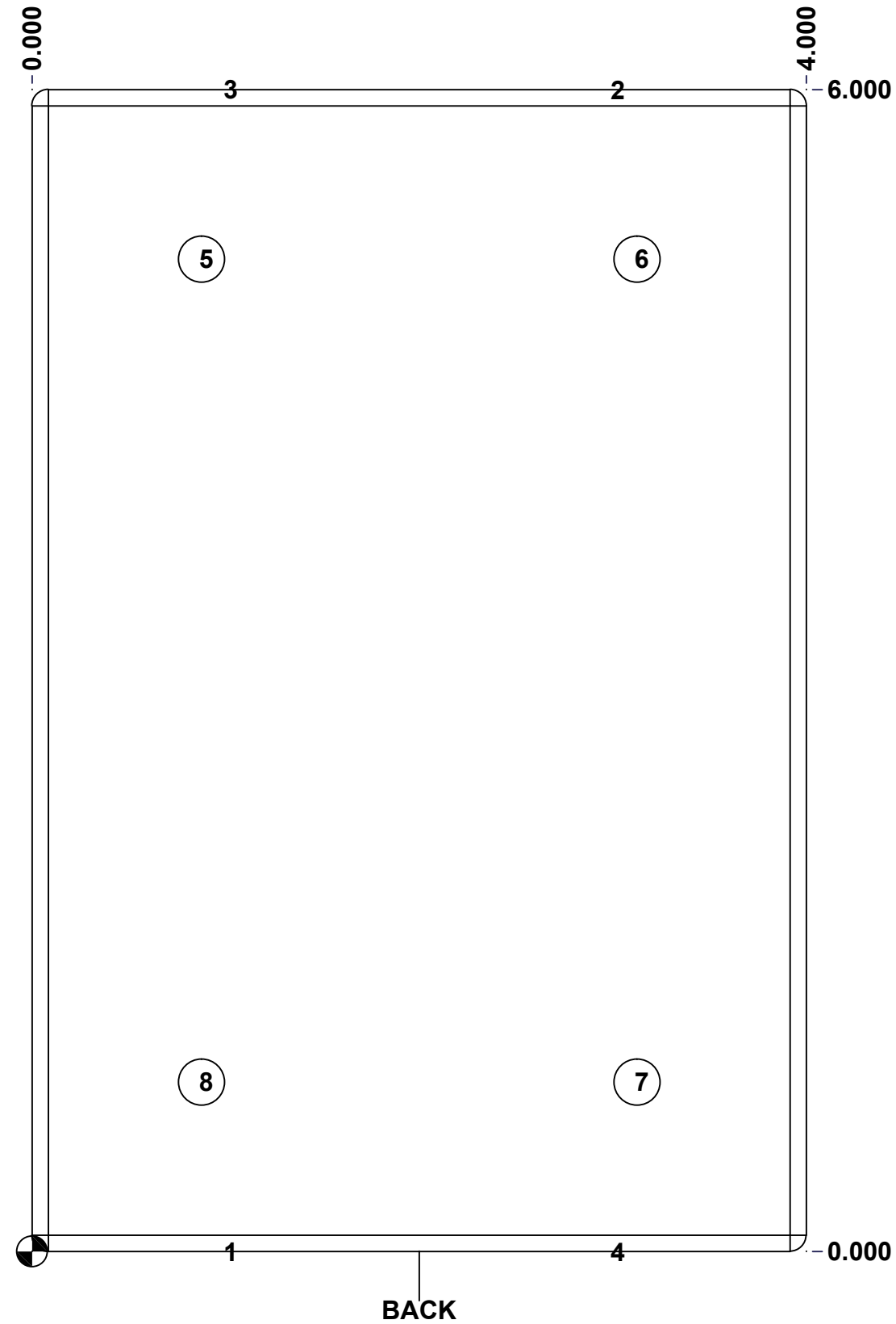



	Description	Status
	5412ESSMCH 6" x 4" x 4" Body	(NULL)
Part Number Numéro Pièce 5412ESSMCH060404B	Rev.	6
	0	10

This drawing is confidential and must not be reproduced or used without the consent of EXM

Ce dessin est confidentiel et ne doit pas être reproduit ou utilisé sans le consentement de EXM

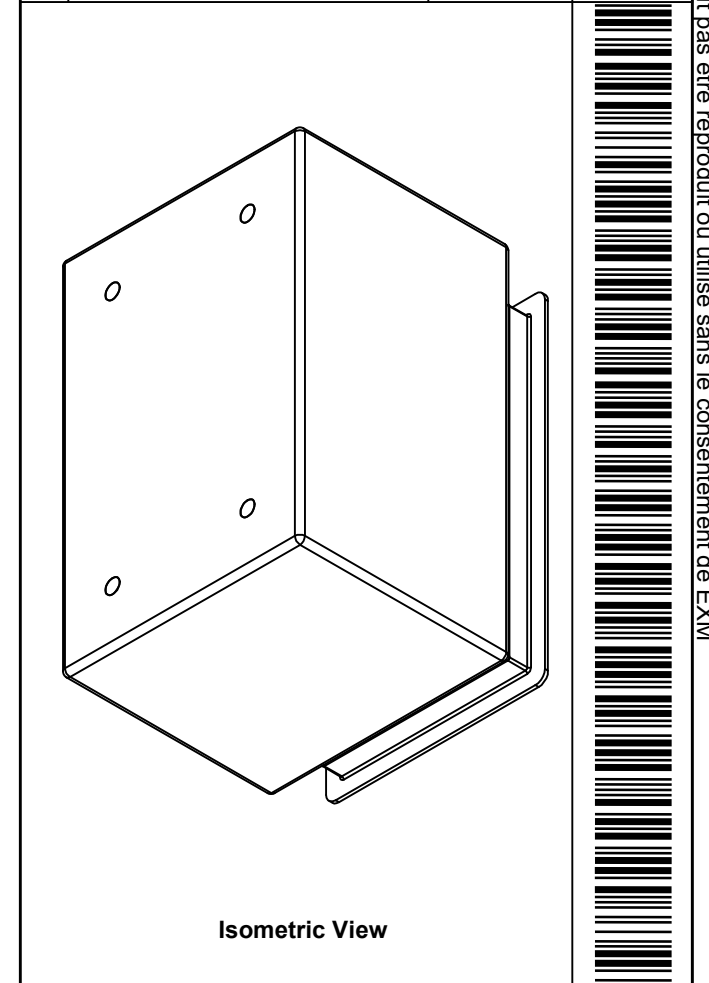
No.	Revisions	Date	By/Par

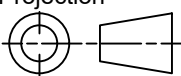

 Tél: (450) 979-4373 Fax: (450) 979-4626 www.exmweb.com		Flatness Aplatissement Max 3.0mm Projection 
Customer Client	Date	
Drawn By Dessiné Par	BoxCad: BoxCad	Date 18-Nov-14
Material Matière	16 Ga Stainless Steel 304 (1.4mm)	
Color Couleur	Unpainted	Finish Fini Brushed
Description		Detail Rev.
5412ESSMCH 6" x 4" x 4" Body		
Part Number Numéro Pièce	Rev.	7
5412ESSMCH060404B	0	10

Qty	Part Number	Rev	Description
4	STK-PEM-FHS-M6-20	0	SS PEM Self-Clinching Stud M6 x 20.0mm
1	STK-Q-08500	4	Stainless Steel Standoff M6 x 10mm
1	STK-Q-08100	1	M5 Nylon Insert Lock Nut
1	5412ESSMCH060404B-P	0	5412ESSMCH 6" x 4" x 4" Body Part
1	STK-S-00100	0	3.5" x 2" Silver Milar Flexcon Sticker
1	STK-A-70469	6	5412 ESSMCH - Stainless Steel 316 Body Catch Assembly
Parts List			

This drawing is confidential and must not be reproduced or used without the consent of EXM

Ce dessin est confidentiel et ne doit pas être reproduit ou utilisé sans le consentement de EXM

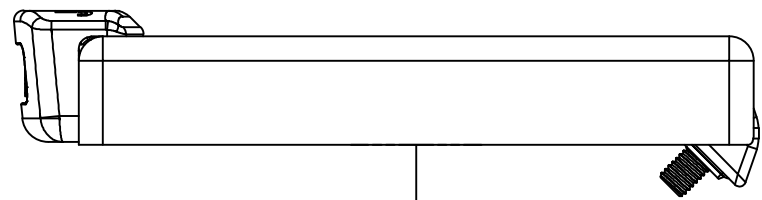

TOP

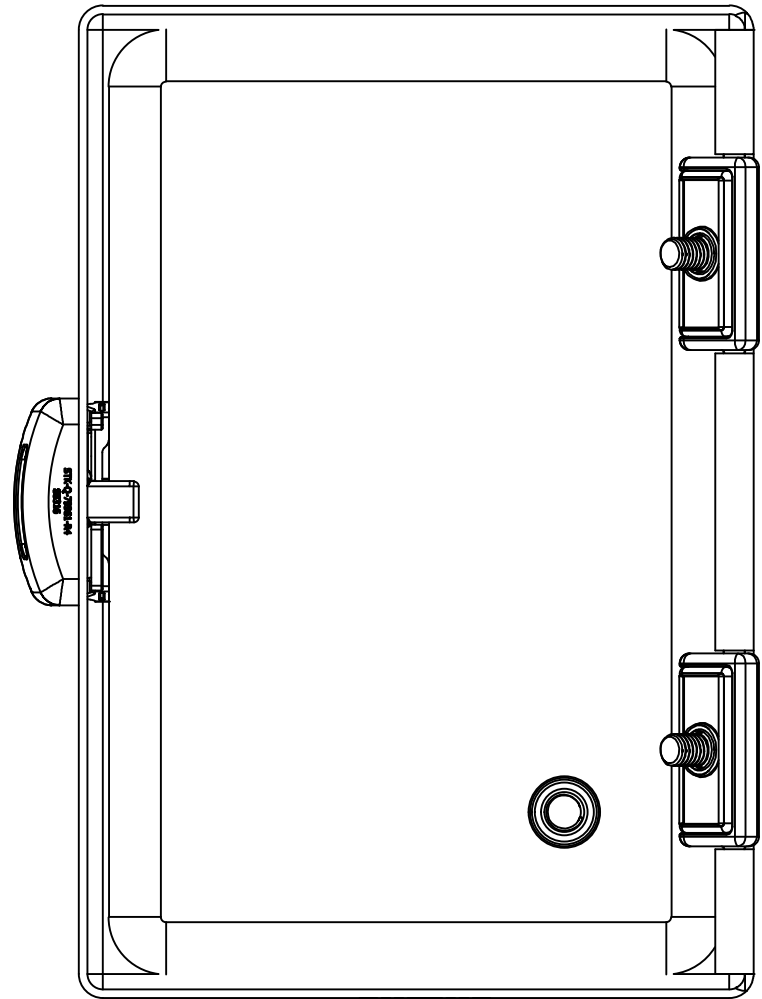

BACK

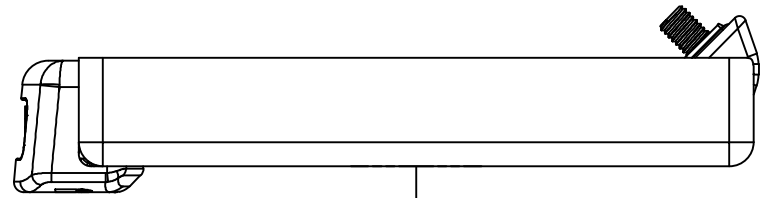

BOTTOM

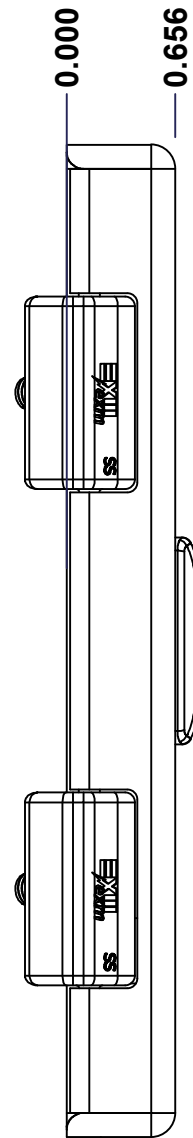

LEFT

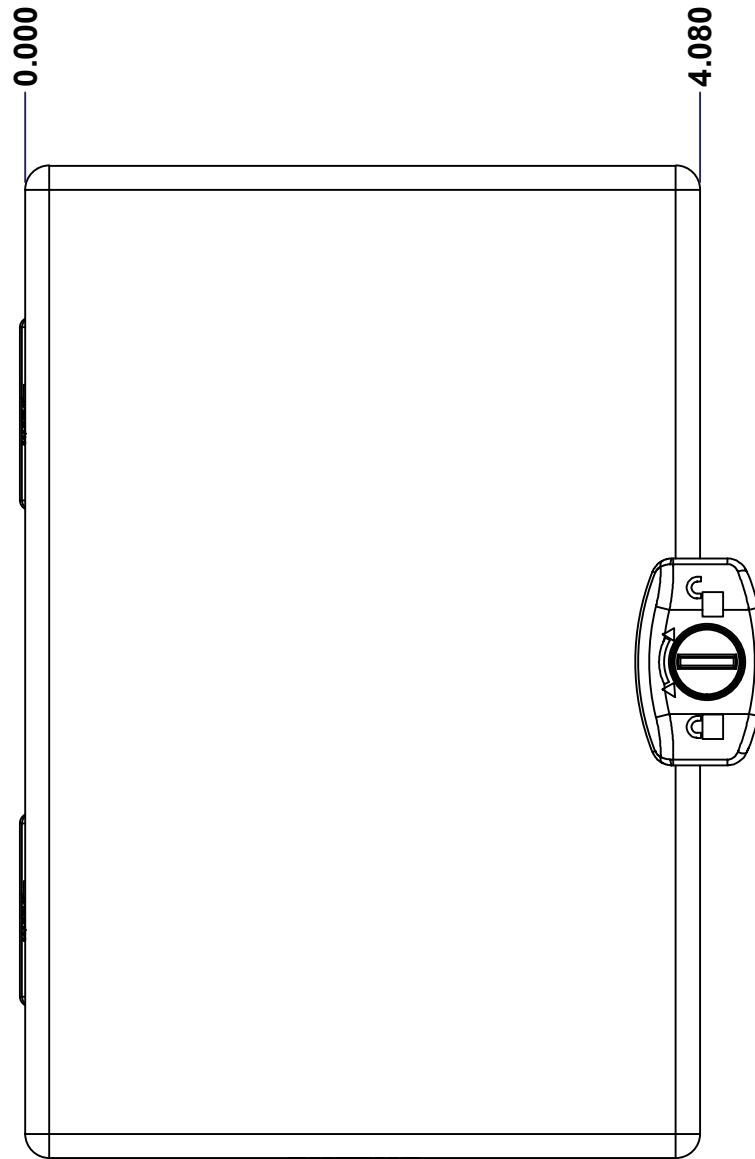

FRONT

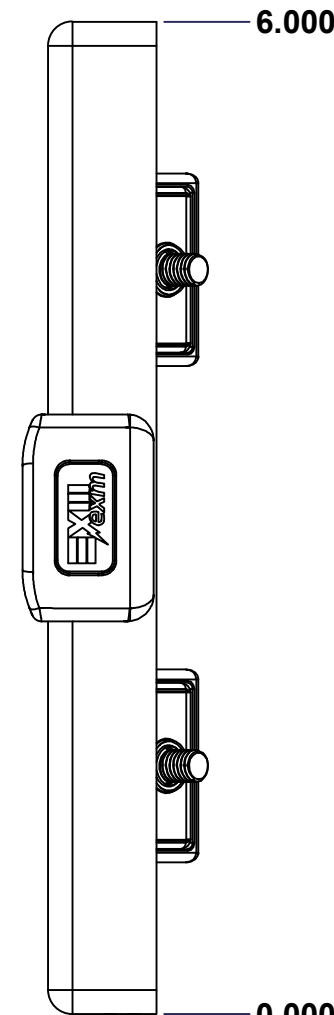

RIGHT

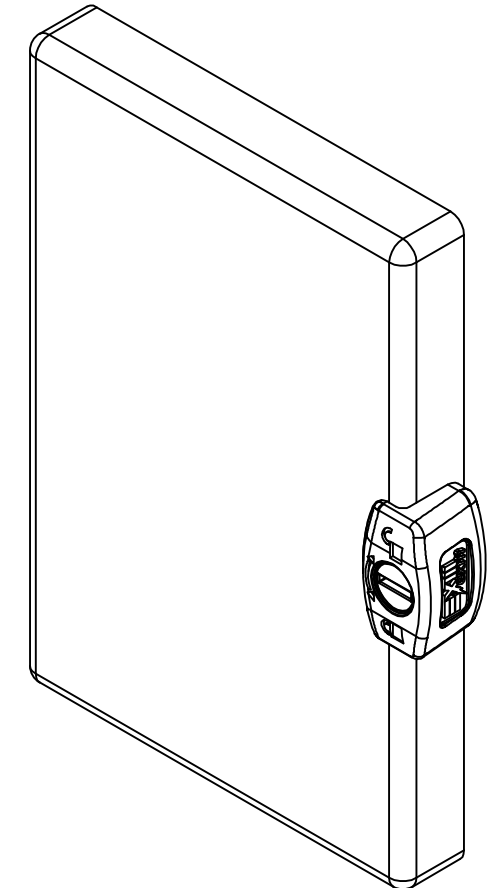

Isometric View

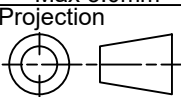

No.	Revisions	Date	By/Par

 Tél: (450) 979-4373 Fax: (450) 979-4626 www.exmweb.com		Flatness Aplatissement Max 3.0mm Projection 
Customer Client	Date	
Drawn By Dessiné Par	BoxCad: BoxCad	Date 18-Nov-14
Material Matière	16 Ga Stainless Steel 304 (1.4mm)	
Color Couleur	Unpainted	Finish Fini Brushed
Description	Detail Rev.	
5412ESSMCH 6" x 4" Cover		
Part Number Numéro Pièce	Rev.	8
5412ESSMCH060404C	0	10

SEE BILL OF MATERIAL ON LAST PAGE

This drawing is confidential and must not be reproduced or used without the consent of EXM

Ce dessin est confidentiel et ne doit pas être reproduit ou utilisé sans le consentement de EXM

STANDARD FEATURES ARE NOT LISTED IN THIS HOLE TABLE			
HOLE TABLE - FRONT VIEW (CUSTOM FEATURE ONLY)			
CUT-OUT	XDIM	YDIM	DESCRIPTION
1	4.080	3.000	LOCK 880 SCQ3MS @ 0.0°
2	1.145	1.125	STANDOFF M6 x 10mm (Inside)

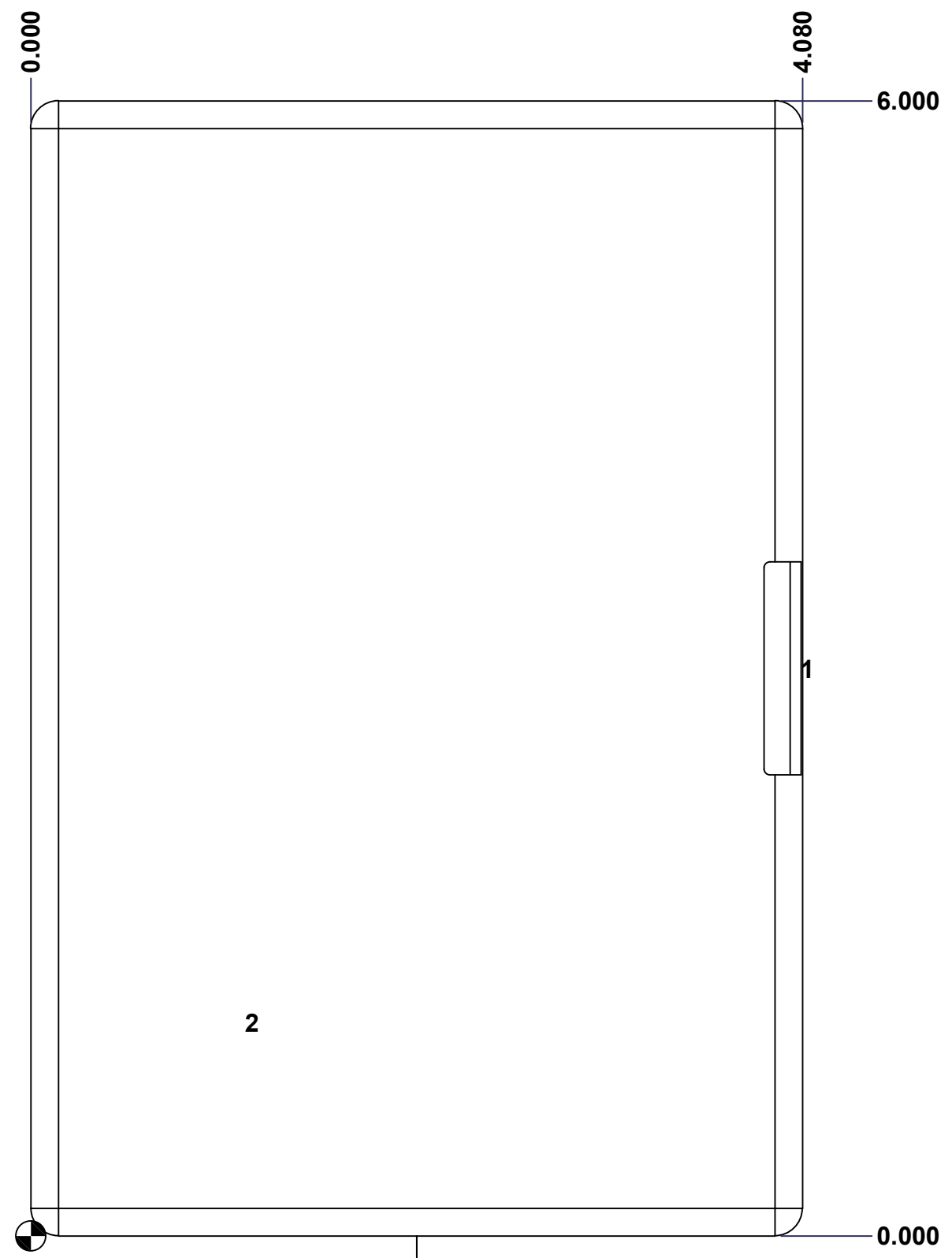

FRONT

	Description	Status
	5412ESSMCH 6" x 4" Cover	(NULL)
	Part Number Numéro Pièce	Rev.
	5412ESSMCH060404C	0
		9
		10

This drawing is confidential and must not be reproduced or used without the consent of EXM

Ce dessin est confidentiel et ne doit pas être reproduit ou utilisé sans le consentement de EXM

No.	Revisions	Date	By/Par

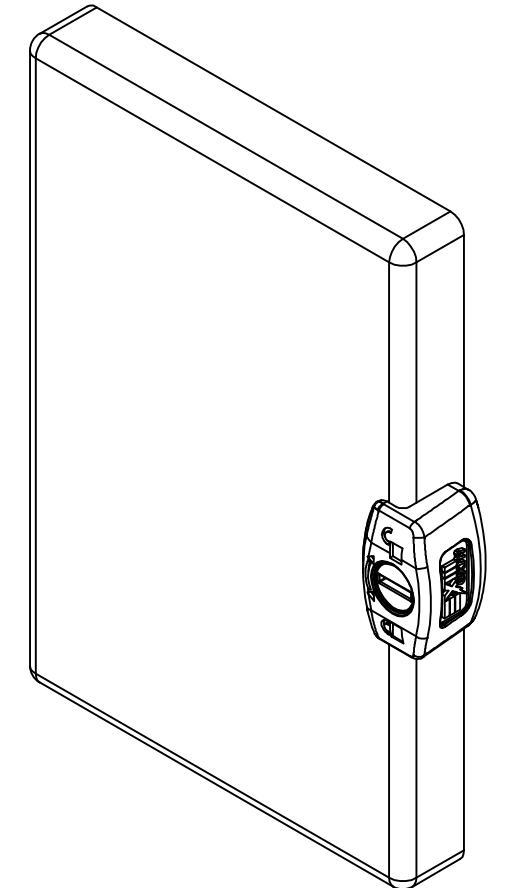

Isometric View

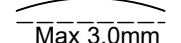
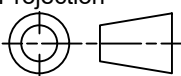

 Tél: (450) 979-4373 Fax: (450) 979-4626 www.exmweb.com		Flatness Aplatissement  Max 3.0mm Projection 
Customer Client	Date	
Drawn By Dessiné Par	BoxCad: BoxCad	Date 18-Nov-14
Material Matière	16 Ga Stainless Steel 304 (1.4mm)	
Color Couleur	Unpainted	Finish Fini Brushed
Description		Detail Rev.
5412ESSMCH 6" x 4" Cover		
Part Number Numéro Pièce	Rev.	10
5412ESSMCH060404C	0	10

Qty	Part Number	Rev	Description
1	5412ESSMCH060404G	0	5412ESSMCH 6" x 4" Gasket
1	STK-Q-08500	4	Stainless Steel Standoff M6 x 10mm
1	880SCQ3S	4	5412 ESSMCH - Stainless Steel External Lock Assy - Slot Lock
1	5412ESSMCH060404C-P	0	5412ESSMCH 6" x 4" Cover Part
2	STK-A-33038	3	5412 ESSMCH - Stainless Steel Hinge
Parts List			

This drawing is confidential and must not be reproduced or used without the consent of EXM

Ce dessin est confidentiel et ne doit pas être reproduit ou utilisé sans le consentement de EXM

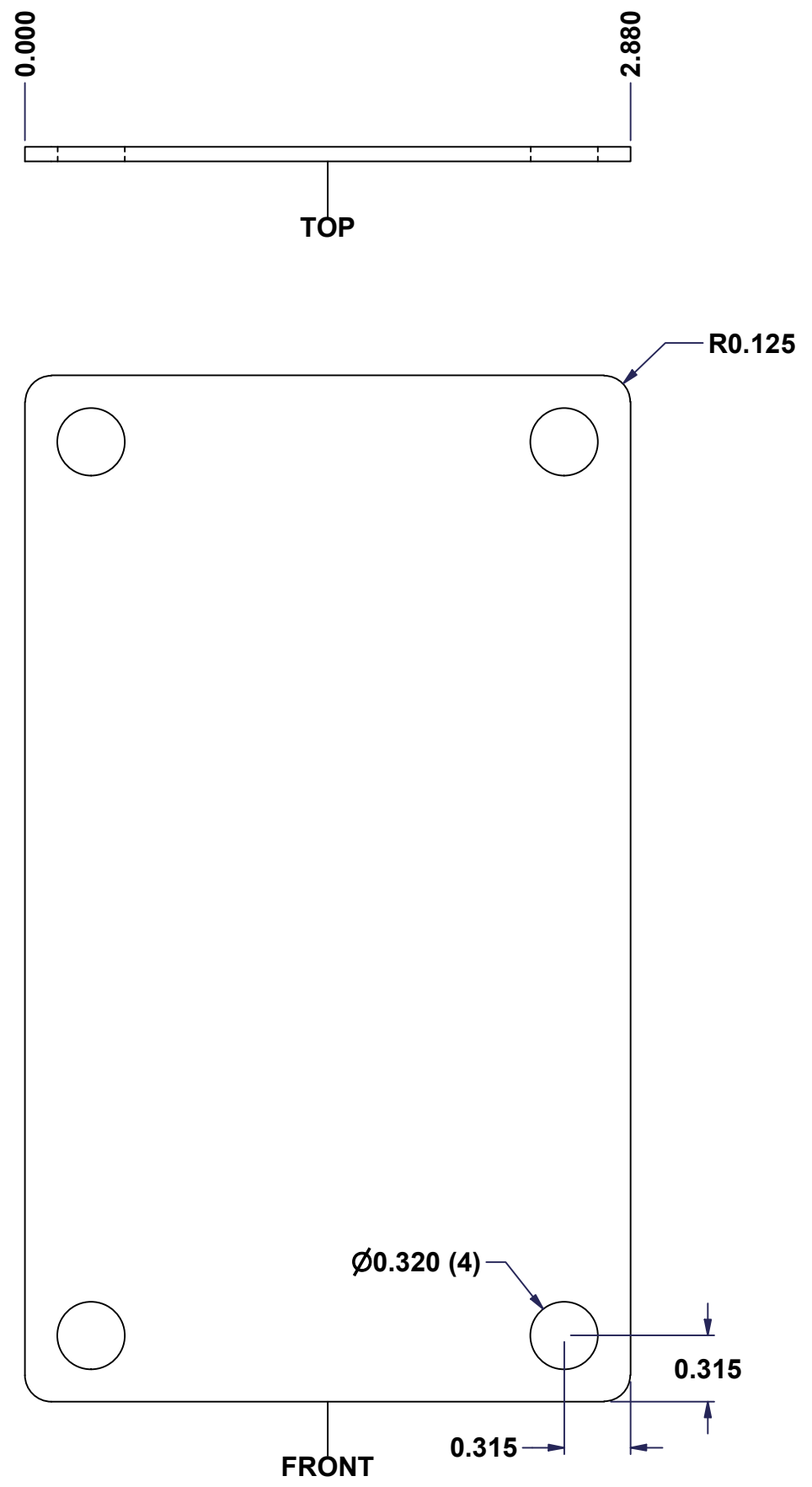

No.	Revisions	Date	By/Par

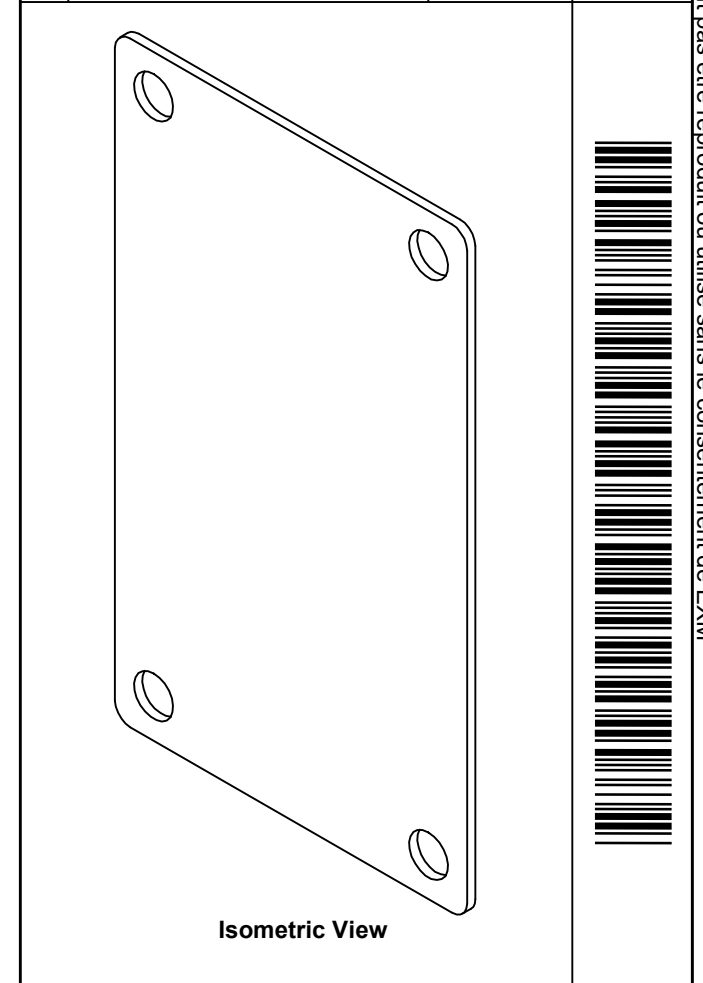

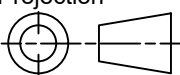
 Tél: (450) 979-4373 Fax: (450) 979-4626 www.exmweb.com		Flatness Aplatissement Max 3.0mm
Customer Client		Projection 
Drawn By / Dessiné Par: BoxCad		Date: 23-Jan-07
Material / Matière: 14 Ga Galvanized (1.7mm)		
Color / Couleur: Unpainted	Finish / Fini: Galvanized	
Description: 880 SP0604G - Inner Panel		Detail Rev.
Part Number / Numéro Pièce: 880 SP0604G		Rev. 1 0

SEE BILL OF MATERIAL ON LAST PAGE

This drawing is confidential and must not be reproduced or used without the consent of EXM

Ce dessin est confidentiel et ne doit pas être reproduit ou utilisé sans le consentement de EXM

No.	Revisions	Date	By/Par

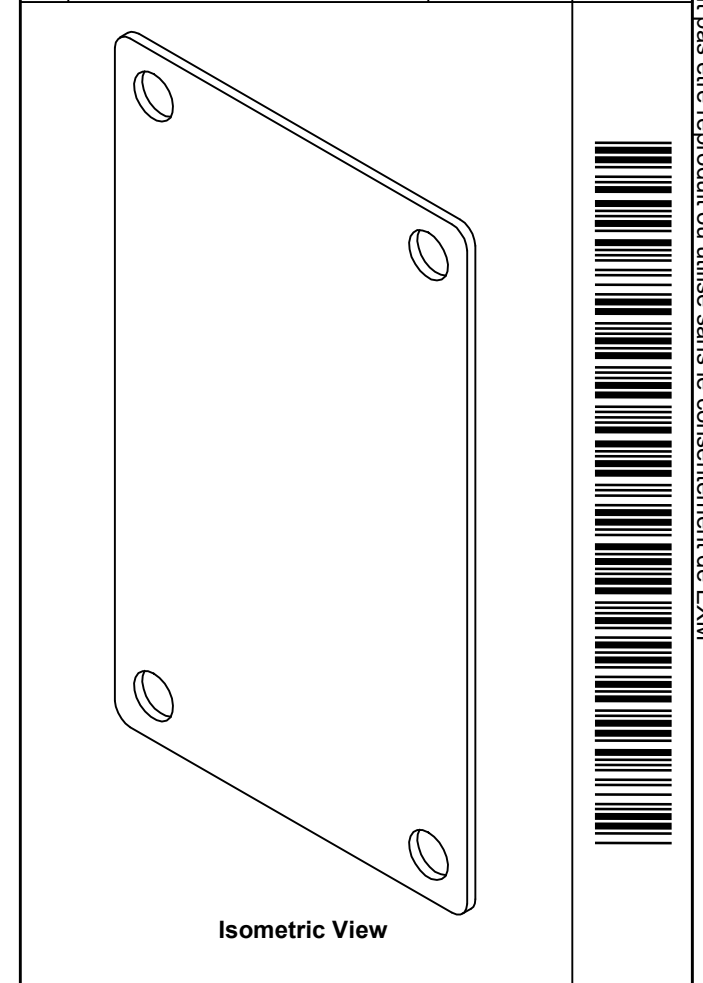

 Tél: (450) 979-4373 Fax: (450) 979-4626 www.exmweb.com		Flatness Aplatissement Max 3.0mm
Customer Client		Date
Drawn By / Dessiné Par: BoxCad		Date: 23-Jan-07
Material / Matière: 14 Ga Galvanized (1.7mm)		
Color / Couleur: Unpainted	Finish / Fini: Galvanized	
Description: 880 SP0604G - Inner Panel		Detail Rev.
Part Number / Numéro Pièce: 880 SP0604G		Rev. 0 / 2

Qty	Part Number	Rev	Description
1	880 SP0604G-P	0	880 SP0604G - Inner Panel Part
Parts List			