

This drawing is confidential and must not be reproduced or used without the consent of EXM

Ce dessin est confidentiel et ne doit pas être reproduit ou utilisé sans le consentement de EXM

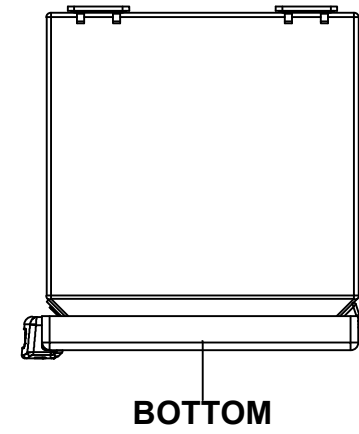
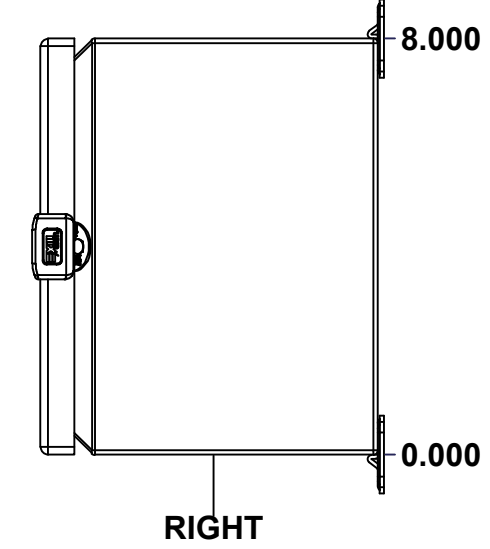
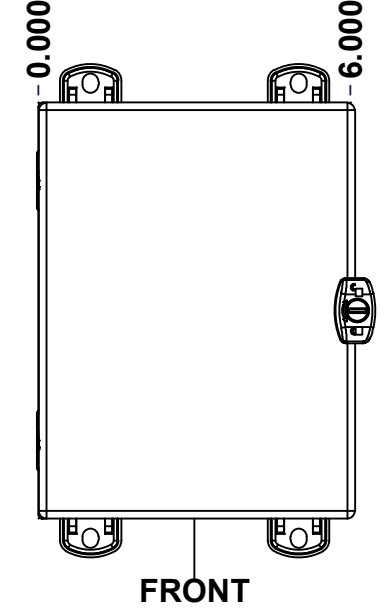
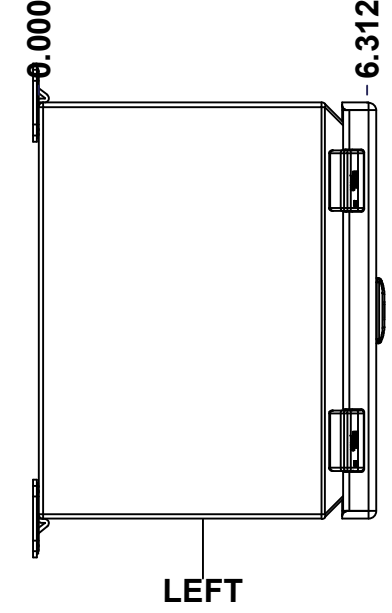
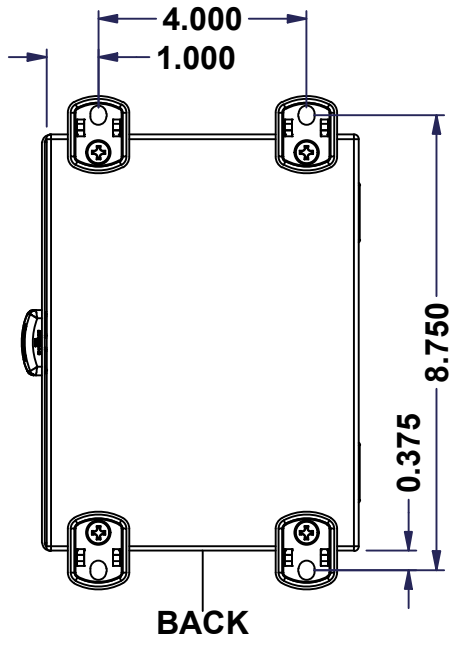
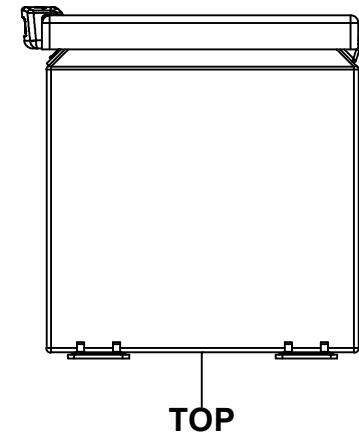

**GRAIN DIRECTION:  
TOP/BOTTOM: HORIZONTAL  
LEFT/RIGHT/BACK/Front: VERTICAL**

**SEE BILL OF MATERIAL ON LAST PAGE**

No.	Revisions	Date	By/Par

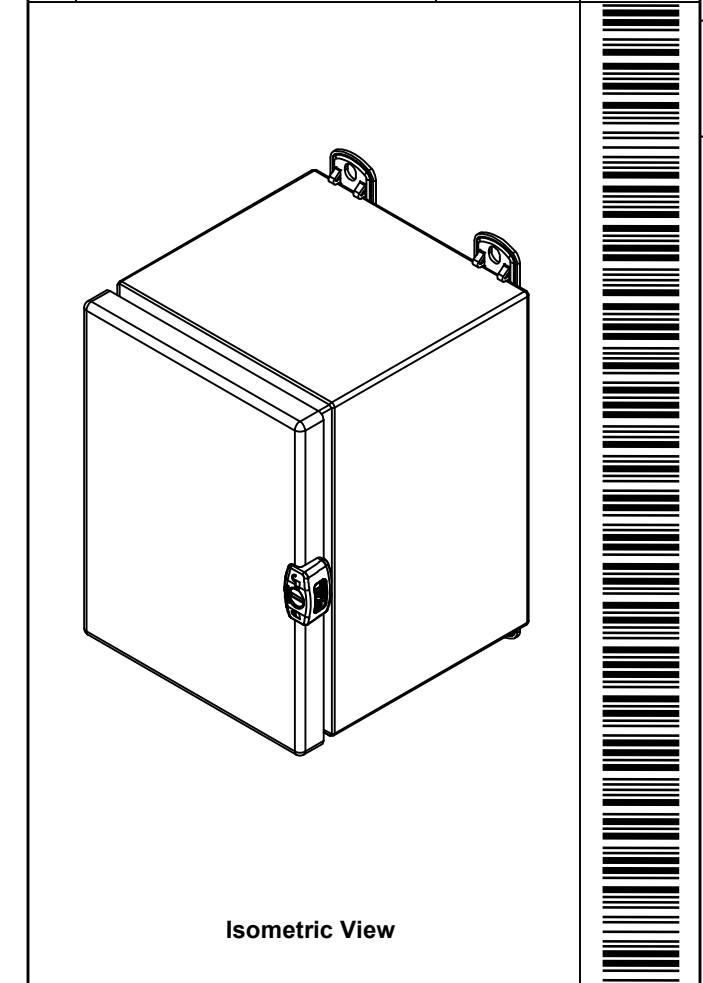

 Tél: (450) 979-4373 Fax: (450) 979-4626 <a href="http://www.exmweb.com">www.exmweb.com</a>		Flatness Aplatissement
		Max 3.0mm
Customer Client		Date
Drawn By Dessiné Par BoxCad: BoxCad		Date 10-Mar-23
Material Matière 16 Ga Stainless Steel 316 (1.4mm)		
Color Couleur Unpainted	Finish Fini Brushed	
Description 5412ESSMCH 8" x 6" x 6" Assembly		Detail Rev.
Part Number Numéro Pièce <b>5412ESSMCH0806066</b>		Rev. 1 <b>0</b>





This drawing is confidential and must not be reproduced or used without the consent of EXM

Ce dessin est confidentiel et ne doit pas être reproduit ou utilisé sans le consentement de EXM

NOTE	
ITEM	DESCRIPTION
1	NEMA 4X Enclosure
2	C/W Standard ground standoffs on box and cover
3	W/O Standard door stiffener
4	C/W Standard inner panel (Included)
5	C/W Standard inner panel mounting standoffs
6	C/W 885 ESCHMF2 Mounting Feet (Kit)

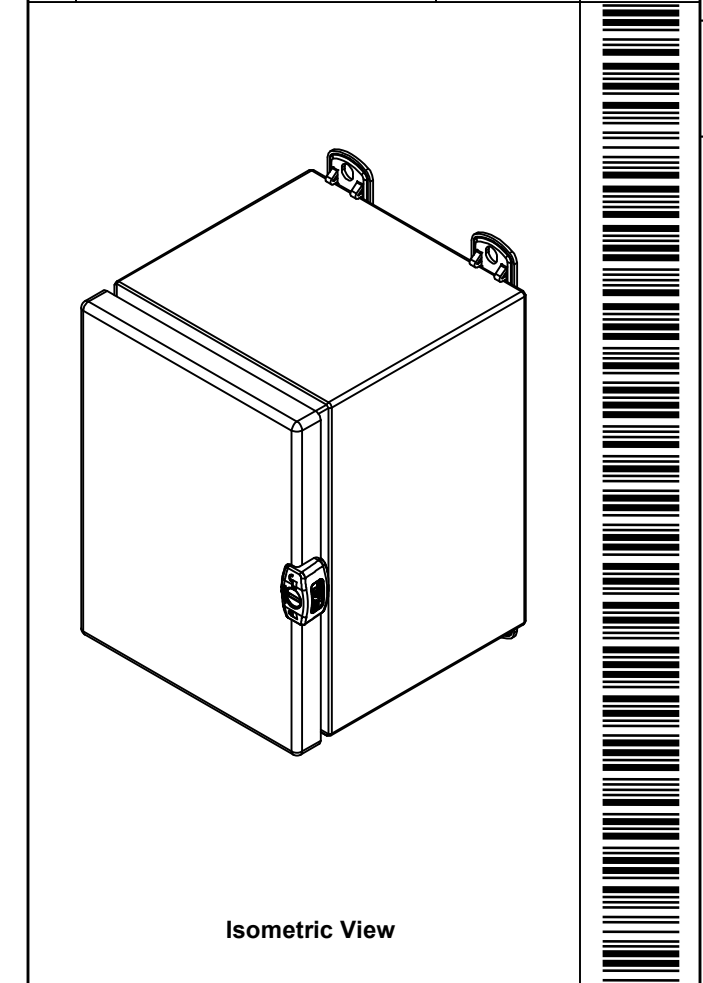
No.	Revisions	Date	By/Par

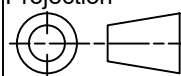

 Tél: (450) 979-4373 Fax: (450) 979-4626 <a href="http://www.exmweb.com">www.exmweb.com</a>		Flatness Aplatissement Max 3.0mm Projection 
Customer Client	Date	
Drawn By Dessiné Par	BoxCad: BoxCad	Date 10-Mar-23
Material Matière	16 Ga Stainless Steel 316 (1.4mm)	
Color Couleur	Unpainted	Finish Fini Brushed
Description	Detail Rev.	
5412ESSMCH 8" x 6" x 6" Assembly		
Part Number Numéro Pièce	5412ESSMCH0806066	Rev. 2 0 9

PACKING		
ITEM	QTY	DESCRIPTION
STK-E-04307	1	CARTON 5412 ESCH080606
Plastic bag	1	To protect cover surface and inside gasket
Packaging label	1	White label with product number
STK-S-01100	1	ESCH EXM SQUARE STICKER

Qty	Part Number	Rev	Description
1	5412ESSMCH080606C	0	5412ESSMCH 8" x 6" Cover
1	880 SP0806G	0	880 SP0806G - Inner Panel
1	STK-K-02945	0	5412 ESSMCH Accessory Kit
1	5412ESSMCH080606B	0	5412ESSMCH 8" x 6" x 6" Body
2	STK-Q-08100	1	M5 Nylon Insert Lock Nut
2	STK-Q-10249	0	M5 Sealing Washer
Parts List			

This drawing is confidential and must not be reproduced or used without the consent of EXM

Ce dessin est confidentiel et ne doit pas être reproduit ou utilisé sans le consentement de EXM

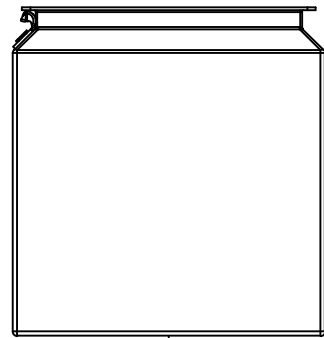

TOP

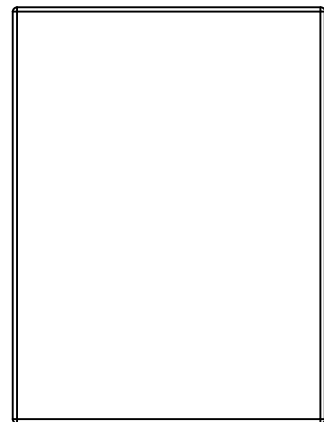

BACK

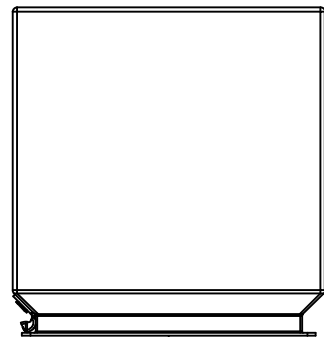

BOTTOM

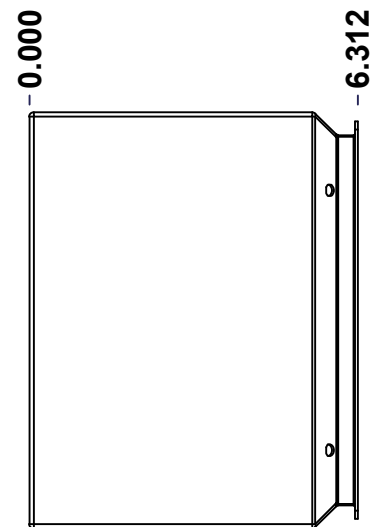

LEFT

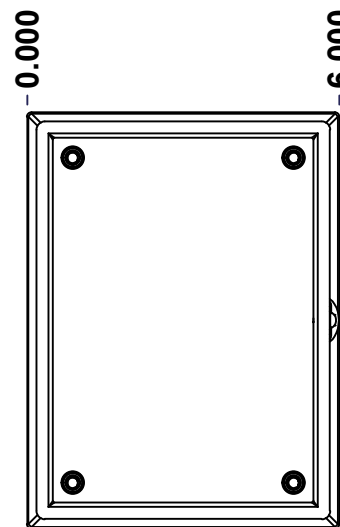

FRONT

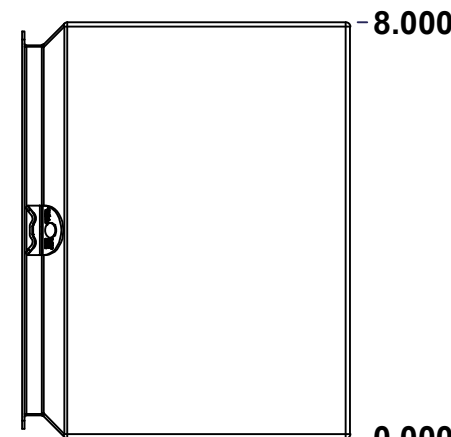

RIGHT

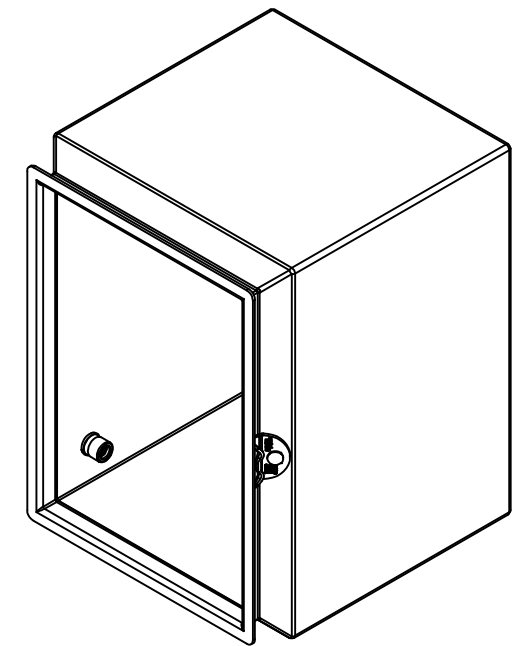

Isometric View



Tél: (450) 979-4373  
 Fax: (450) 979-4626  
[www.exmweb.com](http://www.exmweb.com)

Flatness  
Aplatissement

Max 3.0mm

Projection

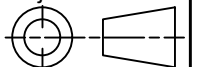

Customer Client	Date
Drawn By Dessiné Par BoxCad: BoxCad	Date 10-Mar-23
Material Matière 16 Ga Stainless Steel 316 (1.4mm)	
Color Couleur Unpainted	Finish Fini Brushed
Description 5412ESSMCH 8" x 6" x 6" Body	Detail Rev.
Part Number Numéro Pièce 5412ESSMCH0806066B	Rev. 3 0

SEE BILL OF MATERIAL ON LAST PAGE

This drawing is confidential and must not be reproduced or used without the consent of EXM

Ce dessin est confidentiel et ne doit pas être reproduit ou utilisé sans le consentement de EXM

STANDARD FEATURES ARE NOT LISTED IN THIS HOLE TABLE			
HOLE TABLE - LEFT VIEW (CUSTOM FEATURE ONLY)			
CUT-OUT	XDIM	YDIM	DESCRIPTION
1	4.625	0.875	STANDOFF M6 x 10mm (Inside)

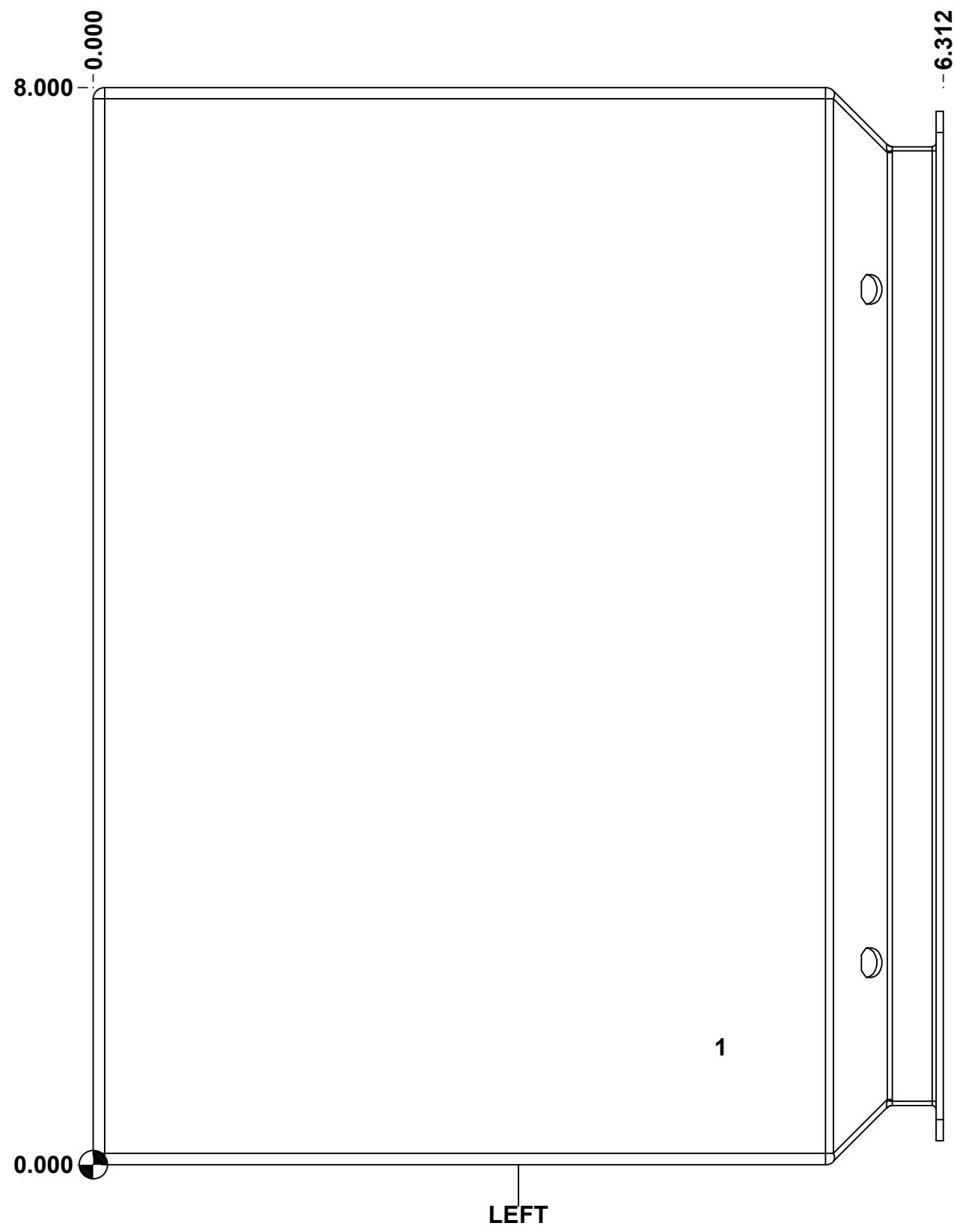

	Description	Status
	5412ESSMCH 8" x 6" x 6" Body	(NULL)
Part Number Numéro Pièce <b>5412ESSMCH0806066B</b>	Rev.	4
	<b>0</b>	9

This drawing is confidential and must not be reproduced or used without the consent of EXM

Ce dessin est confidentiel et ne doit pas être reproduit ou utilisé sans le consentement de EXM

**STANDARD FEATURES ARE NOT LISTED IN THIS HOLE TABLE**

**HOLE TABLE - BACK VIEW (CUSTOM FEATURE ONLY)**

CUT-OUT	XDIM	YDIM	DESCRIPTION
1	0.875	0.875	IP STANDOFF M6 x 10mm (Inside)
2	0.875	7.125	IP STANDOFF M6 x 10mm (Inside)
3	5.125	7.125	IP STANDOFF M6 x 10mm (Inside)
4	5.125	0.875	IP STANDOFF M6 x 10mm (Inside)
-----			
5	5.000	0.000	FOOT 885 ESCHMF2
6	1.000	0.000	FOOT 885 ESCHMF2
7	5.000	8.000	FOOT 885 ESCHMF2
8	1.000	8.000	FOOT 885 ESCHMF2

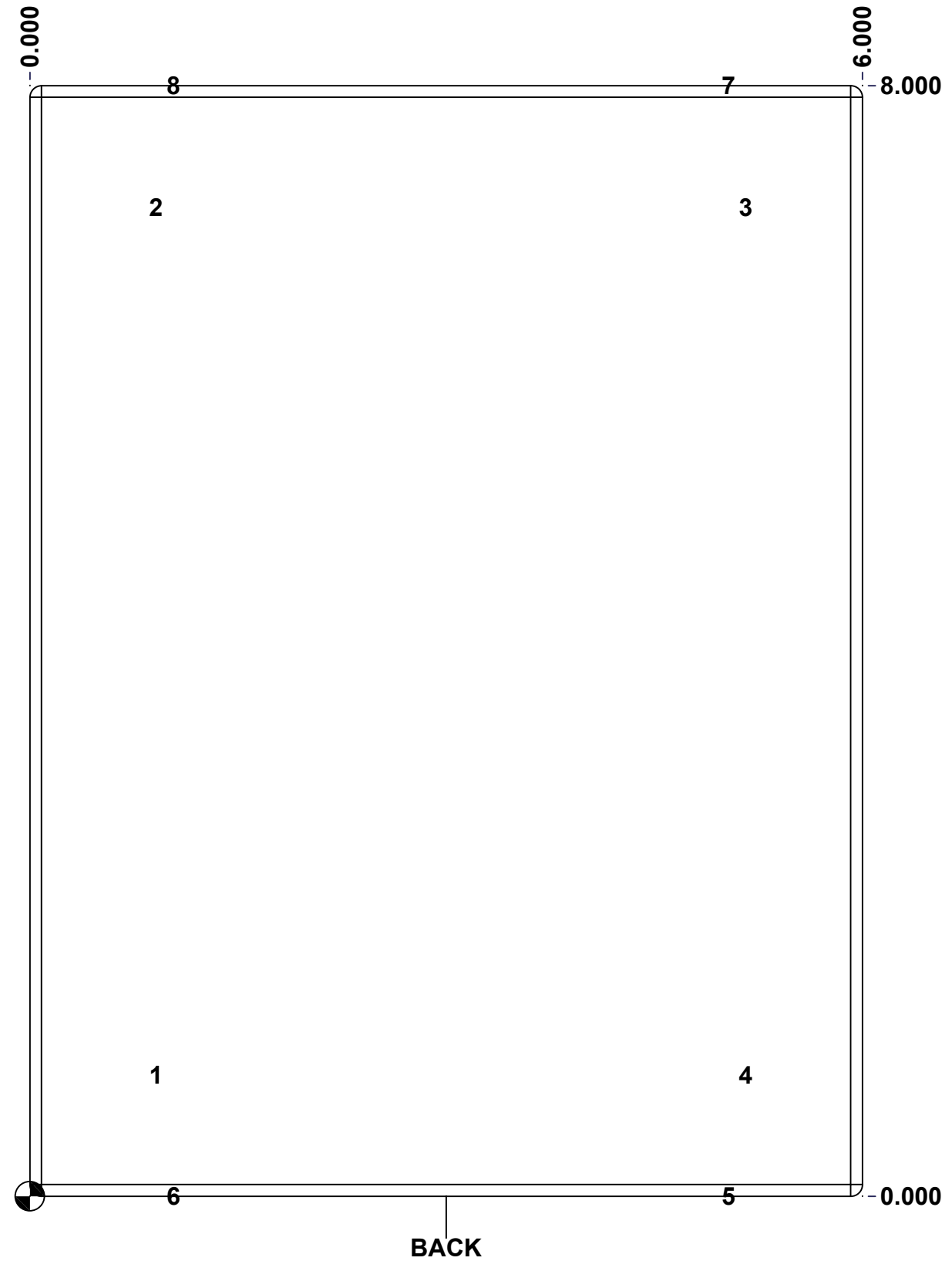

	Description	Status
	5412ESSMCH 8" x 6" x 6" Body	(NULL)
	Part Number Numéro Pièce	Rev.
	<b>5412ESSMCH0806066B</b>	<b>0</b>
		5
		9

This drawing is confidential and must not be reproduced or used without the consent of EXM

Ce dessin est confidentiel et ne doit pas être reproduit ou utilisé sans le consentement de EXM

No.	Revisions	Date	By/Par

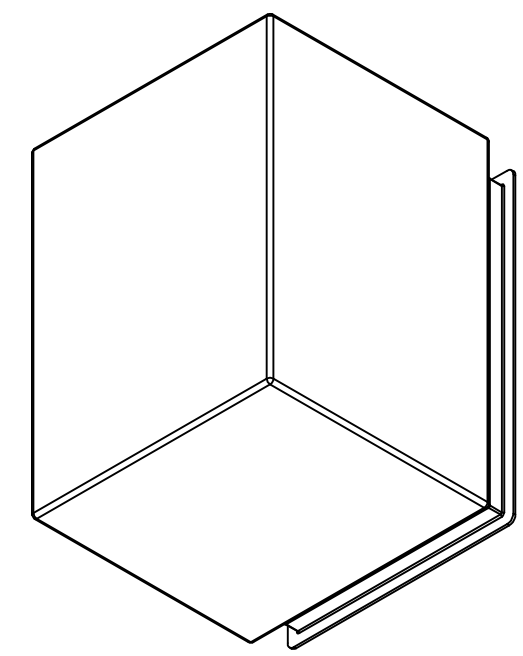

Isometric View



 Tél: (450) 979-4373 Fax: (450) 979-4626 <a href="http://www.exmweb.com">www.exmweb.com</a>		Flatness Aplatissement Max 3.0mm
Customer Client		Date
Drawn By Dessiné Par BoxCad: BoxCad		Date 10-Mar-23
Material Matière 16 Ga Stainless Steel 316 (1.4mm)		
Color Couleur Unpainted	Finish Fini Brushed	
Description 5412ESSMCH 8" x 6" x 6" Body		Detail Rev.
Part Number Numéro Pièce <b>5412ESSMCH0806066B</b>		Rev. <b>0</b>

Qty	Part Number	Rev	Description
1	STK-Q-08100	1	M5 Nylon Insert Lock Nut
1	5412ESSMCH0806066B-P	0	5412ESSMCH 8" x 6" x 6" Body Part
1	STK-A-70469	6	5412 ESSMCH - Stainless Steel 316 Body Catch Assembly
5	STK-Q-08500	4	Stainless Steel Standoff M6 x 10mm
Parts List			

6
9

This drawing is confidential and must not be reproduced or used without the consent of EXM

Ce dessin est confidentiel et ne doit pas être reproduit ou utilisé sans le consentement de EXM

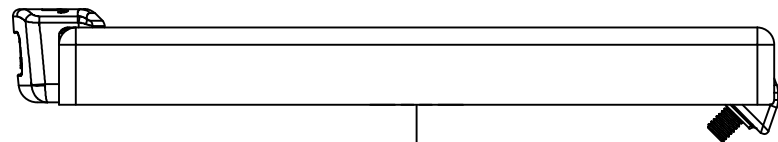

TOP

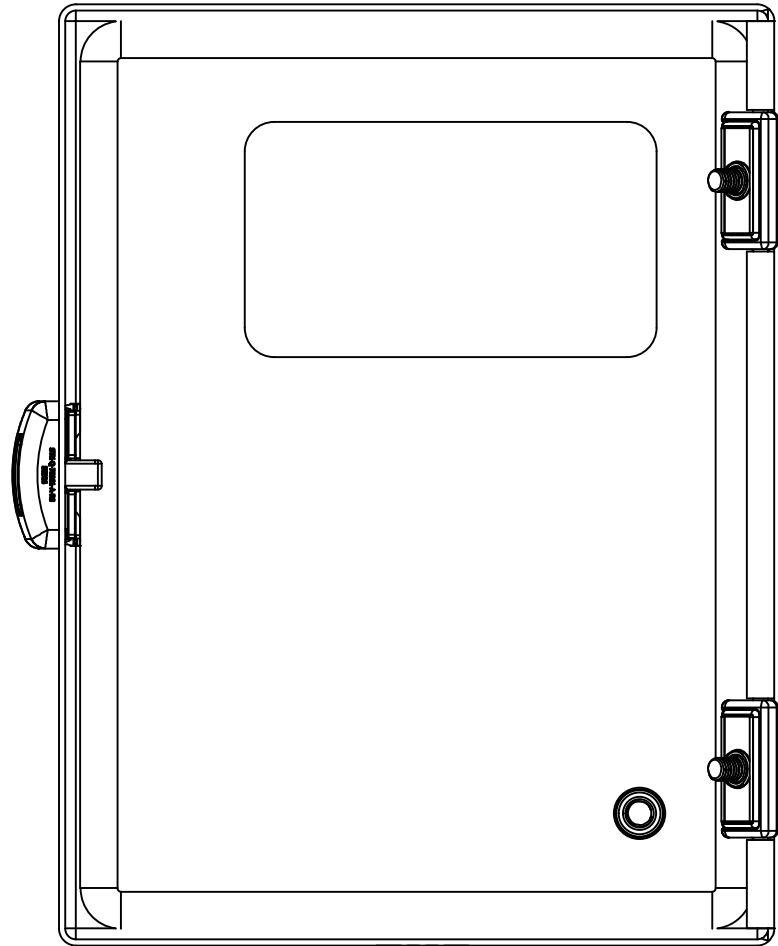

BACK

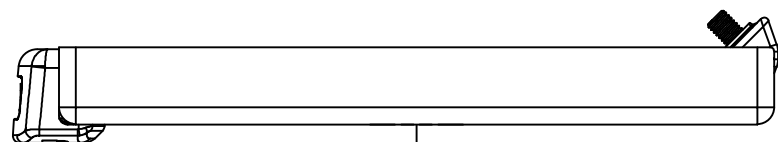

BOTTOM



LEFT

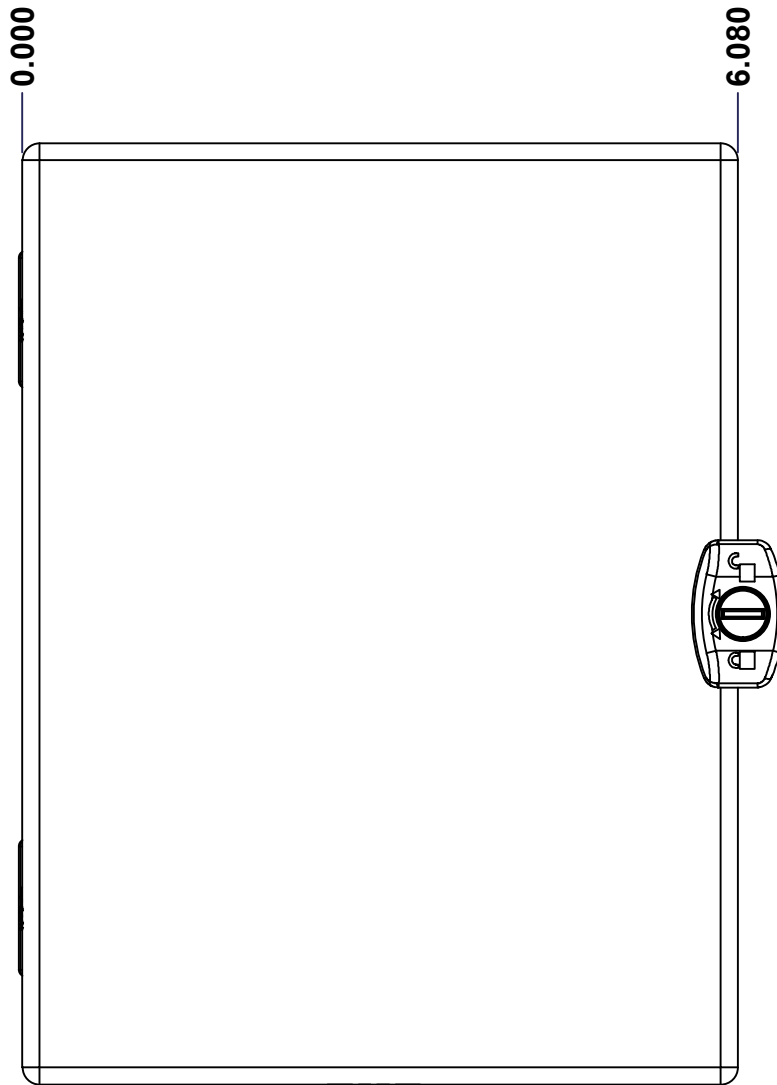

FRONT

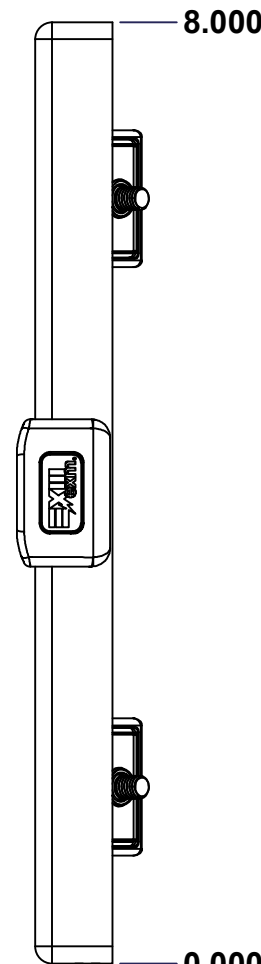

RIGHT

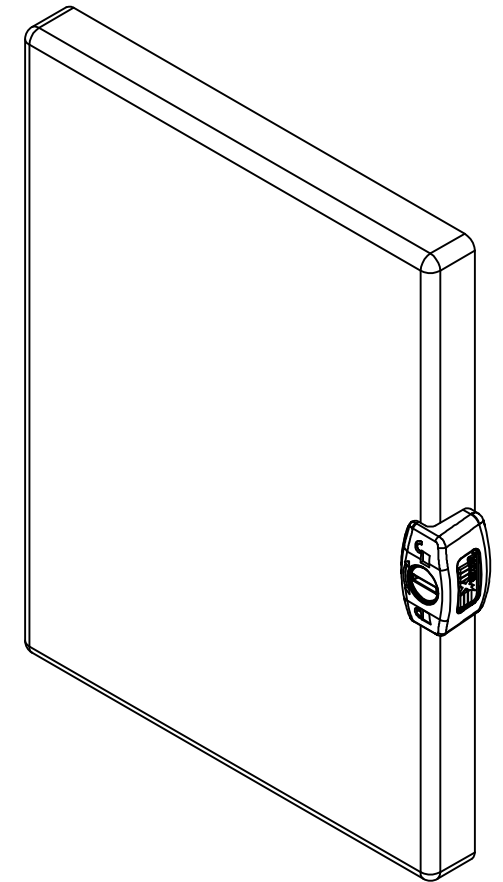

Isometric View

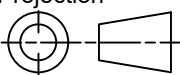

No.	Revisions	Date	By/Par

 Tél: (450) 979-4373 Fax: (450) 979-4626 <a href="http://www.exmweb.com">www.exmweb.com</a>		Flatness Aplatissement Max 3.0mm Projection 
Customer Client	Date	
Drawn By Dessiné Par	BoxCad: BoxCad	Date 10-Mar-23
Material Matière	16 Ga Stainless Steel 316 (1.4mm)	
Color Couleur	Unpainted	Finish Fini Brushed
Description 5412ESSMCH 8" x 6" Cover		Detail Rev.
Part Number Numéro Pièce	Rev. 0	7 9

SEE BILL OF MATERIAL ON LAST PAGE

**5412ESSMCH0806066C**

This drawing is confidential and must not be reproduced or used without the consent of EXM

Ce dessin est confidentiel et ne doit pas être reproduit ou utilisé sans le consentement de EXM

STANDARD FEATURES ARE NOT LISTED IN THIS HOLE TABLE			
HOLE TABLE - FRONT VIEW (CUSTOM FEATURE ONLY)			
CUT-OUT	XDIM	YDIM	DESCRIPTION
1	1.145	1.125	STANDOFF M6 x 10mm (Inside)
2	2.750	6.000	LABEL_EXM
3	6.080	4.000	LOCK 880 SCQ3MS @ 0.0°

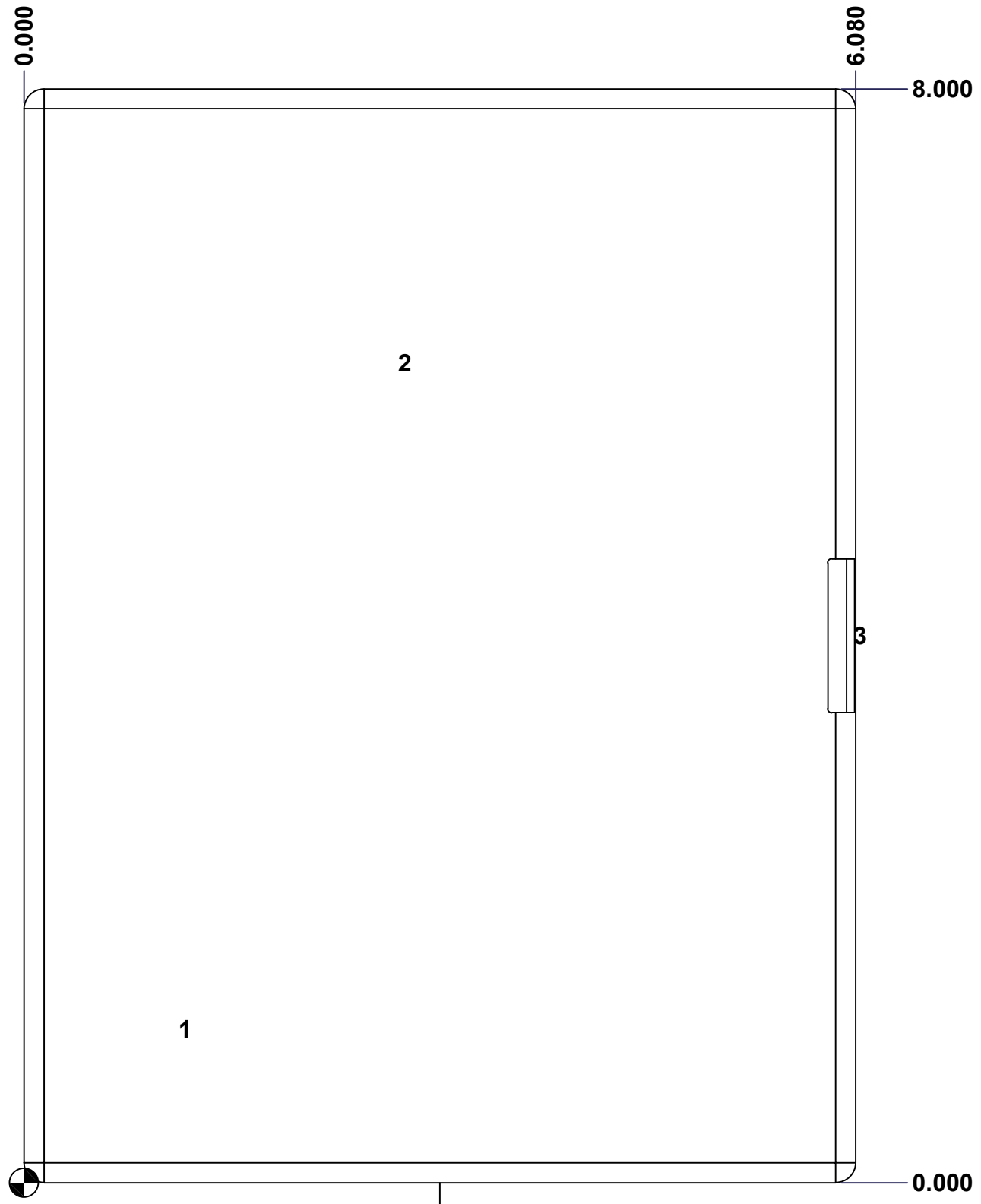

FRONT

	Description	Status	
	5412ESSMCH 8" x 6" Cover	(NULL)	
	Part Number Numéro Pièce	Rev.	
	<b>5412ESSMCH0806066C</b>	<b>0</b>	8/9



This drawing is confidential and must not be reproduced or used without the consent of EXM

Ce dessin est confidentiel et ne doit pas être reproduit ou utilisé sans le consentement de EXM

No.	Revisions	Date	By/Par

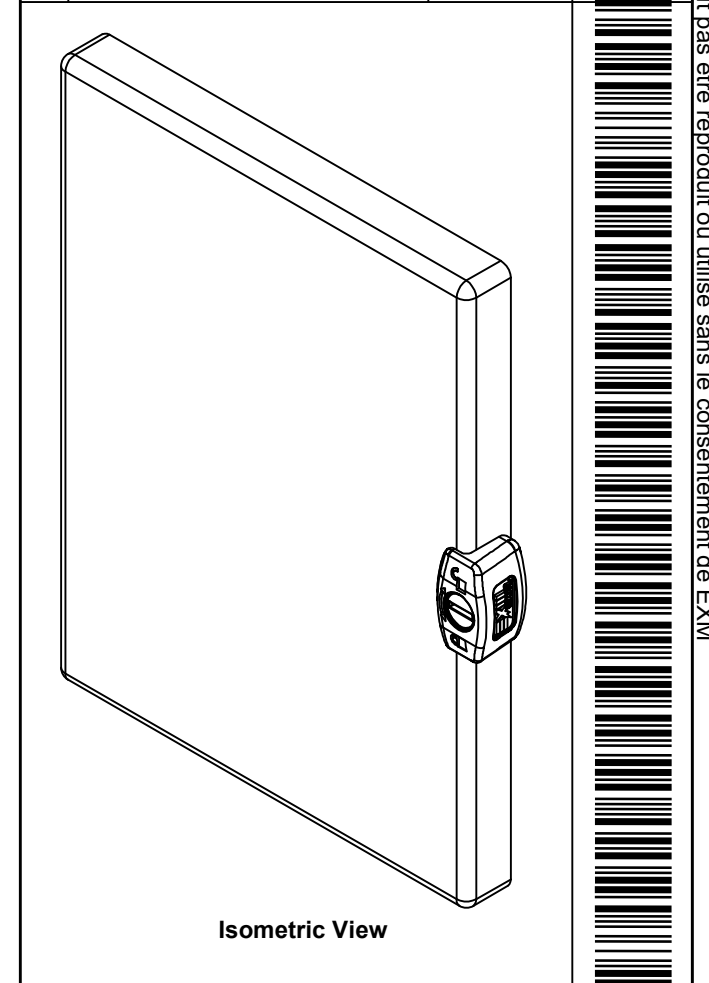

**EXM**  
exm

Tél: (450) 979-4373  
Fax: (450) 979-4626  
[www.exmweb.com](http://www.exmweb.com)

Flatness  
Aplatissement  
Max 3.0mm

Projection

Customer Client	Date
Drawn By / Dessiné Par: BoxCad: BoxCad	Date: 10-Mar-23

Material / Matière: 16 Ga Stainless Steel 316 (1.4mm)

Color / Couleur: Unpainted	Finish / Fini: Brushed
----------------------------	------------------------

Description: 5412ESSMCH 8" x 6" Cover	Detail Rev.
---------------------------------------	-------------

Part Number / Numéro Pièce: <b>5412ESSMCH0806066C</b>	Rev. / Révis: <b>0</b>	9
---	------------------------	---

Qty	Part Number	Rev	Description
1	5412ESSMCH0806066G	0	5412ESSMCH 8" x 6" Gasket
1	880SCQ3S	4	5412 ESSMCH - Stainless Steel External Lock Assy - Slot Lock
1	STK-S-00100	0	3.5" x 2" Silver Milar Flexcon Sticker
1	STK-Q-08500	4	Stainless Steel Standoff M6 x 10mm
1	5412ESSMCH0806066C-P	0	5412ESSMCH 8" x 6" Cover Part
2	STK-A-33038	3	5412 ESSMCH - Stainless Steel Hinge
Parts List			

This drawing is confidential and must not be reproduced or used without the consent of EXM

Ce dessin est confidentiel et ne doit pas être reproduit ou utilisé sans le consentement de EXM

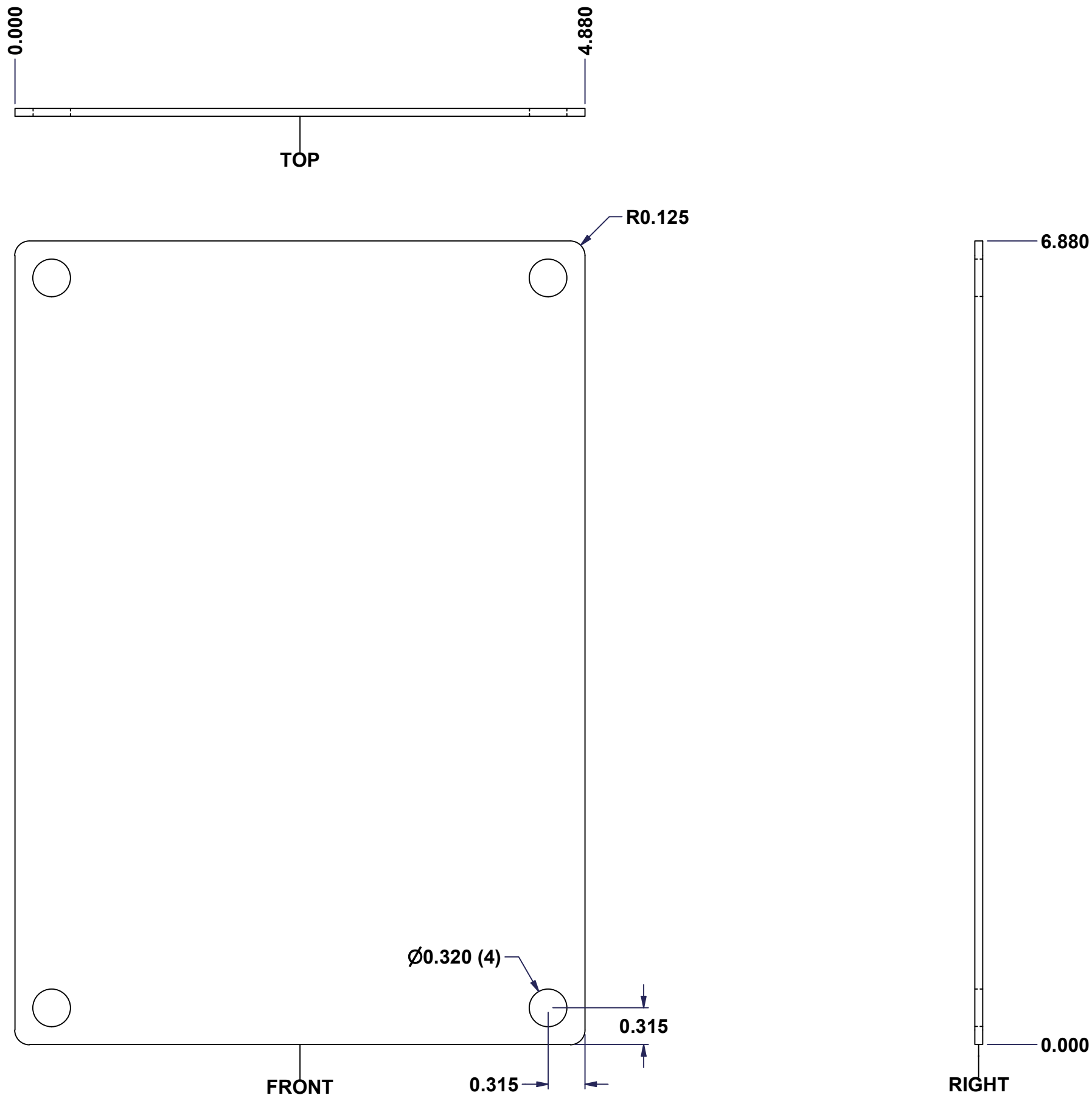

No.	Revisions	Date	By/Par

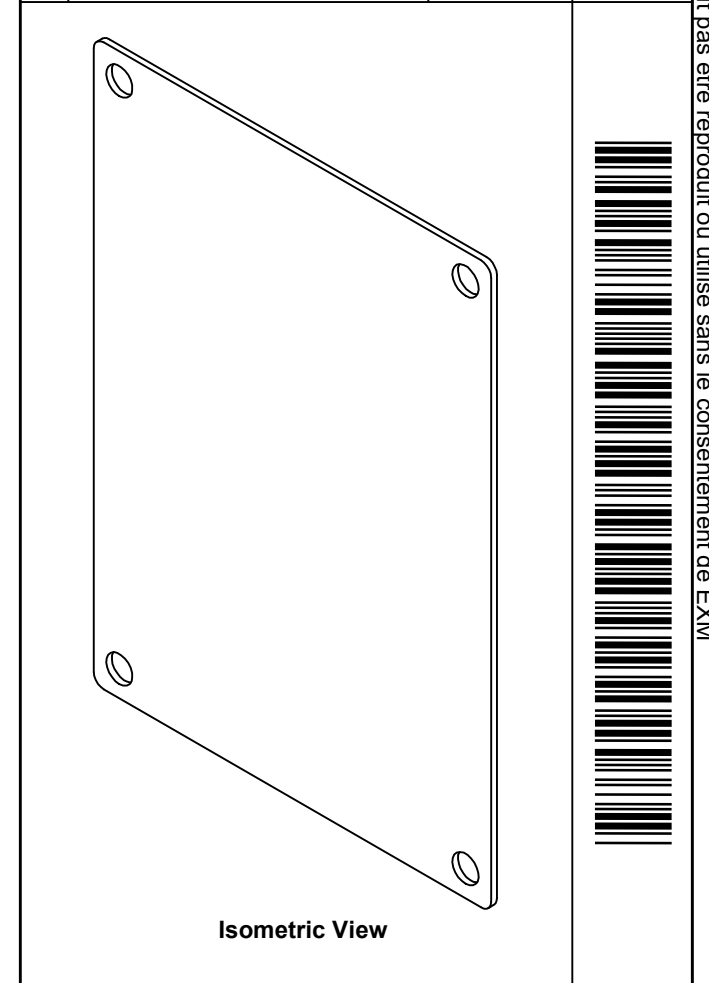

Tél: (450) 979-4373 Fax: (450) 979-4626 www.exmweb.com		Flatness Aplatissement Max 3.0mm Projection 
Customer Client	Date	
Drawn By Dessiné Par: BoxCad	Date: 23-Jan-07	
Material Matière: 14 Ga Galvanized (1.7mm)		
Color Couleur: Unpainted	Finish Fini: Galvanized	
Description: 880 SP0806G - Inner Panel		Detail Rev.
Part Number Numéro Pièce: 880 SP0806G	Rev. 0	1/2

SEE BILL OF MATERIAL ON LAST PAGE

This drawing is confidential and must not be reproduced or used without the consent of EXM

Ce dessin est confidentiel et ne doit pas être reproduit ou utilisé sans le consentement de EXM

No.	Revisions	Date	By/Par

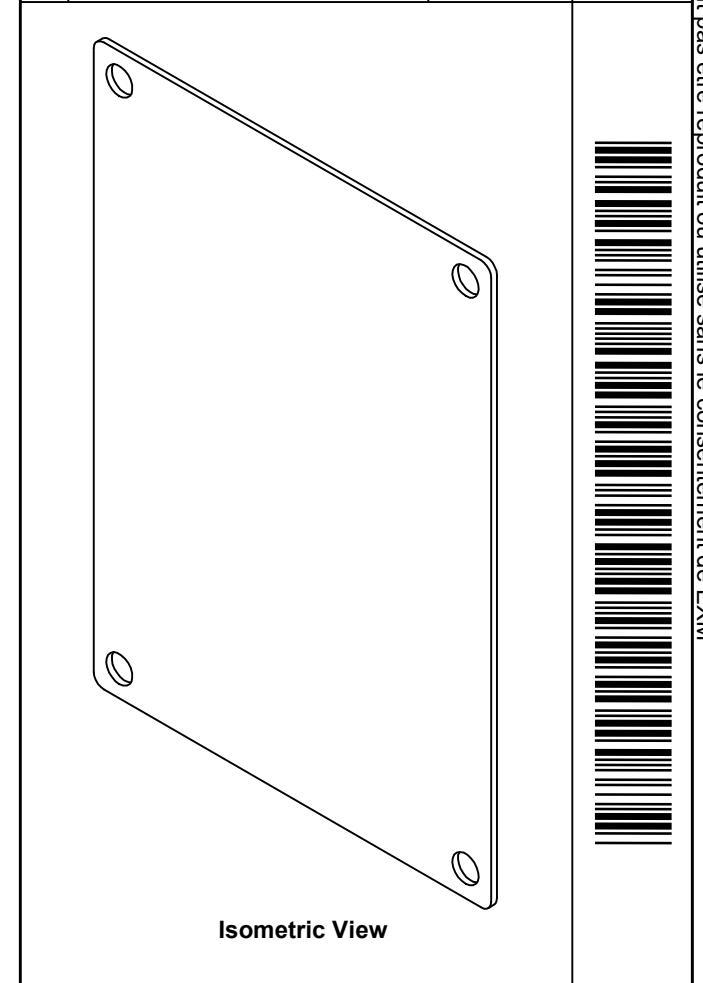

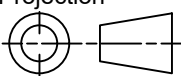
 Tél: (450) 979-4373 Fax: (450) 979-4626 www.exmweb.com		Flatness Aplatissement Max 3.0mm
Customer Client		Projection 
Drawn By / Dessiné Par: BoxCad		Date: 23-Jan-07
Material / Matière: 14 Ga Galvanized (1.7mm)		
Color / Couleur: Unpainted	Finish / Fini: Galvanized	
Description: 880 SP0806G - Inner Panel		Detail Rev.
Part Number / Numéro Pièce: <b>880 SP0806G</b>		Rev. 0 / 2

Qty	Part Number	Rev	Description
1	880 SP0806G-P	0	880 SP0806G - Inner Panel Part
Parts List			