

This drawing is confidential and must not be reproduced or used without the consent of EXM

Ce dessin est confidentiel et ne doit pas être reproduit ou utilisé sans le consentement de EXM

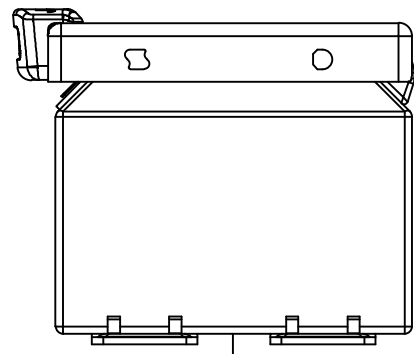

TOP

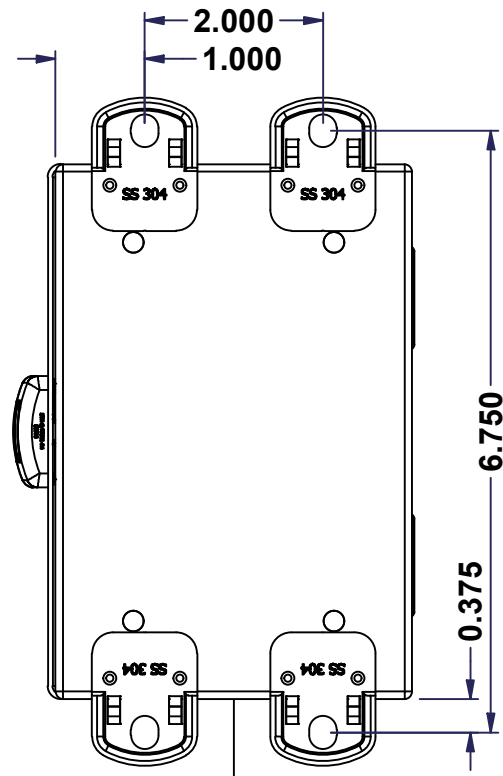

BACK

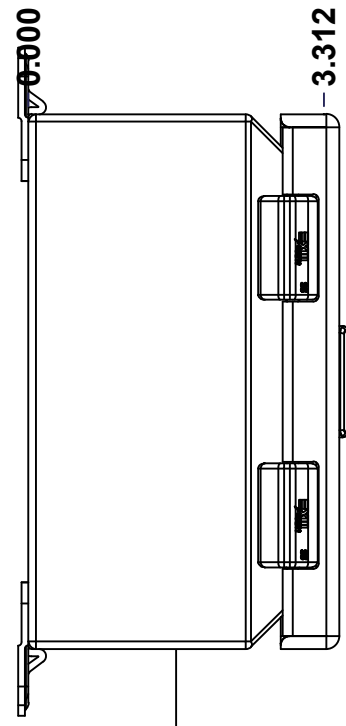

LEFT

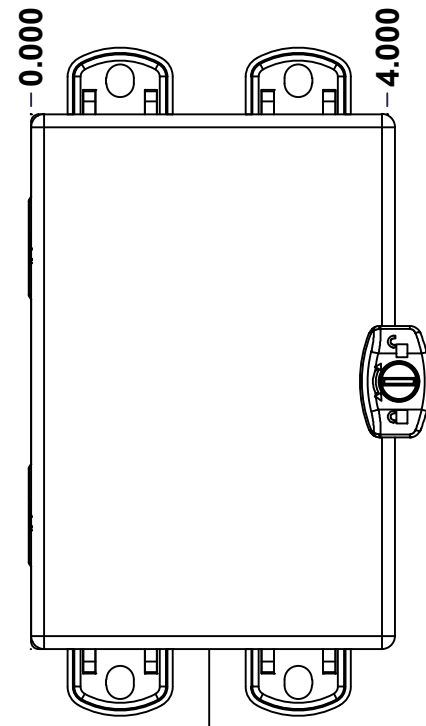

FRONT

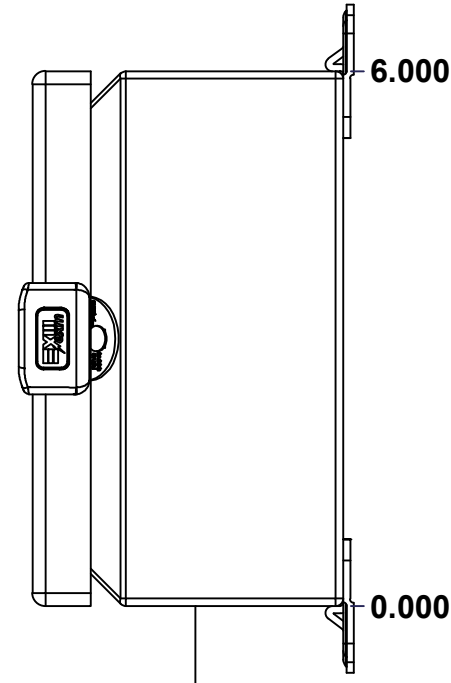

RIGHT

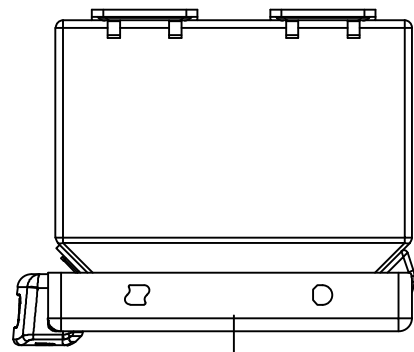

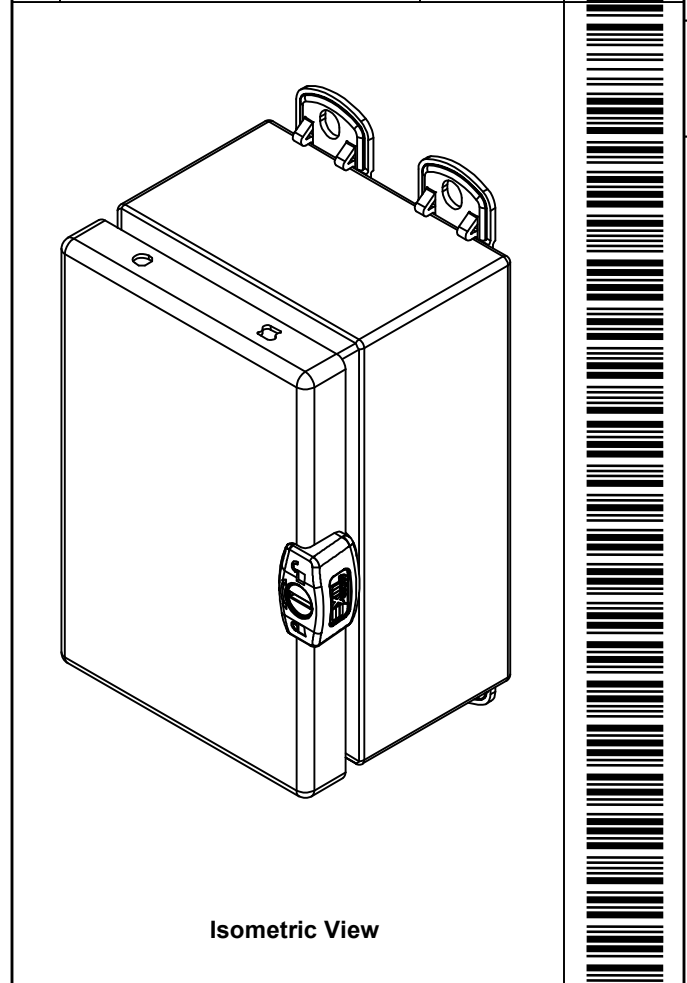

BOTTOM

No.	Revisions	Date	By/Par



Isometric View

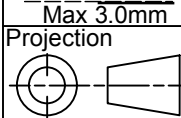

 Tél: (450) 979-4373 Fax: (450) 979-4626 <a href="http://www.exmweb.com">www.exmweb.com</a>		Flatness Aplatissement  Max 3.0mm Projection 
Customer Client		Date
Drawn By Dessiné Par	BoxCad: BoxCad	Date 10-Mar-23
Material Matière	16 Ga Stainless Steel 304 (1.4mm)	
Color Couleur	Asa-61 Grey	Finish Fini Smooth
Description	Detail Rev.	
5412ESSMPCH 6" x 4" x 3" Assembly		
Part Number Numéro Pièce	Rev. 1	10
SEE BILL OF MATERIAL ON LAST PAGE 5412ESSMPCH060403NOIP		0

This drawing is confidential and must not be reproduced or used without the consent of EXM

Ce dessin est confidentiel et ne doit pas être reproduit ou utilisé sans le consentement de EXM

NOTE	
ITEM	DESCRIPTION
1	NEMA 4X Enclosure
2	C/W Standard ground standoffs on box and cover
3	W/O Standard door stiffener
4	W/O Inner panel
5	C/W Standard inner panel mounting standoffs
6	C/W 885 ESCHMF2 Mounting Feet (Welded)

No.	Revisions	Date	By/Par

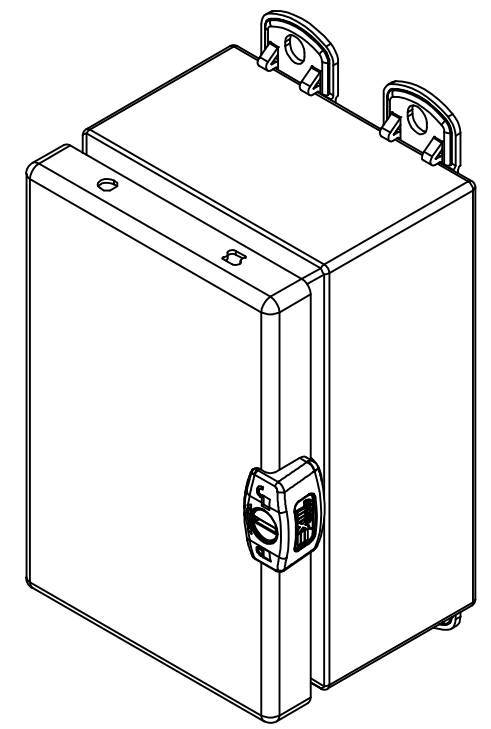

Isometric View

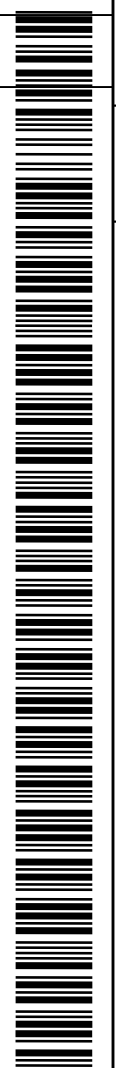

Tél: (450) 979-4373  
 Fax: (450) 979-4626  
[www.exmweb.com](http://www.exmweb.com)

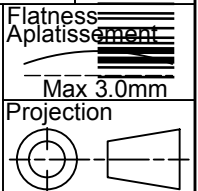

Customer Client	Date
Drawn By Dessiné Par BoxCad: BoxCad	Date 10-Mar-23

Material Matière 16 Ga Stainless Steel 304 (1.4mm)

Color Couleur	Asa-61 Grey	Finish Fini	Smooth
---------------	-------------	-------------	--------

Description 5412ESSMPCH 6" x 4" x 3" Assembly

Part Number Numéro Pièce	Rev.	2
<b>5412ESSMPCH060403NOIP</b>	<b>0</b>	10

PACKING		
ITEM	QTY	DESCRIPTION
STK-E-04301	1	CARTON 5412 ESCH060403
Plastic bag	1	To protect cover surface and inside gasket
Packaging label	1	White label with product number
STK-S-01100	1	ESCH EXM SQUARE STICKER

Qty	Part Number	Rev	Description
1	STK-K-02910	3	5412 ESCH Accessory Kit
1	5412ESSMPCH060403NO IPC	0	5412ESSMPCH 6" x 4" Cover
1	5412ESSMPCH060403NO IPB	0	5412ESSMPCH 6" x 4" x 3" Body
2	STK-Q-08100	1	M5 Nylon Insert Lock Nut
2	STK-Q-10249	0	M5 Sealing Washer

Parts List

This drawing is confidential and must not be reproduced or used without the consent of EXM

Ce dessin est confidentiel et ne doit pas être reproduit ou utilisé sans le consentement de EXM

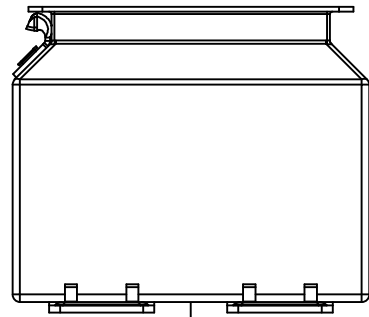

TOP

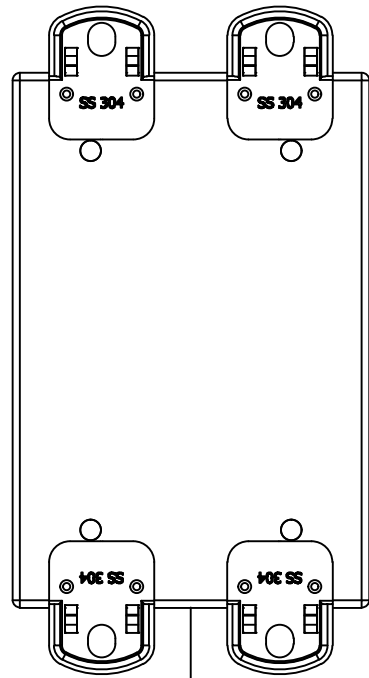

BACK

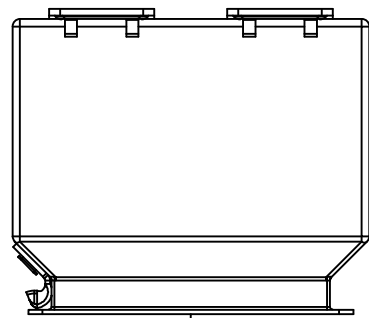

BOTTOM

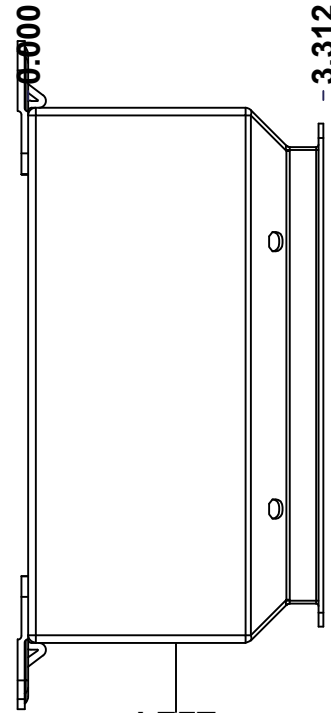

LEFT

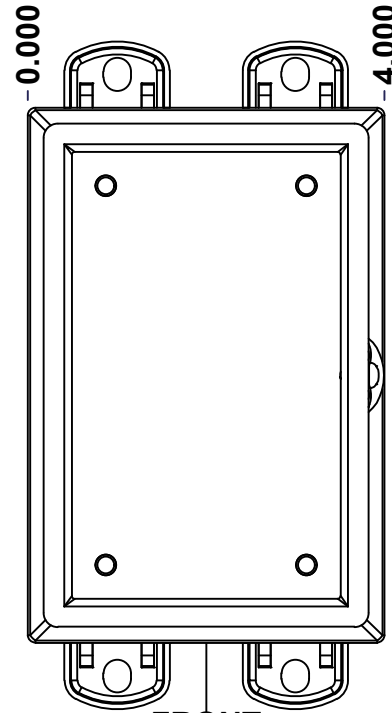

FRONT

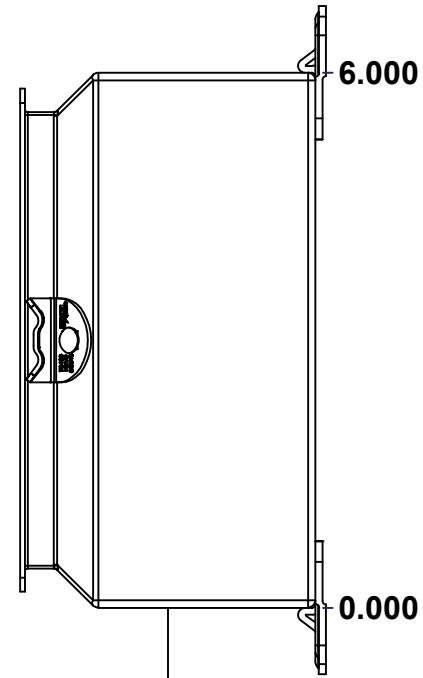

RIGHT

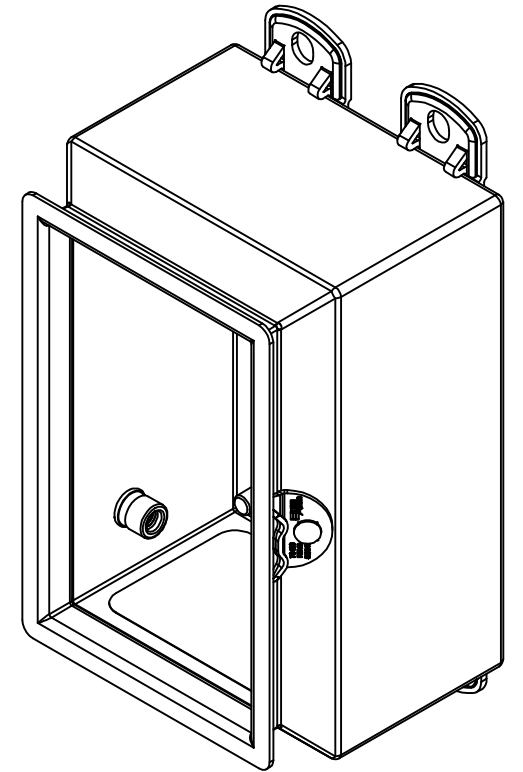

Isometric View



No.	Revisions	Date	By/Par

  

	Flatness Aplatissement Max 5.0mm Projection
	Tél: (450) 979-4373 Fax: (450) 979-4626 <a href="http://www.exmweb.com">www.exmweb.com</a>
Customer Client	Date
Drawn By Dessiné Par BoxCad: BoxCad	Date 10-Mar-23
Material Matière 16 Ga Stainless Steel 304 (1.4mm)	
Color Couleur Asa-61 Grey	Finish Fini Smooth
Description 5412ESSMPCH 6" x 4" x 3" Body	Detail Rev.
Part Number Numéro Pièce	Rev. 3

This drawing is confidential and must not be reproduced or used without the consent of EXM

Ce dessin est confidentiel et ne doit pas être reproduit ou utilisé sans le consentement de EXM

<b>STANDARD FEATURES ARE NOT LISTED IN THIS HOLE TABLE</b>			
<b>HOLE TABLE - BOTTOM VIEW (CUSTOM FEATURE ONLY)</b>			
CUT-OUT	XDIM	YDIM	DESCRIPTION
1	2.000	1.250	LABEL_EXM

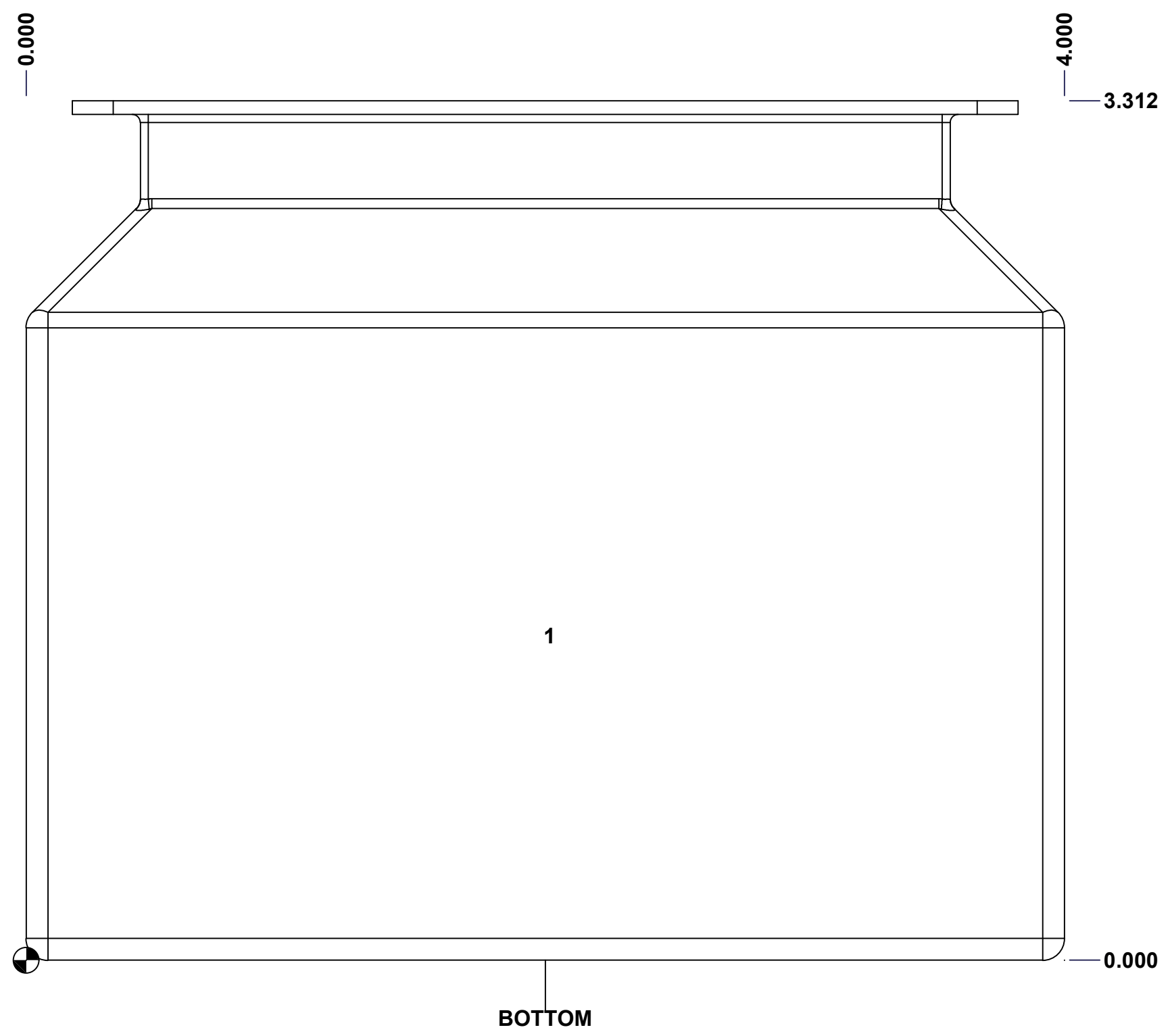

	Description	Status
	5412ESSMPCH 6" x 4" x 3" Body	(NULL)
	Part Number Numéro Pièce	Rev.
	<b>5412ESSMPCH060403NOIPB 0</b>	4
		10

This drawing is confidential and must not be reproduced or used without the consent of EXM

Ce dessin est confidentiel et ne doit pas être reproduit ou utilisé sans le consentement de EXM

<b>STANDARD FEATURES ARE NOT LISTED IN THIS HOLE TABLE</b>			
<b>HOLE TABLE - LEFT VIEW (CUSTOM FEATURE ONLY)</b>			
CUT-OUT	XDIM	YDIM	DESCRIPTION
1	1.625	0.875	STANDOFF M6 x 10mm (Inside)

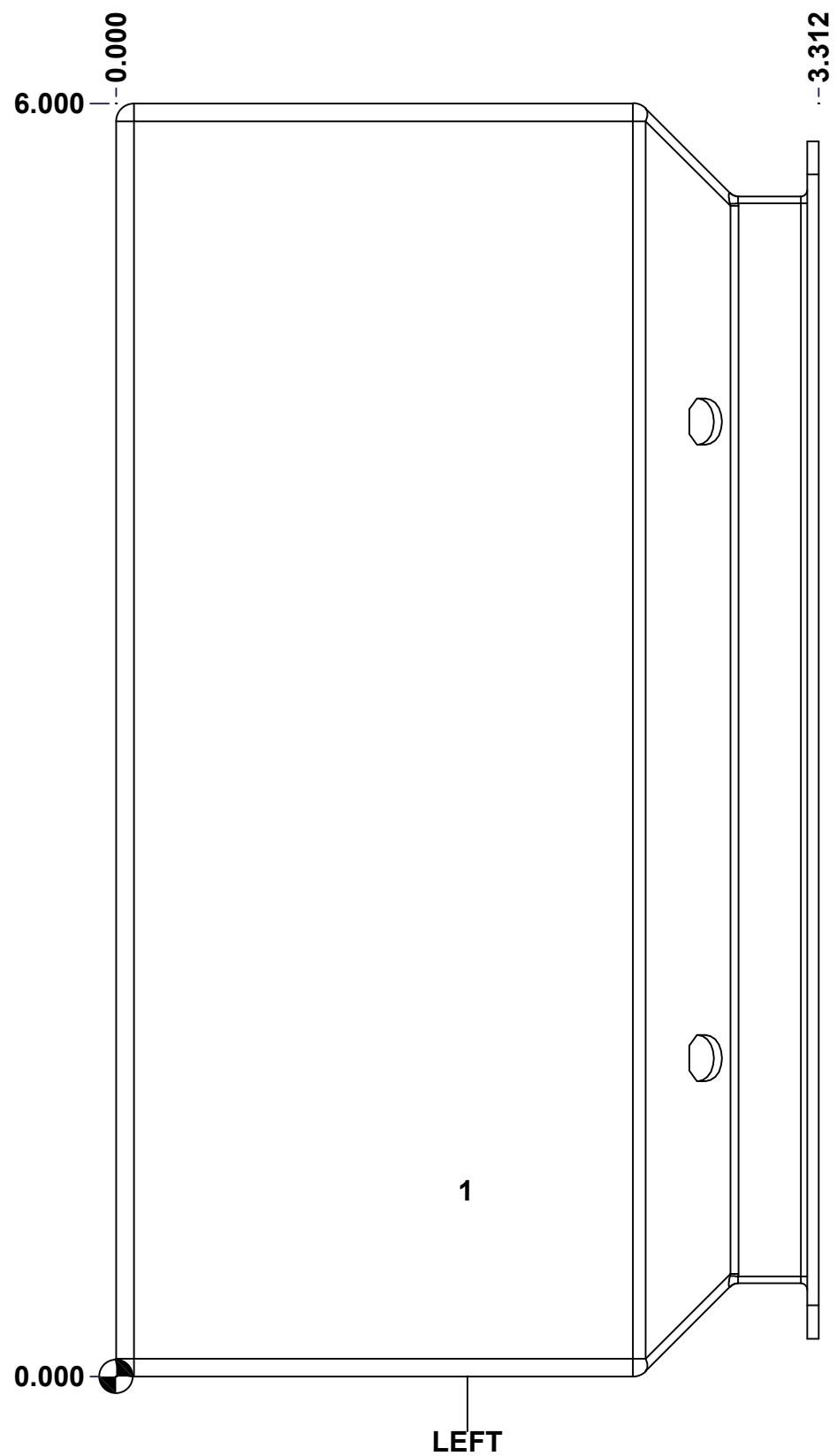

	Description	Status
	5412ESSMPCH 6" x 4" x 3" Body	(NULL)
	Part Number Numéro Pièce	Rev.
	<b>5412ESSMPCH060403NOIPB 0</b>	5
		10

This drawing is confidential and must not be reproduced or used without the consent of EXM

Ce dessin est confidentiel et ne doit pas être reproduit ou utilisé sans le consentement de EXM

**STANDARD FEATURES ARE NOT LISTED IN THIS HOLE TABLE**

**HOLE TABLE - BACK VIEW (CUSTOM FEATURE ONLY)**

CUT-OUT	XDIM	YDIM	DESCRIPTION
1	3.000	0.000	FOOT 885 ESCHMF2
2	3.000	6.000	FOOT 885 ESCHMF2
3	1.000	6.000	FOOT 885 ESCHMF2
4	1.000	0.000	FOOT 885 ESCHMF2
5	0.875	5.125	PEM FHS-M6-20 (Inside)
6	3.125	5.125	PEM FHS-M6-20 (Inside)
7	3.125	0.875	PEM FHS-M6-20 (Inside)
8	0.875	0.875	PEM FHS-M6-20 (Inside)

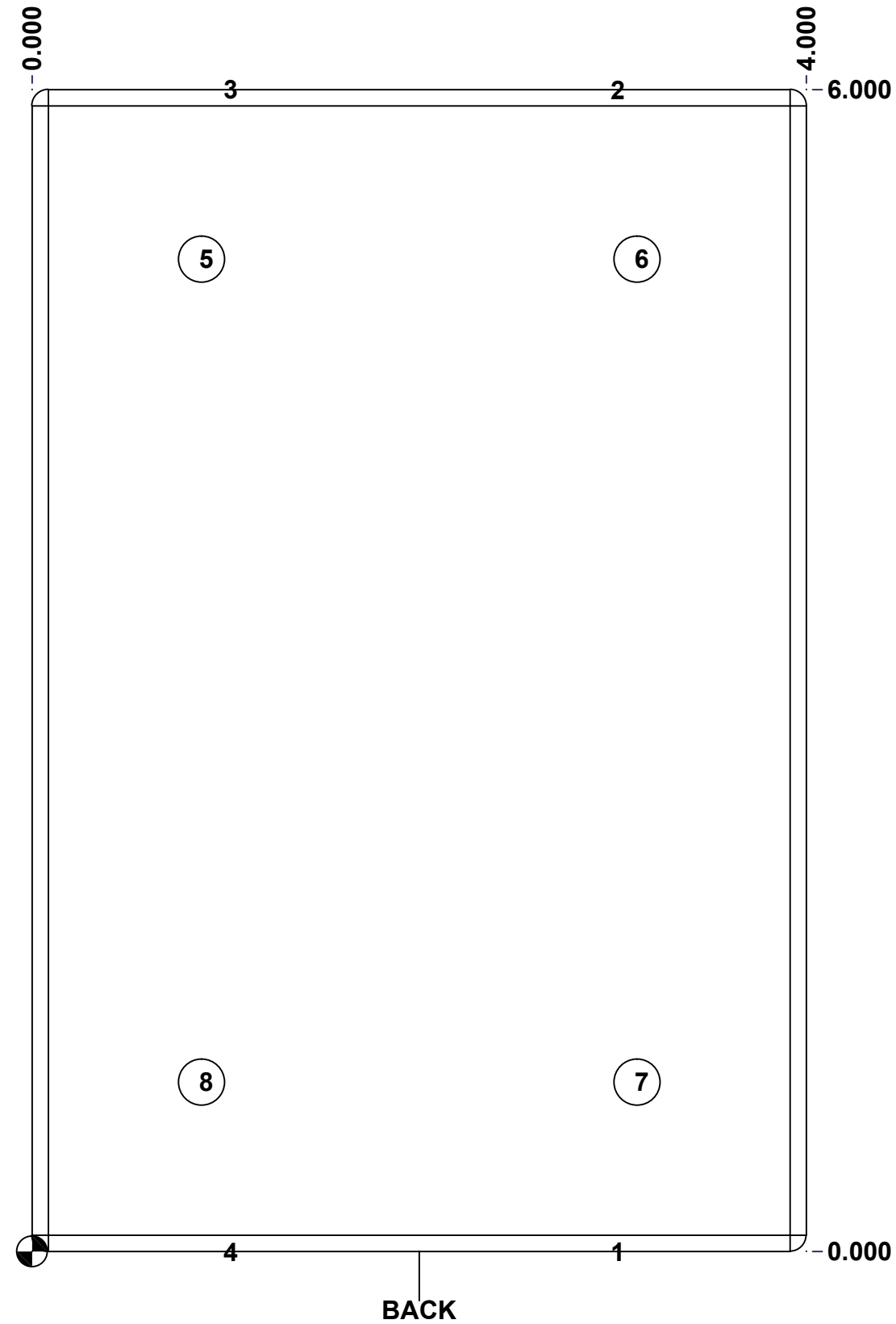

	Description	Status
	5412ESSMPCH 6" x 4" x 3" Body	(NULL)
	Part Number Numéro Pièce	Rev.
	<b>5412ESSMPCH060403NOIPB 0</b>	6
		10

This drawing is confidential and must not be reproduced or used without the consent of EXM

Ce dessin est confidentiel et ne doit pas être reproduit ou utilisé sans le consentement de EXM

No.	Revisions	Date	By/Par

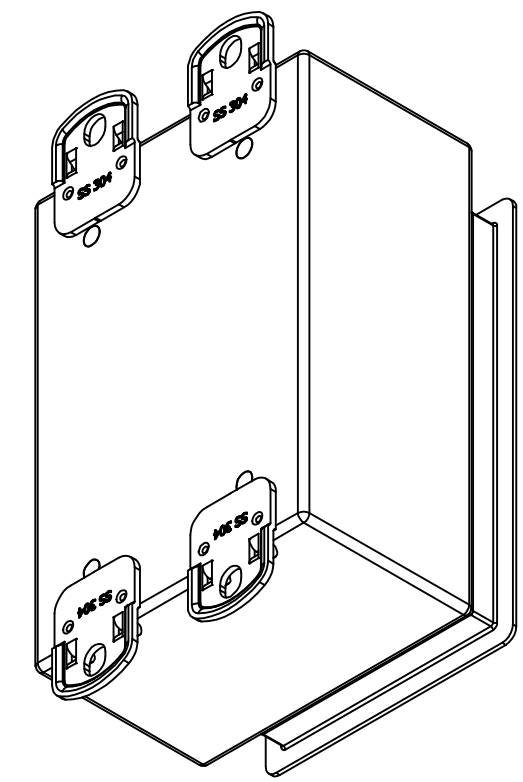

Isometric View



 Tél: (450) 979-4373  
 Fax: (450) 979-4626  
[www.exmweb.com](http://www.exmweb.com)

Flatness / Aplatissement: Max 5.0mm  
 Projection: 

Customer / Client: \_\_\_\_\_ Date: \_\_\_\_\_

Drawn By / Dessiné Par: BoxCad: BoxCad Date: 10-Mar-23

Material / Matière: 16 Ga Stainless Steel 304 (1.4mm)

Color / Couleur: Asa-61 Grey Finish / Fini: Smooth

Description: 5412ESSMPCH 6" x 4" x 3" Body

Detail Rev.:

Part Number / Numéro Pièce: **5412ESSMPCH060403NOIPB 0**

Rev. 7

Qty	Part Number	Rev	Description
4	STK-PEM-FHS-M6-20	0	SS PEM Self-Clinching Stud M6 x 20.0mm
1	STK-A-70469	6	5412 ESSMCH - Stainless Steel 316 Body Catch Assembly
1	STK-Q-08100	1	M5 Nylon Insert Lock Nut
1	STK-S-00100	0	3.5" x 2" Silver Milar Flexcon Sticker
4	STK-Q-71316	4	5412 ESSMCH Stainless Steel Mounting Foot
1	5412ESSMPCH060403NO IPB-P	0	5412ESSMPCH 6" x 4" x 3" Body Part
1	STK-Q-08500	4	Stainless Steel Standoff M6 x 10mm
1	STK-P-02400S	0	Powder Paint (Asa-61 Grey / Smooth)

Parts List

This drawing is confidential and must not be reproduced or used without the consent of EXM

Ce dessin est confidentiel et ne doit pas être reproduit ou utilisé sans le consentement de EXM

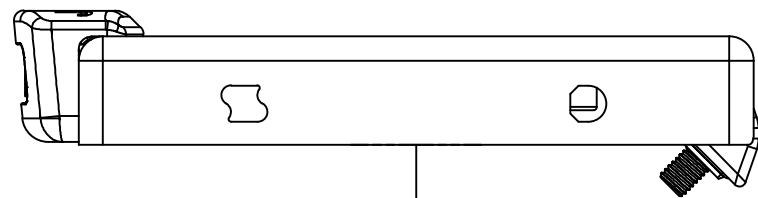

TOP

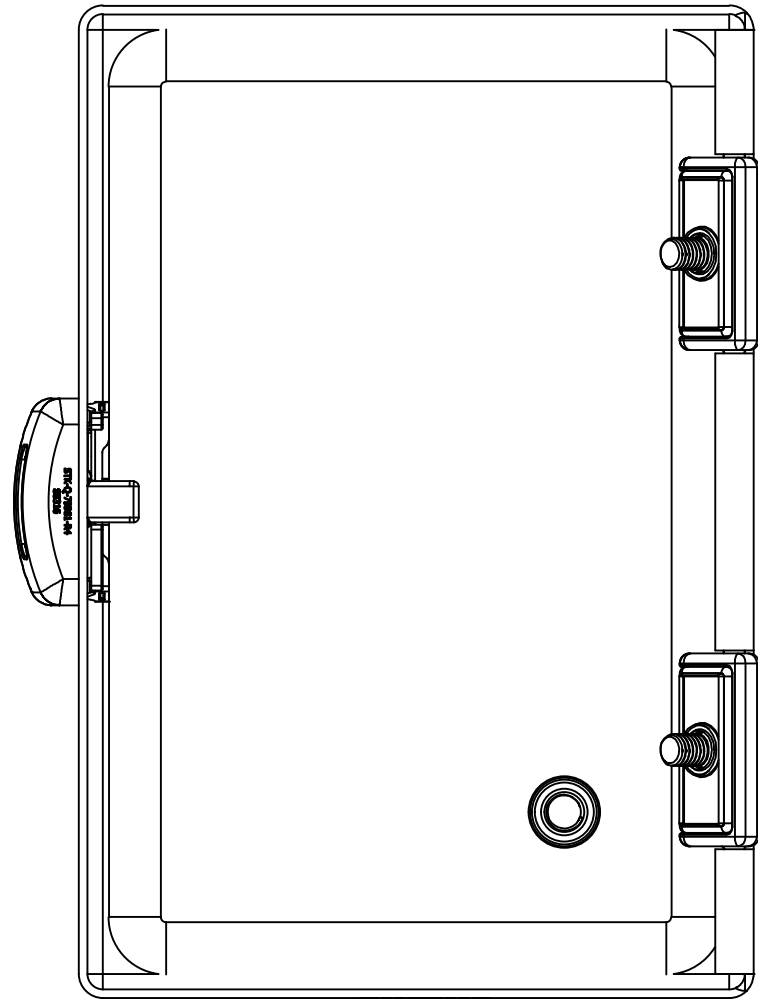

BACK

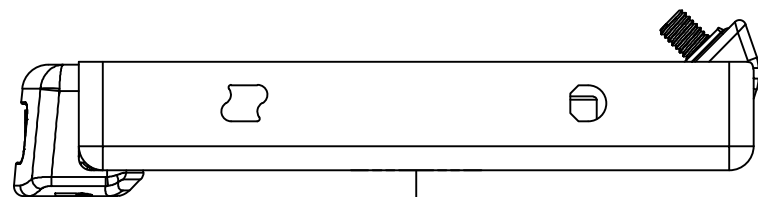

BOTTOM

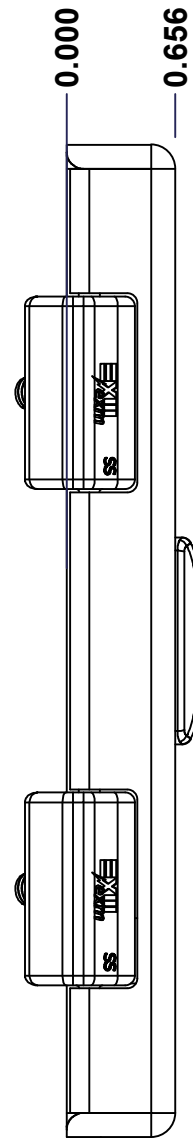

LEFT

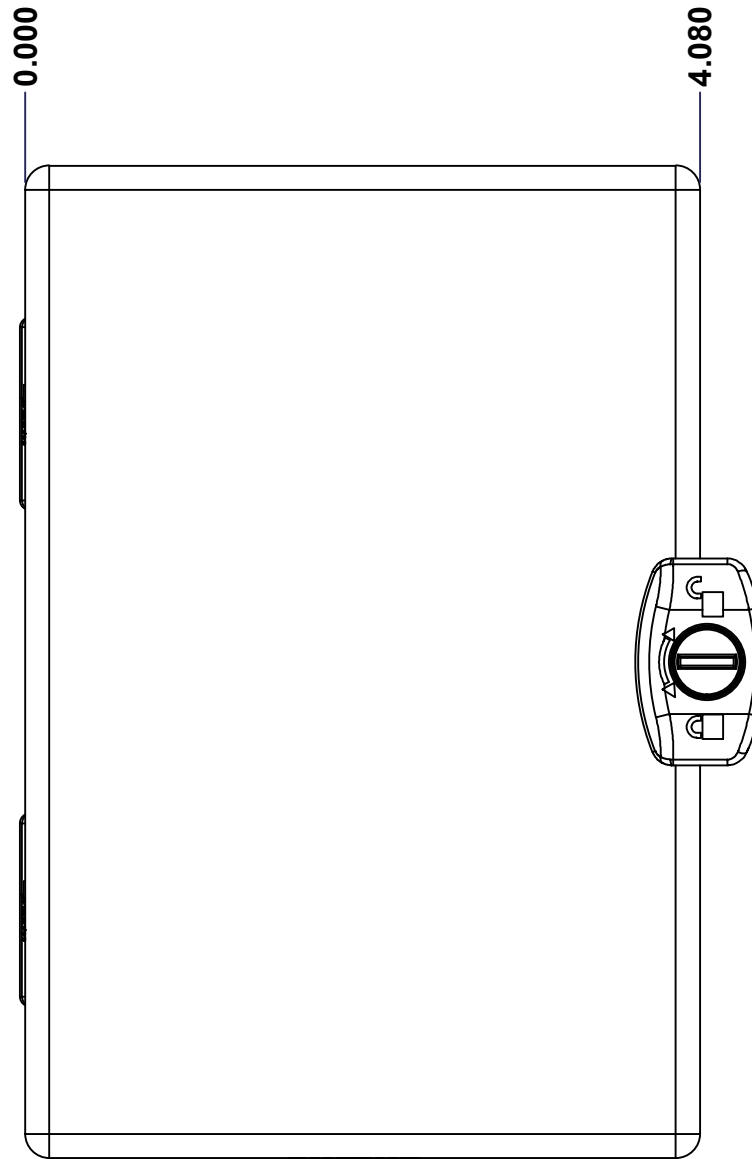

FRONT

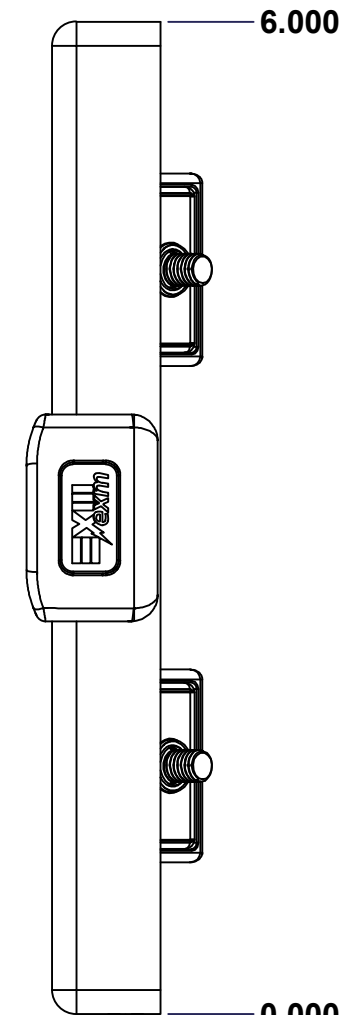

RIGHT

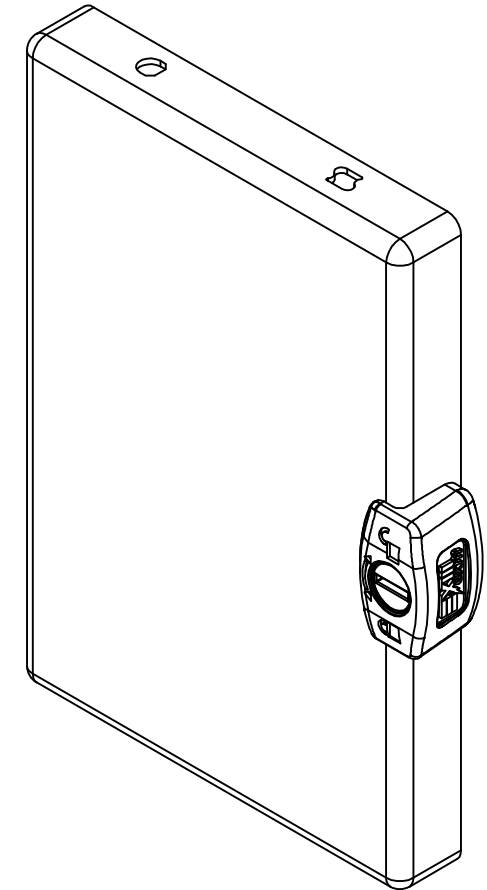

Isometric View

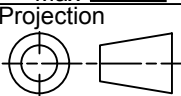

No.	Revisions	Date	By/Par

 Tél: (450) 979-4373 Fax: (450) 979-4626 <a href="http://www.exmweb.com">www.exmweb.com</a>		Flatness Aplatissement Max 5.0mm Projection 
Customer Client	Date	
Drawn By Dessiné Par	BoxCad: BoxCad	Date 10-Mar-23
Material Matière	16 Ga Stainless Steel 304 (1.4mm)	
Color Couleur	Asa-61 Grey	Finish Fini Smooth
Description	Detail Rev.	
5412ESSMPCH 6" x 4" Cover		
Part Number Numéro Pièce	Rev. 8	10

SEE BILL OF MATERIAL ON LAST PAGE 5412ESSMPCH060403NOIPC 0



This drawing is confidential and must not be reproduced or used without the consent of EXM

Ce dessin est confidentiel et ne doit pas être reproduit ou utilisé sans le consentement de EXM

STANDARD FEATURES ARE NOT LISTED IN THIS HOLE TABLE			
HOLE TABLE - FRONT VIEW (CUSTOM FEATURE ONLY)			
CUT-OUT	XDIM	YDIM	DESCRIPTION
1	1.145	1.125	STANDOFF M6 x 10mm (Inside)
2	4.080	3.000	LOCK 880 SCQ3MS @ 0.0°

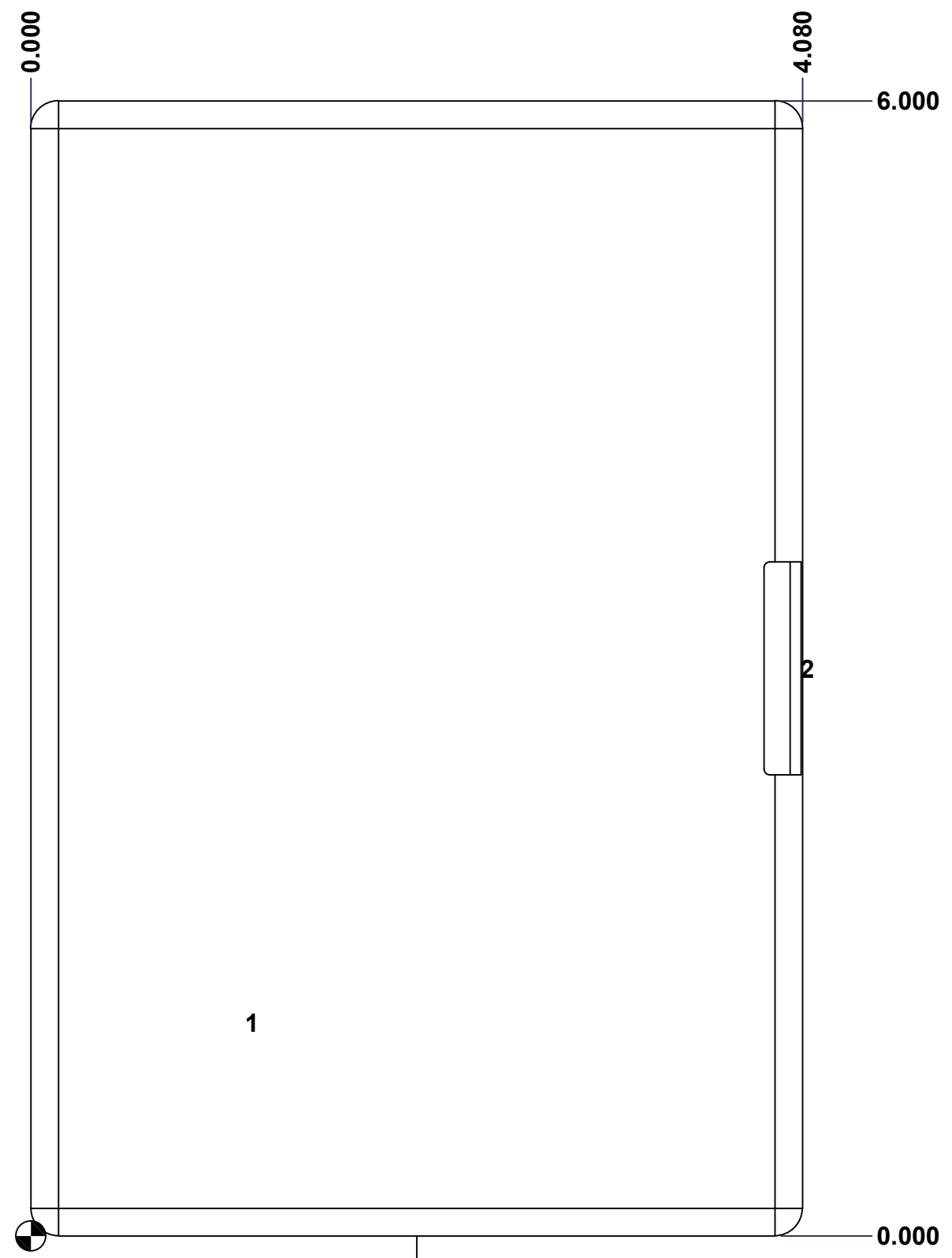

FRONT

	Description	Status
	5412ESSMPCH 6" x 4" Cover	(NULL)
	Part Number Numéro Pièce	Rev. 9
	<b>5412ESSMPCH060403NOIPC 0</b>	10

This drawing is confidential and must not be reproduced or used without the consent of EXM

Ce dessin est confidentiel et ne doit pas être reproduit ou utilisé sans le consentement de EXM

No.	Revisions	Date	By/Par

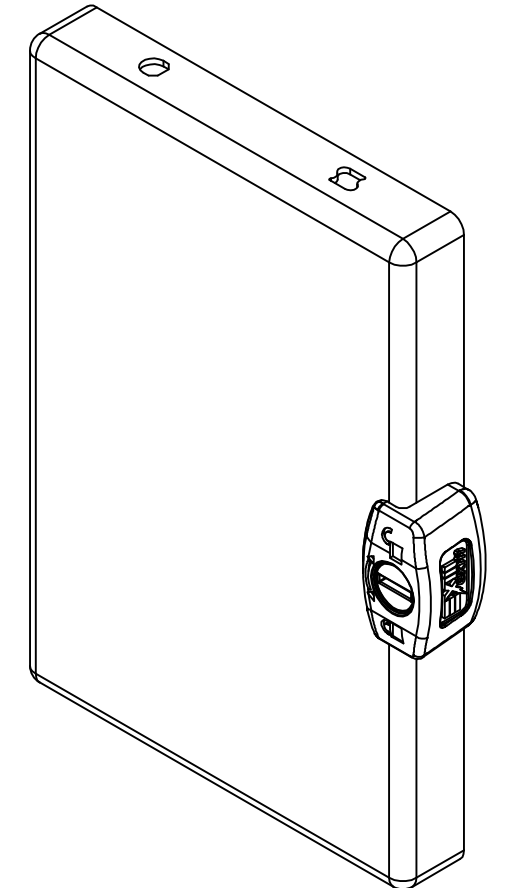

Isometric View



 Tél: (450) 979-4373  
 Fax: (450) 979-4626  
[www.exmweb.com](http://www.exmweb.com)

Flatness:  Aplatissement:   
 Max 5.0mm  
 Projection: 

Customer Client	Date
Drawn By / Dessiné Par: BoxCad: BoxCad	Date: 10-Mar-23

Material / Matière: 16 Ga Stainless Steel 304 (1.4mm)

Color / Couleur: Asa-61 Grey      Finish / Fini: Smooth

Description: 5412ESSMPCH 6" x 4" Cover      Detail Rev.

Part Number / Numéro Pièce: 5412ESSMPCH060403NOIPC 0      Rev. 10

Qty	Part Number	Rev	Description
1	5412ESSMPCH060403NO IPG	0	5412ESSMPCH 6" x 4" Gasket
1	880SCQ3S	4	5412 ESSMCH - Stainless Steel External Lock Assy - Slot Lock
1	STK-Q-08500	4	Stainless Steel Standoff M6 x 10mm
1	STK-P-02400S	0	Powder Paint (Asa-61 Grey / Smooth)
1	5412ESSMPCH060403NO IPC-P	0	5412ESSMPCH 6" x 4" Cover Part
2	STK-A-33038	3	5412 ESSMCH - Stainless Steel Hinge
Parts List			

**5412ESSMPCH060403NOIPC 0**