

This drawing is confidential and must not be reproduced or used without the consent of EXM

Ce dessin est confidentiel et ne doit pas être reproduit ou utilisé sans le consentement de EXM

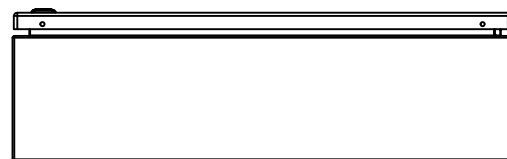

TOP

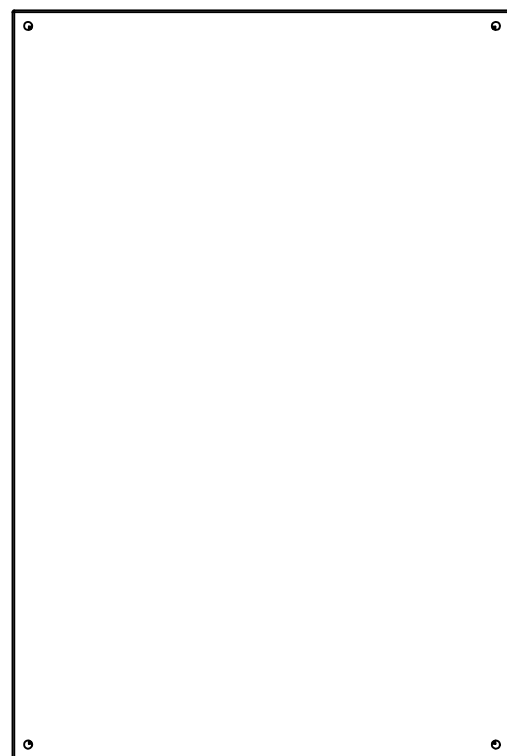

BACK

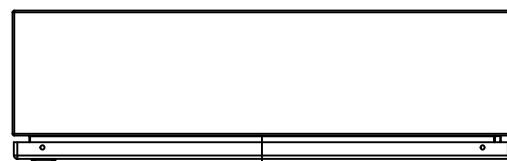

BOTTOM

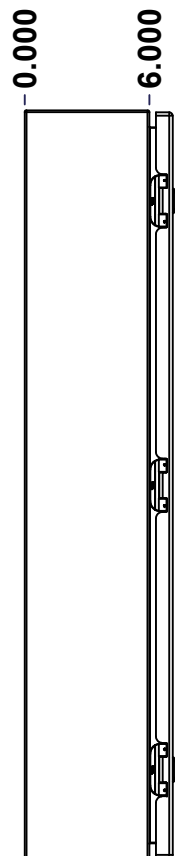

LEFT

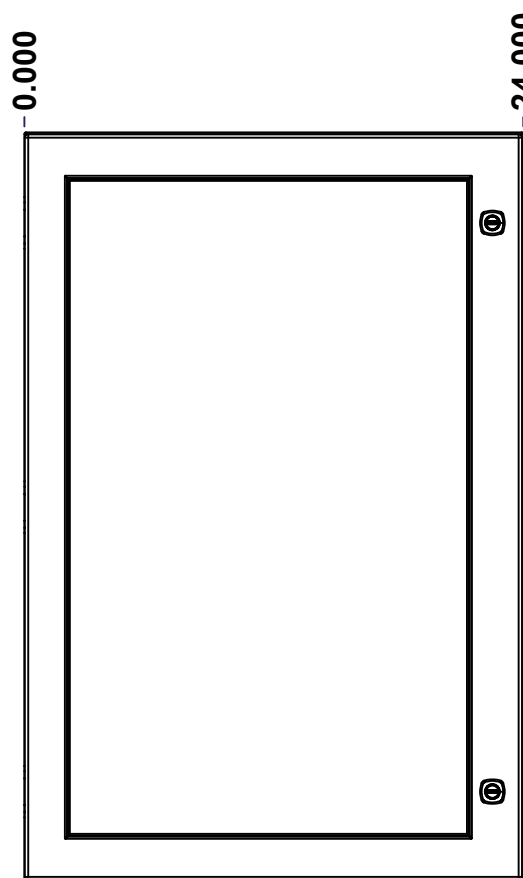

FRONT

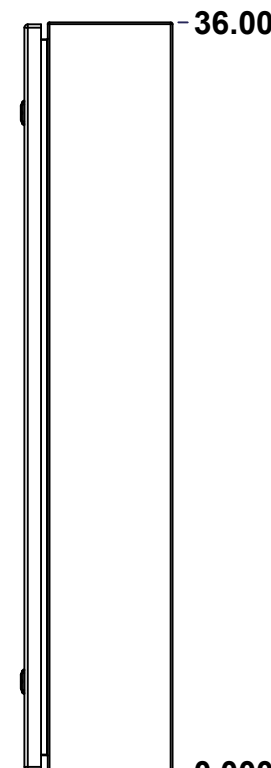

RIGHT

| No. | Revisions | Date | By/Par |
|-----|-----------|------|--------|
|     |           |      |        |
|     |           |      |        |
|     |           |      |        |
|     |           |      |        |
|     |           |      |        |

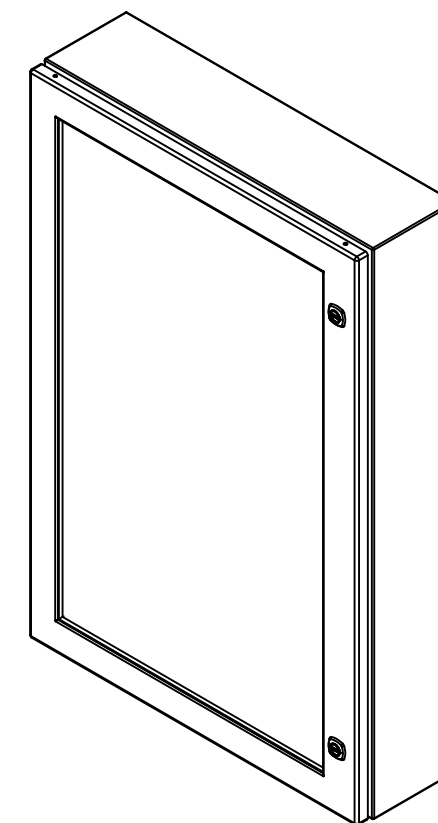

Isometric View



Tél: (450) 979-4373  
 Fax: (450) 979-4626  
[www.exmweb.com](http://www.exmweb.com)

Flatness  
Aplatissement

Max 3.0mm

Projection

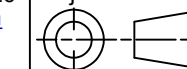

|                                        |                 |
|----------------------------------------|-----------------|
| Customer Client                        | Date            |
| Drawn By / Dessiné Par: BoxCad: BoxCad | Date: 03-Sep-13 |

Material / Matière: 16 Ga H.R.P. & O. (1.4mm)

Color / Couleur: Asa-61 Grey      Finish / Fini: Smooth

Description: 5412ESW 36" x 24" x 6" Assembly      Detail Rev.

|                                           |        |   |   |
|-------------------------------------------|--------|---|---|
| Part Number / Numéro Pièce: 5412ESW362406 | Rev. 0 | 1 | 2 |
|-------------------------------------------|--------|---|---|

SEE BILL OF MATERIAL ON LAST PAGE

This drawing is confidential and must not be reproduced or used without the consent of EXM

Ce dessin est confidentiel et ne doit pas être reproduit ou utilisé sans le consentement de EXM

| NOTE |                                            |
|------|--------------------------------------------|
| ITEM | DESCRIPTION                                |
| 1    | NEMA 4/12 Enclosure                        |
| 2    | C/W Standard ground studs on box and cover |
| 3    | W/O Standard door stiffener                |
| 4    | C/W Standard inner panel (Included)        |
| 5    | C/W Standard inner panel mounting studs    |

| No. | Revisions | Date | By/Par |
|-----|-----------|------|--------|
|     |           |      |        |
|     |           |      |        |
|     |           |      |        |
|     |           |      |        |
|     |           |      |        |
|     |           |      |        |

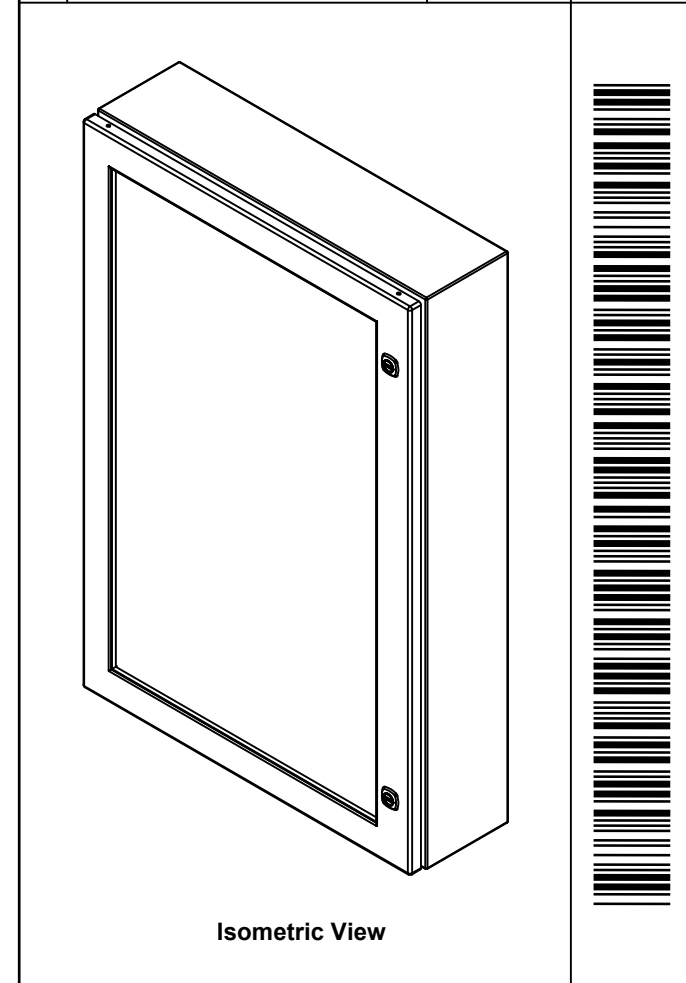

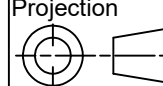
|                                                                                                                                                                                        |                           |                                                                                                                                               |
|----------------------------------------------------------------------------------------------------------------------------------------------------------------------------------------|---------------------------|-----------------------------------------------------------------------------------------------------------------------------------------------|
|  Tél: (450) 979-4373<br>Fax: (450) 979-4626<br><a href="http://www.exmweb.com">www.exmweb.com</a> |                           | Flatness<br>Aplatissement<br>Max 3.0mm<br>Projection<br> |
| Customer<br>Client                                                                                                                                                                     | Date                      |                                                                                                                                               |
| Drawn By<br>Dessiné Par                                                                                                                                                                | BoxCad: BoxCad            | Date 03-Sep-13                                                                                                                                |
| Material<br>Matière                                                                                                                                                                    | 16 Ga H.R.P. & O. (1.4mm) |                                                                                                                                               |
| Color<br>Couleur                                                                                                                                                                       | Asa-61 Grey               | Finish<br>Fini Smooth                                                                                                                         |
| Description                                                                                                                                                                            |                           | Detail Rev.                                                                                                                                   |
| 5412ESW 36" x 24" x 6" Assembly                                                                                                                                                        |                           |                                                                                                                                               |
| Part Number<br>Numéro Pièce                                                                                                                                                            | <b>5412ESW362406</b>      | Rev. 2                                                                                                                                        |
|                                                                                                                                                                                        |                           | <b>0</b>                                                                                                                                      |

| Qty        | Part Number    | Rev | Description                                            |
|------------|----------------|-----|--------------------------------------------------------|
| 1          | 880 PP         | 6   | Self Adhesive Print Pocket                             |
| 1          | STK-K-01800    | 5   | 5412 ES Accessory Kit                                  |
| 1          | 881 SP3624G    | 0   | 881 SP - Inner Panel                                   |
| 1          | 5412ESW362406C | 0   | 5412ESW 36" x 24" Cover                                |
| 6          | STK-Q-07310    | 2   | Flange Lock Nut M8                                     |
| 6          | STK-Q-07610    | 8   | M8 Plastic Spacer 22.2mm                               |
| 1          | 5412ESW362406B | 0   | 5412ESW 36" x 24" x 6" Body                            |
| 3          | STK-Q-04050-07 | 7   | M6 x 7mm Hexagon Socket Head Machine Screw with Nyseal |
| Parts List |                |     |                                                        |

| PACKING               |     |                                            |
|-----------------------|-----|--------------------------------------------|
| ITEM                  | QTY | DESCRIPTION                                |
| Cardboard sleeve      | 2   | Top and Bottom                             |
| Cardboard strip       | 2   | Between back of enclosure and inner panel  |
| Plastic bag           | 1   | To protect cover surface and inside gasket |
| Plastic strap - Black | 2   | To Squeeze the 2 cardboard sleeve together |
| Packaging label       | 1   | White label with product number            |

This drawing is confidential and must not be reproduced or used without the consent of EXM

Ce dessin est confidentiel et ne doit pas être reproduit ou utilisé sans le consentement de EXM

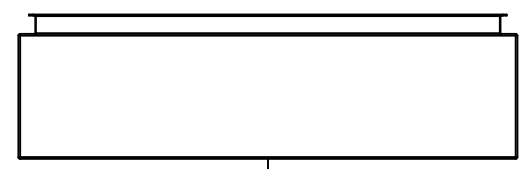

TOP

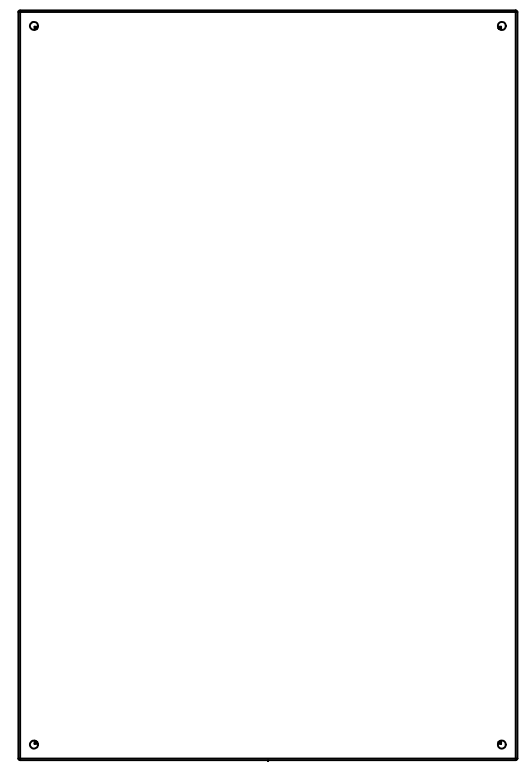

BACK

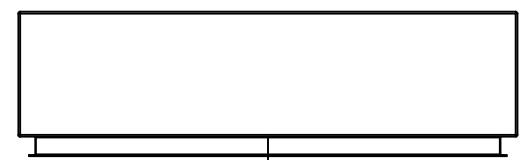

BOTTOM

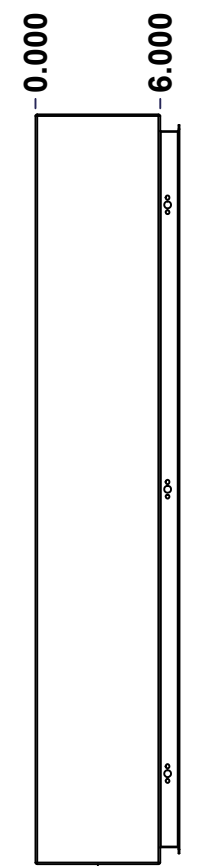

LEFT

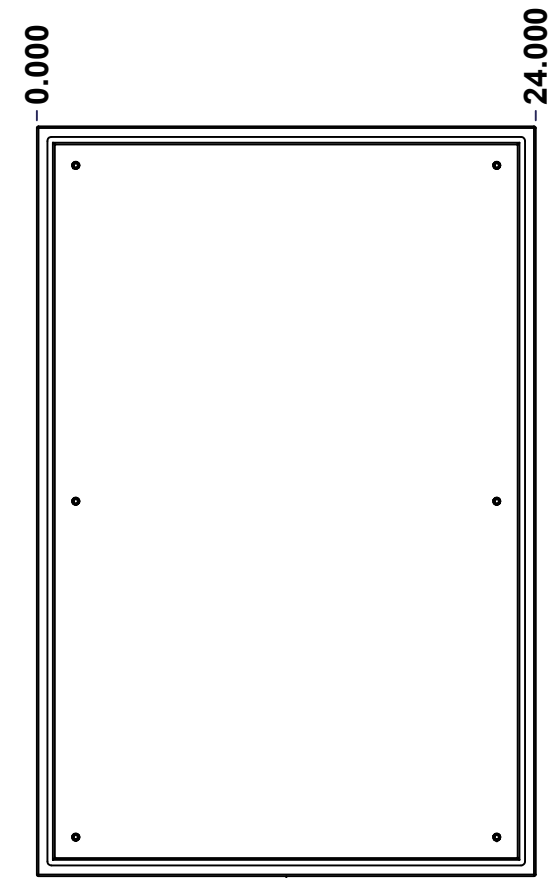

FRONT



RIGHT

| No. | Revisions | Date | By/Par |
|-----|-----------|------|--------|
|     |           |      |        |
|     |           |      |        |
|     |           |      |        |
|     |           |      |        |

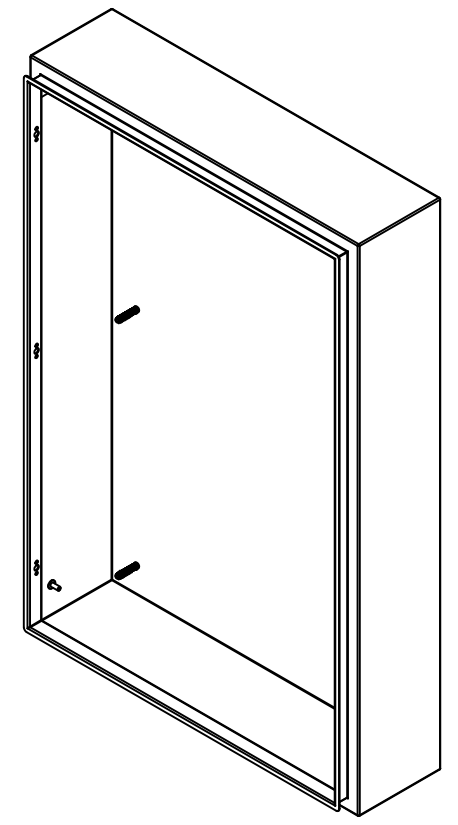

Isometric View

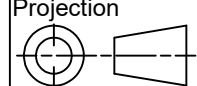

|                                                                                                                                                                                        |                              |                                                                                                                                               |
|----------------------------------------------------------------------------------------------------------------------------------------------------------------------------------------|------------------------------|-----------------------------------------------------------------------------------------------------------------------------------------------|
|  Tél: (450) 979-4373<br>Fax: (450) 979-4626<br><a href="http://www.exmweb.com">www.exmweb.com</a> |                              | Flatness<br>Aplatissement<br>Max 3.0mm<br>Projection<br> |
| Customer Client                                                                                                                                                                        | Date                         |                                                                                                                                               |
| Drawn By / Dessiné Par: BoxCad: BoxCad                                                                                                                                                 | Date: 03-Sep-13              |                                                                                                                                               |
| Material / Matière: 16 Ga H.R.P. & O. (1.4mm)                                                                                                                                          | Color / Couleur: Asa-61 Grey |                                                                                                                                               |
|                                                                                                                                                                                        | Finish / Fini: Smooth        |                                                                                                                                               |
| Description: 5412ESW 36" x 24" x 6" Body                                                                                                                                               |                              | Detail Rev.                                                                                                                                   |
| Part Number / Numéro Pièce: 5412ESW362406B                                                                                                                                             | Rev. 0                       | 1 / 7                                                                                                                                         |

SEE BILL OF MATERIAL ON LAST PAGE

This drawing is confidential and must not be reproduced or used without the consent of EXM

Ce dessin est confidentiel et ne doit pas être reproduit ou utilisé sans le consentement de EXM

| STANDARD FEATURES ARE NOT LISTED IN THIS HOLE TABLE |       |        |                             |
|-----------------------------------------------------|-------|--------|-----------------------------|
| HOLE TABLE - LEFT VIEW (CUSTOM FEATURE ONLY)        |       |        |                             |
| CUT-OUT                                             | XDIM  | YDIM   | DESCRIPTION                 |
| 1                                                   | 4.500 | 2.000  | GND STUD M6 x 16mm (Inside) |
| 2                                                   | 4.000 | 34.000 | LABEL_EXM (Inside)          |

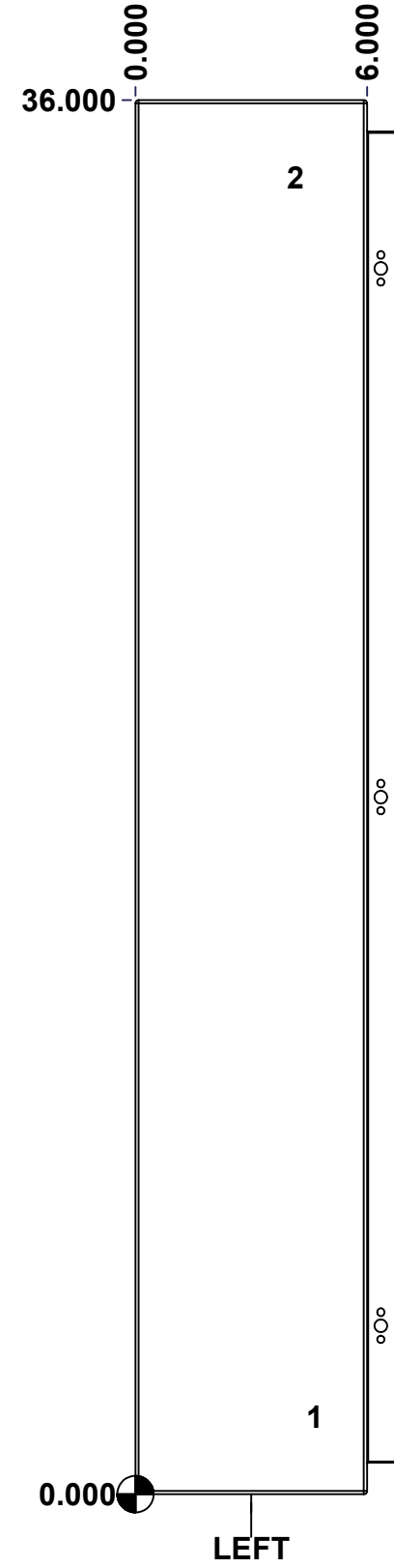

|  |                             |          |       |
|--|-----------------------------|----------|-------|
|  | Description                 | Status   |       |
|  | 5412ESW 36" x 24" x 6" Body |          |       |
|  | Part Number<br>Numéro Pièce | Rev.     |       |
|  | <b>5412ESW362406B</b>       | <b>0</b> | 5 / 7 |

This drawing is confidential and must not be reproduced or used without the consent of EXM

Ce dessin est confidentiel et ne doit pas être reproduit ou utilisé sans le consentement de EXM

**STANDARD FEATURES ARE NOT LISTED IN THIS HOLE TABLE**

**HOLE TABLE - BACK VIEW (CUSTOM FEATURE ONLY)**

| CUT-OUT | XDIM   | YDIM   | DESCRIPTION                |
|---------|--------|--------|----------------------------|
| 1       | 1.875  | 1.875  | IP STUD M8 x 35mm (Inside) |
| 2       | 1.875  | 34.125 | IP STUD M8 x 35mm (Inside) |
| 3       | 22.125 | 34.125 | IP STUD M8 x 35mm (Inside) |
| 4       | 22.125 | 1.875  | IP STUD M8 x 35mm (Inside) |
| 5       | 1.875  | 18.000 | IP STUD M8 x 35mm (Inside) |
| 6       | 22.125 | 18.000 | IP STUD M8 x 35mm (Inside) |
| -----   |        |        |                            |
| 7       | 23.250 | 0.750  | RND Ø0.390                 |
| 8       | 23.250 | 35.250 | RND Ø0.390                 |
| 9       | 0.750  | 35.250 | RND Ø0.390                 |
| 10      | 0.750  | 0.750  | RND Ø0.390                 |

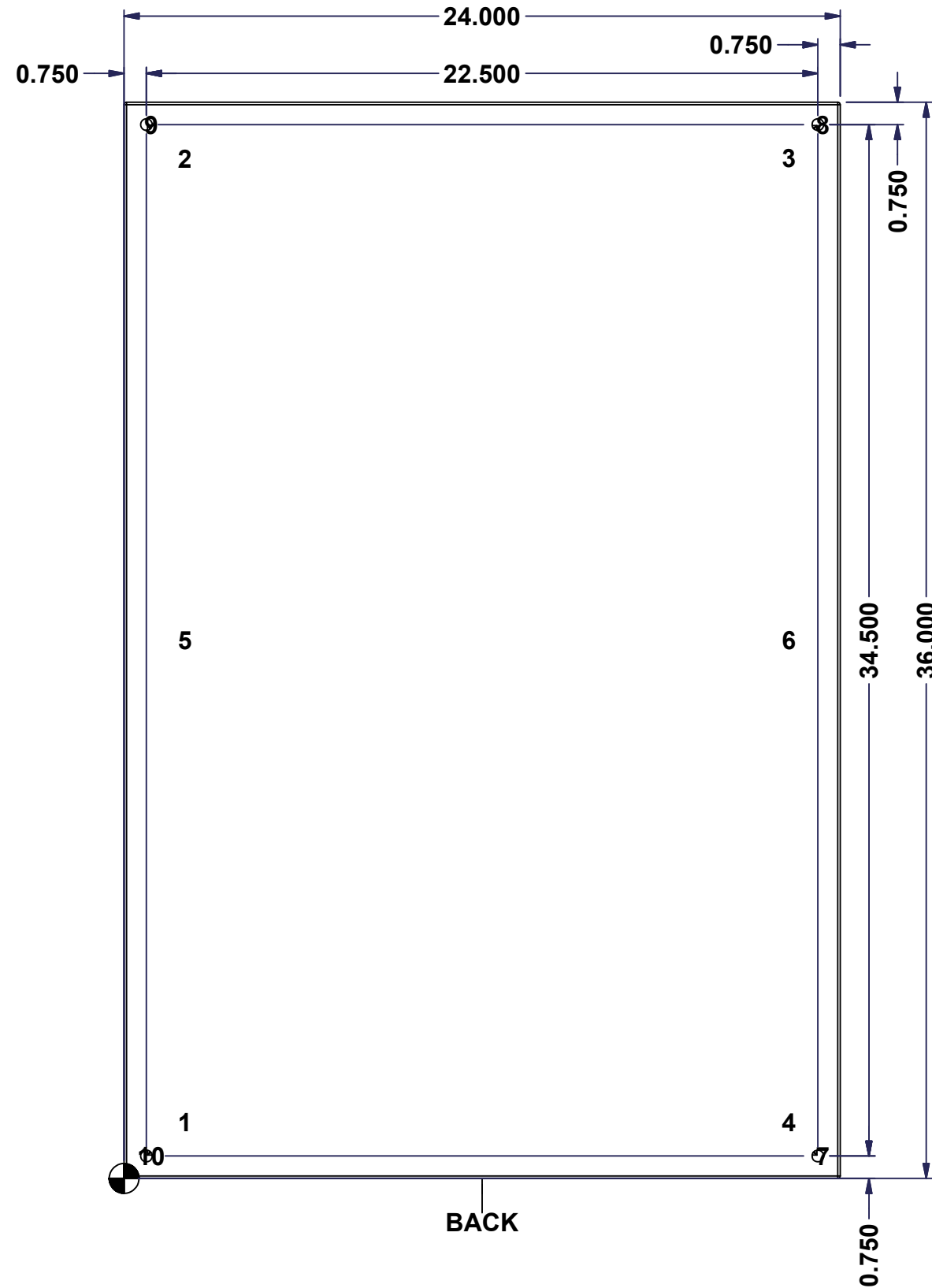

|  |                             |          |   |
|--|-----------------------------|----------|---|
|  | Description                 | Status   |   |
|  | 5412ESW 36" x 24" x 6" Body |          |   |
|  | Part Number                 | Rev.     | 6 |
|  | Numéro Pièce                | <b>0</b> | 7 |
|  | <b>5412ESW362406B</b>       |          |   |

This drawing is confidential and must not be reproduced or used without the consent of EXM

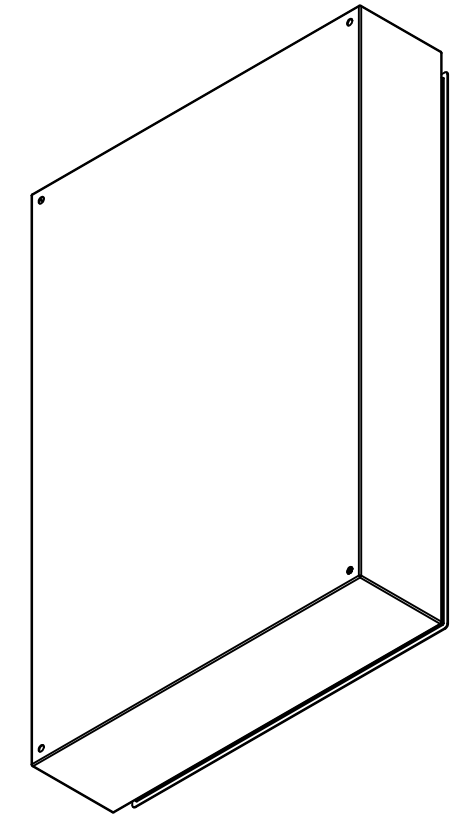

Ce dessin est confidentiel et ne doit pas être reproduit ou utilisé sans le consentement de EXM

| No. | Revisions | Date | By/Par |
|-----|-----------|------|--------|
|     |           |      |        |
|     |           |      |        |
|     |           |      |        |
|     |           |      |        |
|     |           |      |        |



Isometric View

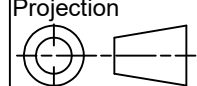

|                                                                                                                                                                                        |                           |                                                                                                                                                                                                                                        |
|----------------------------------------------------------------------------------------------------------------------------------------------------------------------------------------|---------------------------|----------------------------------------------------------------------------------------------------------------------------------------------------------------------------------------------------------------------------------------|
|  Tél: (450) 979-4373<br>Fax: (450) 979-4626<br><a href="http://www.exmweb.com">www.exmweb.com</a> |                           | Flatness<br>Aplatissement<br><br>Max 3.0mm<br>Projection<br> |
| Customer<br>Client                                                                                                                                                                     | Date                      |                                                                                                                                                                                                                                        |
| Drawn By<br>Dessiné Par                                                                                                                                                                | BoxCad: BoxCad            | Date 03-Sep-13                                                                                                                                                                                                                         |
| Material<br>Matière                                                                                                                                                                    | 16 Ga H.R.P. & O. (1.4mm) |                                                                                                                                                                                                                                        |
| Color<br>Couleur                                                                                                                                                                       | Asa-61 Grey               | Finish<br>Fini Smooth                                                                                                                                                                                                                  |
| Description                                                                                                                                                                            | Detail Rev.               |                                                                                                                                                                                                                                        |
| 5412ESW 36" x 24" x 6" Body                                                                                                                                                            |                           |                                                                                                                                                                                                                                        |
| Part Number<br>Numéro Pièce                                                                                                                                                            | Rev.                      | 7                                                                                                                                                                                                                                      |
| <b>5412ESW362406B</b>                                                                                                                                                                  | <b>0</b>                  | 7                                                                                                                                                                                                                                      |

| Qty        | Part Number      | Rev | Description                            |
|------------|------------------|-----|----------------------------------------|
| 1          | STK-S-00100      | 0   | 3.5" x 2" Silver Milar Flexcon Sticker |
| 1          | STK-Q-16080      | 0   | Ground Stud M6 x 16mm                  |
| 1          | STK-P-02400S     | 0   | Powder Paint (Asa-61 Grey / Smooth)    |
| 6          | STK-Q-16005      | 1   | Stud M8 x 35 (No Paint Cap Required)   |
| 1          | 5412ESW362406B-P | 0   | 5412ESW 36" x 24" x 6" Body Part       |
| Parts List |                  |     |                                        |

This drawing is confidential and must not be reproduced or used without the consent of EXM

Ce dessin est confidentiel et ne doit pas être reproduit ou utilisé sans le consentement de EXM

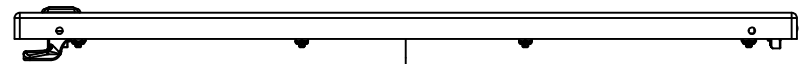

TOP

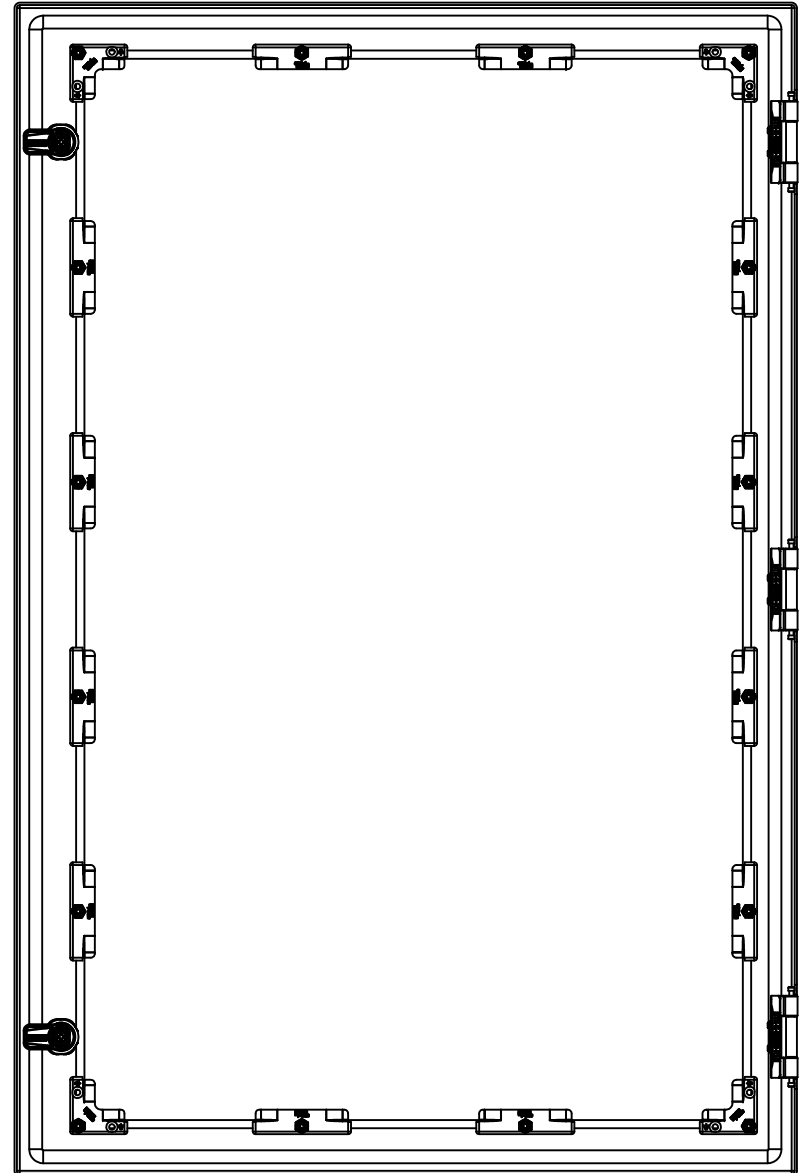

BACK

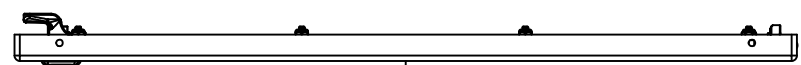

BOTTOM

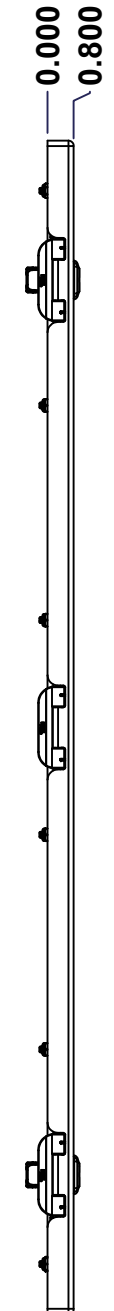

LEFT

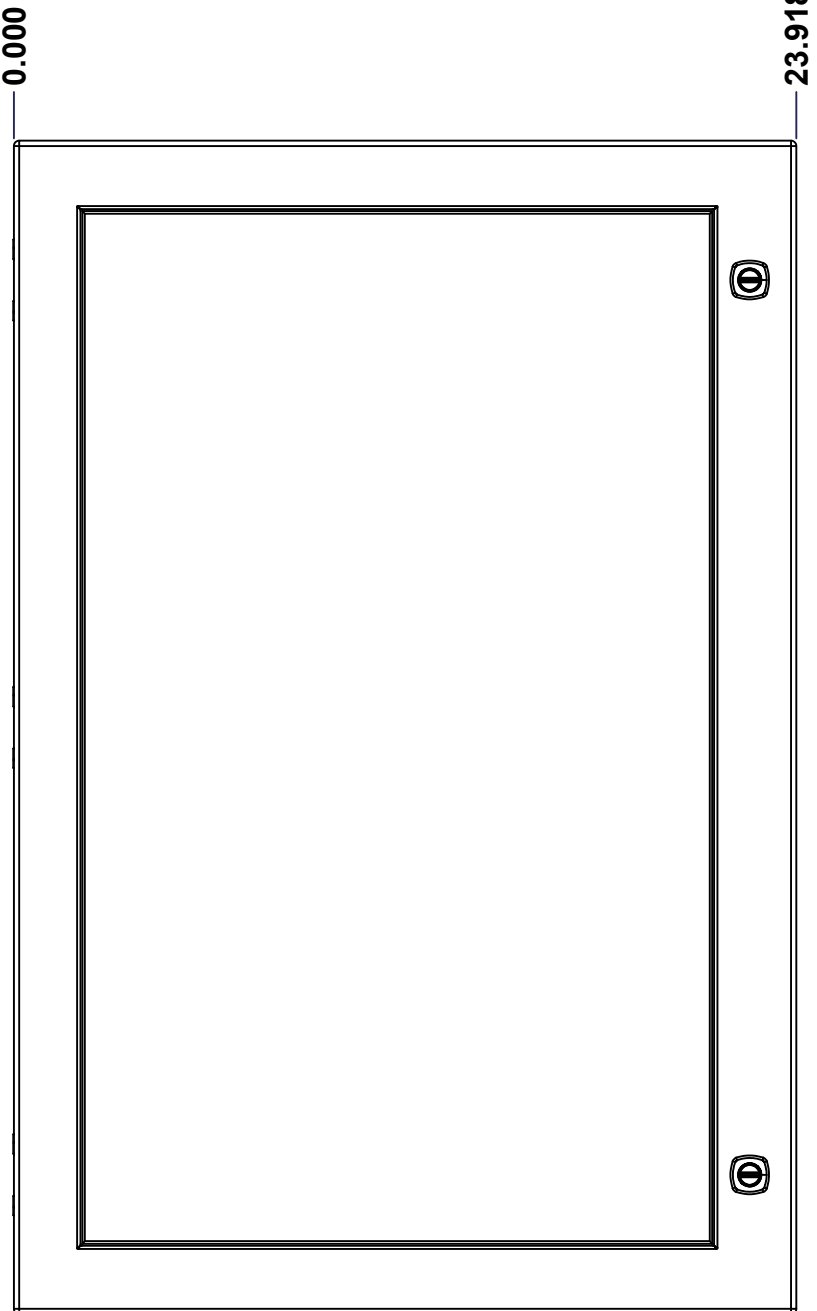

FRONT

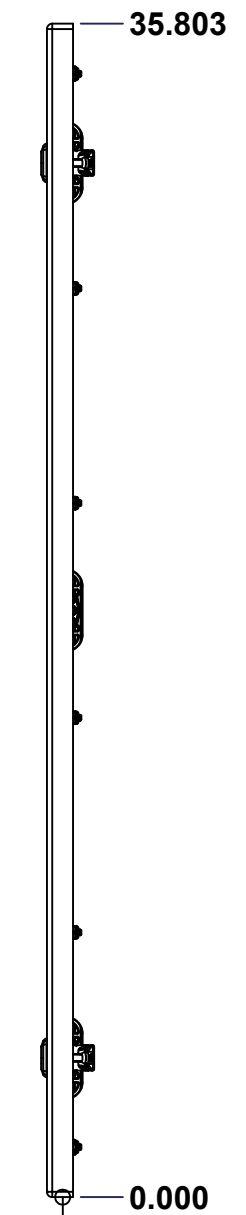

RIGHT

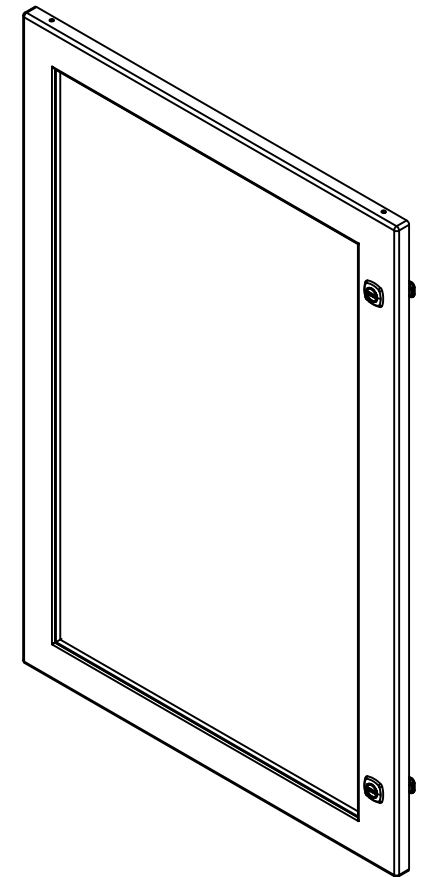

Isometric View

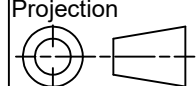

| No. | Revisions | Date | By/Par |
|-----|-----------|------|--------|
|     |           |      |        |
|     |           |      |        |
|     |           |      |        |
|     |           |      |        |
|     |           |      |        |

|                                                                                                                                                                                        |                           |                                                                                                                                               |
|----------------------------------------------------------------------------------------------------------------------------------------------------------------------------------------|---------------------------|-----------------------------------------------------------------------------------------------------------------------------------------------|
|  Tél: (450) 979-4373<br>Fax: (450) 979-4626<br><a href="http://www.exmweb.com">www.exmweb.com</a> |                           | Flatness<br>Aplatissement<br>Max 3.0mm<br>Projection<br> |
| Customer Client                                                                                                                                                                        | Date                      |                                                                                                                                               |
| Drawn By<br>Dessiné Par                                                                                                                                                                | BoxCad: BoxCad            | Date 03-Sep-13                                                                                                                                |
| Material<br>Matière                                                                                                                                                                    | 14 Ga H.R.P. & O. (1.7mm) |                                                                                                                                               |
| Color<br>Couleur                                                                                                                                                                       | Asa-61 Grey               | Finish<br>Fini Smooth                                                                                                                         |
| Description                                                                                                                                                                            | Detail Rev.               |                                                                                                                                               |
| 5412ESW 36" x 24" Cover                                                                                                                                                                |                           |                                                                                                                                               |
| Part Number<br>Numéro Pièce                                                                                                                                                            | Rev. 0                    | 1<br>3                                                                                                                                        |
| <b>5412ESW362406C</b>                                                                                                                                                                  |                           |                                                                                                                                               |

SEE BILL OF MATERIAL ON LAST PAGE

This drawing is confidential and must not be reproduced or used without the consent of EXM

Ce dessin est confidentiel et ne doit pas être reproduit ou utilisé sans le consentement de EXM

**STANDARD FEATURES ARE NOT LISTED IN THIS HOLE TABLE**

**HOLE TABLE - FRONT VIEW (CUSTOM FEATURE ONLY)**

| CUT-OUT | XDIM   | YDIM   | DESCRIPTION             |
|---------|--------|--------|-------------------------|
| 1       | 1.469  | 8.077  | STUD M6 x 18mm (Inside) |
| 2       | 21.968 | 8.077  | STUD M6 x 18mm (Inside) |
| 3       | 1.469  | 14.627 | STUD M6 x 18mm (Inside) |
| 4       | 21.968 | 14.627 | STUD M6 x 18mm (Inside) |
| 5       | 1.469  | 21.176 | STUD M6 x 18mm (Inside) |
| 6       | 21.968 | 21.176 | STUD M6 x 18mm (Inside) |
| 7       | 1.469  | 27.726 | STUD M6 x 18mm (Inside) |
| 8       | 21.968 | 27.726 | STUD M6 x 18mm (Inside) |
| 9       | 1.469  | 34.276 | STUD M6 x 18mm (Inside) |
| 10      | 1.469  | 1.527  | STUD M6 x 18mm (Inside) |
| 11      | 8.302  | 34.276 | STUD M6 x 18mm (Inside) |
| 12      | 8.302  | 1.527  | STUD M6 x 18mm (Inside) |
| 13      | 15.135 | 34.276 | STUD M6 x 18mm (Inside) |
| 14      | 15.135 | 1.527  | STUD M6 x 18mm (Inside) |
| 15      | 21.968 | 34.276 | STUD M6 x 18mm (Inside) |
| 16      | 21.968 | 1.527  | STUD M6 x 18mm (Inside) |
| -----   |        |        |                         |
| 17      | 22.494 | 31.553 | LOCK 880 SCQ4-SL @ 0.0° |
| 18      | 22.494 | 4.250  | LOCK 880 SCQ4-SL @ 0.0° |

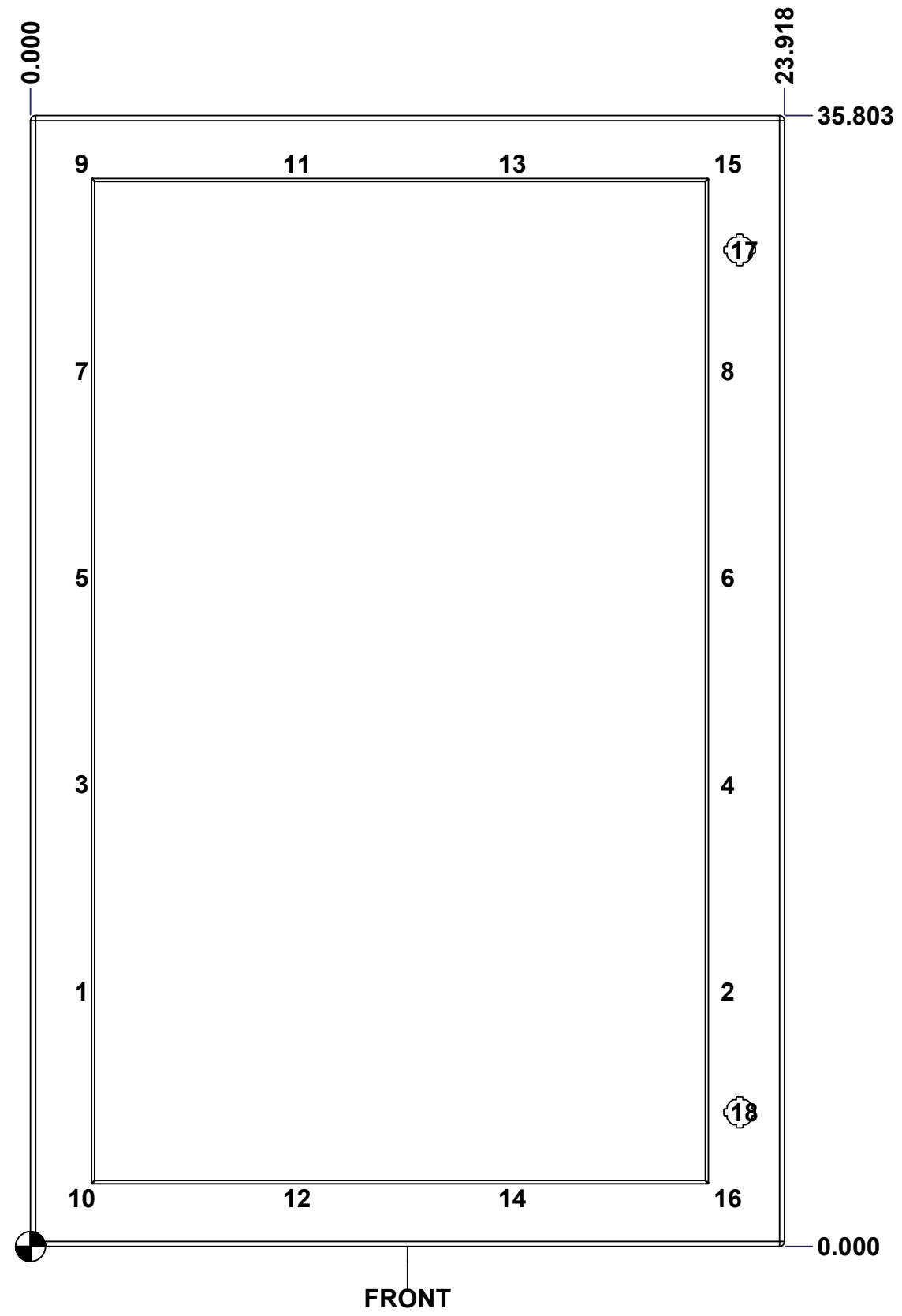

|  |                             |          |        |
|--|-----------------------------|----------|--------|
|  | Description                 | Status   |        |
|  | 5412ESW 36" x 24" Cover     | (NULL)   |        |
|  | Part Number<br>Numéro Pièce | Rev.     |        |
|  | <b>5412ESW362406C</b>       | <b>0</b> | 2<br>3 |





This drawing is confidential and must not be reproduced or used without the consent of EXM

Ce dessin est confidentiel et ne doit pas être reproduit ou utilisé sans le consentement de EXM

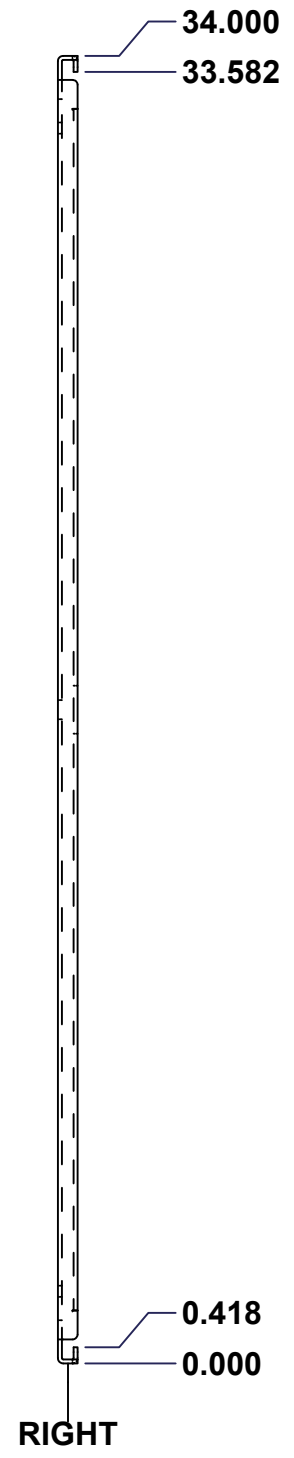
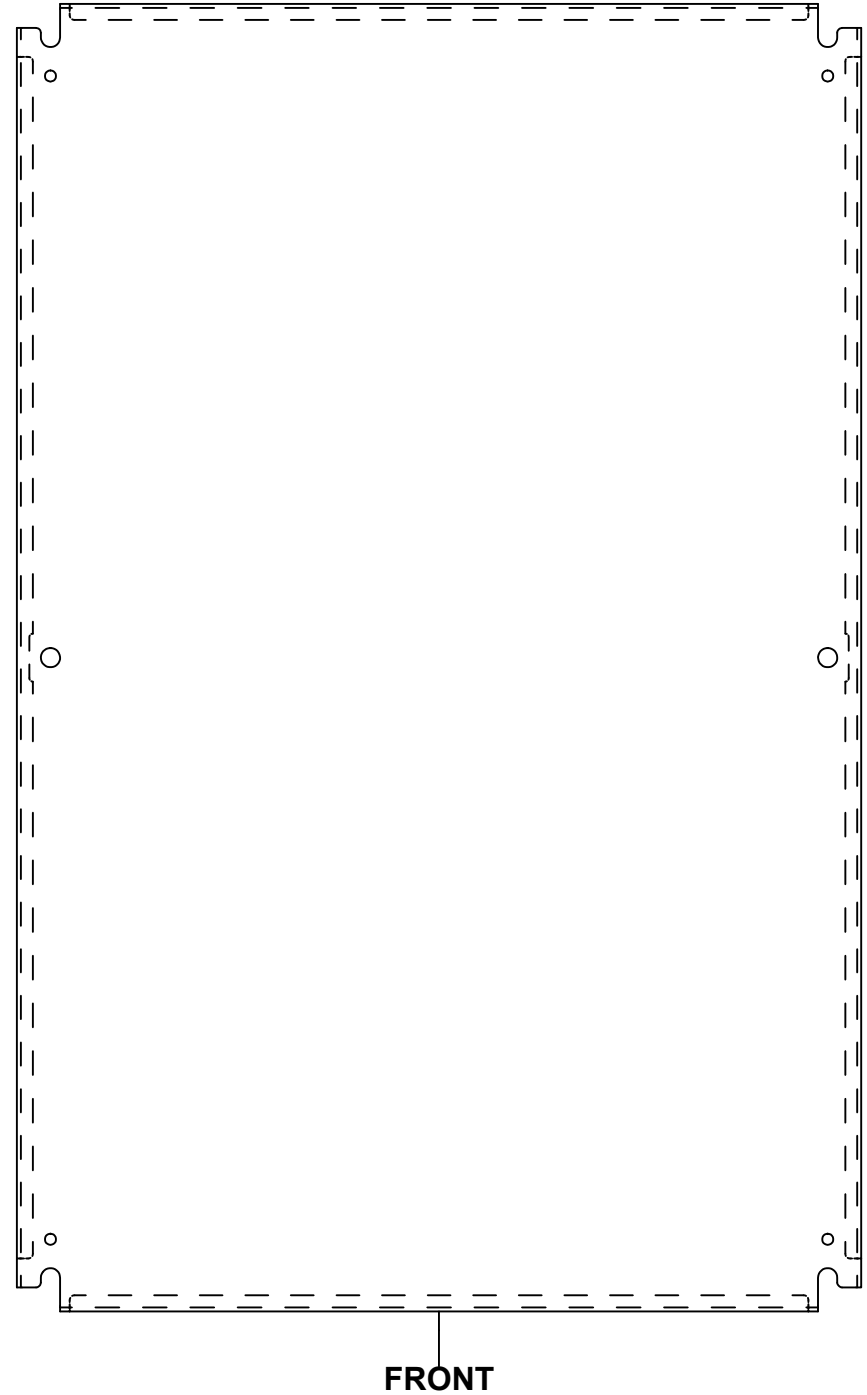
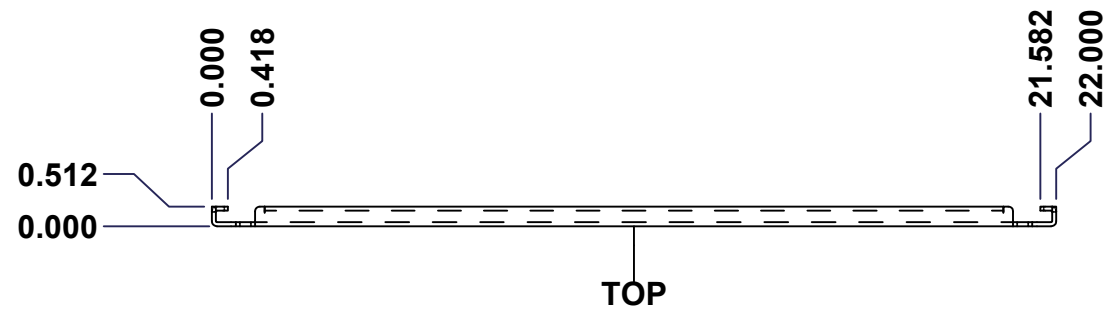

| No. | Revisions | Date | By/Par |
|-----|-----------|------|--------|
|     |           |      |        |
|     |           |      |        |
|     |           |      |        |
|     |           |      |        |
|     |           |      |        |

Isometric View

|                                                              |               |                                                          |
|--------------------------------------------------------------|---------------|----------------------------------------------------------|
| Tél: (450) 979-4373<br>Fax: (450) 979-4626<br>www.exmweb.com |               | Flatness<br>Aplatissement<br>Max 3.0mm<br>Projection<br> |
| Customer<br>Client                                           | Date          |                                                          |
| Drawn By<br>Dessiné Par                                      | BoxCad        | Date 1/23/2007                                           |
| Material<br>Matière                                          | See Part List |                                                          |
| Color<br>Couleur                                             | See Part List | Finish<br>Fini See Part List                             |
| Description                                                  |               | Detail Rev.                                              |
| 881 SP - Inner Panel                                         |               |                                                          |
| Part Number<br>Numéro Pièce                                  | 881 SP3624G   | Rev. 1<br>0                                              |

| Qty | Part Number   | Rev | Description               | Material         | Color     | Finish     |
|-----|---------------|-----|---------------------------|------------------|-----------|------------|
| 1   | 881 SP3624G-P | 0   | 881 SP - Inner Panel Part | 12 Ga Galvanized | Unpainted | Galvanized |

Parts List

This drawing is confidential and must not be reproduced or used without the consent of EXM

Ce dessin est confidentiel et ne doit pas être reproduit ou utilisé sans le consentement de EXM

| Table 1 |        |        | FRONT VIEW                 |
|---------|--------|--------|----------------------------|
| CUT-OUT | XDIM   | YDIM   | DESCRIPTION                |
| 1       | 0.875  | 1.875  | GROUND HOLE (RND Ø0.290)   |
| 2       | 21.125 | 1.875  | GROUND HOLE (RND Ø0.290)   |
| 3       | 0.875  | 32.125 | GROUND HOLE (RND Ø0.290)   |
| 4       | 21.125 | 32.125 | GROUND HOLE (RND Ø0.290)   |
| 5       | 0.875  | 17.000 | MTG STUD HOLE (RND Ø0.500) |
| 6       | 21.125 | 17.000 | MTG STUD HOLE (RND Ø0.500) |

All knockouts are actual size / Les disques défonçables sont grandeur réel

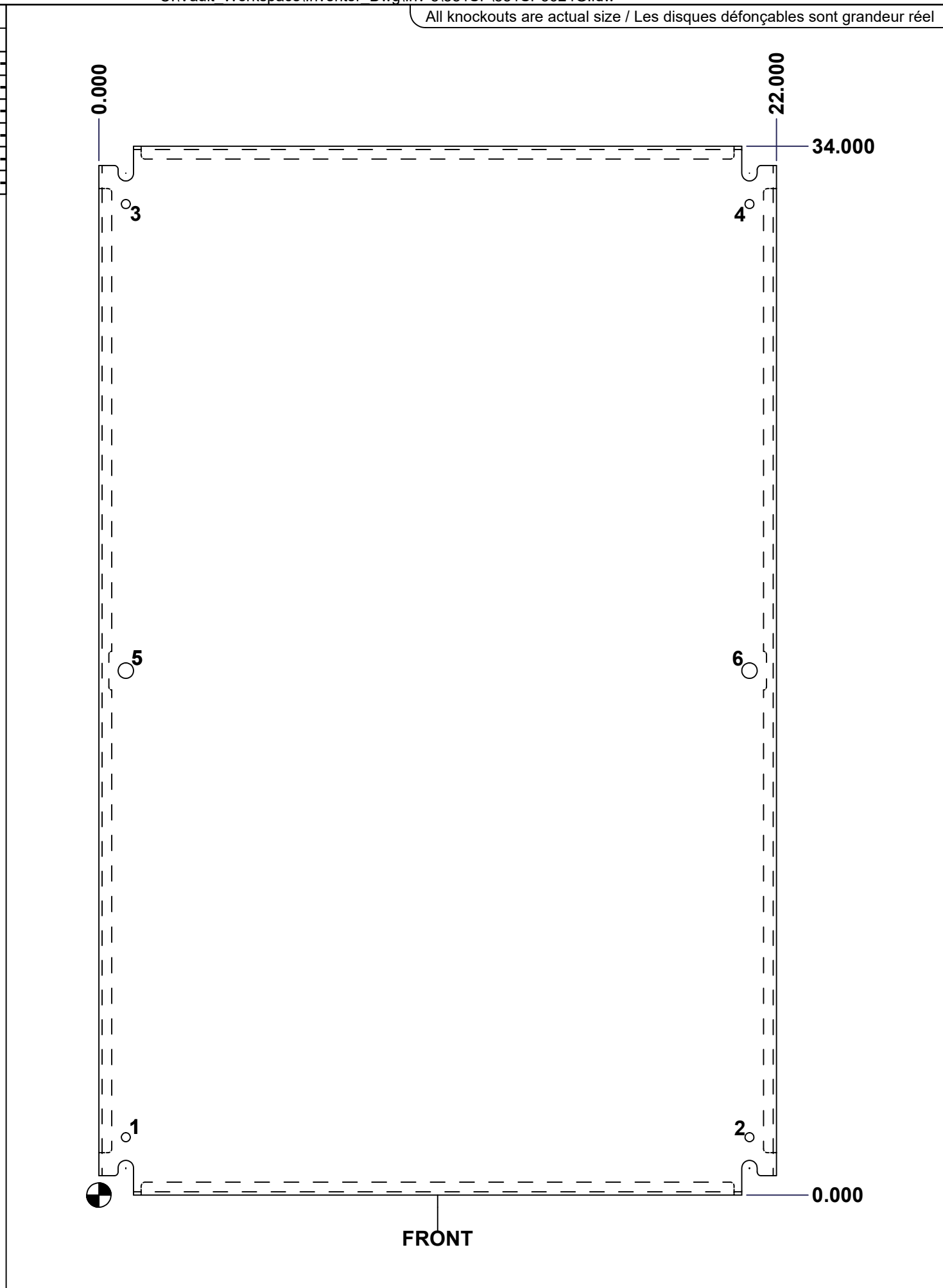

| No. | Revisions | Date | By/Par |
|-----|-----------|------|--------|
|     |           |      |        |
|     |           |      |        |
|     |           |      |        |
|     |           |      |        |
|     |           |      |        |

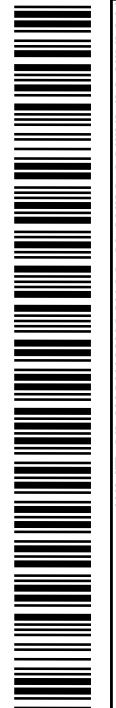
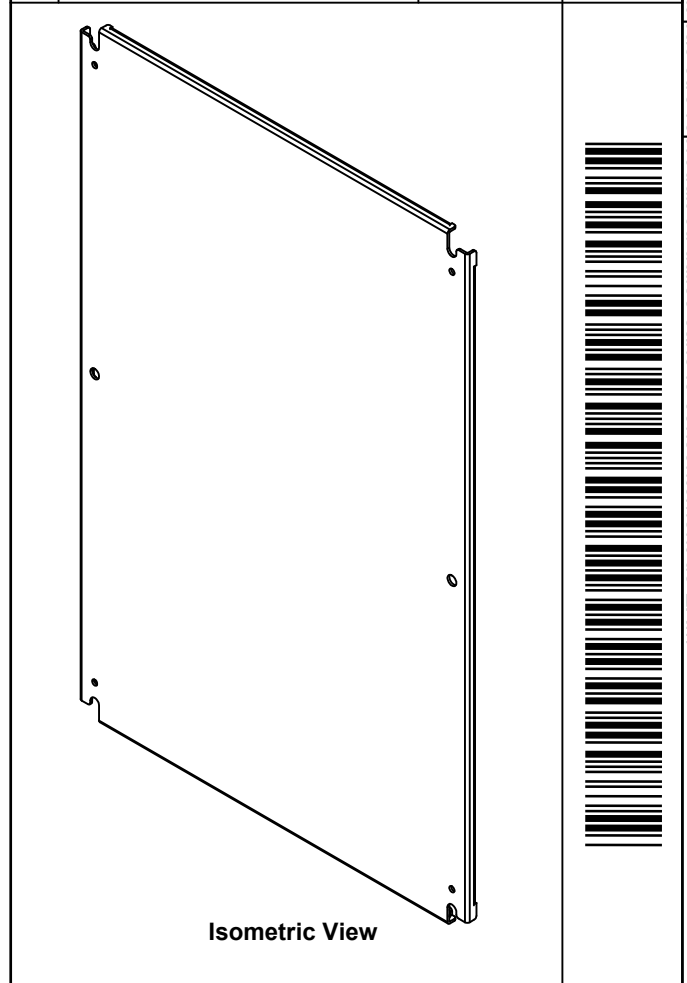

|                                                   |  |                                                              |        |                                        |
|---------------------------------------------------|--|--------------------------------------------------------------|--------|----------------------------------------|
|                                                   |  | Tél: (450) 979-4373<br>Fax: (450) 979-4626<br>www.exmweb.com |        | Flatness<br>Aplatissement<br>Max 3.0mm |
| Customer<br>Client                                |  | Date                                                         |        | Projection<br>                         |
| Drawn By<br>Dessiné Par BoxCad                    |  | Date 1/23/2007                                               |        | Material<br>Matière See Part List      |
| Color<br>Couleur See Part List                    |  | Finish<br>Fini See Part List                                 |        | Description<br>881 SP - Inner Panel    |
| Part Number<br>Numéro Pièce<br><b>881 SP3624G</b> |  | Rev.<br><b>0</b>                                             | 2<br>2 | Detail Rev.                            |