

This drawing is confidential and must not be reproduced or used without the consent of EXM

Ce dessin est confidentiel et ne doit pas être reproduit ou utilisé sans le consentement de EXM

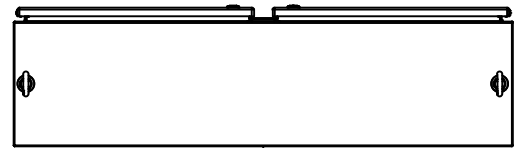

TOP

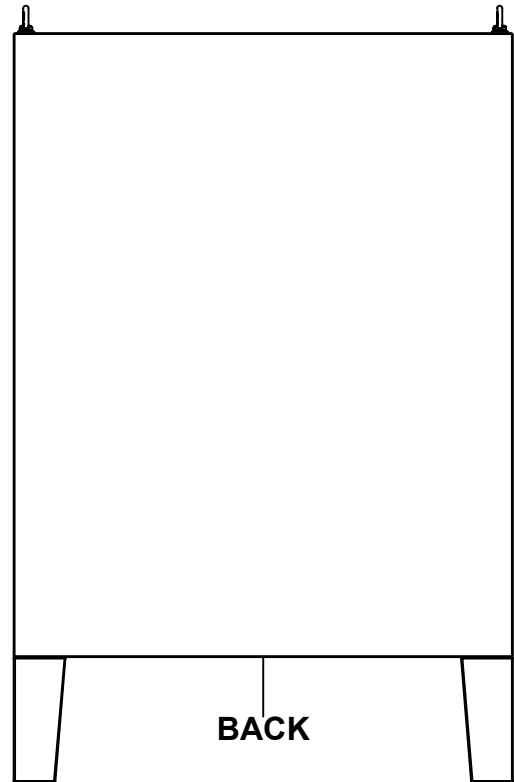

BACK

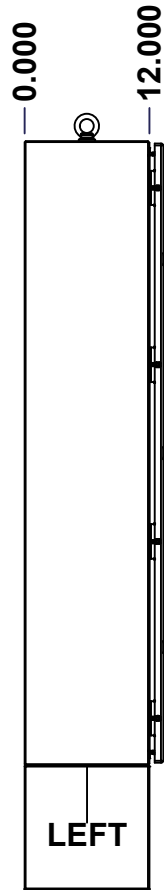

LEFT

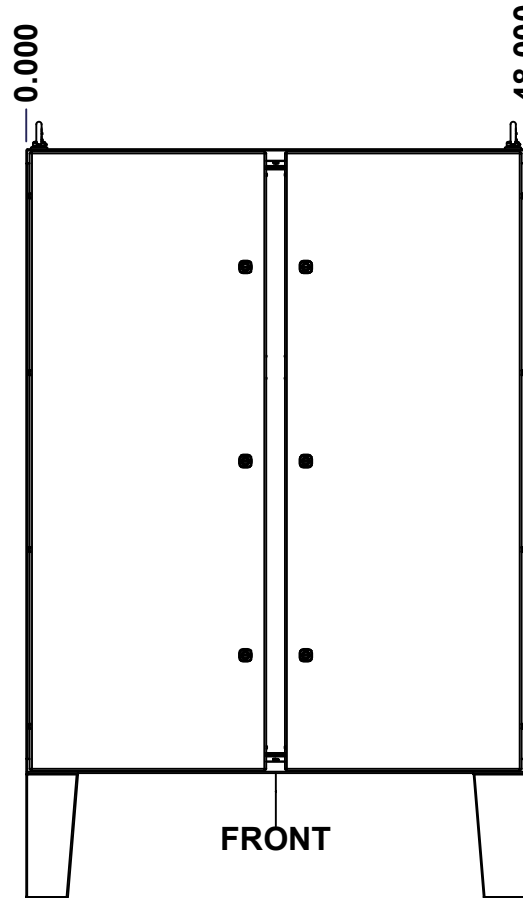

FRONT

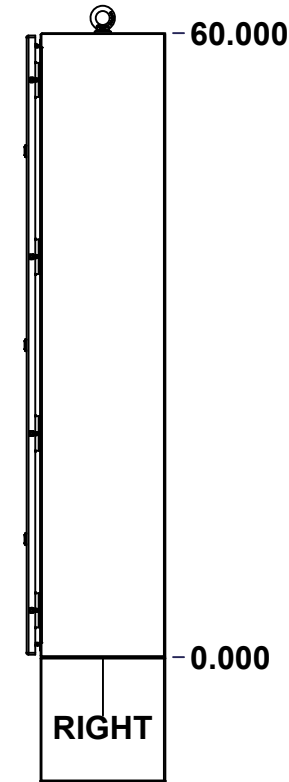

RIGHT



BOTTOM

| No. | Revisions | Date | By/Par |
|-----|-----------|------|--------|
|     |           |      |        |
|     |           |      |        |
|     |           |      |        |
|     |           |      |        |

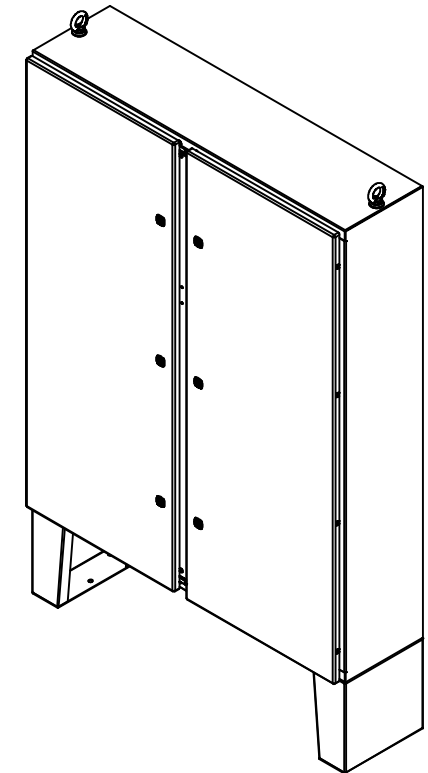

Isometric View



**GRAIN DIRECTION:**  
**TOP/BOTTOM: HORIZONTAL**  
**LEFT/RIGHT/BACK/FRONT: VERTICAL**  
**MOUNTING FEET: VERTICAL**

SEE BILL OF MATERIAL ON LAST PAGE

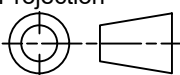
|  |                                   |   |
|--|-----------------------------------|---|
|  Tél: (450) 979-4373<br>Fax: (450) 979-4626<br><a href="http://www.exmweb.com">www.exmweb.com</a> |                                   | Flatness<br>Aplatissement<br>Max 3.0mm<br>Projection<br> |
| Customer<br>Client   | Date                              |   |
| Drawn By<br>Dessiné Par  | BoxCad: BoxCad                    | Date 04-Aug-20  |
| Material<br>Matière  | 12 Ga Stainless Steel 304 (2.5mm) |   |
| Color<br>Couleur   | Unpainted                         | Finish<br>Fini<br>Brushed   |
| Description  | Detail Rev.                       |   |
| 5412SSDD 60" x 48" x 12" Assembly  |                                   |   |
| Part Number<br>Numéro Pièce  | Rev.                              | 1   |
| 5412SSDD604812   | 0                                 | 18  |

This drawing is confidential and must not be reproduced or used without the consent of EXM

Ce dessin est confidentiel et ne doit pas être reproduit ou utilisé sans le consentement de EXM

| NOTE |   |
|------|---|
| ITEM | DESCRIPTION                                     |
| 1    | NEMA 4X Enclosure (IP66)                        |
| 2    | C/W Standard ground studs on box and cover      |
| 3    | C/W Standard door stiffener                     |
| 4    | C/W Standard inner panel (Included)             |
| 5    | C/W Standard inner panel mounting studs         |
| 6    | C/W Eyebolts sold separately (Installed by EXM) |
| 7    | C/W Mounting feet sold separately (Installed)   |
| 8    | C/W Struts installed (Included)                 |
| 9    | C/W Interlock Kit (Installed by EXM)            |

| No. | Revisions | Date | By/Par |
|-----|-----------|------|--------|
|     |           |      |        |
|     |           |      |        |
|     |           |      |        |
|     |           |      |        |
|     |           |      |        |

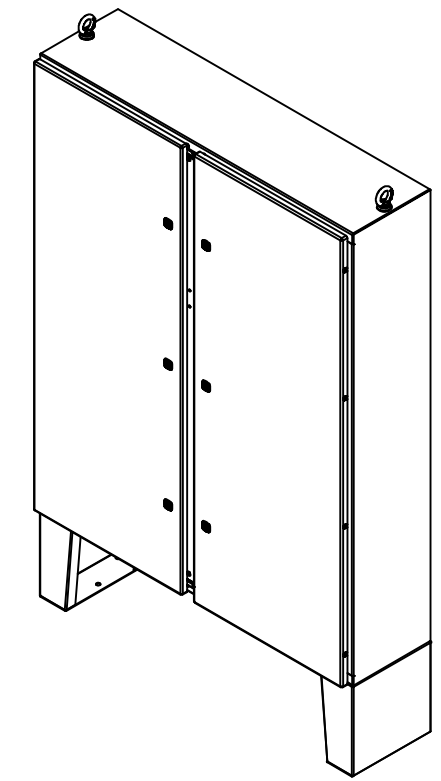

Isometric View

| PACKING               |     |  |
|-----------------------|-----|--|
| ITEM                  | QTY | DESCRIPTION                                    |
| Cardboard sleeve      | 2   | Top and Bottom                                 |
| Cardboard strip       | 2   | Between back of enclosure and inner panel      |
| Plastic bag           | 1   | To protect cover surface and inside gasket     |
| Cardboard corner      | 4   | To reinforced for the plastic strap tightening |
| Plastic strap - Black | 2   | To Squeeze 2 cardboard sleeve together         |
| Packaging label       | 3   | White label with PN                            |
| Plastic strap- Green  | 2   | To secure the enclosure to the wood pallet     |
| Wood Pallet           | 1   | 2" deeper and 3" larger than enclosure size    |

|            |                  |     |  |
|------------|------------------|-----|--|
| 1          | 5412SSDD604812MF | 0   | 885 MFHD 12" x 12" Mounting Feet                                       |
| 8          | STK-Q-07320      | 0   | Flange Lock Nut M10  |
| 1          | 885SP6048G       | 0   | 885 SP6048G Inner Panel  |
| 1          | 880INTI          | 4   | 880 INTI - Interlock Post Kit  |
| 1          | 880EB14SS        | 2   | Stainless Steel Eye Bolt M14 (Pack of 2)                               |
| 8          | STK-Q-07620      | 0   | M10 Plastic Spacer 0.875"  |
| 1          | 5412SSDD604812FD | 0   | 5412SSDD 60" x 48" Master Door   |
| 1          | 5412SSDD604812LD | 0   | 5412SSDD 60" x 48" Slave Door  |
| 1          | 5412SSDD604812B  | 0   | 5412SSDD 60" x 48" x 12" Body  |
| 2          | 5412SSDD604812GP | 0   | 5412SSDD Gland Plate   |
| 8          | STK-Q-04051-07   | 8   | M6 x 7mm Stainless Steel Hexagon Socket Head Machine Screw with Nyseal |
| Qty        | Part Number      | Rev | Description  |
| Parts List |                  |     |  |



Tél: (450) 979-4373  
Fax: (450) 979-4626  
[www.exmweb.com](http://www.exmweb.com)

Flatness  
Aplatissement  
Max 3.0mm

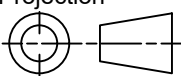
Projection  

|                                   |                                   |
|-----------------------------------|-----------------------------------|
| Customer Client                   | Date                              |
| Drawn By<br>Dessiné Par           | Date 04-Aug-20                    |
| Material<br>Matière               | 12 Ga Stainless Steel 304 (2.5mm) |
| Color<br>Couleur                  | Unpainted                         |
| Finish<br>Fini                    | Brushed                           |
| Description                       | Detail Rev.                       |
| 5412SSDD 60" x 48" x 12" Assembly |                                   |
| Part Number<br>Numéro Pièce       | Rev.                              |
| <b>5412SSDD604812</b>             | <b>0</b>                          |

This drawing is confidential and must not be reproduced or used without the consent of EXM

Ce dessin est confidentiel et ne doit pas être reproduit ou utilisé sans le consentement de EXM

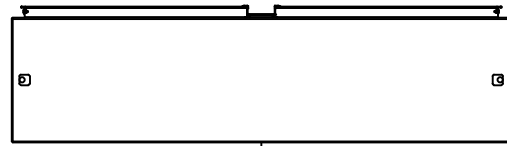

TOP

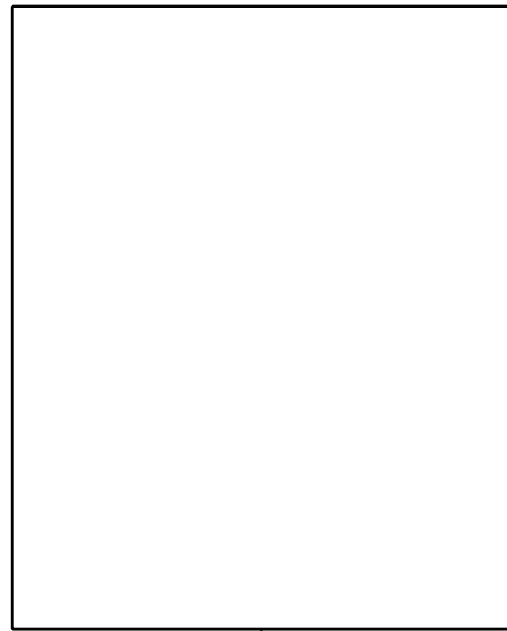

BACK



BOTTOM

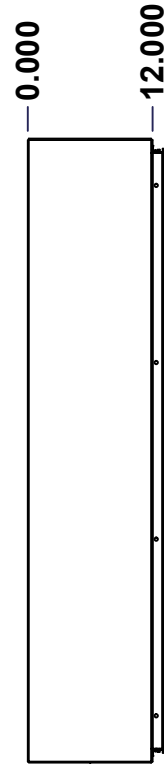

LEFT

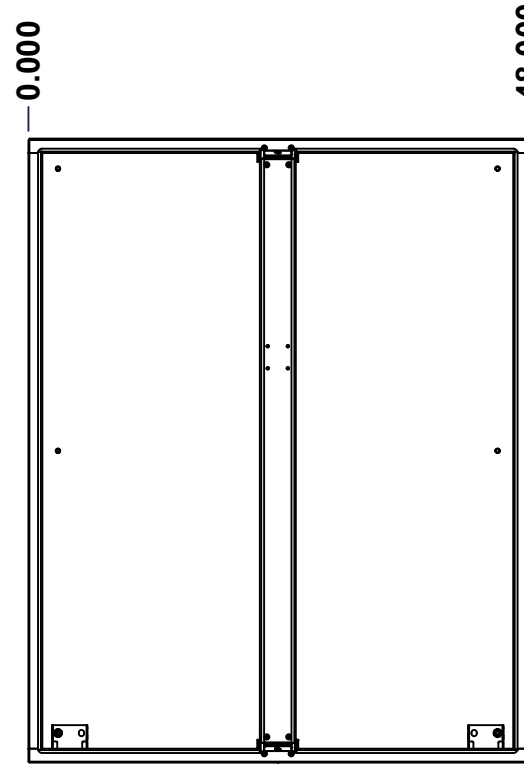

FRONT

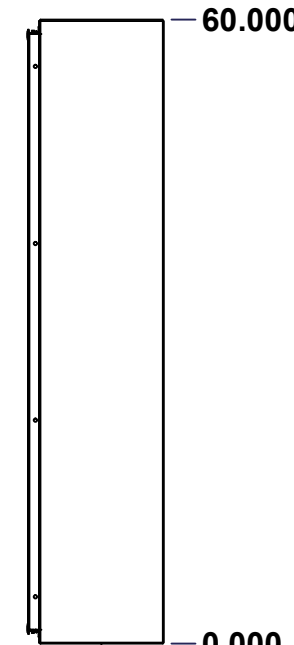

RIGHT

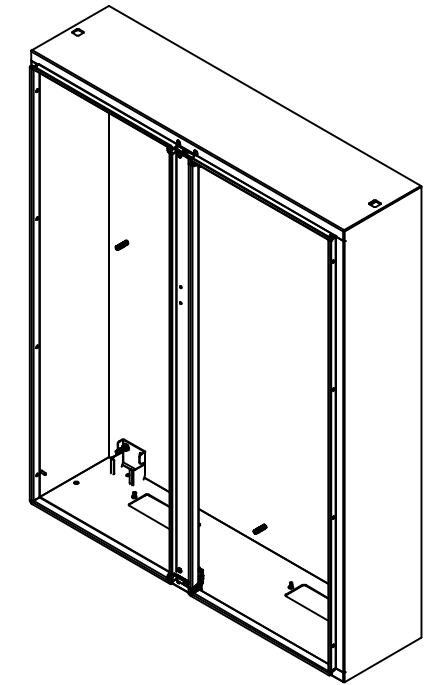

Isometric View

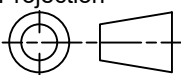

| No. | Revisions | Date | By/Par |
|-----|-----------|------|--------|
|     |           |      |        |
|     |           |      |        |
|     |           |      |        |
|     |           |      |        |

|  |                                   |   |
|--|-----------------------------------|---|
|  Tél: (450) 979-4373<br>Fax: (450) 979-4626<br><a href="http://www.exmweb.com">www.exmweb.com</a> |                                   | Flatness<br>Aplatissement<br>Max 3.0mm<br>Projection<br> |
| Customer Client  | Date                              |   |
| Drawn By<br>Dessiné Par  | BoxCad: BoxCad                    | Date 04-Aug-20  |
| Material<br>Matière  | 12 Ga Stainless Steel 304 (2.5mm) |   |
| Color<br>Couleur   | Unpainted                         | Finish<br>Fini<br>Brushed   |
| Description  | Detail Rev.                       |   |
| 5412SSDD 60" x 48" x 12" Body  |                                   |   |
| Part Number<br>Numéro Pièce  | Rev.                              | 3   |
| 5412SSDD604812B  | 0                                 | 18  |

SEE BILL OF MATERIAL ON LAST PAGE

This drawing is confidential and must not be reproduced or used without the consent of EXM

Ce dessin est confidentiel et ne doit pas être reproduit ou utilisé sans le consentement de EXM

**STANDARD FEATURES ARE NOT LISTED IN THIS HOLE TABLE**

**HOLE TABLE - TOP VIEW (CUSTOM FEATURE ONLY)**

| CUT-OUT | XDIM   | YDIM  | DESCRIPTION                   |
|---------|--------|-------|-------------------------------|
| 1       | 35.895 | 7.895 | Struts CR400 17.500" (Inside) |
| 2       | 11.895 | 7.895 | Struts CR400 17.500" (Inside) |
| 3       | 35.895 | 8.824 | STUDS M6 x 10mm (Inside)      |
| 4       | 44.761 | 7.895 | STUDS M6 x 10mm (Inside)      |
| 5       | 11.895 | 8.824 | STUDS M6 x 10mm (Inside)      |
| 6       | 20.761 | 7.895 | STUDS M6 x 10mm (Inside)      |

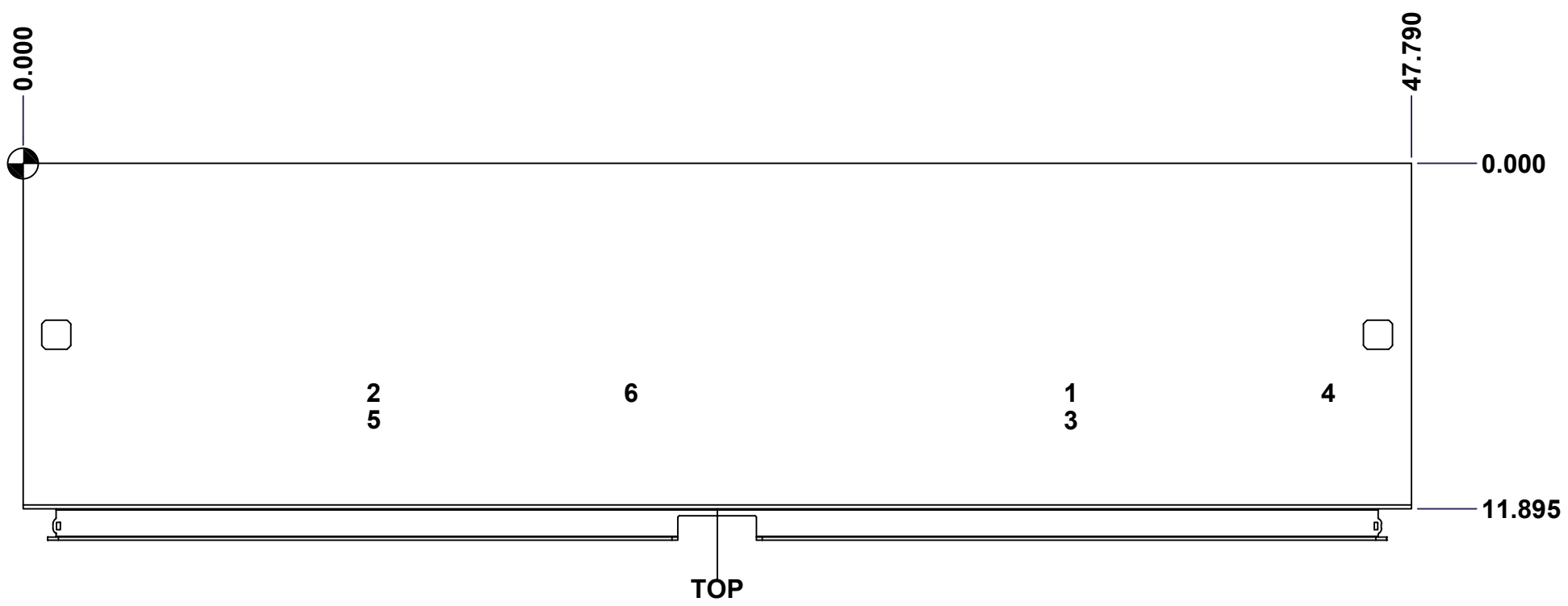

|   |                               |        |
|---|-------------------------------|--------|
|   | Description                   | Status |
|   | 5412SSDD 60" x 48" x 12" Body | (NULL) |
| Part Number<br>Numéro Pièce<br><b>5412SSDD604812B</b> | Rev.                          | 4      |
|   | <b>0</b>                      | 18     |

This drawing is confidential and must not be reproduced or used without the consent of EXM

Ce dessin est confidentiel et ne doit pas être reproduit ou utilisé sans le consentement de EXM

| <b>STANDARD FEATURES ARE NOT LISTED IN THIS HOLE TABLE</b> |        |       |                             |
|--|--------|-------|-----------------------------|
| <b>HOLE TABLE - RIGHT VIEW (CUSTOM FEATURE ONLY)</b>       |        |       |                             |
| CUT-OUT  | XDIM   | YDIM  | DESCRIPTION                 |
| 1  | 10.395 | 3.270 | GND STUD M6 x 16mm (Inside) |

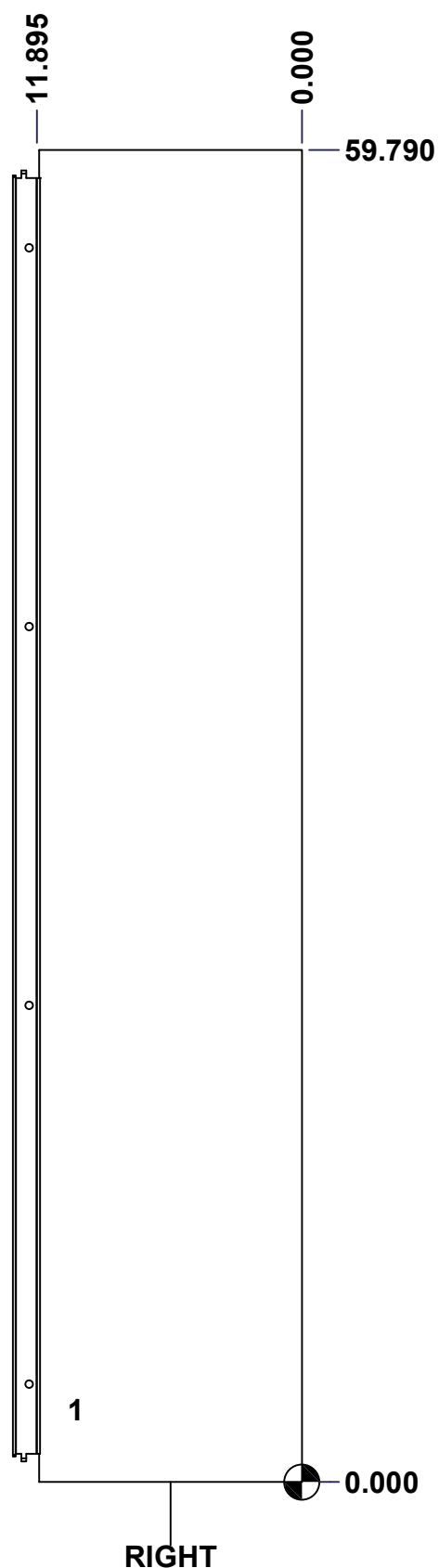

|  |                               |          |
|--|-------------------------------|----------|
|  | Description                   | Status   |
|  | 5412SSDD 60" x 48" x 12" Body | (NULL)   |
|  | Part Number<br>Numéro Pièce   | Rev.     |
|  | <b>5412SSDD604812B</b>        | <b>0</b> |
|  |                               | 5        |
|  |                               | 18       |

This drawing is confidential and must not be reproduced or used without the consent of EXM

Ce dessin est confidentiel et ne doit pas être reproduit ou utilisé sans le consentement de EXM

**STANDARD FEATURES ARE NOT LISTED IN THIS HOLE TABLE**

**HOLE TABLE - BOTTOM VIEW (CUSTOM FEATURE ONLY)**

| CUT-OUT | XDIM   | YDIM   | DESCRIPTION                |
|---------|--------|--------|----------------------------|
| 1       | 7.270  | 3.395  | GP STUD M6 x 16mm (Inside) |
| 2       | 16.520 | 3.395  | GP STUD M6 x 16mm (Inside) |
| 3       | 31.270 | 3.395  | GP STUD M6 x 16mm (Inside) |
| 4       | 40.520 | 3.395  | GP STUD M6 x 16mm (Inside) |
| -----   |        |        |                            |
| 5       | 3.895  | 0.895  | RND Ø0.500                 |
| 6       | 0.895  | 5.895  | RND Ø0.500                 |
| 7       | 3.895  | 10.895 | RND Ø0.500                 |
| 8       | 43.895 | 0.895  | RND Ø0.500                 |
| 9       | 46.895 | 5.895  | RND Ø0.500                 |
| 10      | 43.895 | 10.895 | RND Ø0.500                 |

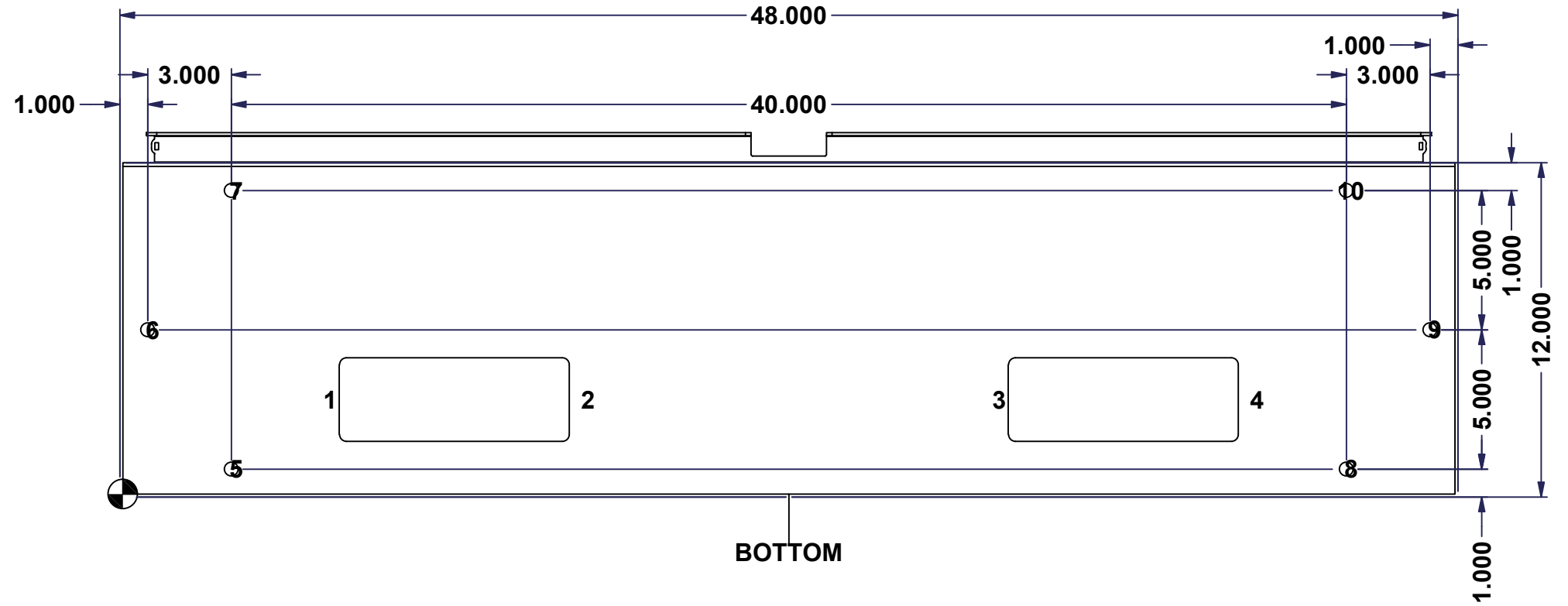

BOTTOM

|  |                               |              |
|--|-------------------------------|--------------|
|  | Description                   | Status       |
|  | 5412SSDD 60" x 48" x 12" Body | (NULL)       |
|  | Part Number<br>Numéro Pièce   | Rev.         |
|  | <b>5412SSDD604812B</b>        | <b>0</b> / 6 |
|  |                               | 18           |

This drawing is confidential and must not be reproduced or used without the consent of EXM

Ce dessin est confidentiel et ne doit pas être reproduit ou utilisé sans le consentement de EXM

| <b>STANDARD FEATURES ARE NOT LISTED IN THIS HOLE TABLE</b> |        |       |                             |
|--|--------|-------|-----------------------------|
| <b>HOLE TABLE - LEFT VIEW (CUSTOM FEATURE ONLY)</b>        |        |       |                             |
| CUT-OUT  | XDIM   | YDIM  | DESCRIPTION                 |
| 1  | 10.395 | 3.270 | GND STUD M6 x 16mm (Inside) |

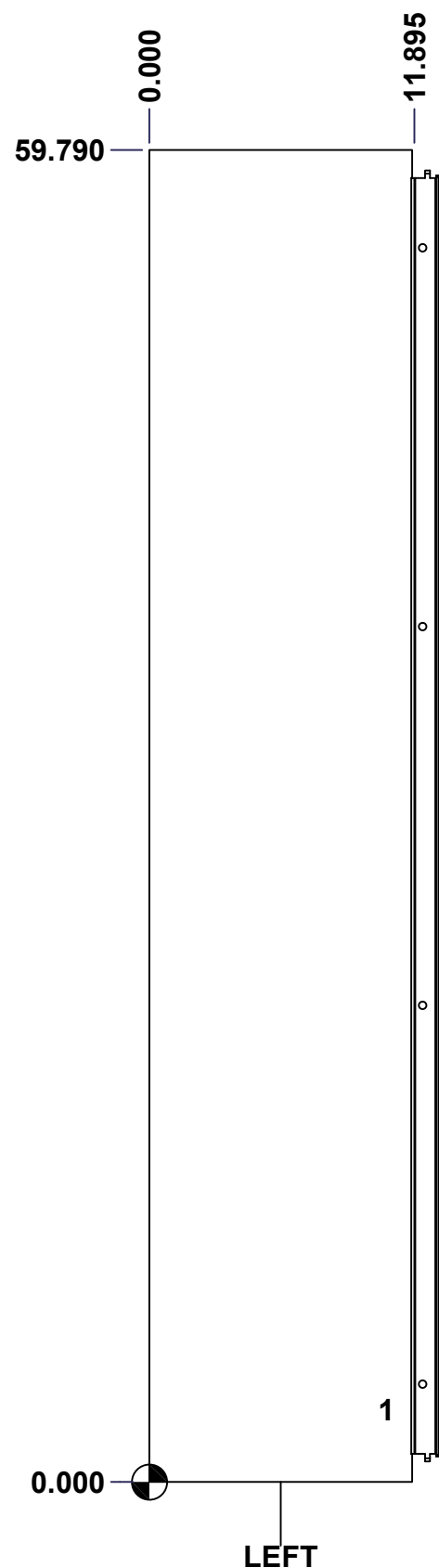

|   |                               |        |
|---|-------------------------------|--------|
|   | Description                   | Status |
|   | 5412SSDD 60" x 48" x 12" Body | (NULL) |
| Part Number<br>Numéro Pièce<br><b>5412SSDD604812B</b> | Rev.                          | 7      |
|   | <b>0</b>                      | 18     |

This drawing is confidential and must not be reproduced or used without the consent of EXM

Ce dessin est confidentiel et ne doit pas être reproduit ou utilisé sans le consentement de EXM

**STANDARD FEATURES ARE NOT LISTED IN THIS HOLE TABLE**

**HOLE TABLE - BACK VIEW (CUSTOM FEATURE ONLY)**

| CUT-OUT | XDIM   | YDIM   | DESCRIPTION                 |
|---------|--------|--------|-----------------------------|
| 1       | 2.770  | 2.770  | IP STUD M10 x 40mm (Inside) |
| 2       | 45.020 | 2.770  | IP STUD M10 x 40mm (Inside) |
| 3       | 2.770  | 29.895 | IP STUD M10 x 40mm (Inside) |
| 4       | 45.020 | 29.895 | IP STUD M10 x 40mm (Inside) |
| 5       | 2.770  | 57.020 | IP STUD M10 x 40mm (Inside) |
| 6       | 45.020 | 57.020 | IP STUD M10 x 40mm (Inside) |
| 7       | 23.895 | 2.770  | IP STUD M10 x 40mm (Inside) |
| 8       | 23.895 | 57.020 | IP STUD M10 x 40mm (Inside) |

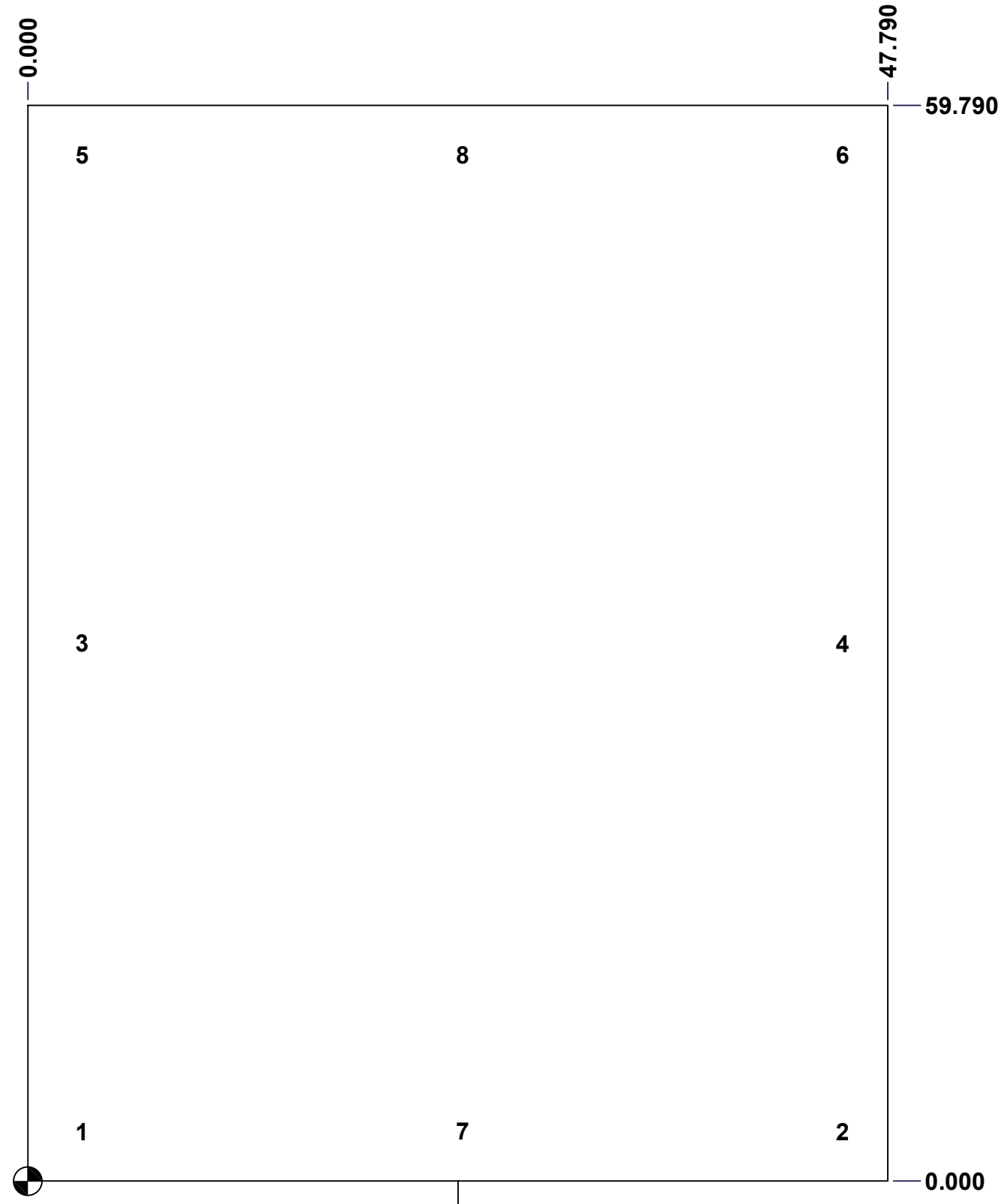

BACK

|  |                               |              |
|--|-------------------------------|--------------|
|  | Description                   | Status       |
|  | 5412SSDD 60" x 48" x 12" Body | (NULL)       |
|  | Part Number<br>Numéro Pièce   | Rev.         |
|  | <b>5412SSDD604812B</b>        | <b>0</b> / 8 |
|  |                               | 18           |



This drawing is confidential and must not be reproduced or used without the consent of EXM

Ce dessin est confidentiel et ne doit pas être reproduit ou utilisé sans le consentement de EXM

**STANDARD FEATURES ARE NOT LISTED IN THIS HOLE TABLE**

**HOLE TABLE - CENTER VIEW (CUSTOM FEATURE ONLY)**

| CUT-OUT | XDIM  | YDIM   | DESCRIPTION            |
|---------|-------|--------|------------------------|
| 1       | 0.748 | 36.220 | PEM FHS-M6-15 (Inside) |
| 2       | 0.748 | 38.346 | PEM FHS-M6-15 (Inside) |
| 3       | 2.717 | 36.220 | PEM FHS-M6-15 (Inside) |
| 4       | 2.717 | 38.346 | PEM FHS-M6-15 (Inside) |

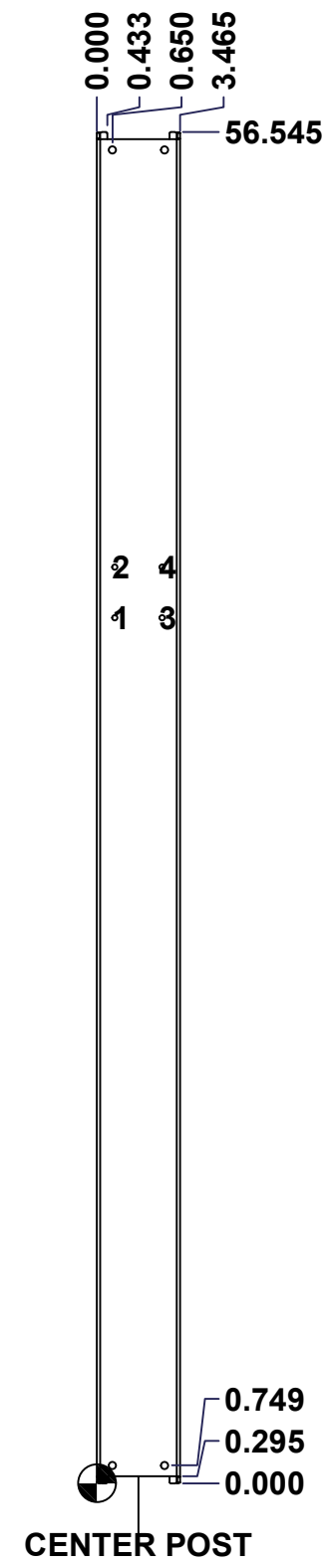

|  |                               |              |
|--|-------------------------------|--------------|
|  | Description                   | Status       |
|  | 5412SSDD 60" x 48" x 12" Body | (NULL)       |
|  | Part Number<br>Numéro Pièce   | Rev.         |
|  | <b>5412SSDD604812B</b>        | <b>0</b> / 9 |
|  |                               | 18           |

This drawing is confidential and must not be reproduced or used without the consent of EXM

Ce dessin est confidentiel et ne doit pas être reproduit ou utilisé sans le consentement de EXM

| No. | Revisions | Date | By/Par |
|-----|-----------|------|--------|
|     |           |      |        |
|     |           |      |        |
|     |           |      |        |
|     |           |      |        |
|     |           |      |        |

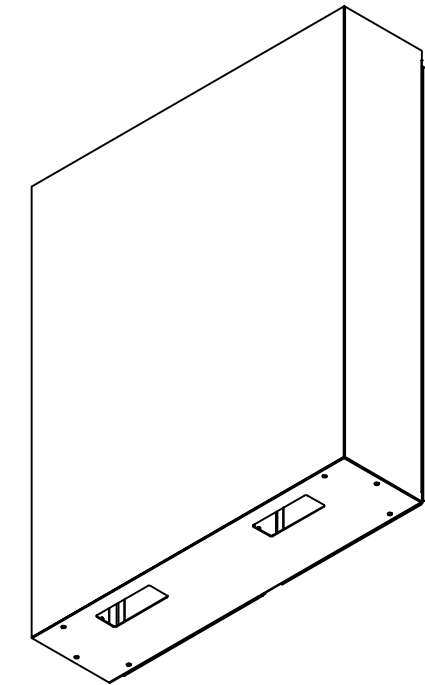

Isometric View



|   |                                 |   |   |
|---|---------------------------------|---|---|
| 4 | STK-Q-16040                     | 0 | Stud M6 x 10mm Stainless Steel  |
| 4 | STK-PEM-FHS-M6-15               | 0 | SS PEM Self-Clinching Stud M6 x 15.0mm                                  |
| 2 | STK-Q-16085                     | 0 | Ground Stud M6 x 16mm Stainless Steel                                   |
| 2 | STK-Q-74905                     | 0 | Stainless Steel 304 Eyebolt Lifting Angle (8.750")                      |
| 4 | STK-Q-16095                     | 0 | M6 x 16mm Stainless Steel Ground Stud                                   |
| 1 | STK-A-75456                     | 2 | Center Post - Stainless Steel Sealing Block with Latch Assembly (Large) |
| 1 | 5412SSDD604812CP-P              | 0 | 5412SSDD 60" Center Post Part   |
| 2 | STK-Q-07320                     | 0 | Flange Lock Nut M10   |
| 2 | STK-Q-07618                     | 1 | 5500 Series Inner Panel Support Bracket                                 |
| 8 | STK-Q-16120                     | 0 | Stud M10 x 40mm Stainless Steel   |
| 1 | 5412SSDD604812BT-P              | 0 | 5412SSDD 48" x 12" Bottom Part  |
| 1 | 5412SSDD604812T-P               | 0 | 5412SSDD 48" x 12" Top Part   |
| 1 | 5412SSDD604812RS-P              | 0 | 5412SSDD 60" x 48" Right Part   |
| 1 | 5412SSDD604812LS-P              | 0 | 5412SSDD 60" x 48" Left Part  |
| 1 | 5412SSDD604812B-P               | 0 | 5412SSDD 60" x 48" Back Part  |
| 2 | 5412SSDD604812_CR400<br>SS_17.5 | 0 | Commercial Roll Stainless Steel (17.5in long)                           |

| Qty        | Part Number | Rev | Description |
|------------|-------------|-----|-------------|
| Parts List |             |     |             |

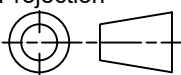
|  |                                   |   |
|--|-----------------------------------|---|
|  Tél: (450) 979-4373<br>Fax: (450) 979-4626<br><a href="http://www.exmweb.com">www.exmweb.com</a> | Flatness<br>Aplatissement         | Max 3.0mm   |
|  | Projection                        |  |
| Customer<br>Client   | Date                              |   |
| Drawn By<br>Dessiné Par  | BoxCad: BoxCad                    | Date 04-Aug-20  |
| Material<br>Matière  | 12 Ga Stainless Steel 304 (2.5mm) |   |
| Color<br>Couleur   | Unpainted                         | Finish<br>Fini Brushed  |
| Description  | Detail Rev.                       |   |
| 5412SSDD 60" x 48" x 12" Body  |                                   |   |
| Part Number<br>Numéro Pièce  | Rev.                              | 10  |
| <b>5412SSDD604812B</b>   | <b>0</b>                          | 18  |

This drawing is confidential and must not be reproduced or used without the consent of EXM

Ce dessin est confidentiel et ne doit pas être reproduit ou utilisé sans le consentement de EXM

| No. | Revisions | Date | By/Par |
|-----|-----------|------|--------|
|     |           |      |        |
|     |           |      |        |
|     |           |      |        |
|     |           |      |        |
|     |           |      |        |

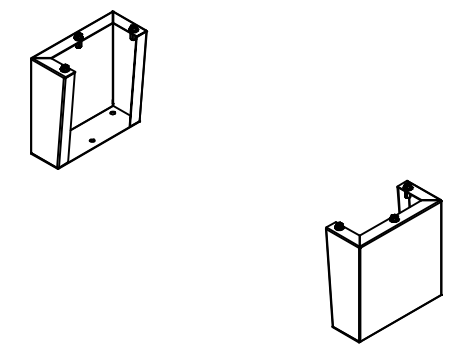
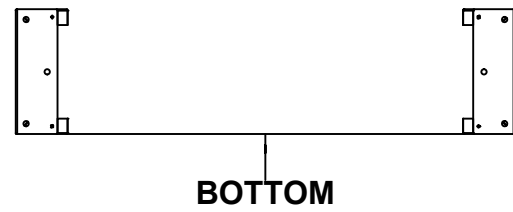
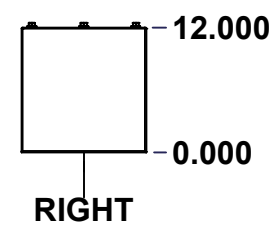
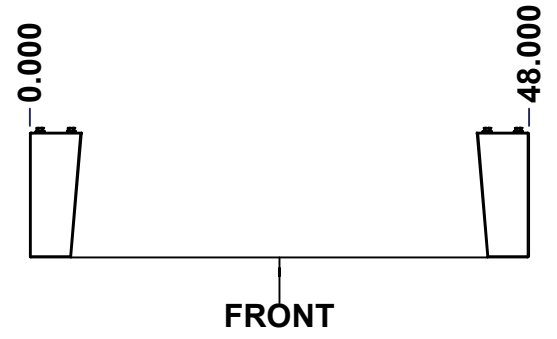
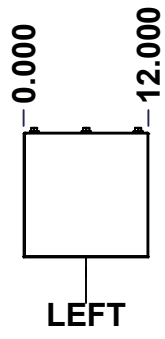
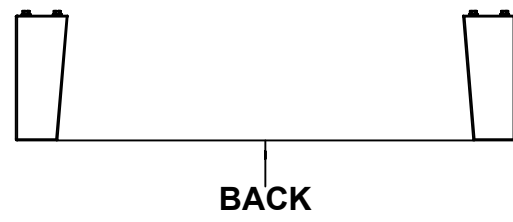
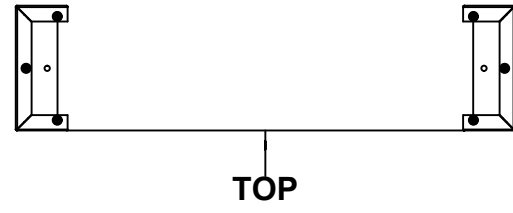

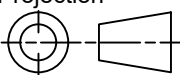
|  |                                   |   |
|--|-----------------------------------|---|
|  Tél: (450) 979-4373<br>Fax: (450) 979-4626<br><a href="http://www.exmweb.com">www.exmweb.com</a> | Flatness<br>Aplatissement         | Max 3.0mm   |
|  | Projection                        |  |
| Customer Client  | Date                              |   |
| Drawn By<br>Dessiné Par  | BoxCad: BoxCad                    | Date 04-Aug-20  |
| Material<br>Matière  | 12 Ga Stainless Steel 304 (2.5mm) |   |
| Color<br>Couleur   | Unpainted                         | Finish<br>Fini Brushed  |
| Description  | Detail Rev.                       |   |
| 885 MFHD 12" x 12" Mounting Feet   |                                   |   |
| Part Number<br>Numéro Pièce  | Rev.                              | 11  |
| <b>5412SSDD604812MF</b>  | <b>0</b>                          | 18  |

**SEE BILL OF MATERIAL ON LAST PAGE**

This drawing is confidential and must not be reproduced or used without the consent of EXM

Ce dessin est confidentiel et ne doit pas être reproduit ou utilisé sans le consentement de EXM

| No. | Revisions | Date | By/Par |
|-----|-----------|------|--------|
|     |           |      |        |
|     |           |      |        |
|     |           |      |        |
|     |           |      |        |
|     |           |      |        |

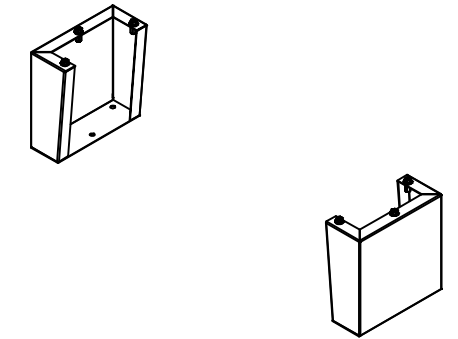

Isometric View

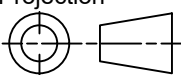

|  |                                   |   |
|--|-----------------------------------|---|
|  Tél: (450) 979-4373<br>Fax: (450) 979-4626<br><a href="http://www.exmweb.com">www.exmweb.com</a> |                                   | Flatness<br>Aplatissement<br>Max 3.0mm<br>Projection<br> |
| Customer Client  | Date                              |   |
| Drawn By<br>Dessiné Par  | BoxCad: BoxCad                    | Date 04-Aug-20  |
| Material<br>Matière  | 12 Ga Stainless Steel 304 (2.5mm) |   |
| Color<br>Couleur   | Unpainted                         | Finish<br>Fini<br>Brushed   |
| Description  |                                   | Detail Rev.   |
| 885 MFHD 12" x 12" Mounting Feet   |                                   |   |
| Part Number<br>Numéro Pièce  | Rev.                              | 12  |
| <b>5412SSDD604812MF</b>  | <b>0</b>                          | 18  |

| Qty        | Part Name                  | Rev | Description   |
|------------|----------------------------|-----|---|
| 6          | RIVET_NUT_SS_M10_FH<br>_CE | 0   | Stainless Steel Rivet Nut M10 (Low Profile Close End) |
| 1          | 5412SSDD604812MFR-P        | 0   | 885 MFHD 12" x 12" Right Mounting Feet Part           |
| 1          | 5412SSDD604812MFL-P        | 0   | 885 MFHD 12" x 12" Left Mounting Feet Part            |
| 3          | STK-K-11610                | 2   | 885 MFSS Accessory Kit                                |
| Parts List |                            |     |   |

This drawing is confidential and must not be reproduced or used without the consent of EXM

Ce dessin est confidentiel et ne doit pas être reproduit ou utilisé sans le consentement de EXM

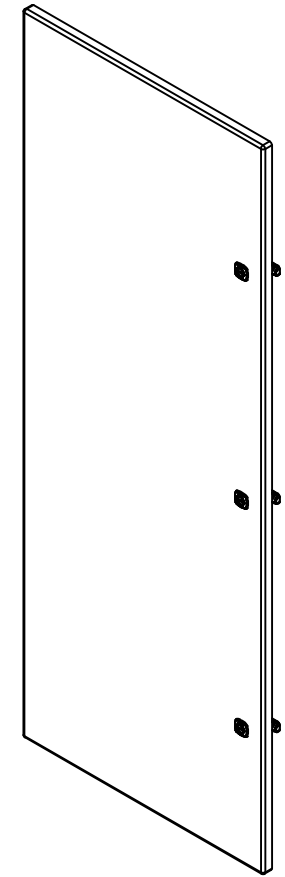
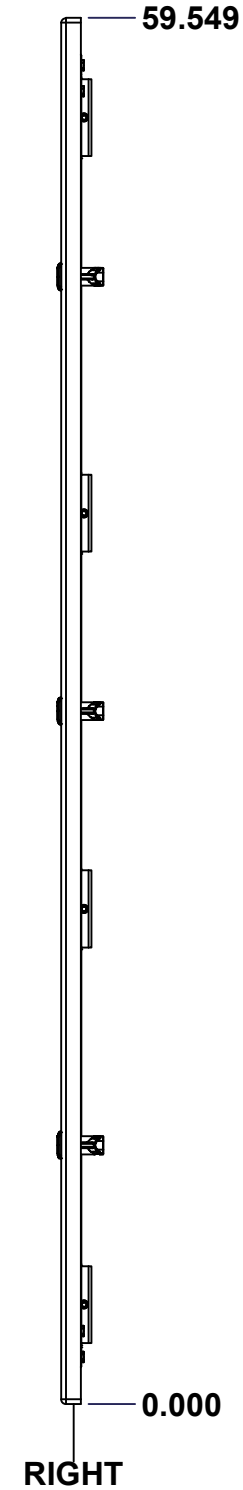
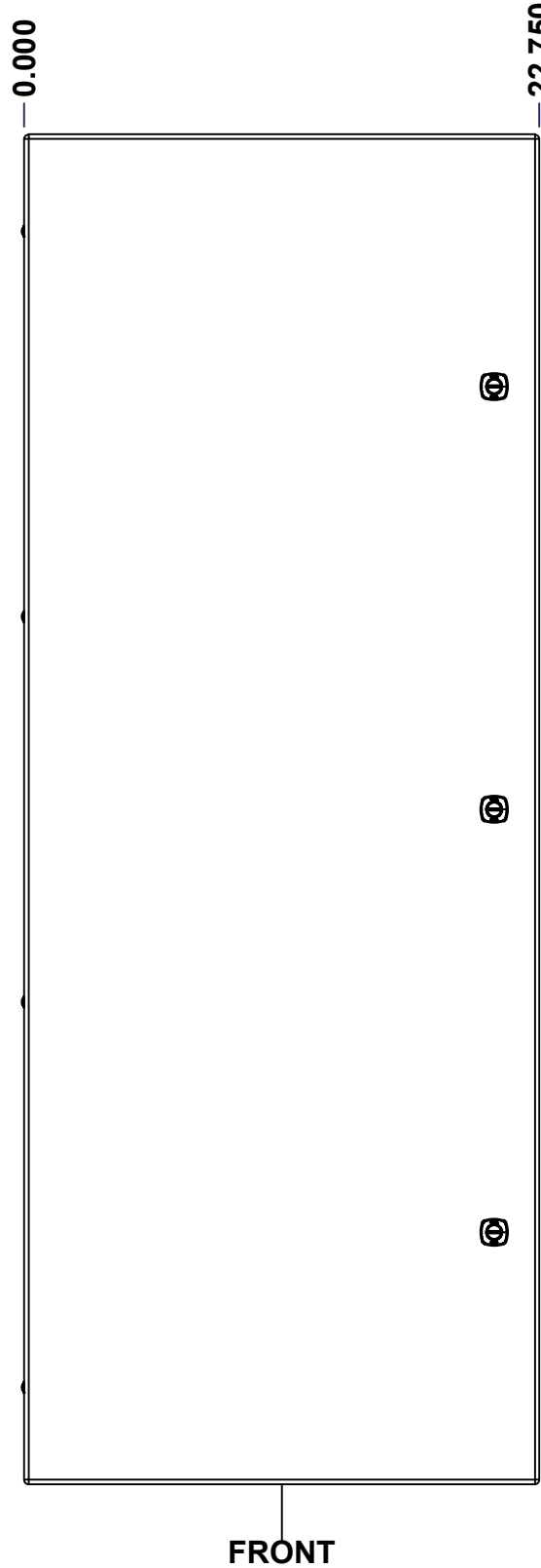
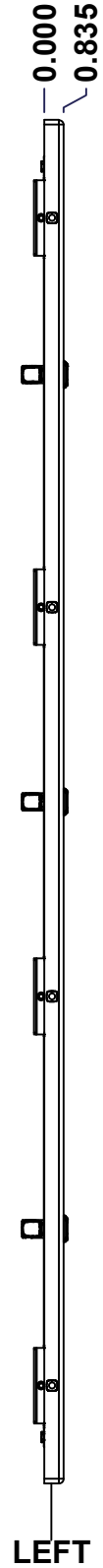
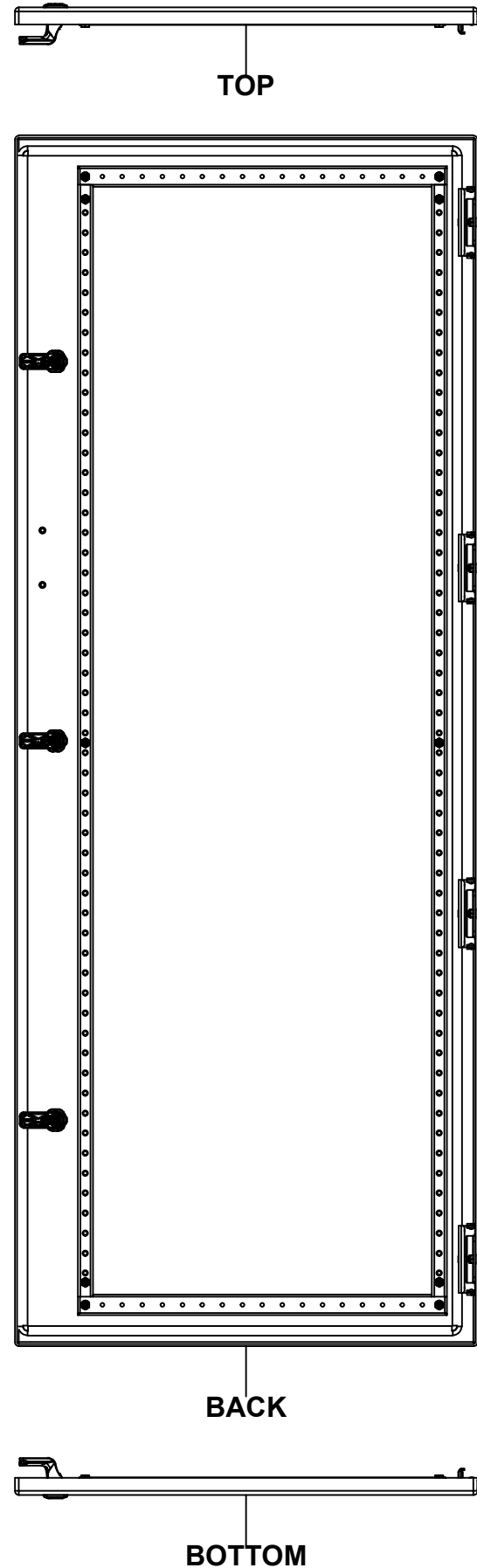

Isometric View

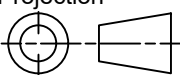

| No. | Revisions | Date | By/Par |
|-----|-----------|------|--------|
|     |           |      |        |
|     |           |      |        |
|     |           |      |        |
|     |           |      |        |

|  |                                   |   |
|--|-----------------------------------|---|
|  Tél: (450) 979-4373<br>Fax: (450) 979-4626<br><a href="http://www.exmweb.com">www.exmweb.com</a> |                                   | Flatness<br>Aplatissement<br>Max 3.0mm<br>Projection<br> |
| Customer Client  | Date                              |   |
| Drawn By<br>Dessiné Par  | BoxCad: BoxCad                    | Date 04-Aug-20  |
| Material<br>Matière  | 12 Ga Stainless Steel 304 (2.5mm) |   |
| Color<br>Couleur   | Unpainted                         | Finish<br>Fini<br>Brushed   |
| Description  | Detail Rev.                       |   |
| 5412SSDD 60" x 48" Slave Door  |                                   |   |
| Part Number<br>Numéro Pièce  | Rev.                              | 13  |
| 5412SSDD604812LD   | 0                                 | 18  |

SEE BILL OF MATERIAL ON LAST PAGE

This drawing is confidential and must not be reproduced or used without the consent of EXM

Ce dessin est confidentiel et ne doit pas être reproduit ou utilisé sans le consentement de EXM

**STANDARD FEATURES ARE NOT LISTED IN THIS HOLE TABLE**

**HOLE TABLE - FRONT VIEW (CUSTOM FEATURE ONLY)**

| CUT-OUT | XDIM   | YDIM   | DESCRIPTION                |
|---------|--------|--------|----------------------------|
| 1       | 1.875  | 2.028  | STUD M6 x 18mm (Inside)    |
| 2       | 1.875  | 29.675 | STUD M6 x 18mm (Inside)    |
| 3       | 1.875  | 57.521 | STUD M6 x 18mm (Inside)    |
| 4       | 1.875  | 3.139  | STUD M6 x 18mm (Inside)    |
| 5       | 1.875  | 56.409 | STUD M6 x 18mm (Inside)    |
| 6       | 19.282 | 2.028  | STUD M6 x 18mm (Inside)    |
| 7       | 19.282 | 29.675 | STUD M6 x 18mm (Inside)    |
| 8       | 19.282 | 57.521 | STUD M6 x 18mm (Inside)    |
| 9       | 19.282 | 3.139  | STUD M6 x 18mm (Inside)    |
| 10      | 19.282 | 56.409 | STUD M6 x 18mm (Inside)    |
| -----   | -----  | -----  | -----                      |
| 11      | 20.750 | 48.430 | LOCK 889 SCQ4-SLSS6 @ 0.0° |
| 12      | 20.750 | 29.774 | LOCK 889 SCQ4-SLSS6 @ 0.0° |
| 13      | 20.750 | 11.118 | LOCK 889 SCQ4-SLSS6 @ 0.0° |
| 14      | 21.402 | 37.445 | STUDS M6 x 18mm (Inside)   |
| 15      | 21.402 | 40.123 | STUDS M6 x 18mm (Inside)   |

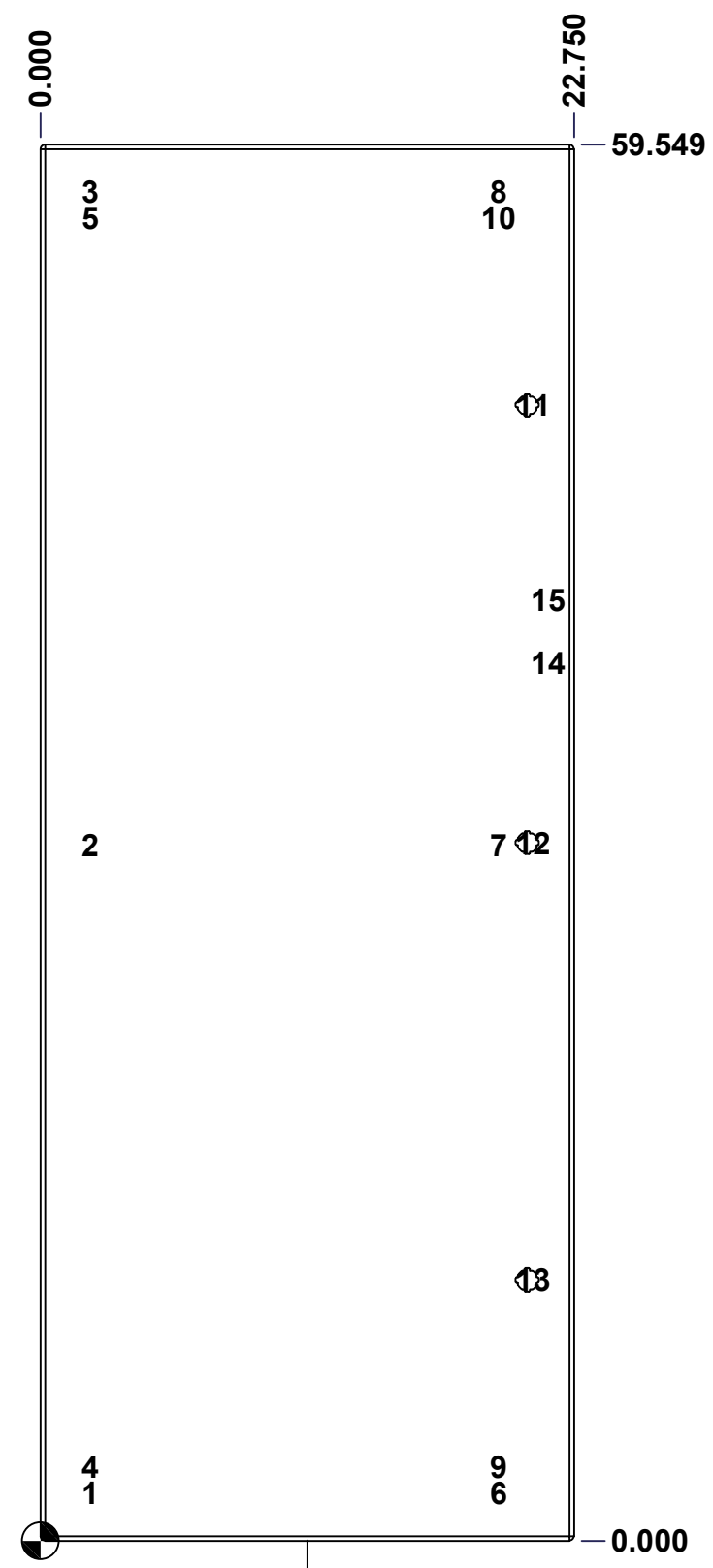

FRONT

|  |                               |               |
|--|-------------------------------|---------------|
|  | Description                   | Status        |
|  | 5412SSDD 60" x 48" Slave Door | (NULL)        |
|  | Part Number<br>Numéro Pièce   | Rev.          |
|  | <b>5412SSDD604812LD</b>       | <b>0</b> / 14 |

This drawing is confidential and must not be reproduced or used without the consent of EXM

Ce dessin est confidentiel et ne doit pas être reproduit ou utilisé sans le consentement de EXM

| No. | Revisions | Date | By/Par |
|-----|-----------|------|--------|
|     |           |      |        |
|     |           |      |        |
|     |           |      |        |
|     |           |      |        |
|     |           |      |        |

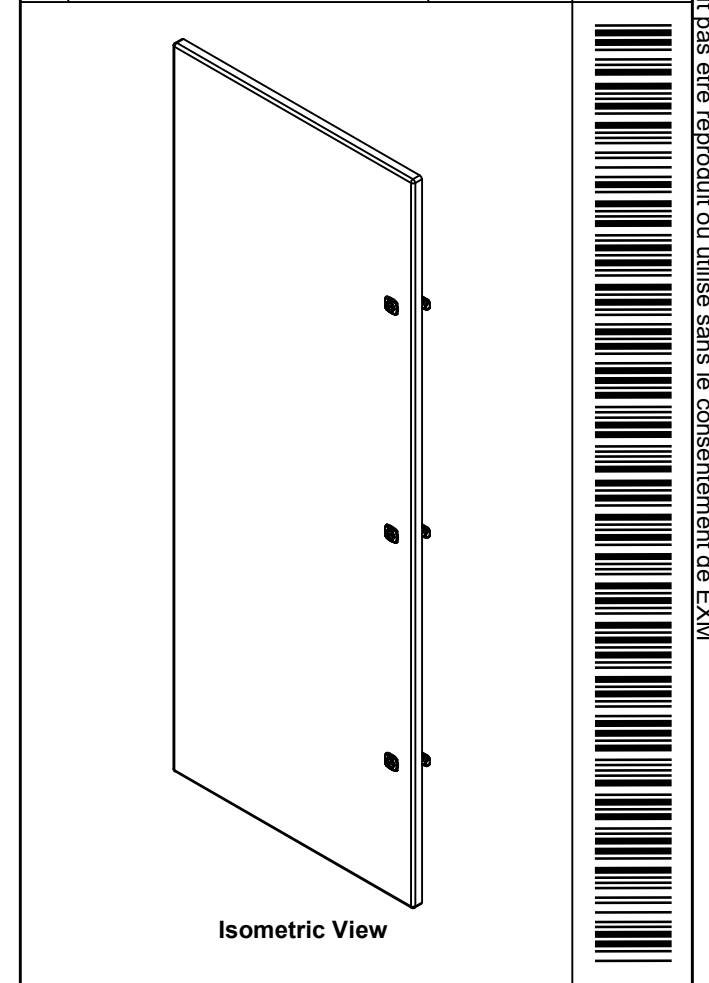

**EXM**  
www.exmweb.com

Tél: (450) 979-4373  
Fax: (450) 979-4626

Flatness  
Aplatissement  
Max 3.0mm

Projection

|  |                |
|--|----------------|
| Customer Client                        | Date           |
| Drawn By<br>Dessiné Par BoxCad: BoxCad | Date 04-Aug-20 |

|                     |                                   |
|---------------------|-----------------------------------|
| Material<br>Matière | 12 Ga Stainless Steel 304 (2.5mm) |
|---------------------|-----------------------------------|

|                  |           |                |         |
|------------------|-----------|----------------|---------|
| Color<br>Couleur | Unpainted | Finish<br>Fini | Brushed |
|------------------|-----------|----------------|---------|

|                               |             |
|-------------------------------|-------------|
| Description                   | Detail Rev. |
| 5412SSDD 60" x 48" Slave Door |             |

|                             |          |    |
|-----------------------------|----------|----|
| Part Number<br>Numéro Pièce | Rev.     | 15 |
| <b>5412SSDD604812LD</b>     | <b>0</b> | 18 |

| QTY        | Part Number        | Rev | Description  |
|------------|--------------------|-----|--|
| 4          | STK-Q-00265        | 0   | M6 x 12mm Stainless Steel 316 Carriage Bolt            |
| 1          | 5412SSDD604812DS1  | 0   | 5412SSDD 60" x 48" Door Stiffener                      |
| 1          | 5412SSDD604812DG   | 0   | 5412SSDD 60" x 48" Door Gasket                         |
| 1          | 5412SSDD604812LD-P | 0   | 5412SSDD 60" x 48" Slave Door Part                     |
| 3          | 889 SCQ4-SLSS6     | 0   | 9412 SS 1/4 Turn Lock                                  |
| 4          | STK-A-33012        | 3   | 5500 SSDD - Stainless Steel Sheet Metal Hinge Assembly |
| 4          | STK-Q-07225        | 0   | M6 Stainless Steel Nylon Insert Lock Nut               |
| 12         | STK-Q-16070        | 1   | Stud M6 x 18mm Stainless steel                         |
| Parts List |                    |     |  |

This drawing is confidential and must not be reproduced or used without the consent of EXM

Ce dessin est confidentiel et ne doit pas être reproduit ou utilisé sans le consentement de EXM

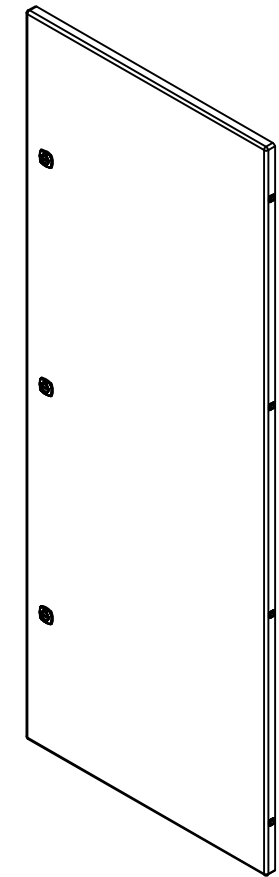
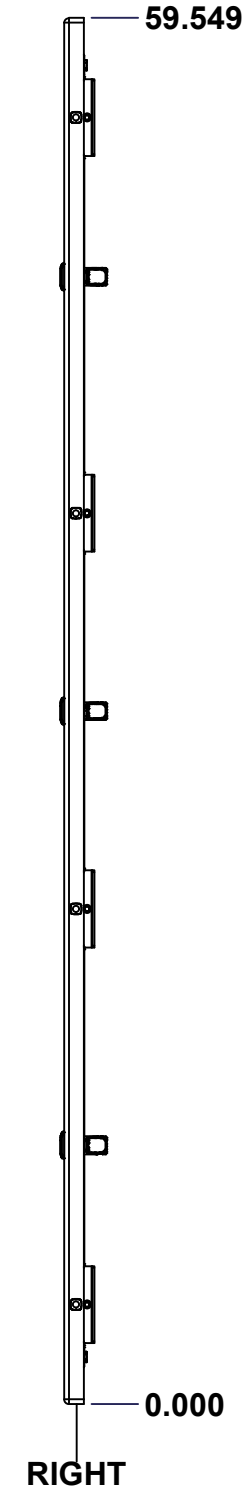
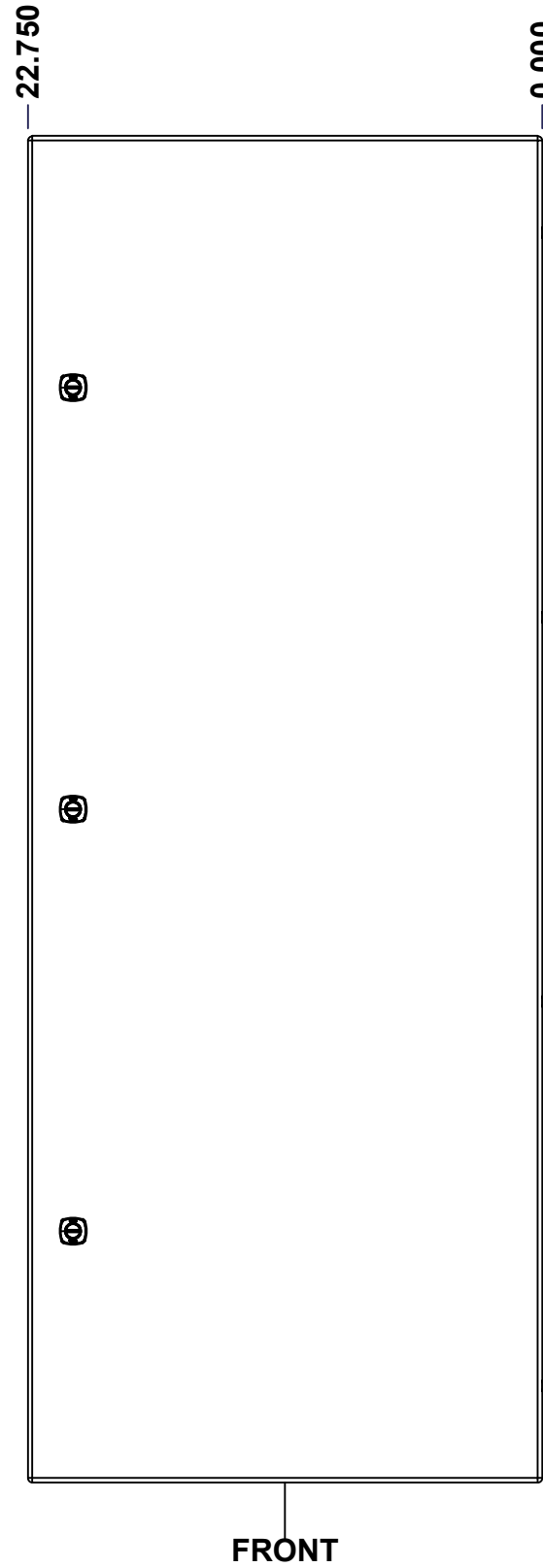
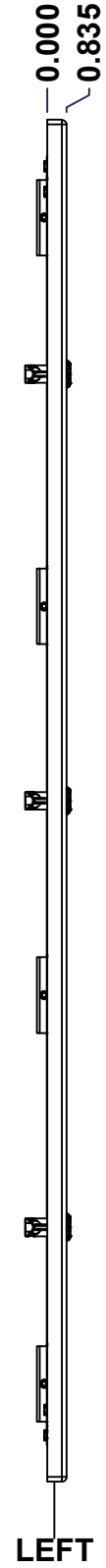
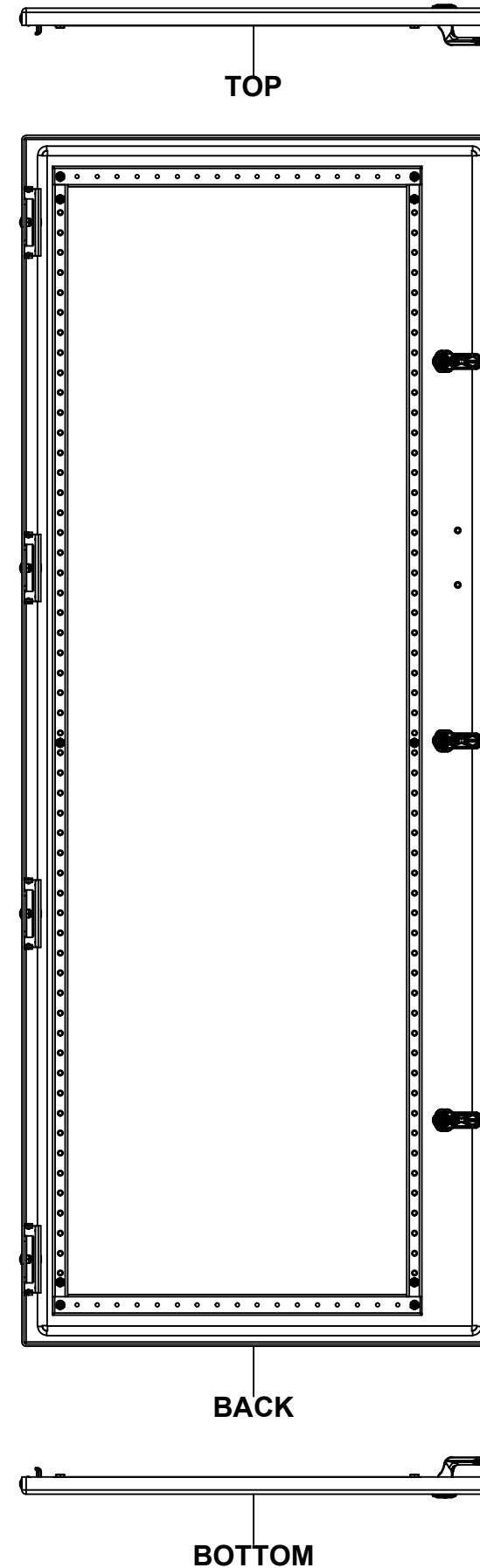

Isometric View

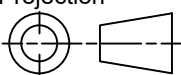

| No. | Revisions | Date | By/Par |
|-----|-----------|------|--------|
|     |           |      |        |
|     |           |      |        |
|     |           |      |        |
|     |           |      |        |
|     |           |      |        |

|  |                                   |   |
|--|-----------------------------------|---|
|  Tél: (450) 979-4373<br>Fax: (450) 979-4626<br><a href="http://www.exmweb.com">www.exmweb.com</a> |                                   | Flatness<br>Aplatissement<br>Max 3.0mm<br>Projection<br> |
| Customer Client  | Date                              |   |
| Drawn By<br>Dessiné Par  | BoxCad: BoxCad                    | Date 04-Aug-20  |
| Material<br>Matière  | 12 Ga Stainless Steel 304 (2.5mm) |   |
| Color<br>Couleur   | Unpainted                         | Finish<br>Fini<br>Brushed   |
| Description  | Detail Rev.                       |   |
| 5412SSDD 60" x 48" Master Door   |                                   |   |
| Part Number<br>Numéro Pièce  | Rev.                              | 16  |
| <b>5412SSDD604812FD</b>  | <b>0</b>                          | 18  |

SEE BILL OF MATERIAL ON LAST PAGE



This drawing is confidential and must not be reproduced or used without the consent of EXM

Ce dessin est confidentiel et ne doit pas être reproduit ou utilisé sans le consentement de EXM

| STANDARD FEATURES ARE NOT LISTED IN THIS HOLE TABLE |        |        |                              |
|---|--------|--------|------------------------------|
| HOLE TABLE - FRONT VIEW (CUSTOM FEATURE ONLY)       |        |        |                              |
| CUT-OUT   | XDIM   | YDIM   | DESCRIPTION                  |
| 1   | 1.875  | 2.028  | STUD M6 x 18mm (Inside)      |
| 2   | 1.875  | 29.675 | STUD M6 x 18mm (Inside)      |
| 3   | 1.875  | 57.521 | STUD M6 x 18mm (Inside)      |
| 4   | 1.875  | 3.139  | STUD M6 x 18mm (Inside)      |
| 5   | 1.875  | 56.409 | STUD M6 x 18mm (Inside)      |
| 6   | 19.282 | 2.028  | STUD M6 x 18mm (Inside)      |
| 7   | 19.282 | 29.675 | STUD M6 x 18mm (Inside)      |
| 8   | 19.282 | 57.521 | STUD M6 x 18mm (Inside)      |
| 9   | 19.282 | 3.139  | STUD M6 x 18mm (Inside)      |
| 10  | 19.282 | 56.409 | STUD M6 x 18mm (Inside)      |
| -----   |        |        |                              |
| 11  | 20.750 | 48.430 | LOCK 889 SCQ4-SLSS6 @ 180.0° |
| 12  | 20.750 | 29.774 | LOCK 889 SCQ4-SLSS6 @ 180.0° |
| 13  | 20.750 | 11.118 | LOCK 889 SCQ4-SLSS6 @ 180.0° |
| 14  | 21.402 | 37.445 | STUDS M6 x 18mm (Inside)     |
| 15  | 21.402 | 40.123 | STUDS M6 x 18mm (Inside)     |

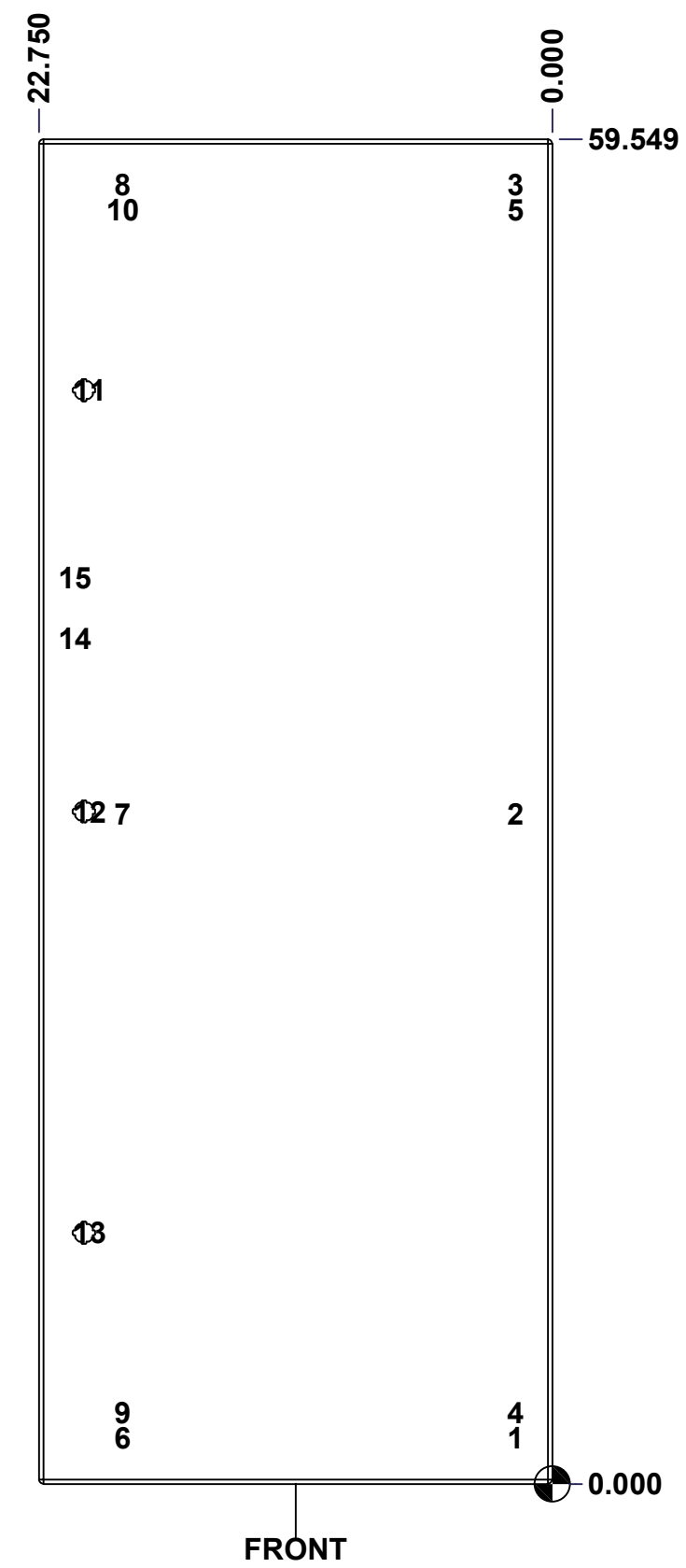



|  |                                |               |
|--|--------------------------------|---------------|
|  | Description                    | Status        |
|  | 5412SSDD 60" x 48" Master Door | (NULL)        |
|  | Part Number<br>Numéro Pièce    | Rev.          |
|  | <b>5412SSDD604812FD</b>        | <b>0</b> / 17 |
|  |                                | 18            |

This drawing is confidential and must not be reproduced or used without the consent of EXM

Ce dessin est confidentiel et ne doit pas être reproduit ou utilisé sans le consentement de EXM

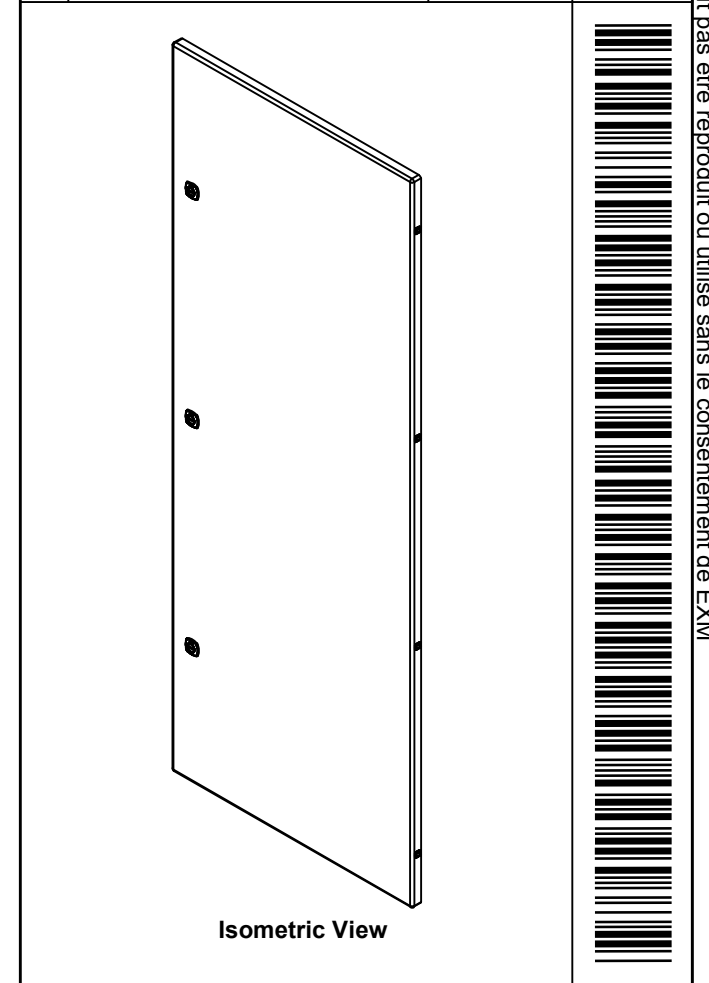
| No. | Revisions | Date | By/Par |
|-----|-----------|------|--------|
|     |           |      |        |
|     |           |      |        |
|     |           |      |        |
|     |           |      |        |
|     |           |      |        |

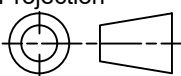

|  |                                   |   |
|--|-----------------------------------|---|
|  Tél: (450) 979-4373<br>Fax: (450) 979-4626<br><a href="http://www.exmweb.com">www.exmweb.com</a> |                                   | Flatness<br>Aplatissement<br>Max 3.0mm<br>Projection<br> |
| Customer<br>Client   | Date                              |   |
| Drawn By<br>Dessiné Par  | BoxCad: BoxCad                    | Date 04-Aug-20  |
| Material<br>Matière  | 12 Ga Stainless Steel 304 (2.5mm) |   |
| Color<br>Couleur   | Unpainted                         | Finish<br>Fini<br>Brushed   |
| Description  |                                   | Detail Rev.   |
| 5412SSDD 60" x 48" Master Door   |                                   |   |
| Part Number<br>Numéro Pièce  | Rev.                              | 18  |
| <b>5412SSDD604812FD</b>  | <b>0</b>                          | 18  |

| 4          | STK-Q-00265        | 0   | M6 x 12mm Stainless Steel 316 Carriage Bolt            |
|------------|--------------------|-----|--|
| 1          | 5412SSDD604812DS1  | 0   | 5412SSDD 60" x 48" Door Stiffener                      |
| 1          | 5412SSDD604812DG   | 0   | 5412SSDD 60" x 48" Door Gasket                         |
| 1          | 5412SSDD604812FD-P | 0   | 5412SSDD 60" x 48" Master Door Part                    |
| 3          | 889 SCQ4-SLSS6     | 0   | 9412 SS 1/4 Turn Lock                                  |
| 4          | STK-A-33012        | 3   | 5500 SSDD - Stainless Steel Sheet Metal Hinge Assembly |
| 4          | STK-Q-07225        | 0   | M6 Stainless Steel Nylon Insert Lock Nut               |
| 12         | STK-Q-16070        | 1   | Stud M6 x 18mm Stainless steel                         |
| QTY        | Part Number        | Rev | Description  |
| Parts List |                    |     |  |

This drawing is confidential and must not be reproduced or used without the consent of EXM

Ce dessin est confidentiel et ne doit pas être reproduit ou utilisé sans le consentement de EXM



TOP

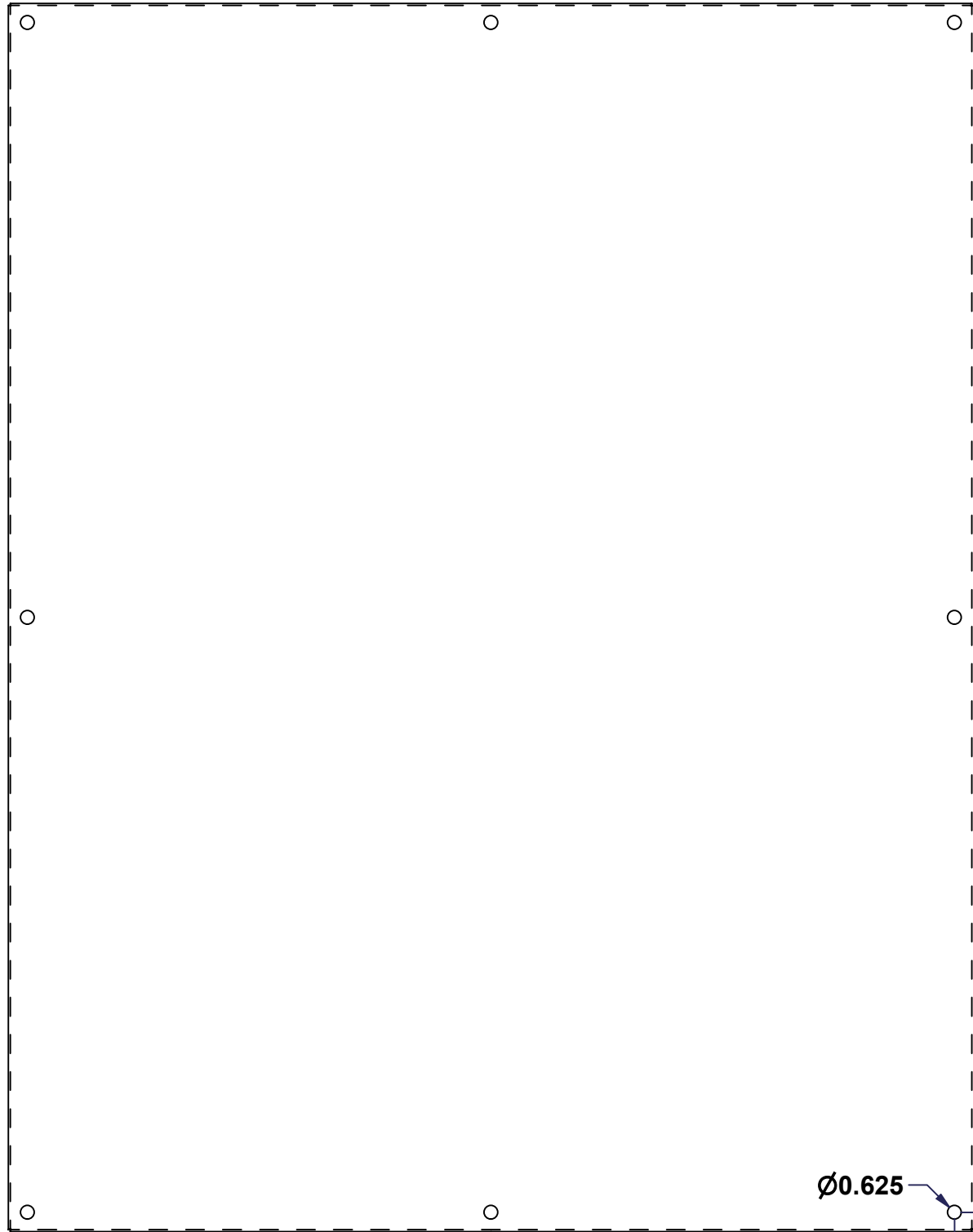

FRONT

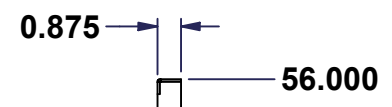

RIGHT

SEE BILL OF MATERIAL ON LAST PAGE

| No. | Revisions | Date | By/Par |
|-----|-----------|------|--------|
|     |           |      |        |
|     |           |      |        |
|     |           |      |        |
|     |           |      |        |
|     |           |      |        |

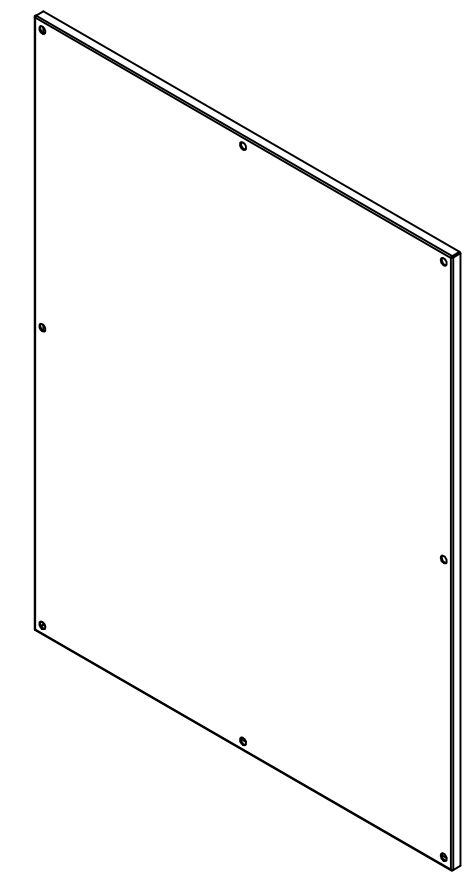

Isometric View



Tél: (450) 979-4373  
 Fax: (450) 979-4626  
 www.exmweb.com

Flatness  
 Aplatissement  
 Max 3.0mm  
 Projection

|                                |                          |
|--------------------------------|--------------------------|
| Customer Client                | Date                     |
| Drawn By<br>Dessiné Par BoxCad | Date 04/11/2009          |
| Material<br>Matière            | 12 Ga Galvanized (2.5mm) |

|                  |           |                |           |
|------------------|-----------|----------------|-----------|
| Color<br>Couleur | Unpainted | Finish<br>Fini | Unpainted |
|------------------|-----------|----------------|-----------|

|                         |             |
|-------------------------|-------------|
| Description             | Detail Rev. |
| 885 SP6048G Inner Panel |             |

|                             |          |   |
|-----------------------------|----------|---|
| Part Number<br>Numéro Pièce | Rev.     | 1 |
| <b>885SP6048G</b>           | <b>0</b> | 2 |

This drawing is confidential and must not be reproduced or used without the consent of EXM

Ce dessin est confidentiel et ne doit pas être reproduit ou utilisé sans le consentement de EXM

| No. | Revisions | Date | By/Par |
|-----|-----------|------|--------|
|     |           |      |        |
|     |           |      |        |
|     |           |      |        |
|     |           |      |        |
|     |           |      |        |

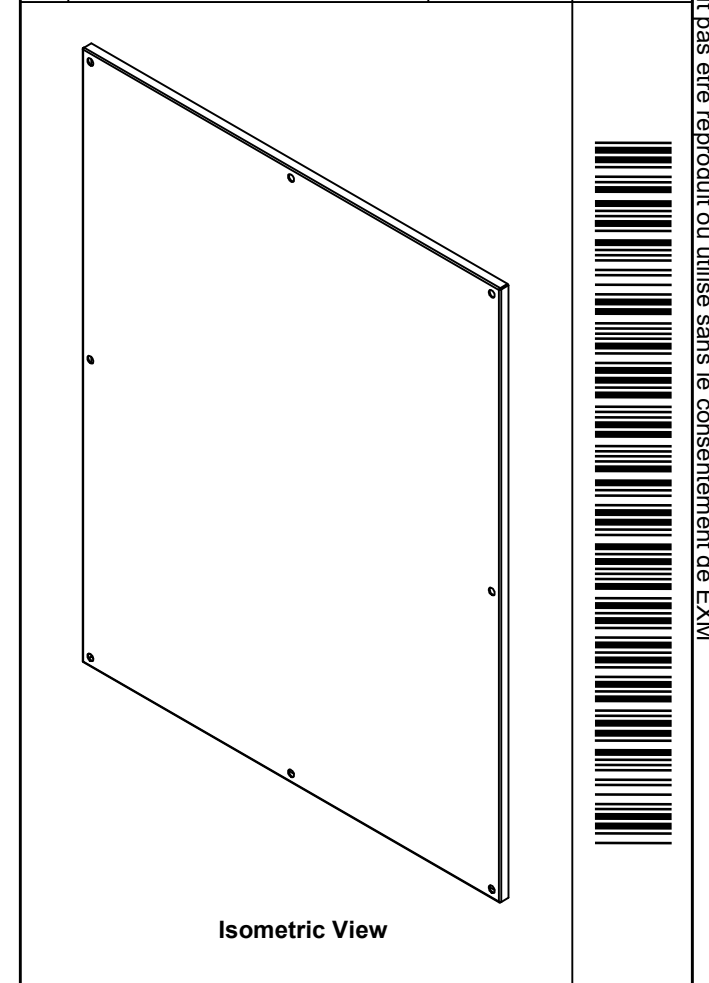

|  |                          |  |
|--|--------------------------|--|
|  Tél: (450) 979-4373<br>Fax: (450) 979-4626<br>www.exmweb.com |                          | Flatness<br>Aplatissement<br>Max 3.0mm |
| Customer Client  |                          | Date                                   |
| Drawn By / Dessiné Par: BoxCad   |                          | Date: 04/11/2009                       |
| Material / Matière: 12 Ga Galvanized (2.5mm)   |                          |  |
| Color / Couleur: Unpainted   | Finish / Fini: Unpainted |  |
| Description: 885 SP6048G Inner Panel   |                          | Detail Rev.                            |
| Part Number / Numéro Pièce: <b>885SP6048G</b>  |                          | Rev. 0 / 2                             |

| Qty        | Part Number  | Rev | Description                  |
|------------|--------------|-----|------------------------------|
| 1          | 885SP6048G-P | 0   | 885 SP6048G Inner Panel Part |
| Parts List |              |     |                              |