

This drawing is confidential and must not be reproduced or used without the consent of EXM

Ce dessin est confidentiel et ne doit pas être reproduit ou utilisé sans le consentement de EXM

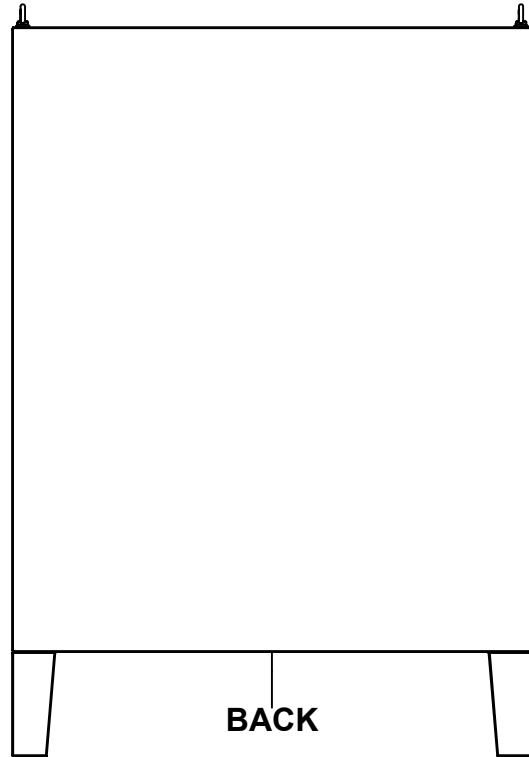

TOP



BACK

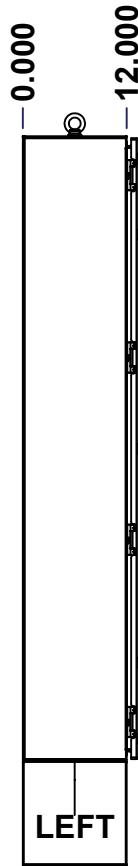

LEFT

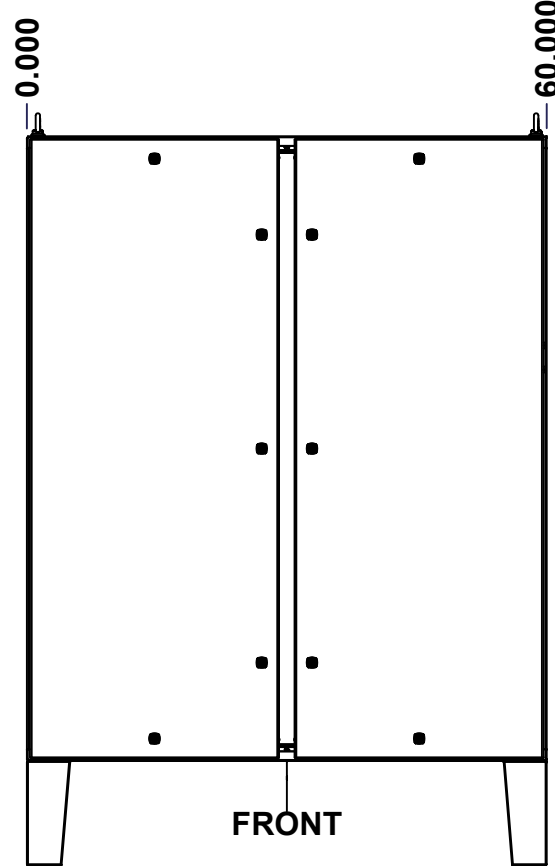

FRONT

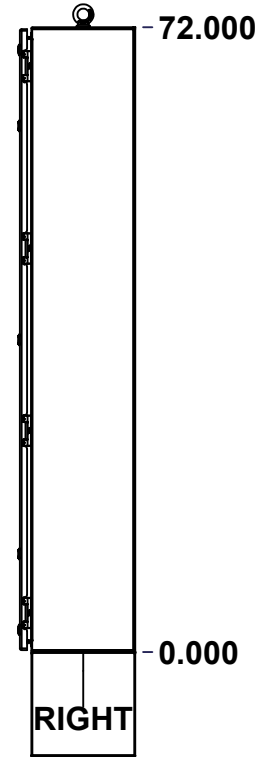

RIGHT

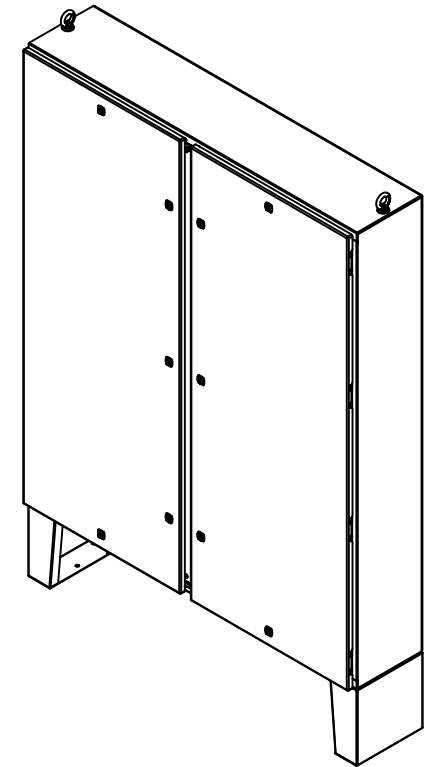

Isometric View



BOTTOM

**GRAIN DIRECTION:
TOP/BOTTOM: HORIZONTAL
LEFT/RIGHT/BACK/FRONT: VERTICAL**

SEE BILL OF MATERIAL ON LAST PAGE

No.	Revisions	Date	By/Par

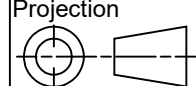
 Tél: (450) 979-4373 Fax: (450) 979-4626 www.exmweb.com		Flatness Aplatissement Max 3.0mm Projection 
Customer Client	Date	Date
Drawn By Dessiné Par	BoxCad: BoxCad	21-Oct-19
Material Matière	12 Ga Stainless Steel 304 (2.5mm)	
Color Couleur	Unpainted	Finish Fini Brushed
Description	5412SSDD 72" x 60" x 12" Assembly	
Part Number Numéro Pièce	Rev. 0	1 2

This drawing is confidential and must not be reproduced or used without the consent of EXM

Ce dessin est confidentiel et ne doit pas être reproduit ou utilisé sans le consentement de EXM

NOTE

ITEM	DESCRIPTION
1	NEMA 4X Enclosure
2	C/W Standard ground studs on box and cover
3	C/W Standard door stiffener
4	C/W Standard inner panel (Included)
5	C/W Standard inner panel mounting studs
6	C/W Eyebolts
7	C/W Mounting feet sold separately (Installed)
8	C/W Struts installed (Included)

No.	Revisions	Date	By/Par

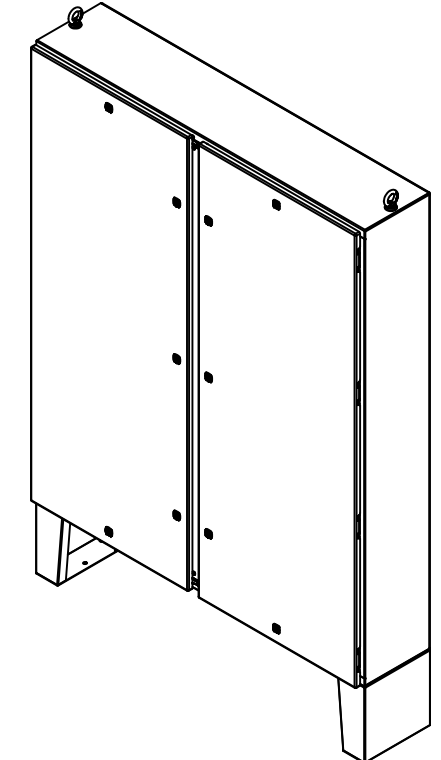

Isometric View





Tél: (450) 979-4373
Fax: (450) 979-4626
www.exmweb.com

Flatness
Aplatissement
Max 3.0mm
Projection

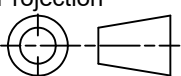

Customer
Client

Date

Drawn By
Dessiné Par BoxCad: BoxCad

Date 21-Oct-19

Material
Matière

12 Ga Stainless Steel 304 (2.5mm)

Color
Couleur

Unpainted

Finish
Fini

Brushed

Description

Detail Rev.

5412SSDD 72" x 60" x 12" Assembly

Part Number
Numéro Pièce

Rev. 2

5412SSDD726012

0

Qty	Part Number	Rev	Description
1	5412SSDD726012MF	0	885 MFHD 12" x 12" Mounting Feet
1	880INT1	2	880 INT1 - Interlock Post Kit
1	880EB14SS	2	Stainless Steel Eye Bolt M14 (Pack of 2)
8	STK-Q-07320	0	Flange Lock Nut M10
1	885SP7260G	0	885 SP7260G Inner Panel
6	STK-Q-07620	0	M10 Plastic Spacer 0.875"
1	5412SSDD726012FD	0	5412SSDD 72" x 60" Master Door
1	5412SSDD726012LD	0	5412SSDD 72" x 60" Slave Door
1	5412SSDD726012B	0	5412SSDD 72" x 60" x 12" Body
2	5412SSDD726012GP	0	5412SSDD Gland Plate
8	STK-Q-04051-10	8	M6 Hexagon Socket Head Machine Screw with Nyseal
Parts List			

PACKING		
ITEM	QTY	DESCRIPTION
Cardboard sleeve	2	Top and Bottom
Cardboard strip	2	Between back of enclosure and inner panel
Plastic bag	1	To protect cover surface and inside gasket
Cardboard corner	4	To reinforced for the plastic strap tightening
Plastic strap - Black	2	To Squeeze 2 cardboard sleeve together
Packaging label	3	White label with PN
Plastic strap- Green	2	To secure the enclosure to the wood pallet
Wood Pallet	1	2" deeper and 3" larger than enclosure size

This drawing is confidential and must not be reproduced or used without the consent of EXM

Ce dessin est confidentiel et ne doit pas être reproduit ou utilisé sans le consentement de EXM

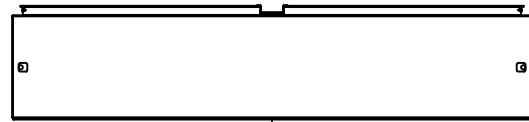

TOP

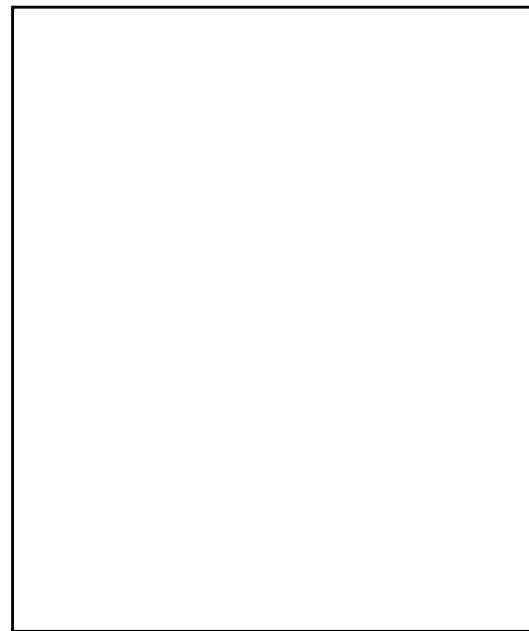

BACK

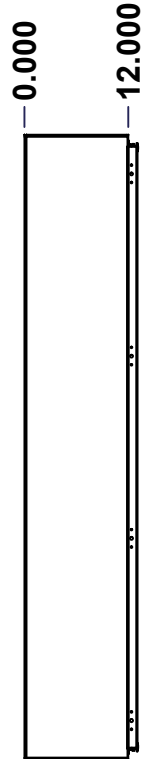

LEFT

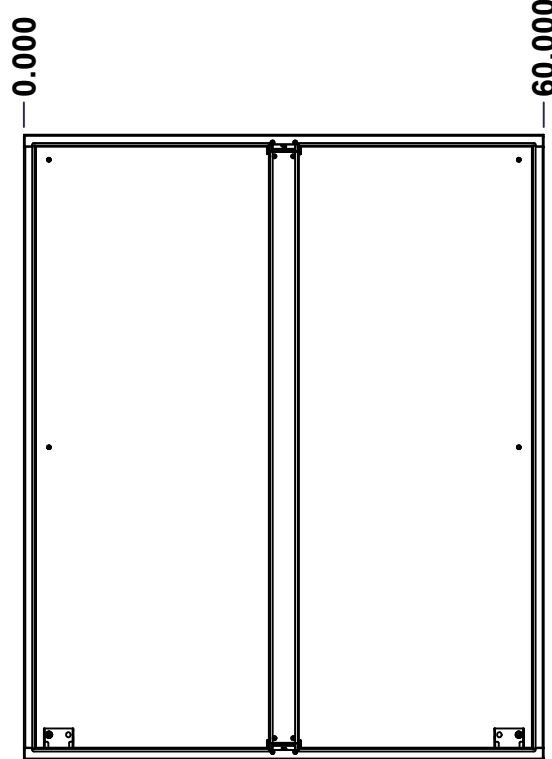

FRONT

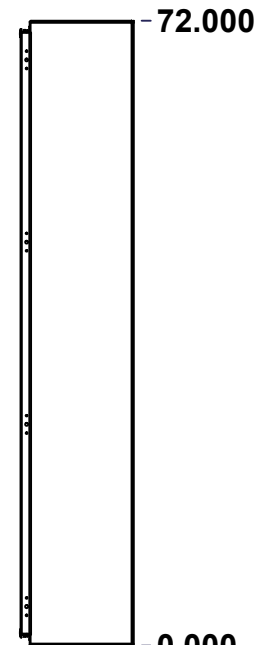

RIGHT



BOTTOM

No.	Revisions	Date	By/Par

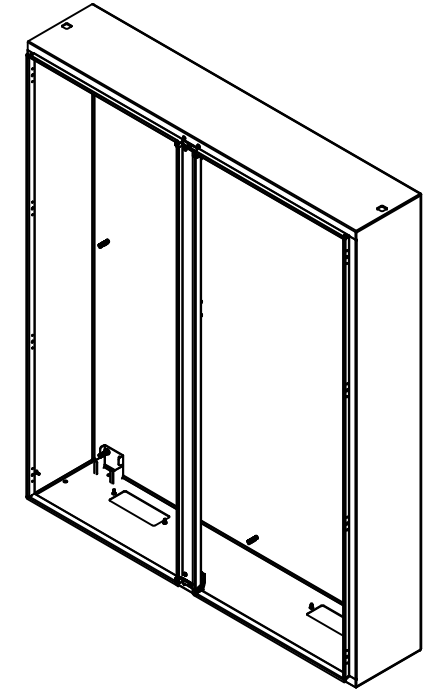

Isometric View



Tél: (450) 979-4373
 Fax: (450) 979-4626
www.exmweb.com

Flatness
Aplatissement

Max 3.0mm

Projection

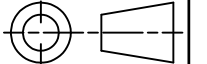

Customer Client	Date
Drawn By Dessiné Par BoxCad: BoxCad	Date 21-Oct-19
Material Matière 12 Ga Stainless Steel 304 (2.5mm)	
Color Couleur Unpainted	Finish Fini Brushed
Description 5412SSDD 72" x 60" x 12" Body	Detail Rev.
Part Number Numéro Pièce 5412SSDD726012B	Rev. 1 0 2

SEE BILL OF MATERIAL ON LAST PAGE

This drawing is confidential and must not be reproduced or used without the consent of EXM

Ce dessin est confidentiel et ne doit pas être reproduit ou utilisé sans le consentement de EXM

STANDARD FEATURES ARE NOT LISTED IN THIS HOLE TABLE

HOLE TABLE - TOP VIEW (CUSTOM FEATURE ONLY)

CUT-OUT	XDIM	YDIM	DESCRIPTION
1	44.895	7.895	Struts CR400 21.500" (Inside)
2	14.895	7.895	Struts CR400 21.500" (Inside)
3	44.895	7.895	STUDS M6 x 10mm (Inside)
4	37.145	7.895	STUDS M6 x 10mm (Inside)
5	52.645	7.895	STUDS M6 x 10mm (Inside)
6	14.895	7.895	STUDS M6 x 10mm (Inside)
7	7.145	7.895	STUDS M6 x 10mm (Inside)
8	22.645	7.895	STUDS M6 x 10mm (Inside)

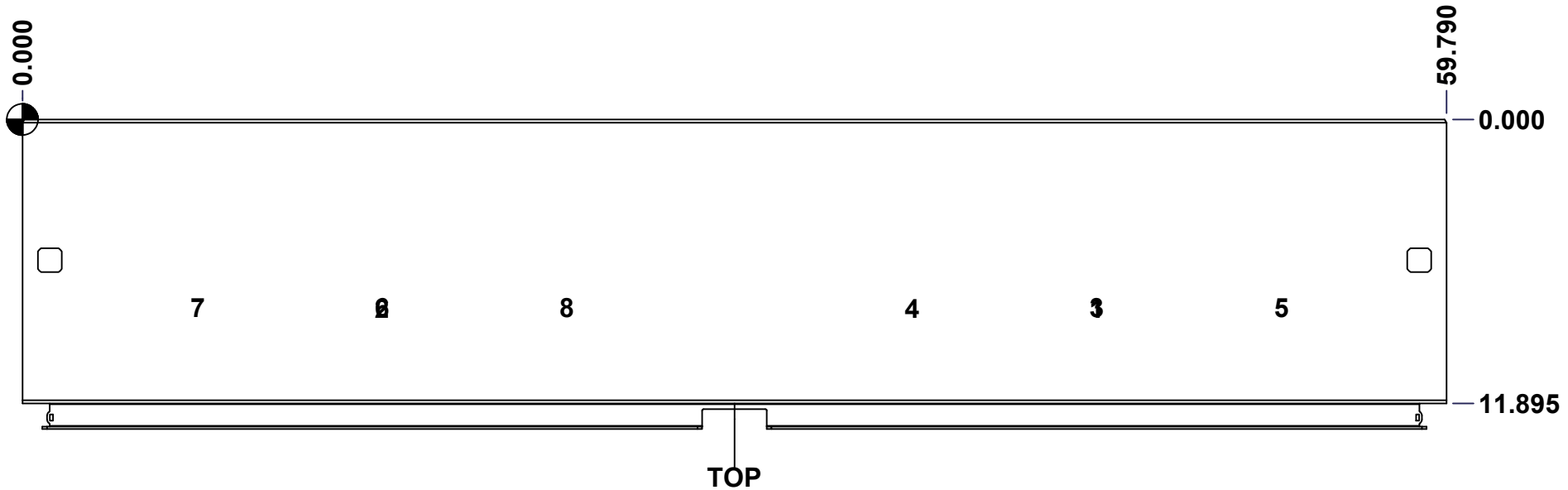

	Description	Status	
	5412SSDD 72" x 60" x 12" Body	Released	
	Part Number Numéro Pièce	Rev.	
	5412SSDD726012B	0	2 / 7

This drawing is confidential and must not be reproduced or used without the consent of EXM

Ce dessin est confidentiel et ne doit pas être reproduit ou utilisé sans le consentement de EXM

STANDARD FEATURES ARE NOT LISTED IN THIS HOLE TABLE			
HOLE TABLE - RIGHT VIEW (CUSTOM FEATURE ONLY)			
CUT-OUT	XDIM	YDIM	DESCRIPTION
1	10.395	3.270	GND STUD M6 x 16mm (Inside)

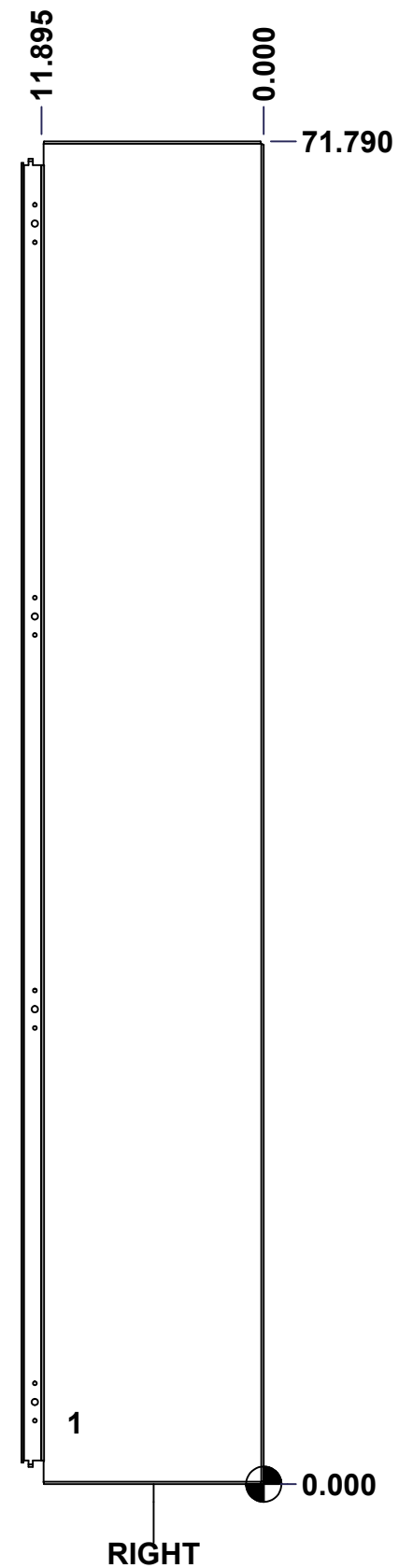

	Description	Status	
	5412SSDD 72" x 60" x 12" Body	Released	
	Part Number Numéro Pièce	Rev.	
	5412SSDD726012B	0	3 / 7

This drawing is confidential and must not be reproduced or used without the consent of EXM

Ce dessin est confidentiel et ne doit pas être reproduit ou utilisé sans le consentement de EXM

STANDARD FEATURES ARE NOT LISTED IN THIS HOLE TABLE			
HOLE TABLE - BOTTOM VIEW (CUSTOM FEATURE ONLY)			
CUT-OUT	XDIM	YDIM	DESCRIPTION
1	7.270	3.395	GP STUD M6 x 16mm (Inside)
2	16.520	3.395	GP STUD M6 x 16mm (Inside)
3	43.270	3.395	GP STUD M6 x 16mm (Inside)
4	52.520	3.395	GP STUD M6 x 16mm (Inside)

5	3.895	0.895	RND Ø0.500
6	0.895	5.895	RND Ø0.500
7	3.895	10.895	RND Ø0.500
8	55.895	0.895	RND Ø0.500
9	58.895	5.895	RND Ø0.500
10	55.895	10.895	RND Ø0.500

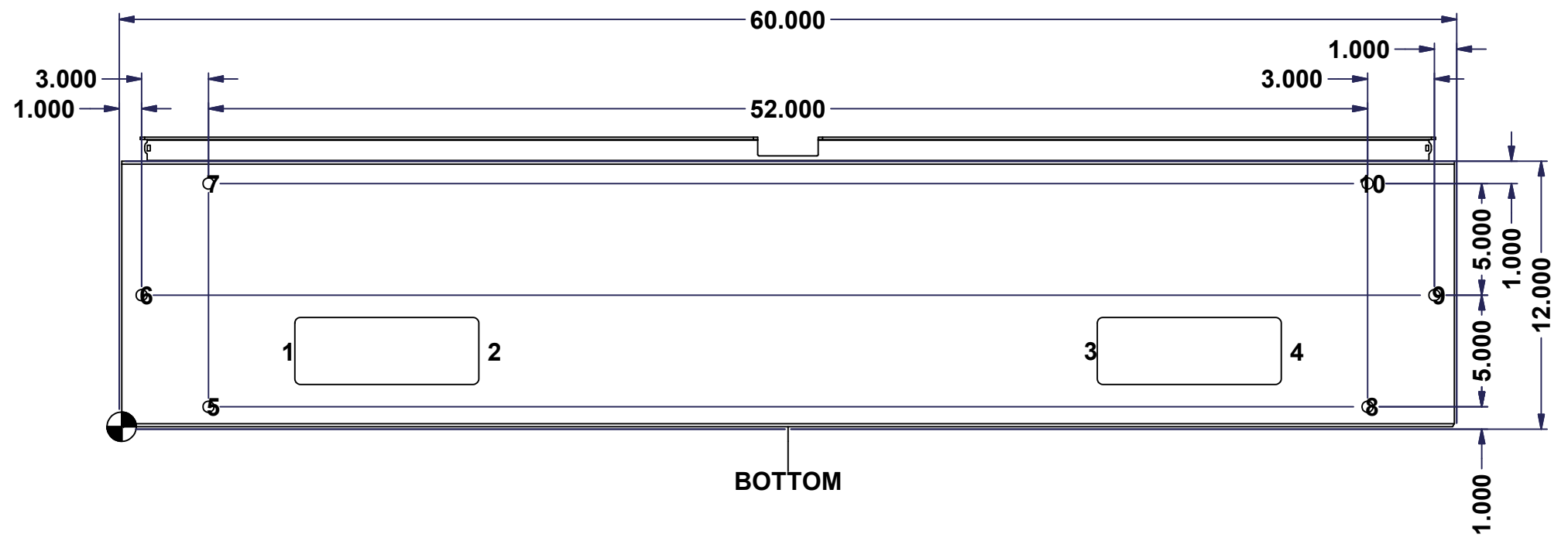

	Description	Status	
	5412SSDD 72" x 60" x 12" Body	Released	
	Part Number Numéro Pièce	Rev.	
	5412SSDD726012B	0	4 / 7

This drawing is confidential and must not be reproduced or used without the consent of EXM

Ce dessin est confidentiel et ne doit pas être reproduit ou utilisé sans le consentement de EXM

STANDARD FEATURES ARE NOT LISTED IN THIS HOLE TABLE			
HOLE TABLE - LEFT VIEW (CUSTOM FEATURE ONLY)			
CUT-OUT	XDIM	YDIM	DESCRIPTION
1	10.395	3.270	GND STUD M6 x 16mm (Inside)

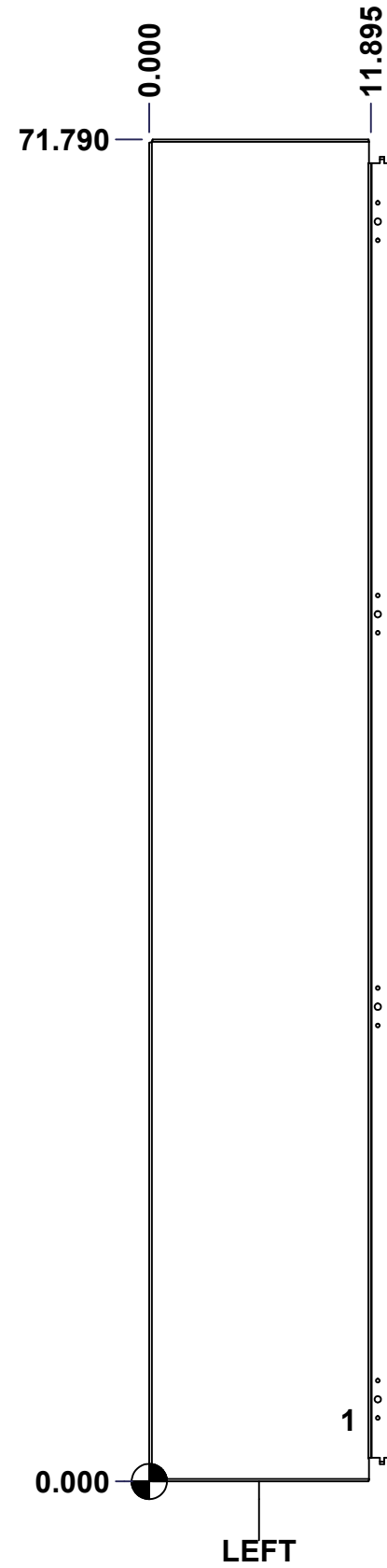

	Description	Status	
	5412SSDD 72" x 60" x 12" Body	Released	
	Part Number Numéro Pièce	Rev.	
	5412SSDD726012B	0	5 / 7

This drawing is confidential and must not be reproduced or used without the consent of EXM

Ce dessin est confidentiel et ne doit pas être reproduit ou utilisé sans le consentement de EXM

STANDARD FEATURES ARE NOT LISTED IN THIS HOLE TABLE

HOLE TABLE - BACK VIEW (CUSTOM FEATURE ONLY)

CUT-OUT	XDIM	YDIM	DESCRIPTION
1	2.770	2.770	IP STUD M10 x 40mm (Inside)
2	57.020	2.770	IP STUD M10 x 40mm (Inside)
3	2.770	35.895	IP STUD M10 x 40mm (Inside)
4	57.020	35.895	IP STUD M10 x 40mm (Inside)
5	2.770	69.020	IP STUD M10 x 40mm (Inside)
6	57.020	69.020	IP STUD M10 x 40mm (Inside)
7	29.895	2.770	IP STUD M10 x 40mm (Inside)
8	29.895	69.020	IP STUD M10 x 40mm (Inside)

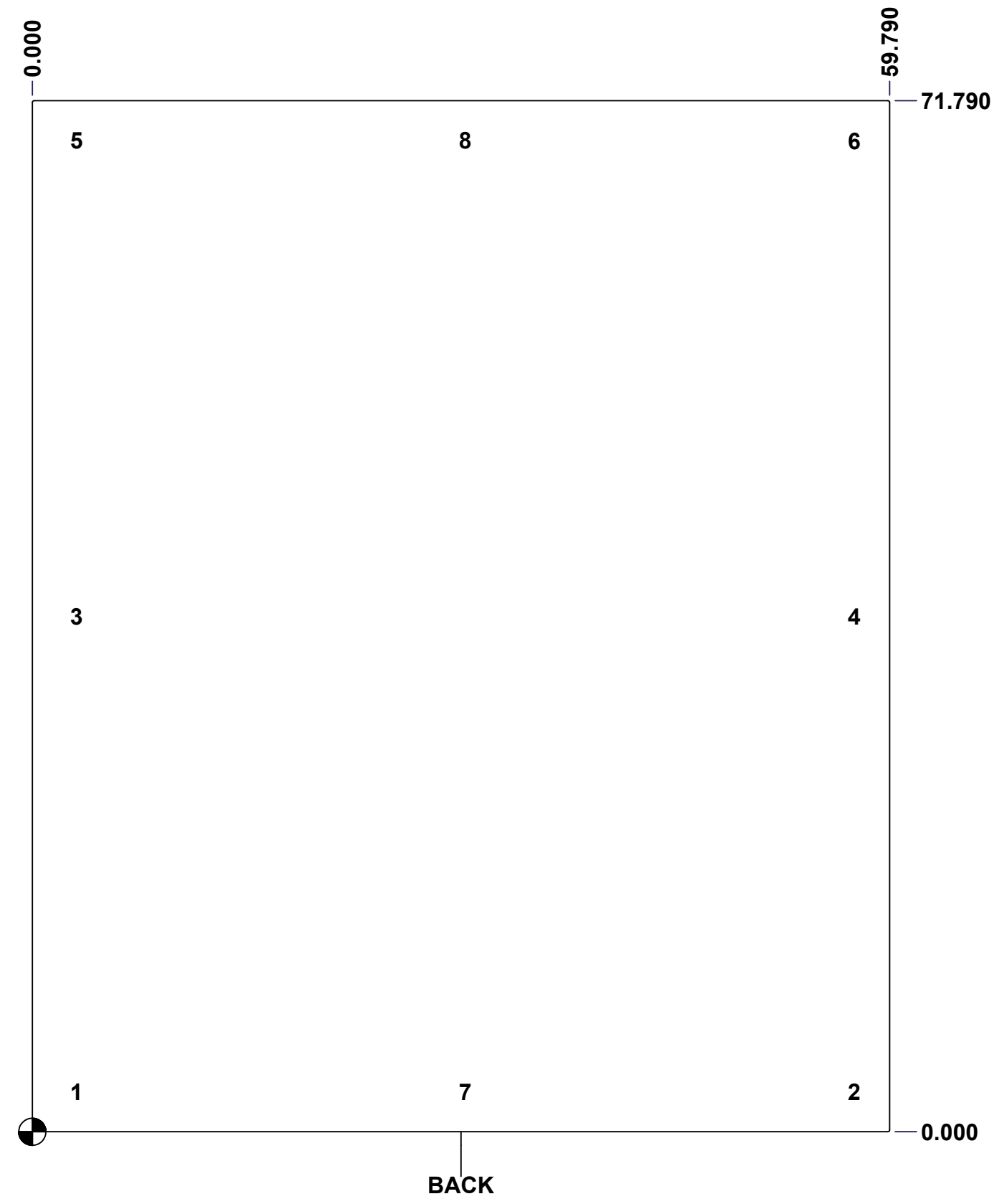

	Description		Status	
	5412SSDD 72" x 60" x 12" Body		Released	
	Part Number Numéro Pièce		Rev.	6
	5412SSDD726012B		0	7

This drawing is confidential and must not be reproduced or used without the consent of EXM

Ce dessin est confidentiel et ne doit pas être reproduit ou utilisé sans le consentement de EXM

STANDARD FEATURES ARE NOT LISTED IN THIS HOLE TABLE			
HOLE TABLE - CENTER VIEW (CUSTOM FEATURE ONLY)			
CUT-OUT	XDIM	YDIM	DESCRIPTION
1	0.748	42.220	INTERLOCK STUD M6 x 16mm (Inside)
2	0.748	44.346	INTERLOCK STUD M6 x 16mm (Inside)
3	2.717	42.220	INTERLOCK STUD M6 x 16mm (Inside)
4	2.717	44.346	INTERLOCK STUD M6 x 16mm (Inside)

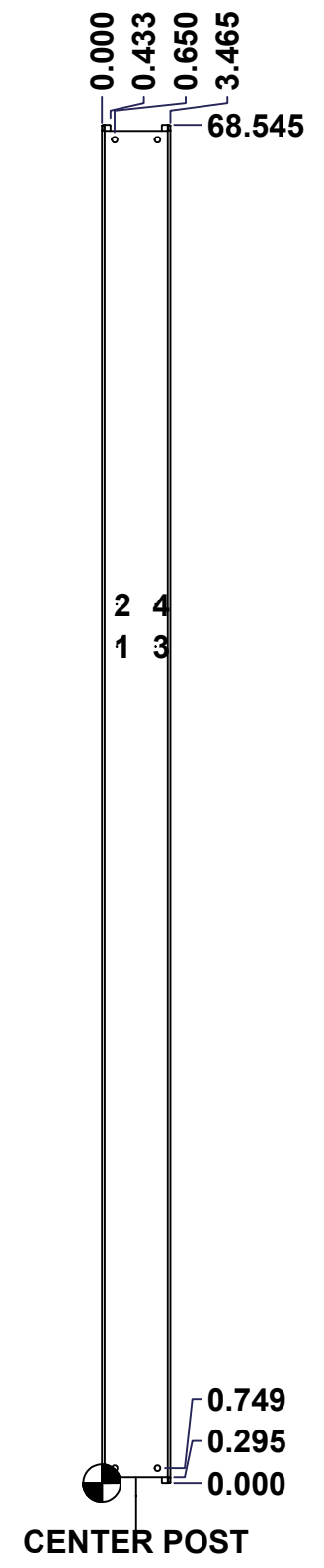

	Description	Status	
	5412SSDD 72" x 60" x 12" Body	Released	
	Part Number Numéro Pièce	Rev.	
	5412SSDD726012B	0	6 7

This drawing is confidential and must not be reproduced or used without the consent of EXM

Ce dessin est confidentiel et ne doit pas être reproduit ou utilisé sans le consentement de EXM

No.	Revisions	Date	By/Par

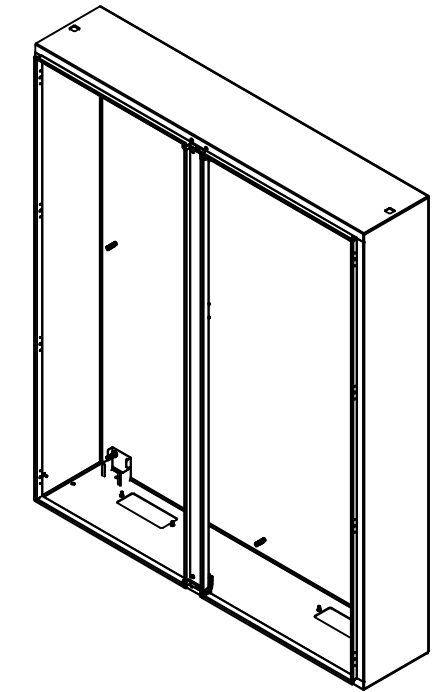

Isometric View



Qty	Part Number	Rev	Description
6	STK-Q-16040	0	Stud M6 x 10mm Stainless Steel
2	STK-Q-16085	0	Ground Stud M6 x 16mm Stainless Steel
6	STK-Q-07220	1	M6 Nylon Insert Lock Nut
4	STK-Q-16095	0	M6 x 16mm Stainless Steel Ground Stud
4	STK-Q-16070	1	Stud M6 x 18mm Stainless steel
1	STK-A-75456	2	Center Post - Stainless Steel Sealing Block with Latch Assembly (Large)
1	5412SSDD726012CP-P	0	5412SSDD 72" Center Post Part
2	STK-Q-07320	0	Flange Lock Nut M10
2	STK-Q-07618	1	5500 Series Inner Panel Support Bracket
8	STK-Q-16120	0	Stud M10 x 40mm Stainless Steel
1	5412SSDD726012BT-P	0	5412SSDD 60" x 12" Bottom Part
1	5412SSDD726012T-P	0	5412SSDD 60" x 12" Top Part
1	5412SSDD726012RS-P	0	5412SSDD 72" x 60" Right Part
1	5412SSDD726012LS-P	0	5412SSDD 72" x 60" Left Part
1	5412SSDD726012B-P	0	5412SSDD 72" x 60" Back Part
2	CR400SS_21.5	0	Commercial Roll Stainless Steel (21.5in long)
Qty	Part Number	Rev	Description
Parts List			

Tél: (450) 979-4373 Fax: (450) 979-4626 www.exmweb.com	Flatness Aplatissement
	Max 3.0mm
Projection	
Customer Client	Date
Drawn By Dessiné Par	Date 21-Oct-19
Material Matière	12 Ga Stainless Steel 304 (2.5mm)
Color Couleur	Unpainted
Finish Fini	Brushed
Description	Detail Rev.
5412SSDD 72" x 60" x 12" Body	
Part Number Numéro Pièce	Rev. 2
5412SSDD726012B	0

This drawing is confidential and must not be reproduced or used without the consent of EXM

Ce dessin est confidentiel et ne doit pas être reproduit ou utilisé sans le consentement de EXM



TOP



BACK

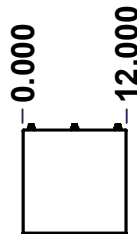

LEFT



FRONT



RIGHT

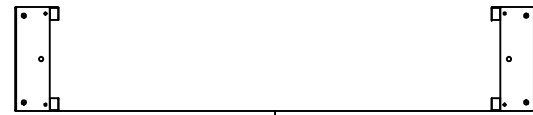

BOTTOM

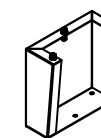

Isometric View

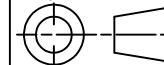

No.	Revisions	Date	By/Par

 Tél: (450) 979-4373 Fax: (450) 979-4626 www.exmweb.com		Flatness Aplatissement Max 3.0mm Projection 
Customer Client	Date	
Drawn By Dessiné Par	BoxCad: BoxCad	Date 21-Oct-19
Material Matière	12 Ga Stainless Steel 304 (2.5mm)	
Color Couleur	Unpainted	Finish Fini Brushed
Description	Detail Rev.	
885 MFHD 12" x 12" Mounting Feet		
Part Number Numéro Pièce	Rev.	1
5412SSDD726012MF	0	4

SEE BILL OF MATERIAL ON LAST PAGE

This drawing is confidential and must not be reproduced or used without the consent of EXM

Ce dessin est confidentiel et ne doit pas être reproduit ou utilisé sans le consentement de EXM

No.	Revisions	Date	By/Par

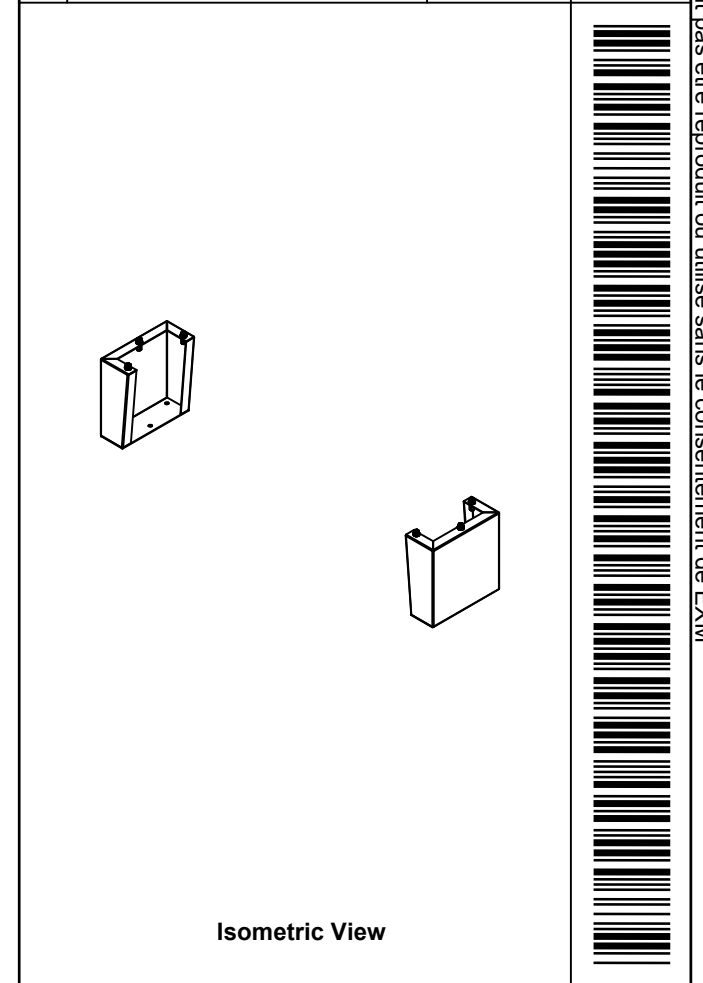

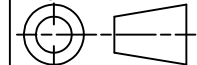
 Tél: (450) 979-4373 Fax: (450) 979-4626 www.exmweb.com		Flatness Aplatissement Max 3.0mm Projection 
Customer Client	Date	
Drawn By Dessiné Par	BoxCad: BoxCad	Date 21-Oct-19
Material Matière	12 Ga Stainless Steel 304 (2.5mm)	
Color Couleur	Unpainted	Finish Fini Brushed
Description 885 MFHD 12" x 12" Mounting Feet		Detail Rev.
Part Number Numéro Pièce	5412SSDD726012MF	Rev. 0

Qty	Part Name	Rev	Description
6	RIVET_NUT_SS_M10_FH _CE	0	Stainless Steel Rivet Nut M10 (Low Profile Close End)
1	5412SSDD726012MFR-P	0	885 MFHD 12" x 12" Right Mounting Feet Part
1	5412SSDD726012MFL-P	0	885 MFHD 12" x 12" Left Mounting Feet Part
1	STK-K-11610	2	885 MFSS Accessory Kit
Parts List			

This drawing is confidential and must not be reproduced or used without the consent of EXM

Ce dessin est confidentiel et ne doit pas être reproduit ou utilisé sans le consentement de EXM

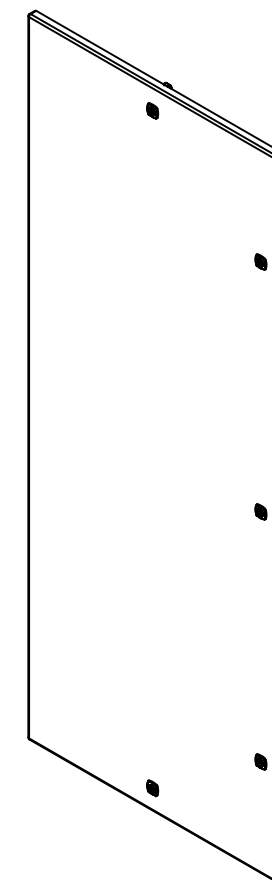
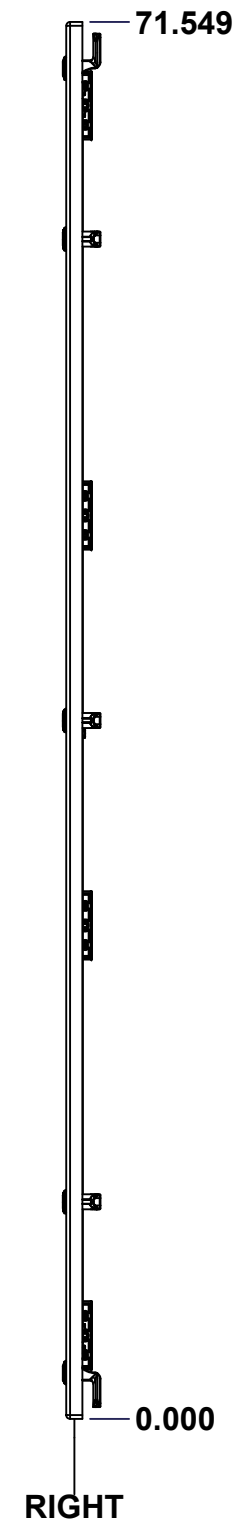
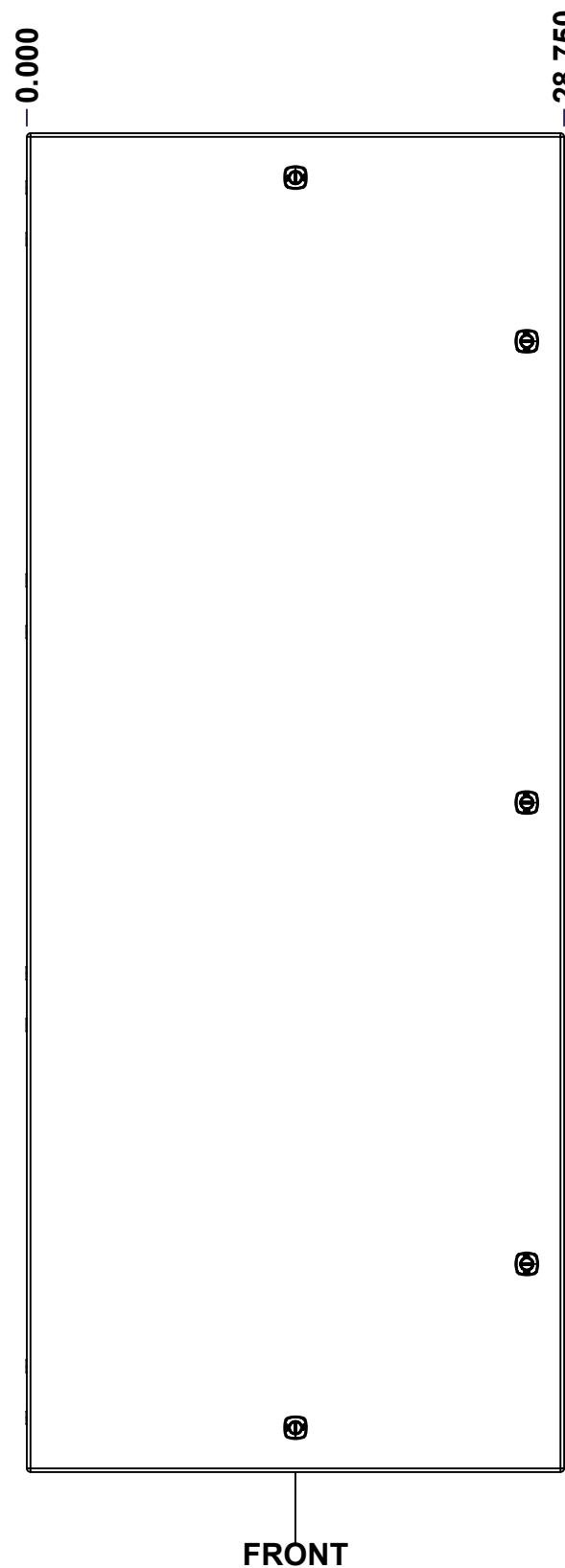
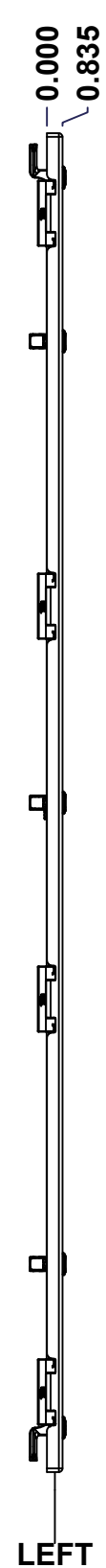
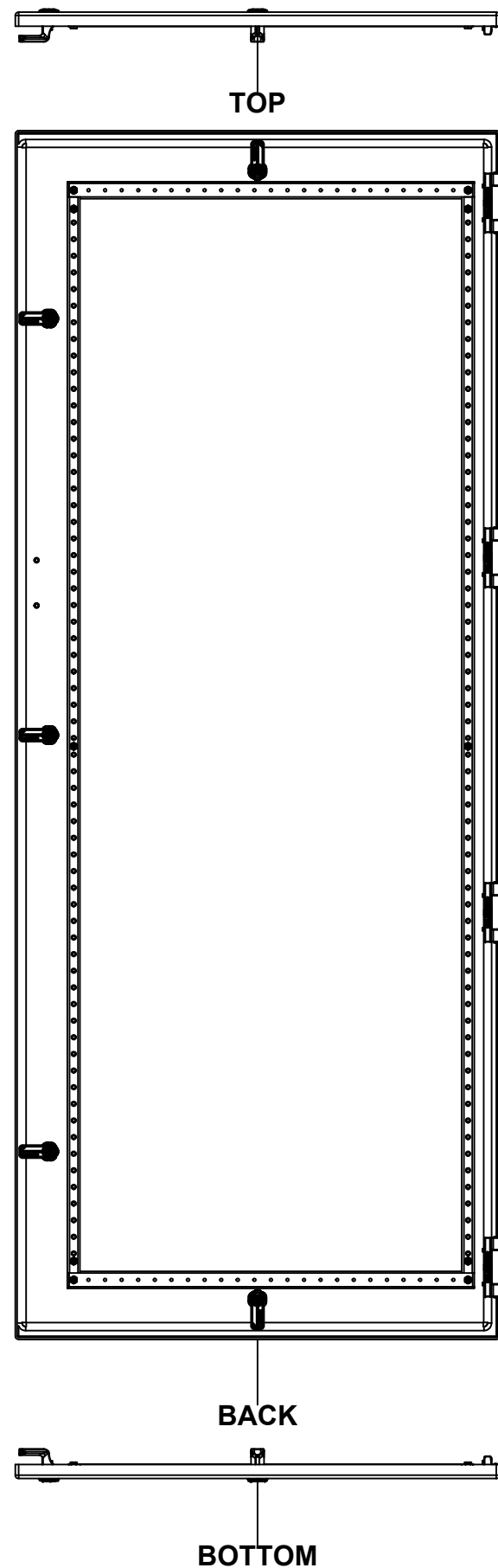

Isometric View

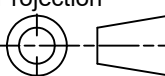

No.	Revisions	Date	By/Par

 Tél: (450) 979-4373 Fax: (450) 979-4626 www.exmweb.com		Flatness Aplatissement Max 3.0mm Projection 
Customer Client		Date
Drawn By Dessiné Par	BoxCad: BoxCad	Date 21-Oct-19
Material Matière	12 Ga Stainless Steel 304 (2.5mm)	
Color Couleur	Unpainted	Finish Fini Brushed
Description	Detail Rev.	
Part Number Numéro Pièce	Rev. 0	1 / 3

SEE BILL OF MATERIAL ON LAST PAGE

5412SSDD726012LD

This drawing is confidential and must not be reproduced or used without the consent of EXM

Ce dessin est confidentiel et ne doit pas être reproduit ou utilisé sans le consentement de EXM

STANDARD FEATURES ARE NOT LISTED IN THIS HOLE TABLE			
HOLE TABLE - FRONT VIEW (CUSTOM FEATURE ONLY)			
CUT-OUT	XDIM	YDIM	DESCRIPTION
1	1.875	3.524	STUD M6 x 18mm (Inside)
2	1.875	35.109	STUD M6 x 18mm (Inside)
3	1.875	68.024	STUD M6 x 18mm (Inside)
4	1.875	4.636	STUD M6 x 18mm (Inside)
5	1.875	66.912	STUD M6 x 18mm (Inside)
6	25.282	3.524	STUD M6 x 18mm (Inside)
7	25.282	35.109	STUD M6 x 18mm (Inside)
8	25.282	68.024	STUD M6 x 18mm (Inside)
9	25.282	4.636	STUD M6 x 18mm (Inside)
10	25.282	66.912	STUD M6 x 18mm (Inside)

11	26.750	60.430	LOCK 889 SCQ4-SLSS6 @ 0.0°
12	26.750	35.774	LOCK 889 SCQ4-SLSS6 @ 0.0°
13	26.750	11.118	LOCK 889 SCQ4-SLSS6 @ 0.0°
14	14.375	69.180	LOCK 889 SCQ4-SLSS6 @ 90.0°
15	14.375	2.368	LOCK 889 SCQ4-SLSS6 @ 270.0°
16	27.489	43.445	STUDS M6 x 18mm (Inside)
17	27.489	46.123	STUDS M6 x 18mm (Inside)

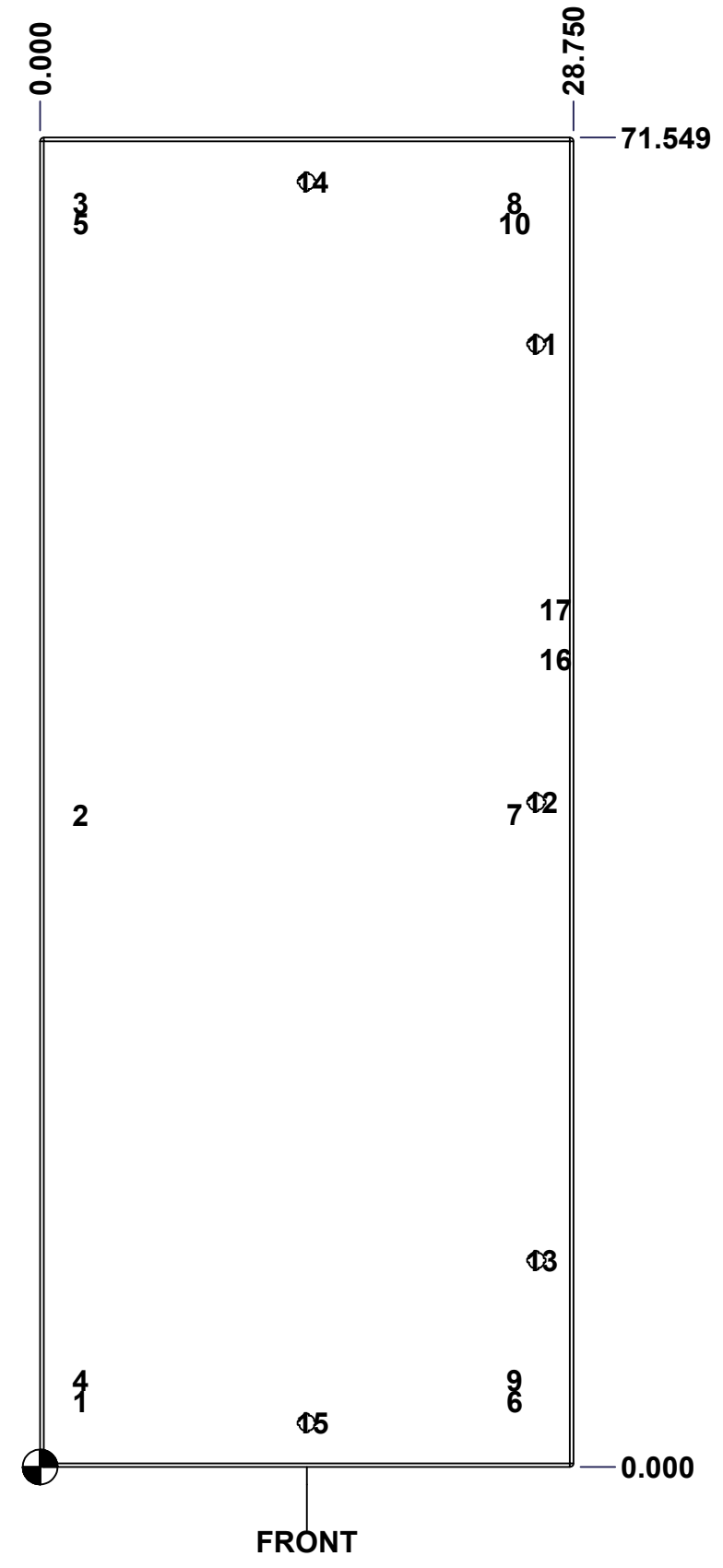



	Description	Status
	5412SSDD 72" x 60" Slave Door	(NULL)
	Part Number Numéro Pièce	Rev.
	5412SSDD726012LD	0
		2
		3

This drawing is confidential and must not be reproduced or used without the consent of EXM

Ce dessin est confidentiel et ne doit pas être reproduit ou utilisé sans le consentement de EXM

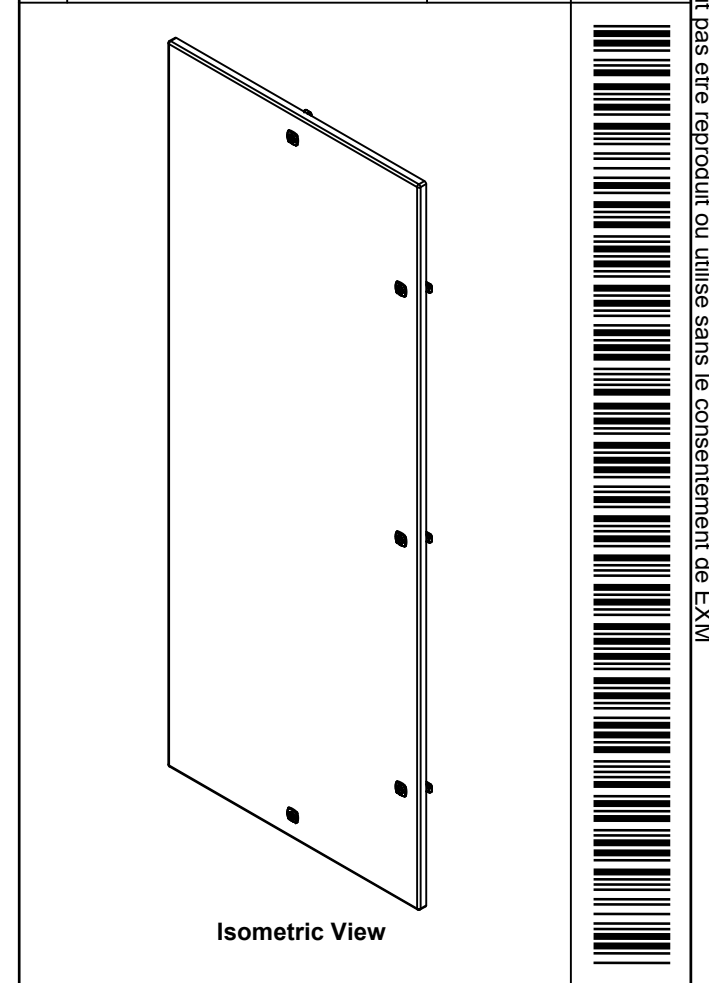
No.	Revisions	Date	By/Par

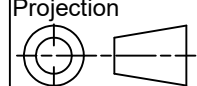

 Tél: (450) 979-4373 Fax: (450) 979-4626 www.exmweb.com		Flatness Aplatissement Max 3.0mm Projection 
Customer Client	Date	
Drawn By Dessiné Par	BoxCad: BoxCad	Date 21-Oct-19
Material Matière	12 Ga Stainless Steel 304 (2.5mm)	
Color Couleur	Unpainted	Finish Fini Brushed
Description		Detail Rev.
5412SSDD 72" x 60" Slave Door		
Part Number Numéro Pièce	Rev.	3
5412SSDD726012LD	0	3

Qty	Part Name	Rev	Description
1	5412SSDD726012DG	0	5412SSDD 72" x 60" Door Gasket
1	5412SSDD726012DS1	0	5412SSDD 72" x 60" Door Stiffener
12	STK-Q-16070	1	Stud M6 x 18mm Stainless Steel
1	5412SSDD726012LD-P	0	5412SSDD 72" x 60" Slave Door Part
4	STK-K-09870	7	Cabinet Hinge with Captive Pins
5	889 SCQ4-SLSS6	0	9412 SS 1/4 Turn Lock
Parts List			

This drawing is confidential and must not be reproduced or used without the consent of EXM

Ce dessin est confidentiel et ne doit pas être reproduit ou utilisé sans le consentement de EXM

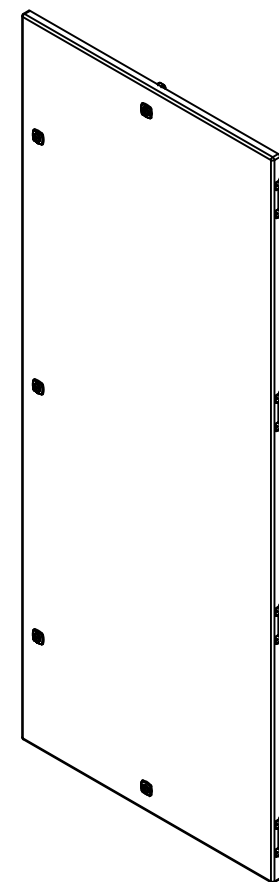
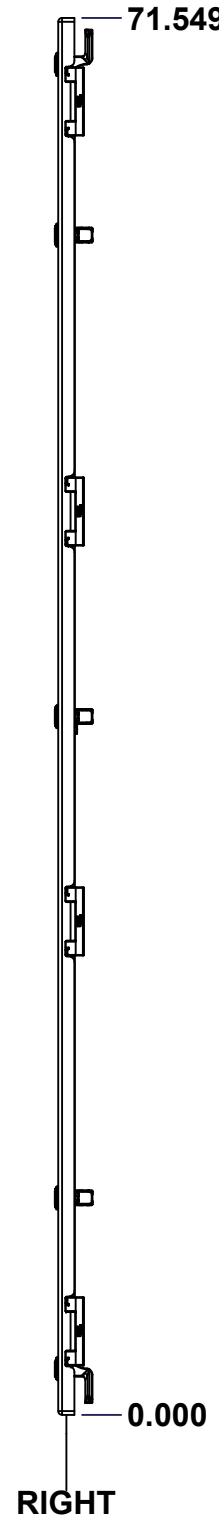
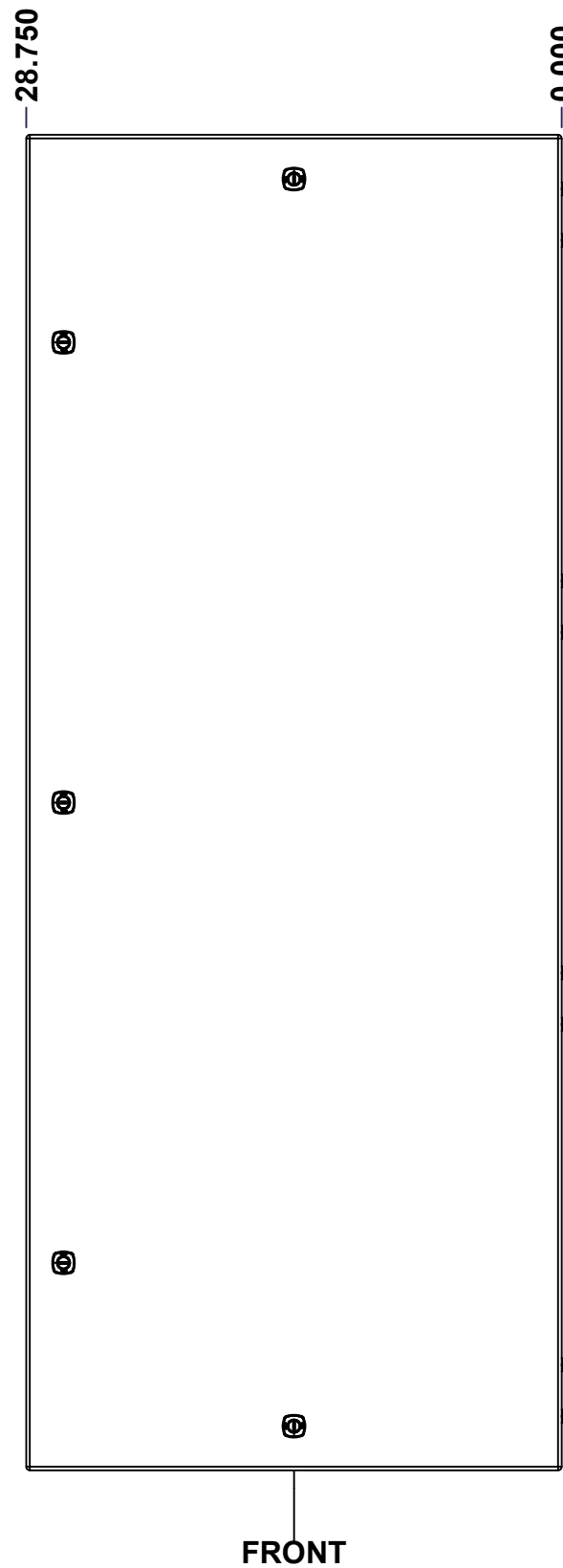
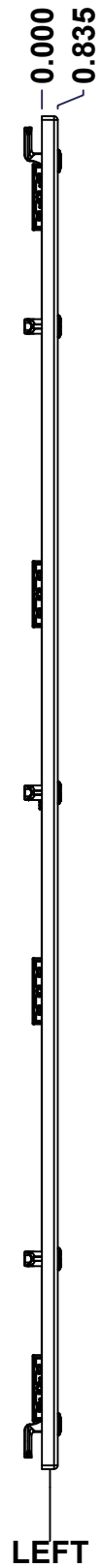
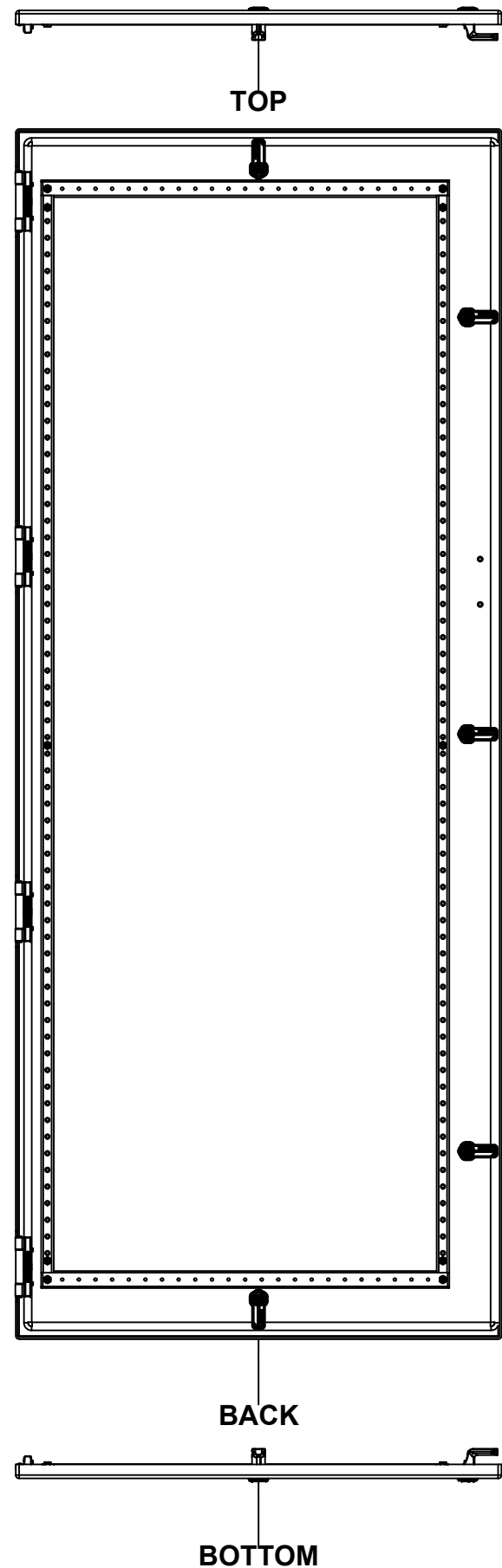

Isometric View



No.	Revisions	Date	By/Par

Tél: (450) 979-4373 Fax: (450) 979-4626 www.exmweb.com		Flatness Aplatissement Max 3.0mm Projection
Customer Client	BoxCad: BoxCad	Date 21-Oct-19
Material Matière 12 Ga Stainless Steel 304 (2.5mm)		
Color Couleur Unpainted	Finish Fini Brushed	
Description 5412SSDD 72" x 60" Master Door		Detail Rev.
Part Number Numéro Pièce 5412SSDD726012FD	Rev. 0	1/3

SEE BILL OF MATERIAL ON LAST PAGE

This drawing is confidential and must not be reproduced or used without the consent of EXM

Ce dessin est confidentiel et ne doit pas être reproduit ou utilisé sans le consentement de EXM

STANDARD FEATURES ARE NOT LISTED IN THIS HOLE TABLE

HOLE TABLE - FRONT VIEW (CUSTOM FEATURE ONLY)

CUT-OUT	XDIM	YDIM	DESCRIPTION
1	1.875	3.524	STUD M6 x 18mm (Inside)
2	1.875	35.109	STUD M6 x 18mm (Inside)
3	1.875	68.024	STUD M6 x 18mm (Inside)
4	1.875	4.636	STUD M6 x 18mm (Inside)
5	1.875	66.912	STUD M6 x 18mm (Inside)
6	25.282	3.524	STUD M6 x 18mm (Inside)
7	25.282	35.109	STUD M6 x 18mm (Inside)
8	25.282	68.024	STUD M6 x 18mm (Inside)
9	25.282	4.636	STUD M6 x 18mm (Inside)
10	25.282	66.912	STUD M6 x 18mm (Inside)
-----	-----	-----	-----
11	26.750	60.430	LOCK 889 SCQ4-SLSS6 @ 180.0°
12	26.750	35.774	LOCK 889 SCQ4-SLSS6 @ 180.0°
13	26.750	11.118	LOCK 889 SCQ4-SLSS6 @ 180.0°
14	14.375	69.180	LOCK 889 SCQ4-SLSS6 @ 90.0°
15	14.375	2.368	LOCK 889 SCQ4-SLSS6 @ 270.0°
16	27.489	43.445	STUDS M6 x 18mm (Inside)
17	27.489	46.123	STUDS M6 x 18mm (Inside)

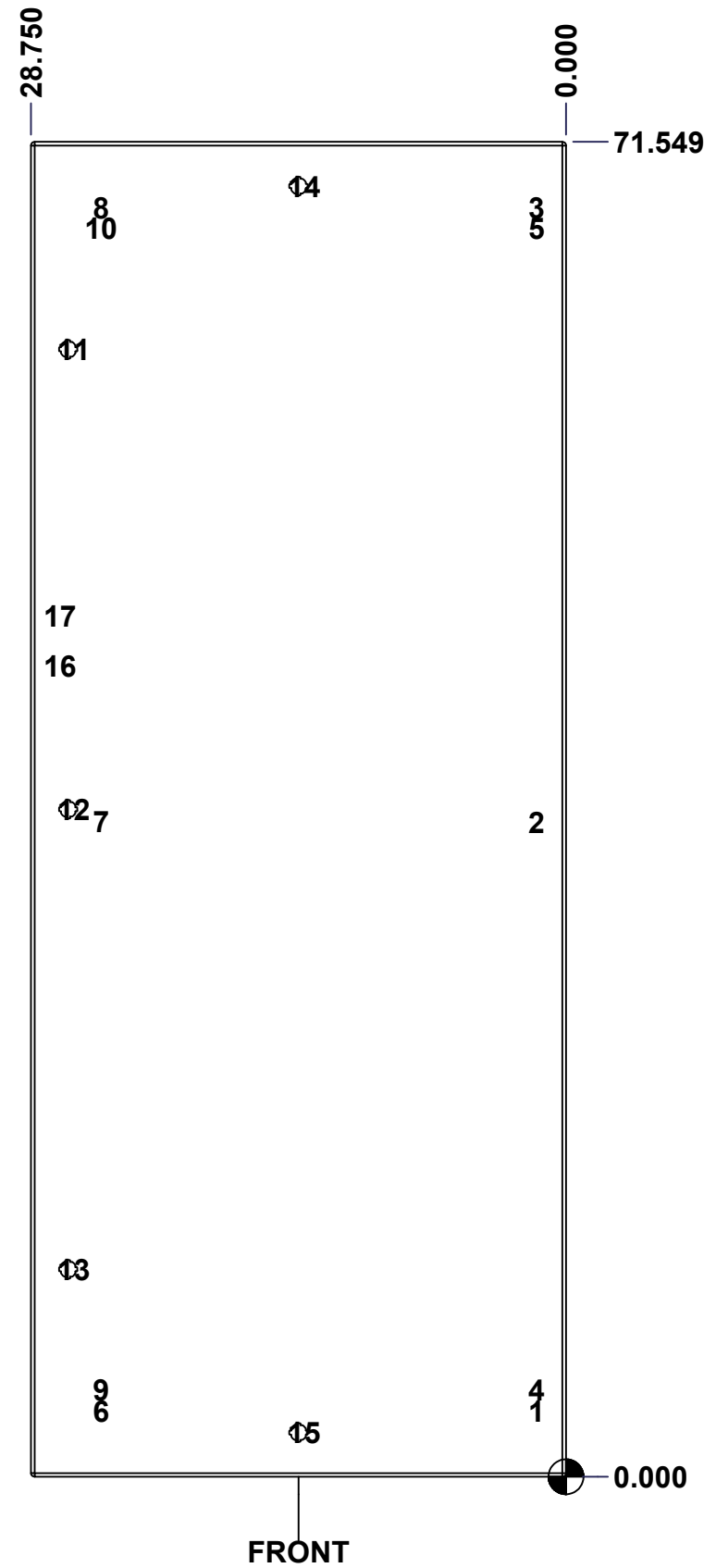



	Description	Status
	5412SSDD 72" x 60" Master Door	(NULL)
	Part Number Numéro Pièce	Rev.
	5412SSDD726012FD	0
		2
		3

This drawing is confidential and must not be reproduced or used without the consent of EXM

Ce dessin est confidentiel et ne doit pas être reproduit ou utilisé sans le consentement de EXM

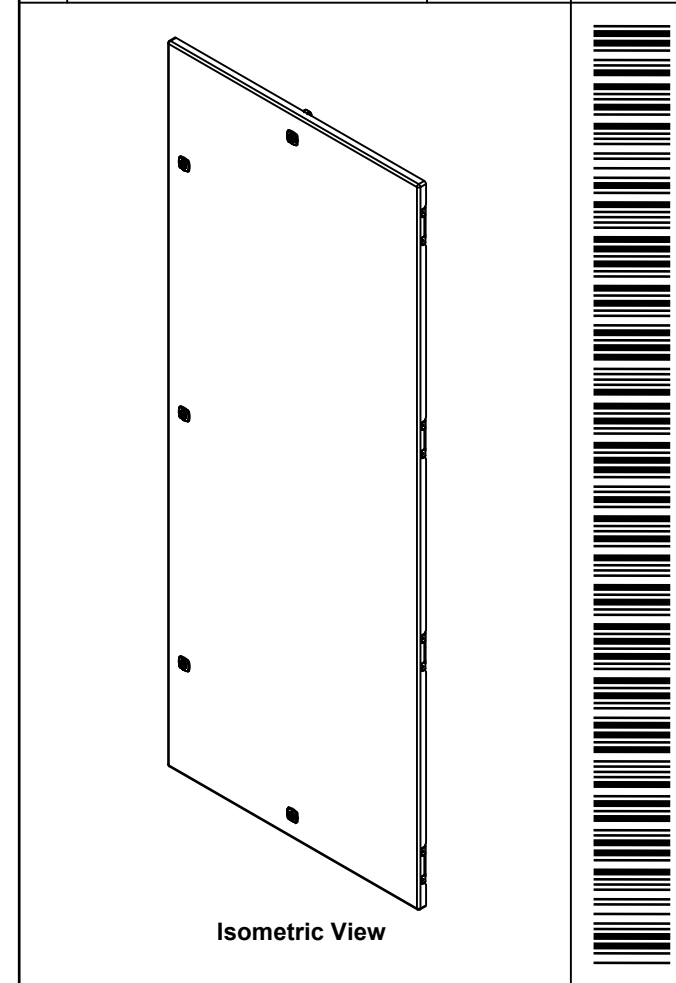
No.	Revisions	Date	By/Par

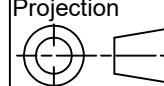

 Tél: (450) 979-4373 Fax: (450) 979-4626 www.exmweb.com		Flatness Aplatissement Max 3.0mm Projection 
Customer Client	Date	
Drawn By Dessiné Par	BoxCad: BoxCad	Date 21-Oct-19
Material Matière	12 Ga Stainless Steel 304 (2.5mm)	
Color Couleur	Unpainted	Finish Fini Brushed
Description		Detail Rev.
5412SSDD 72" x 60" Master Door		
Part Number Numéro Pièce	Rev.	3
5412SSDD726012FD	0	3

Qty	Part Name	Rev	Description
1	5412SSDD726012DG	0	5412SSDD 72" x 60" Door Gasket
1	5412SSDD726012DS1	0	5412SSDD 72" x 60" Door Stiffener
12	STK-Q-16070	1	Stud M6 x 18mm Stainless Steel
1	5412SSDD726012FD-P	0	5412SSDD 72" x 60" Master Door Part
4	STK-K-09870	7	Cabinet Hinge with Captive Pins
5	889 SCQ4-SLSS6	0	9412 SS 1/4 Turn Lock
Parts List			

This drawing is confidential and must not be reproduced or used without the consent of EXM

Ce dessin est confidentiel et ne doit pas être reproduit ou utilisé sans le consentement de EXM

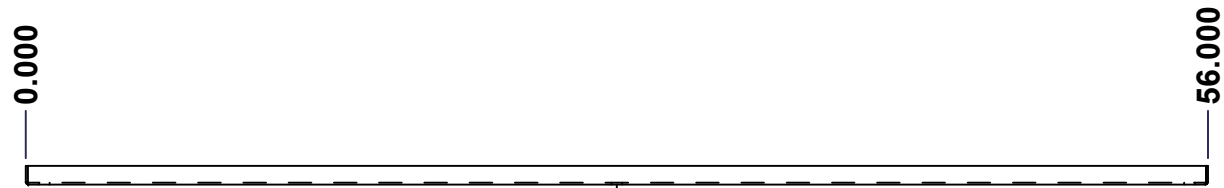

TOP

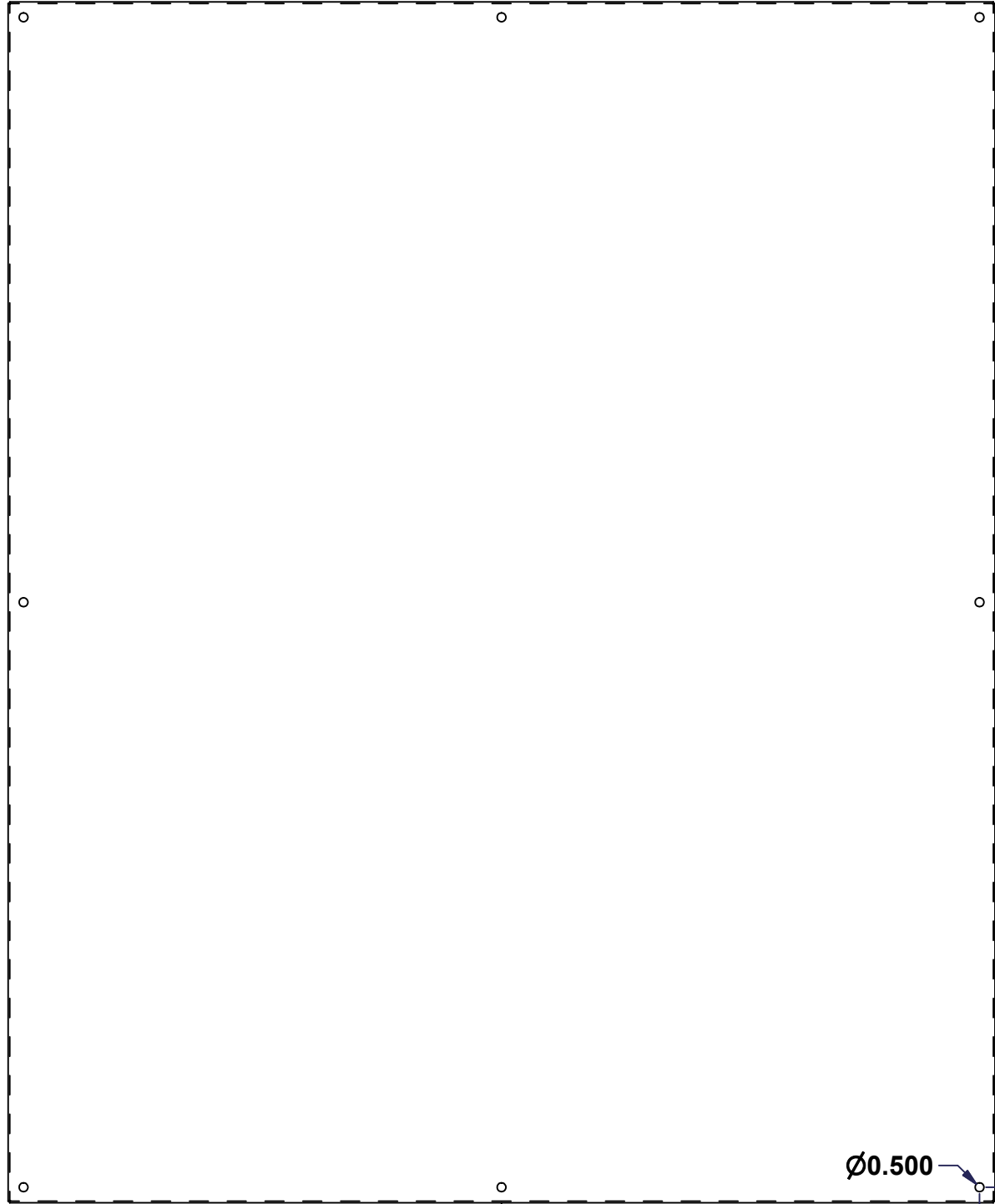

FRONT

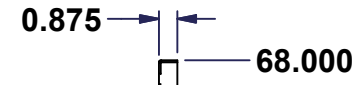

RIGHT

No.	Revisions	Date	By/Par

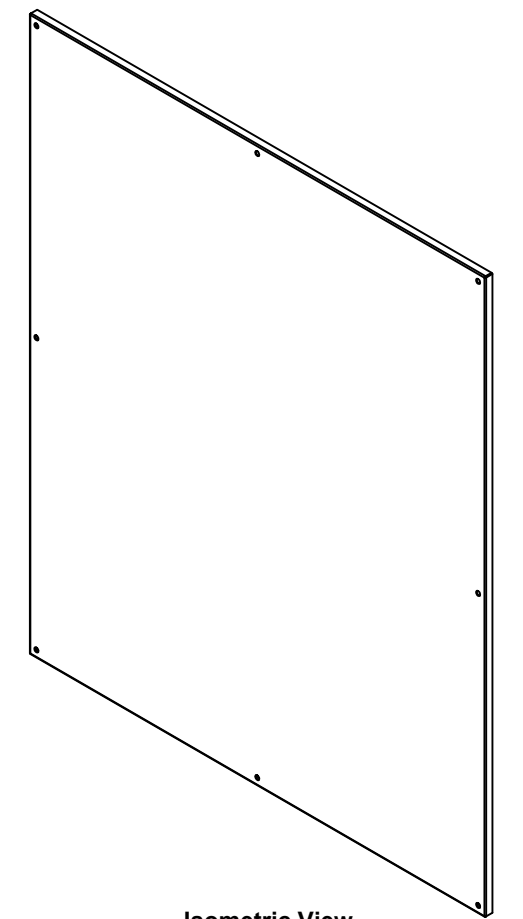

Isometric View



Tél: (450) 979-4373
 Fax: (450) 979-4626
 www.exmweb.com

Flatness
 Aplatissement
 Max 3.0mm
 Projection

Customer Client	Date
Drawn By / Dessiné Par: BoxCad	Date: 04/11/2009

Material / Matière: 12 Ga Galvanized (2.5mm)

Color / Couleur: Unpainted	Finish / Fini: Unpainted
----------------------------	--------------------------

Description: 885 SP7260G Inner Panel

Part Number / Numéro Pièce: 885SP7260G	Rev. 0	1	2
--	--------	---	---

SEE BILL OF MATERIAL ON LAST PAGE

This drawing is confidential and must not be reproduced or used without the consent of EXM

Ce dessin est confidentiel et ne doit pas être reproduit ou utilisé sans le consentement de EXM

No.	Revisions	Date	By/Par

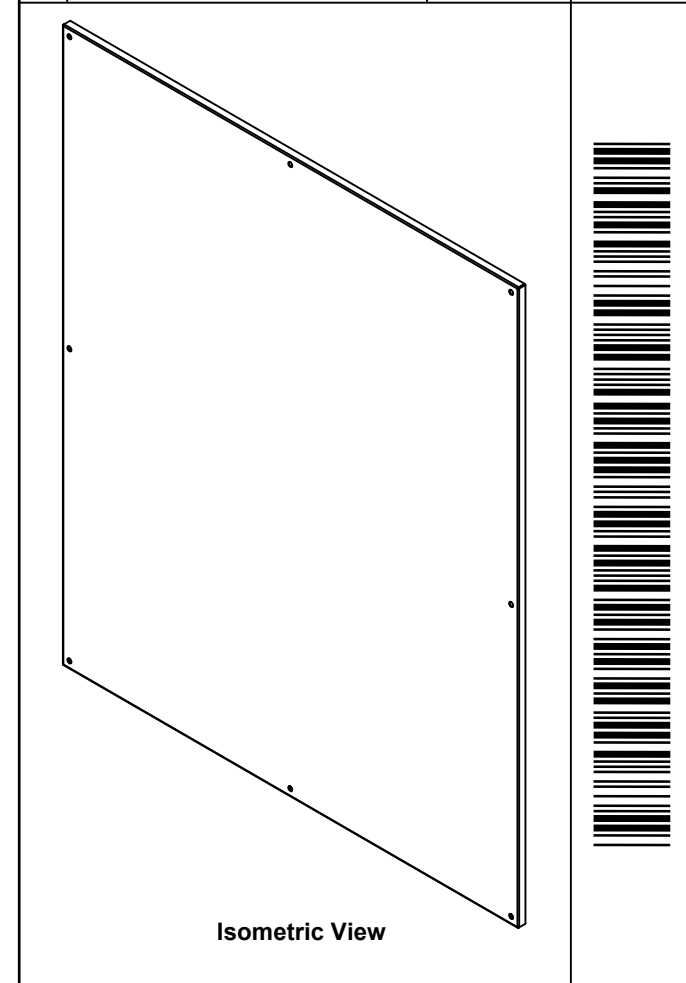

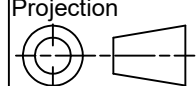
 Tél: (450) 979-4373 Fax: (450) 979-4626 www.exmweb.com		Flatness Aplatissement Max 3.0mm
Projection 		Date
Customer Client		Date 04/11/2009
Drawn By Dessiné Par BoxCad		Date
Material Matière 12 Ga Galvanized (2.5mm)		
Color Couleur Unpainted		Finish Fini Unpainted
Description 885 SP7260G Inner Panel		Detail Rev.
Part Number Numéro Pièce 885SP7260G		Rev. 2 0

Qty	Part Number	Rev	Description
1	885SP7260G-P	0	885 SP7260G Inner Panel Part
Parts List			