

This drawing is confidential and must not be reproduced or used without the consent of EXM

Ce dessin est confidentiel et ne doit pas être reproduit ou utilisé sans le consentement de EXM

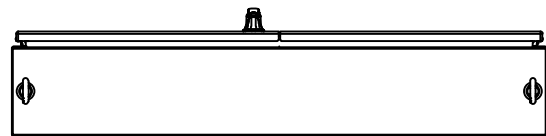

TOP

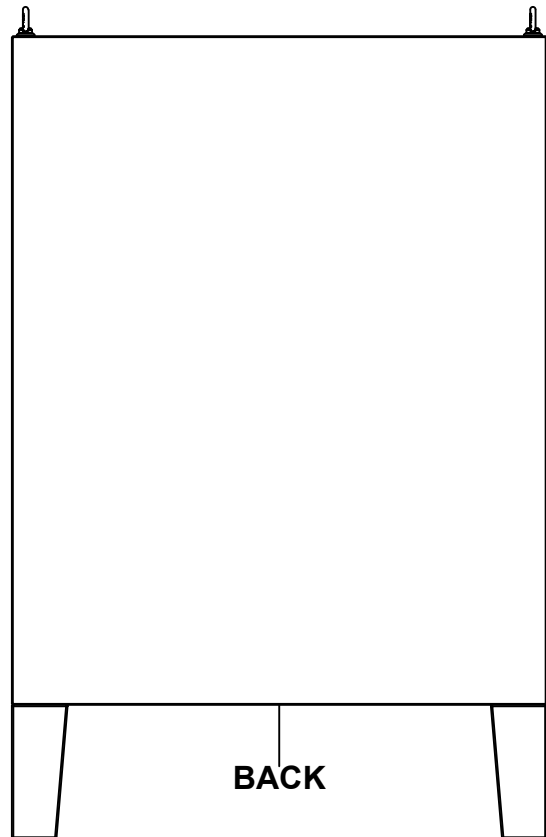

BACK

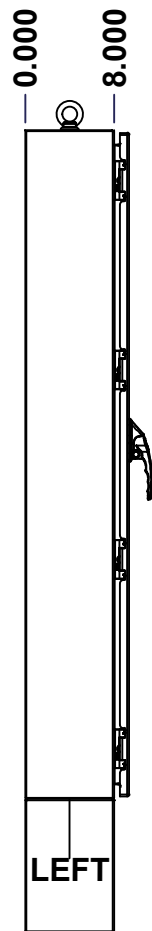

LEFT

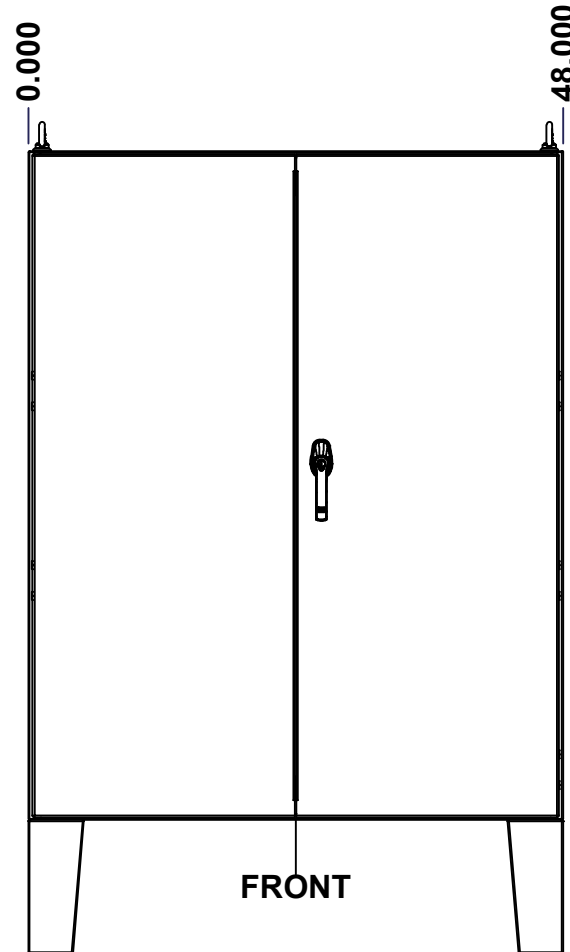

FRONT

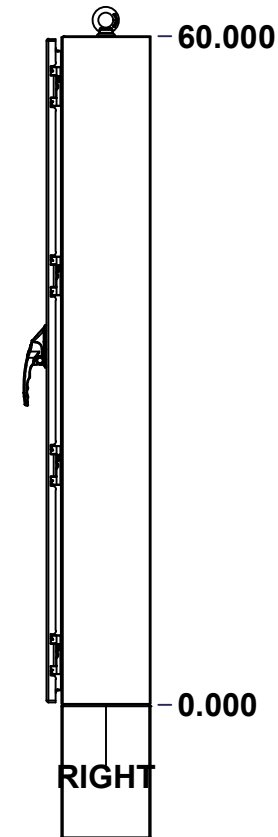

RIGHT

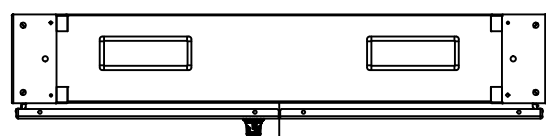

BOTTOM

| No. | Revisions | Date | By/Par |
|-----|-----------|------|--------|
| | | | |
| | | | |
| | | | |
| | | | |

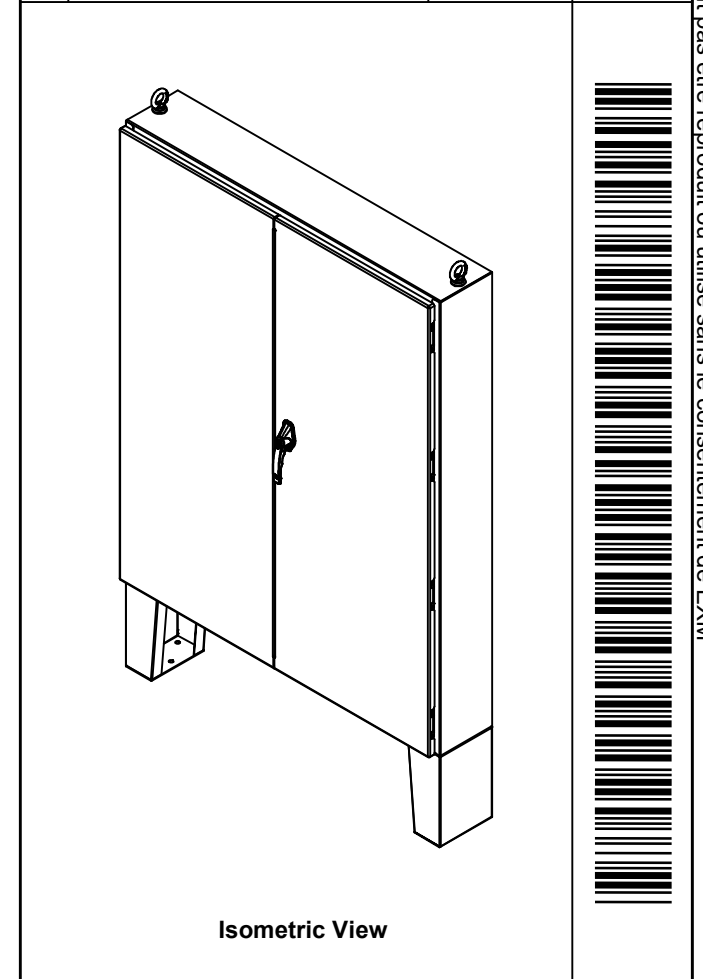

Isometric View

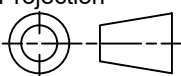
| | | |
|----------------------------------------------------------------------------------------------------------------------------------------------------------------------------------------|-------------------------------------------|-----------------------------------------------------------------------------------------------------------------------------------------------|
|  Tél: (450) 979-4373 Fax: (450) 979-4626 www.exmweb.com | | Flatness Aplatissement Max 3.0mm Projection  |
| Customer Client | Date | |
| Drawn By Dessiné Par | BoxCad: BoxCad | Date 08-Sep-14 |
| Material Matière | 12 Ga Cold Rolled A1008 CS Type B (2.5mm) | |
| Color Couleur | Asa-61 Grey | Finish Fini Smooth |
| Description | Detail Rev. | |
| 5500DDS 60" x 48" x 8" Assembly | | |
| Part Number Numéro Pièce | Rev. | 1 |
| 5500DDS604808 | 0 | 17 |

SEE BILL OF MATERIAL ON LAST PAGE

This drawing is confidential and must not be reproduced or used without the consent of EXM

Ce dessin est confidentiel et ne doit pas être reproduit ou utilisé sans le consentement de EXM

| NOTE | |
|------|-----------------------------------------------|
| ITEM | DESCRIPTION |
| 1 | NEMA 12/13 Enclosure |
| 2 | C/W Standard ground studs on box and cover |
| 3 | C/W Standard door stiffener |
| 4 | C/W Standard inner panel (Included) |
| 5 | C/W Standard inner panel mounting studs |
| 6 | C/W Eyebolts |
| 7 | C/W Mounting feet sold separately (Installed) |
| 8 | C/W Struts installed (Included) |

| No. | Revisions | Date | By/Par |
|-----|-----------|------|--------|
| | | | |
| | | | |
| | | | |
| | | | |
| | | | |
| | | | |

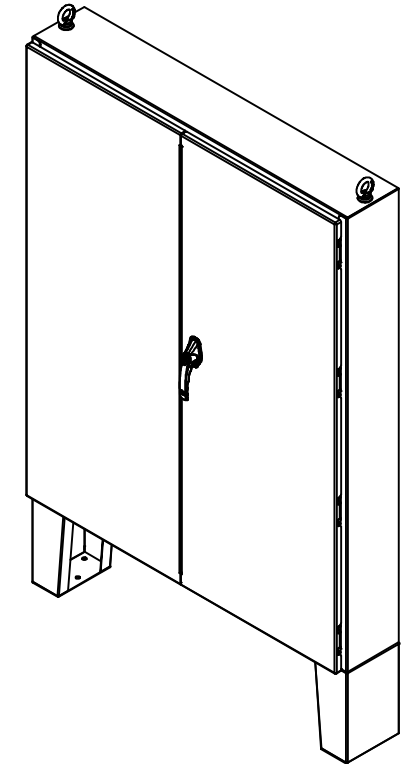

Isometric View



Tél: (450) 979-4373
Fax: (450) 979-4626
www.exmweb.com

Flatness
Aplatissement
Max 3.0mm
Projection



| PACKING | | |
|-----------------------|-----|------------------------------------------------|
| ITEM | QTY | DESCRIPTION |
| Cardboard sleeve | 2 | Top and Bottom |
| Cardboard strip | 2 | Between back of enclosure and inner panel |
| Plastic bag | 1 | To protect cover surface and inside gasket |
| Cardboard corner | 4 | To reinforced for the plastic strap tightening |
| Plastic strap - Black | 2 | To Squeeze 2 cardboard sleeve together |
| Packaging label | 3 | White label with PN |
| Plastic strap- Green | 2 | To secure the enclosure to the wood pallet |
| Wood Pallet | 1 | 2" deeper and 3" larger than enclosure size |

| | | | |
|------------|-----------------|-----|---------------------------------------------------------|
| 1 | 5500DDS604808MF | 0 | 885 MFHD 12" x 8" Mounting Feet |
| 1 | 880EB14 | 2 | Eye Bolt M14 (Pack of 2) |
| 8 | STK-Q-07320 | 0 | Flange Lock Nut M10 |
| 1 | 885SP6048G | 0 | 885 SP6048G Inner Panel |
| 8 | STK-Q-07620 | 0 | M10 Plastic Spacer 0.875" |
| 1 | 5500DDS604808FD | 0 | 5500DDS 60" x 48" Cover |
| 1 | 5500DDS604808LD | 0 | 5500DDS 60" x 48" Cover |
| 1 | 5500DDS604808B | 0 | 5500DDS 60" x 48" x 8" Body |
| 2 | 5500DDS604808GP | 0 | 5500DDS Gland Plate |
| 8 | STK-Q-04050-10 | 8 | M6 x 10mm Hexagon Socket Head Machine Screw with Nyseal |
| Qty | Part Number | Rev | Description |
| Parts List | | | |

| | |
|---------------------------------|-------------------------------------------|
| Customer Client | Date |
| Drawn By Dessiné Par | BoxCad: BoxCad Date 08-Sep-14 |
| Material Matière | 12 Ga Cold Rolled A1008 CS Type B (2.5mm) |
| Color Couleur | Asa-61 Grey Finish Fini Smooth |
| Description | Detail Rev. |
| 5500DDS 60" x 48" x 8" Assembly | |
| Part Number Numéro Pièce | Rev. 2 |
| 5500DDS604808 | 0 |

This drawing is confidential and must not be reproduced or used without the consent of EXM

Ce dessin est confidentiel et ne doit pas être reproduit ou utilisé sans le consentement de EXM



TOP

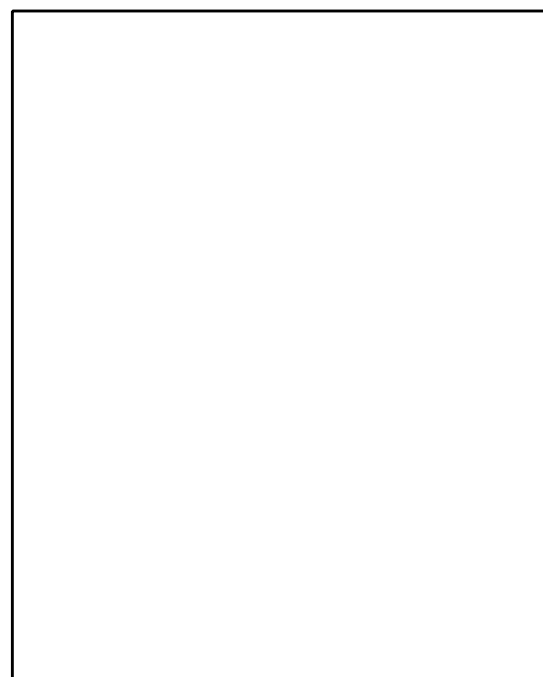

BACK

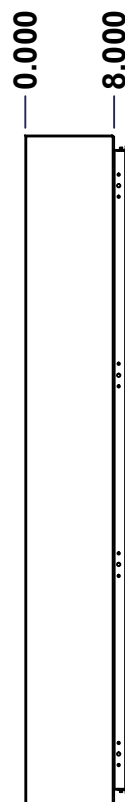

LEFT

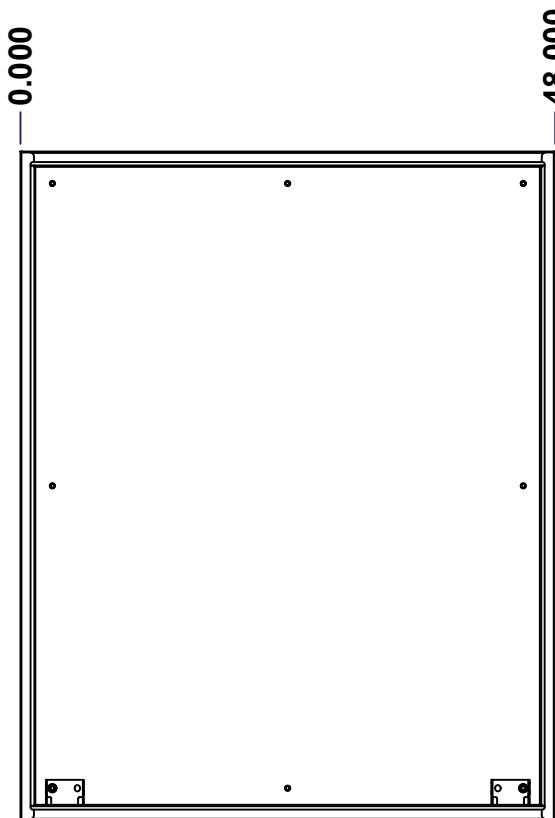

FRONT

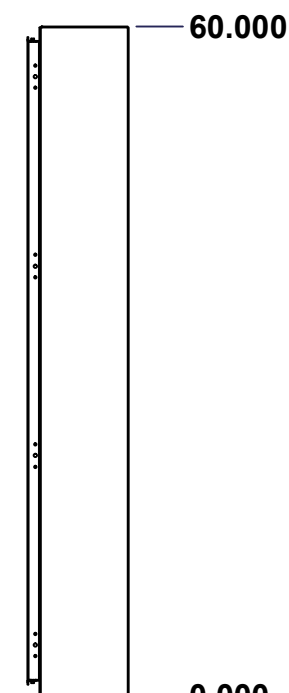

RIGHT

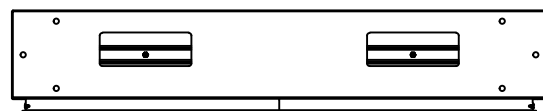

BOTTOM

| No. | Revisions | Date | By/Par |
|-----|-----------|------|--------|
| | | | |
| | | | |
| | | | |
| | | | |

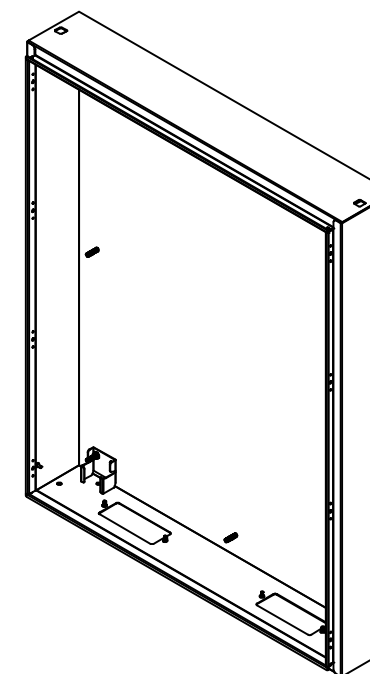

Isometric View



Tél: (450) 979-4373
 Fax: (450) 979-4626
www.exmweb.com

Flatness
Aplatissement
Max 3.0mm
Projection

| | |
|----------------------------------------|----------------|
| Customer Client | Date |
| Drawn By Dessiné Par BoxCad: BoxCad | Date 08-Sep-14 |

Material
Matière 12 Ga Cold Rolled A1008 CS Type B (2.5mm)

Color
Couleur Asa-61 Grey

Finish
Fini Smooth

Description
5500DDS 60" x 48" x 8" Body

Detail Rev.

| | | |
|-----------------------------|----------|----|
| Part Number Numéro Pièce | Rev. | 3 |
| 5500DDS604808B | 0 | 17 |

SEE BILL OF MATERIAL ON LAST PAGE

This drawing is confidential and must not be reproduced or used without the consent of EXM

Ce dessin est confidentiel et ne doit pas être reproduit ou utilisé sans le consentement de EXM

STANDARD FEATURES ARE NOT LISTED IN THIS HOLE TABLE

HOLE TABLE - TOP VIEW (CUSTOM FEATURE ONLY)

| CUT-OUT | XDIM | YDIM | DESCRIPTION |
|---------|--------|-------|-------------------------------|
| 1 | 35.911 | 3.911 | Struts CR400 17.500" (Inside) |
| 2 | 11.911 | 3.911 | Struts CR400 17.500" (Inside) |
| 3 | 35.911 | 3.911 | STUDS M6 x 10mm (Inside) |
| 4 | 30.161 | 3.911 | STUDS M6 x 10mm (Inside) |
| 5 | 41.661 | 3.911 | STUDS M6 x 10mm (Inside) |
| 6 | 11.911 | 3.911 | STUDS M6 x 10mm (Inside) |
| 7 | 6.161 | 3.911 | STUDS M6 x 10mm (Inside) |
| 8 | 17.661 | 3.911 | STUDS M6 x 10mm (Inside) |

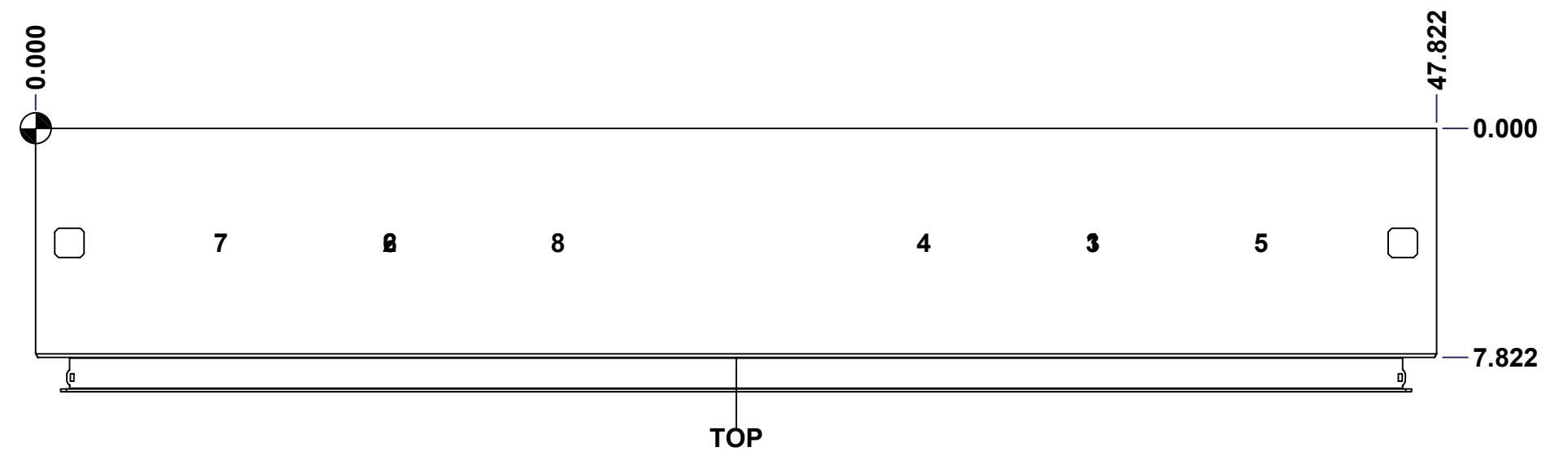

| | | | |
|--|-----------------------------|----------|----|
| | Description | Status | |
| | 5500DDS 60" x 48" x 8" Body | (NULL) | |
| | Part Number Numéro Pièce | Rev. | 4 |
| | 5500DDS604808B | 0 | 17 |

This drawing is confidential and must not be reproduced or used without the consent of EXM

Ce dessin est confidentiel et ne doit pas être reproduit ou utilisé sans le consentement de EXM

| STANDARD FEATURES ARE NOT LISTED IN THIS HOLE TABLE | | | |
|-----------------------------------------------------|-------|-------|-----------------------------|
| HOLE TABLE - RIGHT VIEW (CUSTOM FEATURE ONLY) | | | |
| CUT-OUT | XDIM | YDIM | DESCRIPTION |
| 1 | 6.411 | 3.286 | GND STUD M6 x 16mm (Inside) |

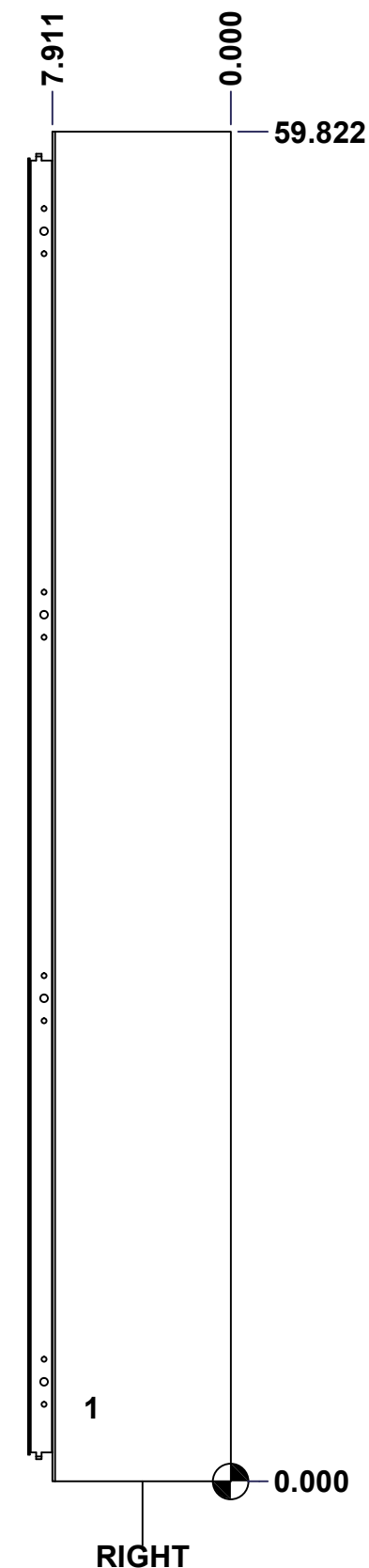

| | | | |
|--|-----------------------------|----------|----|
| | Description | Status | |
| | 5500DDS 60" x 48" x 8" Body | (NULL) | |
| | Part Number Numéro Pièce | Rev. | 5 |
| | 5500DDS604808B | 0 | 17 |

This drawing is confidential and must not be reproduced or used without the consent of EXM

Ce dessin est confidentiel et ne doit pas être reproduit ou utilisé sans le consentement de EXM

STANDARD FEATURES ARE NOT LISTED IN THIS HOLE TABLE

HOLE TABLE - BOTTOM VIEW (CUSTOM FEATURE ONLY)

| CUT-OUT | XDIM | YDIM | DESCRIPTION |
|---------|--------|-------|----------------------------|
| 1 | 7.286 | 3.411 | GP STUD M6 x 16mm (Inside) |
| 2 | 16.536 | 3.411 | GP STUD M6 x 16mm (Inside) |
| 3 | 31.286 | 3.411 | GP STUD M6 x 16mm (Inside) |
| 4 | 40.536 | 3.411 | GP STUD M6 x 16mm (Inside) |
| ----- | | | |
| 5 | 3.911 | 0.911 | RND Ø0.500 |
| 6 | 0.911 | 3.911 | RND Ø0.500 |
| 7 | 3.911 | 6.911 | RND Ø0.500 |
| 8 | 43.911 | 0.911 | RND Ø0.500 |
| 9 | 46.911 | 3.911 | RND Ø0.500 |
| 10 | 43.911 | 6.911 | RND Ø0.500 |

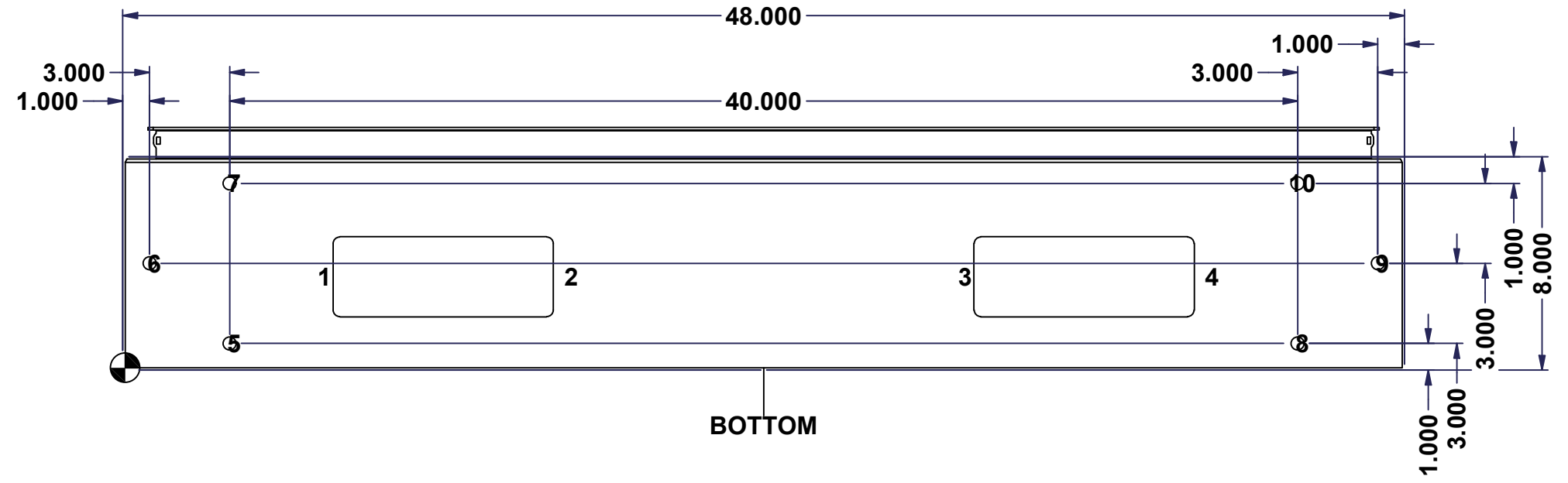

| | | |
|--|-----------------------------|--------------|
| | Description | Status |
| | 5500DDS 60" x 48" x 8" Body | (NULL) |
| | Part Number Numéro Pièce | Rev. |
| | 5500DDS604808B | 0 / 6 |
| | | 17 |

This drawing is confidential and must not be reproduced or used without the consent of EXM

Ce dessin est confidentiel et ne doit pas être reproduit ou utilisé sans le consentement de EXM

| STANDARD FEATURES ARE NOT LISTED IN THIS HOLE TABLE | | | |
|------------------------------------------------------------|-------|-------|-----------------------------|
| HOLE TABLE - LEFT VIEW (CUSTOM FEATURE ONLY) | | | |
| CUT-OUT | XDIM | YDIM | DESCRIPTION |
| 1 | 6.411 | 3.286 | GND STUD M6 x 16mm (Inside) |

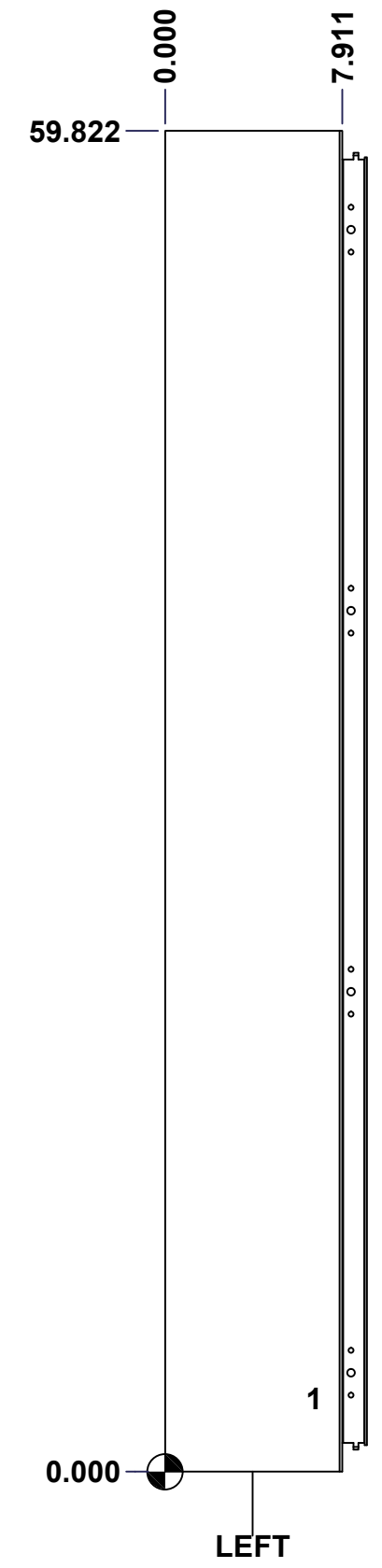

| | | | |
|--|-----------------------------|----------|----|
| | Description | Status | |
| | 5500DDS 60" x 48" x 8" Body | (NULL) | |
| | Part Number Numéro Pièce | Rev. | 7 |
| | 5500DDS604808B | 0 | 17 |

This drawing is confidential and must not be reproduced or used without the consent of EXM

Ce dessin est confidentiel et ne doit pas être reproduit ou utilisé sans le consentement de EXM

STANDARD FEATURES ARE NOT LISTED IN THIS HOLE TABLE

HOLE TABLE - BACK VIEW (CUSTOM FEATURE ONLY)

| CUT-OUT | XDIM | YDIM | DESCRIPTION |
|---------|--------|--------|-----------------------------|
| 1 | 2.786 | 2.786 | IP STUD M10 x 40mm (Inside) |
| 2 | 45.036 | 2.786 | IP STUD M10 x 40mm (Inside) |
| 3 | 2.786 | 29.911 | IP STUD M10 x 40mm (Inside) |
| 4 | 45.036 | 29.911 | IP STUD M10 x 40mm (Inside) |
| 5 | 2.786 | 57.036 | IP STUD M10 x 40mm (Inside) |
| 6 | 45.036 | 57.036 | IP STUD M10 x 40mm (Inside) |
| 7 | 23.911 | 2.786 | IP STUD M10 x 40mm (Inside) |
| 8 | 23.911 | 57.036 | IP STUD M10 x 40mm (Inside) |

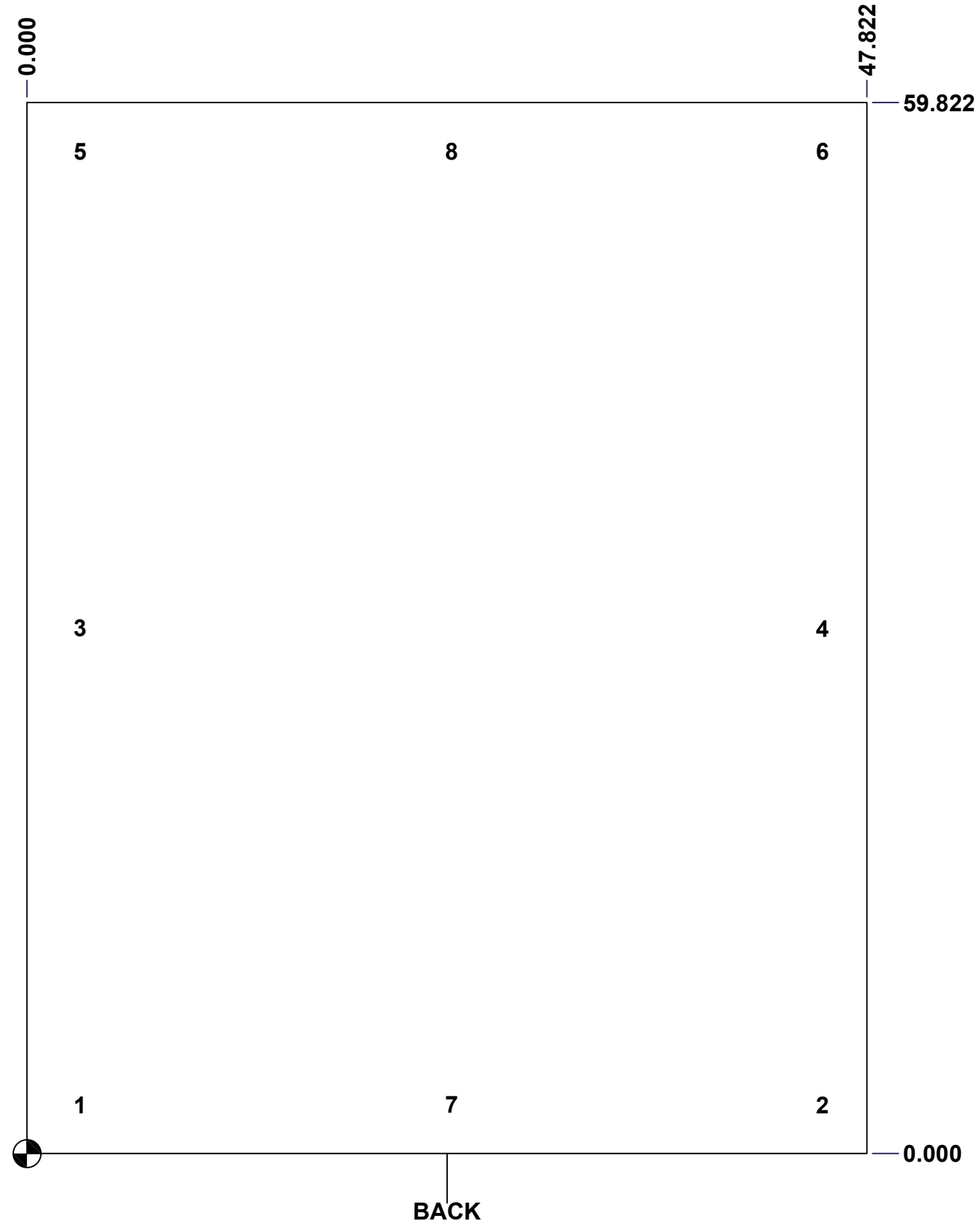

| | | |
|--|-----------------------------|--------------|
| | Description | Status |
| | 5500DDS 60" x 48" x 8" Body | (NULL) |
| | Part Number Numéro Pièce | Rev. |
| | 5500DDS604808B | 0 / 8 |
| | | 17 |

This drawing is confidential and must not be reproduced or used without the consent of EXM

Ce dessin est confidentiel et ne doit pas être reproduit ou utilisé sans le consentement de EXM

| No. | Revisions | Date | By/Par |
|-----|-----------|------|--------|
| | | | |
| | | | |
| | | | |
| | | | |
| | | | |

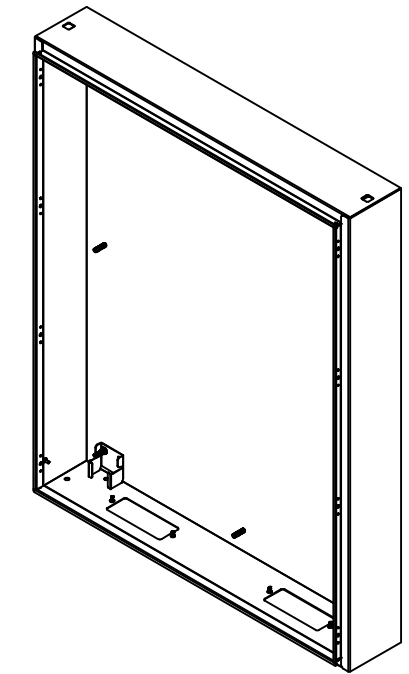

Isometric View

| | | | |
|---|-------------------|---|------------------------------------------|
| 6 | STK-Q-16030 | 0 | Stud M6 x 10mm Steel |
| 6 | STK-Q-07220 | 1 | M6 Nylon Insert Lock Nut |
| 2 | STK-Q-74930 | 0 | Eyebolt Lifting Angle (6.750") |
| 1 | STK-P-02400S | 0 | Powder Paint (Asa-61 Grey / Smooth) |
| 2 | STK-Q-07320 | 0 | Flange Lock Nut M10 |
| 2 | STK-Q-07618 | 1 | 5500 Series Inner Panel Support Bracket |
| 8 | STK-Q-16100 | 0 | Stud M10 x 40mm Steel |
| 1 | 5500DDS604808BT-P | 0 | 5500DDS 48" x 8" Bottom Part |
| 1 | 5500DDS604808T-P | 0 | 5500DDS 48" x 8" Top Part |
| 1 | 5500DDS604808RS-P | 0 | 5500DDS 60" x 48" Right Part |
| 1 | 5500DDS604808LS-P | 0 | 5500DDS 60" x 48" Left Part |
| 1 | 5500DDS604808B-P | 0 | 5500DDS 60" x 48" Back Part |
| 2 | CR400MS_17.5 | 0 | Commercial Roll Mild Steel (17.5in long) |
| 6 | STK-Q-16080 | 0 | Ground Stud M6 x 16mm Steel |

| Qty | Part Number | Rev | Description |
|------------|-------------|-----|-------------|
| Parts List | | | |

| | | |
|------------------------------------------------------|--------------------------------------------------------------------------------------------------|------------------------------------------------------------------|
| | Tél: (450) 979-4373 Fax: (450) 979-4626 www.exmweb.com | Flatness Aplatissement Max 3.0mm |
| | Projection | Customer Client |
| Drawn By Dessiné Par BoxCad: BoxCad | Date 08-Sep-14 | Material Matière 12 Ga Cold Rolled A1008 CS Type B (2.5mm) |
| Color Couleur Asa-61 Grey | Finish Fini Smooth | Description 5500DDS 60" x 48" x 8" Body |
| Part Number Numéro Pièce 5500DDS604808B | Detail Rev. Rev. 0 | 9 17 |

This drawing is confidential and must not be reproduced or used without the consent of EXM

Ce dessin est confidentiel et ne doit pas être reproduit ou utilisé sans le consentement de EXM

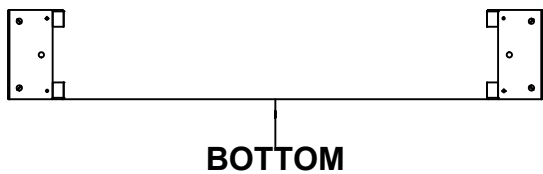
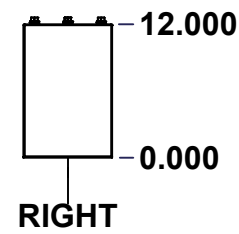
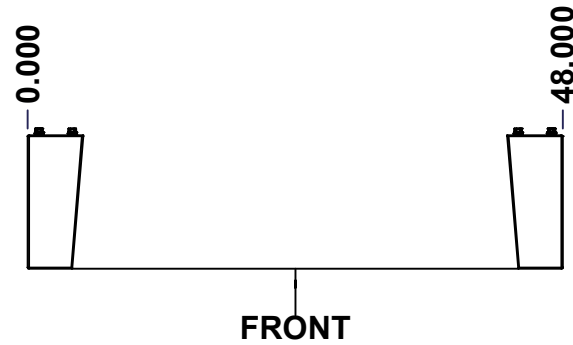
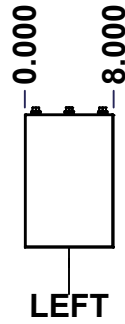
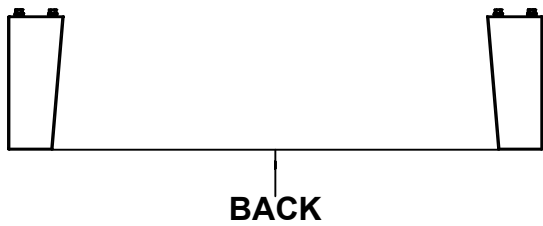
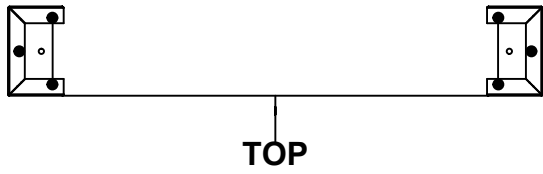

| No. | Revisions | Date | By/Par |
|-----|-----------|------|--------|
| | | | |
| | | | |
| | | | |
| | | | |
| | | | |

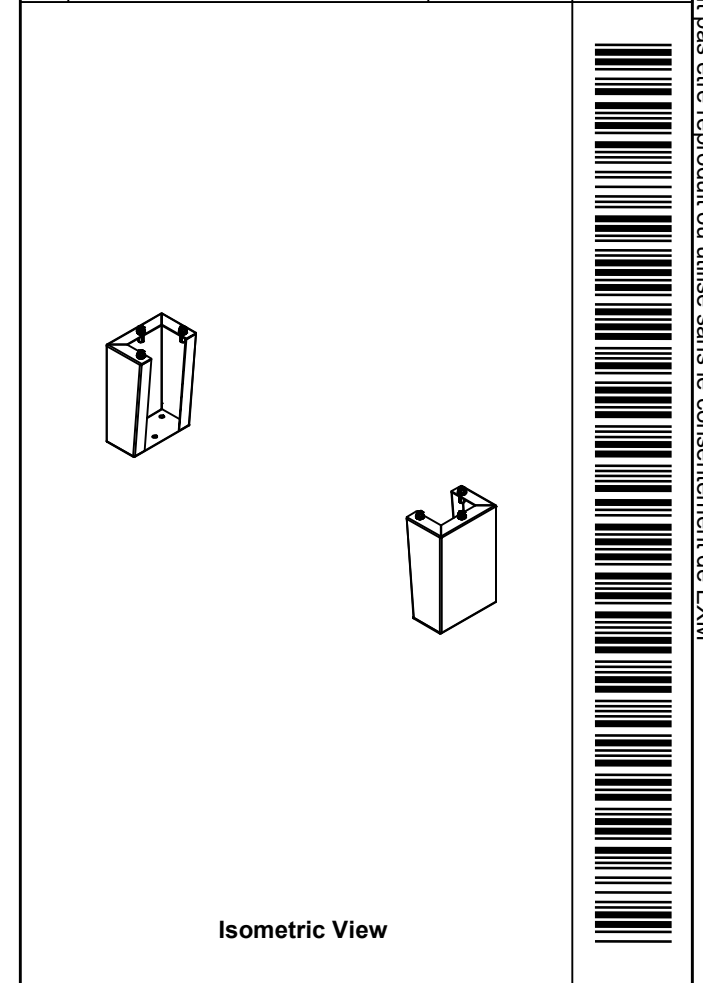

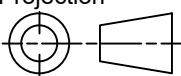
| | | |
|----------------------------------------------------------------------------------------------------------------------------------------------------------------------------------------|-------------------------------------------|-----------------------------------------------------------------------------------------------------------------------------------------------|
|  Tél: (450) 979-4373 Fax: (450) 979-4626 www.exmweb.com | | Flatness Aplatissement Max 3.0mm Projection  |
| Customer Client | Date | |
| Drawn By Dessiné Par | BoxCad: BoxCad | Date 08-Sep-14 |
| Material Matière | 12 Ga Cold Rolled A1008 CS Type B (2.5mm) | |
| Color Couleur | Asa-61 Grey | Finish Fini Smooth |
| Description 885 MFHD 12" x 8" Mounting Feet | | Detail Rev. |
| Part Number Numéro Pièce | Rev. 0 | 10 17 |

SEE BILL OF MATERIAL ON LAST PAGE

5500DDS604808MF

This drawing is confidential and must not be reproduced or used without the consent of EXM

Ce dessin est confidentiel et ne doit pas être reproduit ou utilisé sans le consentement de EXM

| No. | Revisions | Date | By/Par |
|-----|-----------|------|--------|
| | | | |
| | | | |
| | | | |
| | | | |
| | | | |

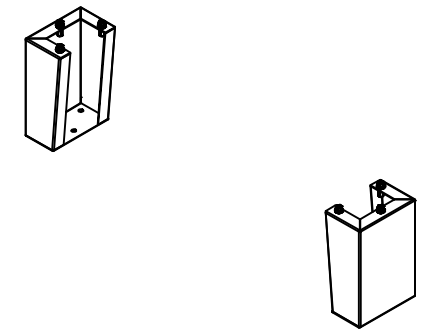

Isometric View

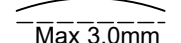
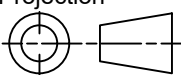

| | | |
|----------------------------------------------------------------------------------------------------------------------------------------------------------------------------------------|-------------------------------------------|-------------------------------------------------------------------------------------------------------------------------------------------------------------------------------------------------------------------------------------|
|  Tél: (450) 979-4373 Fax: (450) 979-4626 www.exmweb.com | | Flatness Aplatissement  Max 3.0mm Projection  |
| Customer Client | Date | |
| Drawn By Dessiné Par | BoxCad: BoxCad | Date 08-Sep-14 |
| Material Matière | 12 Ga Cold Rolled A1008 CS Type B (2.5mm) | |
| Color Couleur | Asa-61 Grey | Finish Fini Smooth |
| Description | | Detail Rev. |
| 885 MFHD 12" x 8" Mounting Feet | | |
| Part Number Numéro Pièce | Rev. | 11 |
| 5500DDS604808MF | 0 | 17 |

| Qty | Part Name | Rev | Description |
|------------|---------------------|-----|--------------------------------------------|
| 1 | STK-P-02400S | 0 | Powder Paint (Asa-61 Grey / Smooth) |
| 6 | RIVET_NUT_M10_FH_CE | 0 | Rivet Nut M10 (Low Profile Close End) |
| 1 | 5500DDS604808MFR-P | 0 | 885 MFHD 12" x 8" Right Mounting Feet Part |
| 1 | 5500DDS604808MFL-P | 0 | 885 MFHD 12" x 8" Left Mounting Feet Part |
| 1 | STK-K-11600 | 2 | 885 MF Accessory Kit |
| Parts List | | | |

This drawing is confidential and must not be reproduced or used without the consent of EXM

Ce dessin est confidentiel et ne doit pas être reproduit ou utilisé sans le consentement de EXM

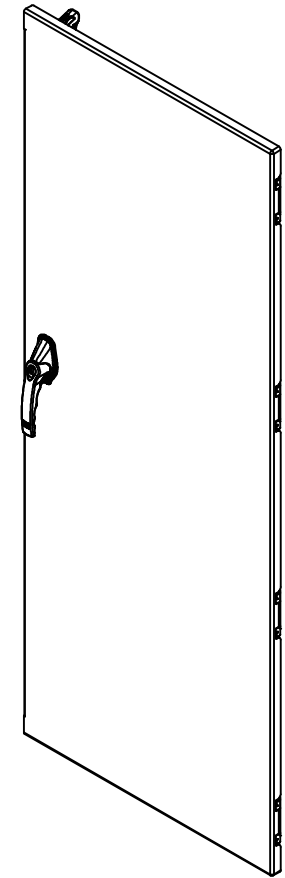
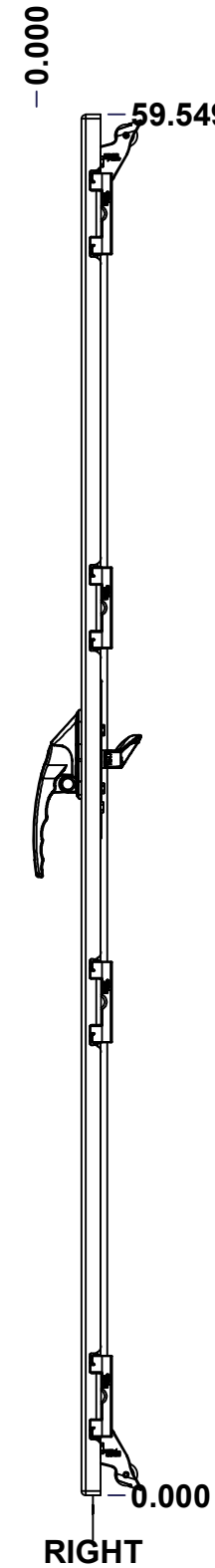
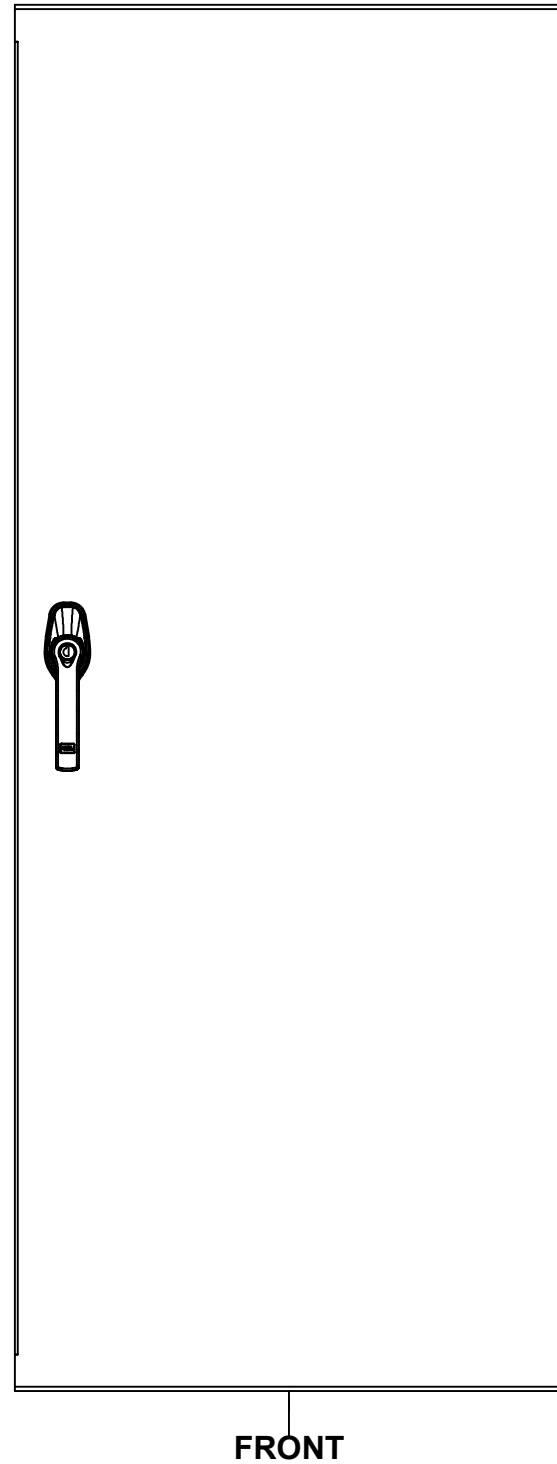
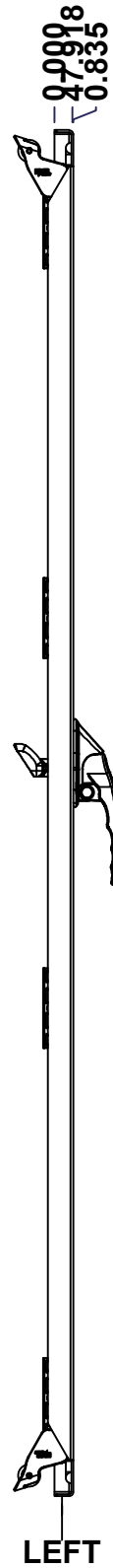
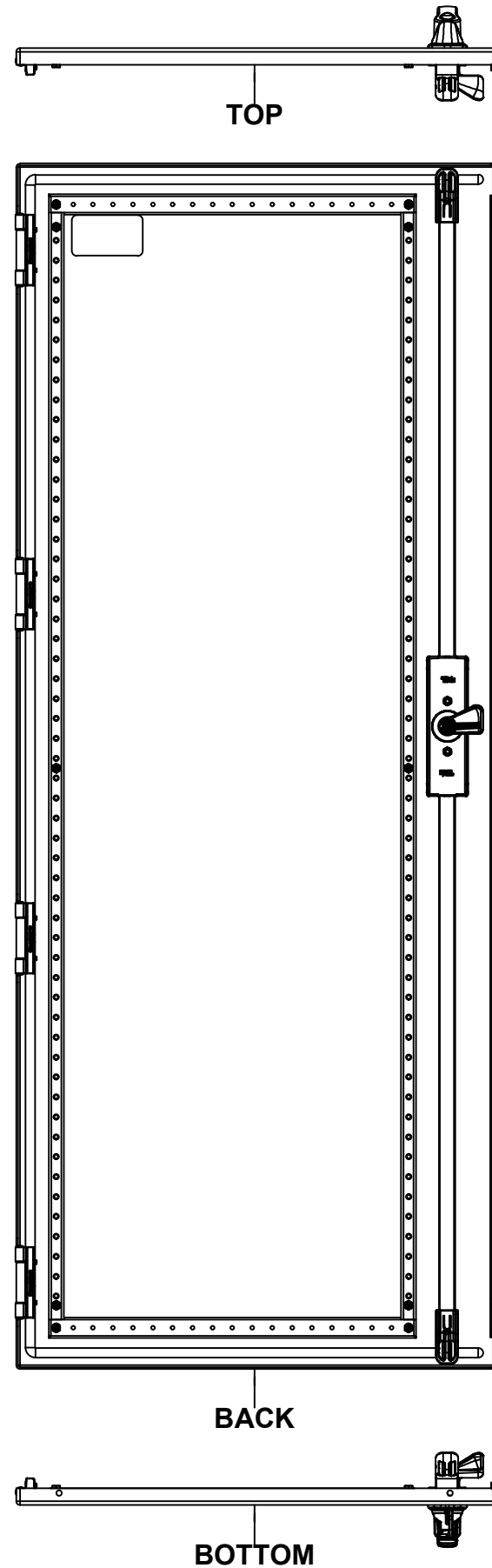

Isometric View

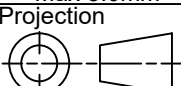

| No. | Revisions | Date | By/Par |
|-----|-----------|------|--------|
| | | | |
| | | | |
| | | | |
| | | | |

| | | |
|----------------------------------------------------------------------------------------------------------------------------------------------------------------------------------------|-------------------------------------------|-----------------------------------------------------------------------------------------------------------------------------------------------|
|  Tél: (450) 979-4373 Fax: (450) 979-4626 www.exmweb.com | | Flatness Aplatissement Max 3.0mm Projection  |
| Customer Client | Date | |
| Drawn By Dessiné Par | BoxCad: BoxCad | Date 08-Sep-14 |
| Material Matière | 12 Ga Cold Rolled A1008 CS Type B (2.5mm) | |
| Color Couleur | Asa-61 Grey | Finish Fini Smooth |
| Description 5500DDS 60" x 48" Cover | | Detail Rev. |
| Part Number Numéro Pièce | Rev. 0 | 12 / 17 |

SEE BILL OF MATERIAL ON LAST PAGE

5500DDS604808LD

This drawing is confidential and must not be reproduced or used without the consent of EXM

Ce dessin est confidentiel et ne doit pas être reproduit ou utilisé sans le consentement de EXM

| STANDARD FEATURES ARE NOT LISTED IN THIS HOLE TABLE | | | |
|-----------------------------------------------------|--------|--------|------------------------------|
| HOLE TABLE - FRONT VIEW (CUSTOM FEATURE ONLY) | | | |
| CUT-OUT | XDIM | YDIM | DESCRIPTION |
| 1 | 1.983 | 2.028 | STUD M6 x 18mm (Inside) |
| 2 | 1.983 | 29.675 | STUD M6 x 18mm (Inside) |
| 3 | 1.983 | 57.521 | STUD M6 x 18mm (Inside) |
| 4 | 1.983 | 3.139 | STUD M6 x 18mm (Inside) |
| 5 | 1.983 | 56.409 | STUD M6 x 18mm (Inside) |
| 6 | 19.390 | 2.028 | STUD M6 x 18mm (Inside) |
| 7 | 19.390 | 29.675 | STUD M6 x 18mm (Inside) |
| 8 | 19.390 | 57.521 | STUD M6 x 18mm (Inside) |
| 9 | 19.390 | 3.139 | STUD M6 x 18mm (Inside) |
| 10 | 19.390 | 56.409 | STUD M6 x 18mm (Inside) |
| 11 | 21.311 | 6.118 | LARGE CBAR GUIDE (Inside) |
| 12 | 21.311 | 53.430 | LARGE CBAR GUIDE (Inside) |
| ----- | ----- | ----- | ----- |
| 13 | 21.311 | 31.743 | HANDLE 885 ESL2A-APHK @ 0.0° |

—47.918

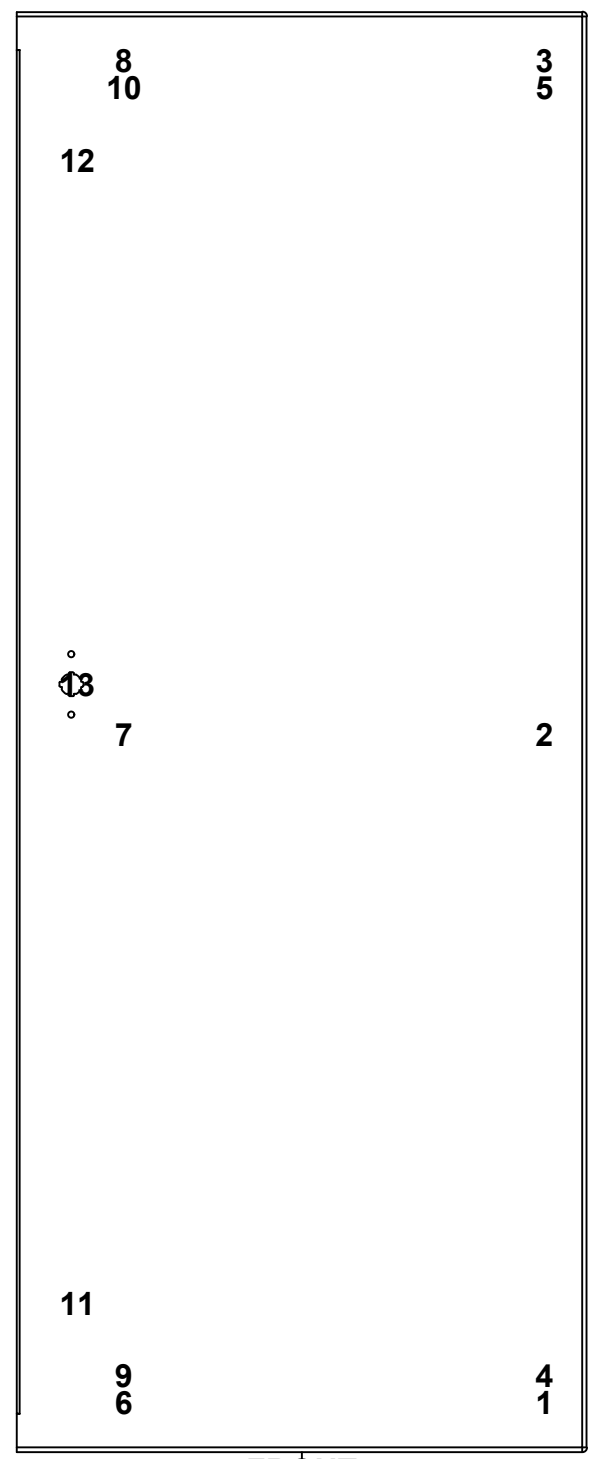

0.000
—59.549

FRONT

0.000

| | | | |
|--|-----------------------------|----------|----|
| | Description | Status | |
| | 5500DDS 60" x 48" Cover | (NULL) | |
| | Part Number Numéro Pièce | Rev. | 13 |
| | 5500DDS604808LD | 0 | 17 |

This drawing is confidential and must not be reproduced or used without the consent of EXM

Ce dessin est confidentiel et ne doit pas être reproduit ou utilisé sans le consentement de EXM

| No. | Revisions | Date | By/Par |
|-----|-----------|------|--------|
| | | | |
| | | | |
| | | | |
| | | | |
| | | | |

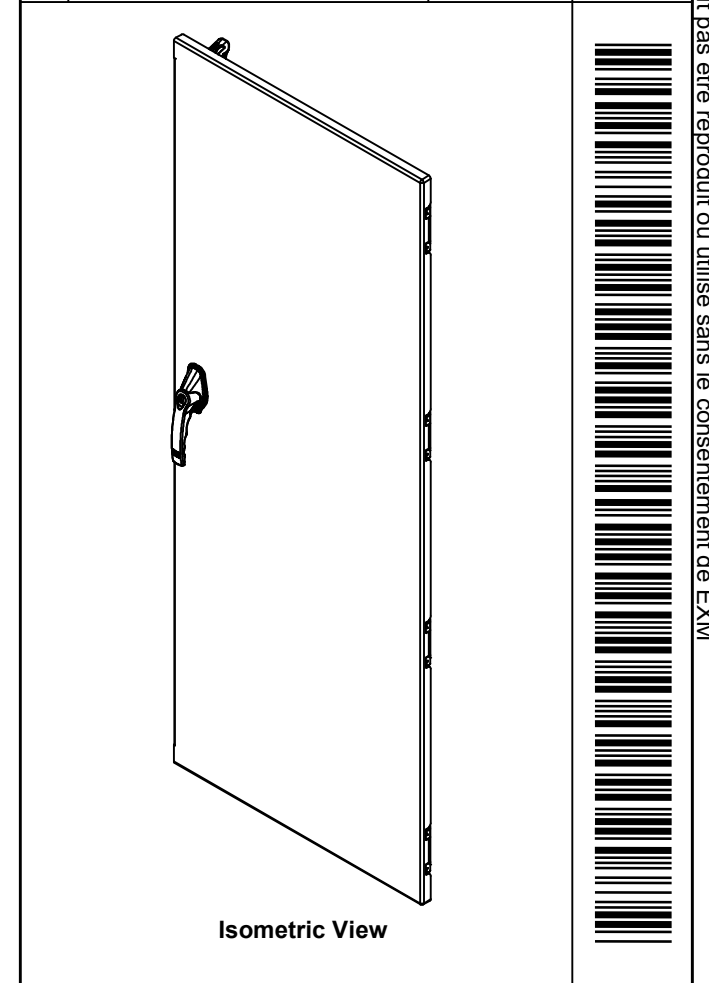

| 1 | STK-Q-47521 | 2 | 5500 DDS Lower Closing Bar 60" |
|------------|-------------------|-----|----------------------------------------------------------|
| 1 | STK-Q-47511 | 2 | 5500 DDS Upper Closing Bar 60" |
| 1 | STK-A-03986-36 | 2 | Gearbox Counterclockwise Assembly (36.0mm) |
| 1 | 885ESL2A-APHK | 6 | 885 ESL2A-APHK - Zinc Die Cast L-Handle Padlockable Assy |
| 1 | STK-P-02400S | 0 | Powder Paint (Asa-61 Grey / Smooth) |
| 1 | STK-S-00100 | 0 | 3.5" x 2" Silver Milar Flexcon Sticker |
| 1 | STK-K-10700 | 3 | 5500 DDS - Door Stiffener Assembly |
| 2 | STK-Q-16410 | 0 | Guide Stud - Largel (No Paint Cap Required) |
| 10 | STK-Q-16055 | 1 | M6 x 18mm Stud (No Paint Cap Required) |
| 1 | 5500DDS604808LDG | 0 | 5500DDS 60" x 48" Lock Door Gasket |
| 1 | 5500DDS604808LD-P | 0 | 5500DDS 60" x 48" Lock Door Part |
| 2 | STK-A-90025 | 0 | 9500 - Cabinet Closing Bar End (Large) |
| 4 | STK-K-09860 | 7 | Cabinet Hinge with Captive Pins |
| QTY | Part Number | Rev | Description |
| Parts List | | | |

| | | |
|--------------------------|--------------------------------------------------------------------------------------------------|----------------------------------------|
| | Tél: (450) 979-4373 Fax: (450) 979-4626 www.exmweb.com | Flatness Aplatissement Max 3.0mm |
| | Projection | Date |
| Customer Client | Date | Date 08-Sep-14 |
| Drawn By Dessiné Par | BoxCad: BoxCad | |
| Material Matière | 12 Ga Cold Rolled A1008 CS Type B (2.5mm) | |
| Color Couleur | Asa-61 Grey | Finish Fini Smooth |
| Description | 5500DDS 60" x 48" Cover | |
| Part Number Numéro Pièce | 5500DDS604808LD | Detail Rev. Rev. 14 0 17 |

This drawing is confidential and must not be reproduced or used without the consent of EXM

Ce dessin est confidentiel et ne doit pas être reproduit ou utilisé sans le consentement de EXM

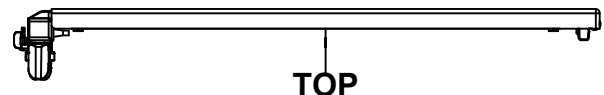

TOP

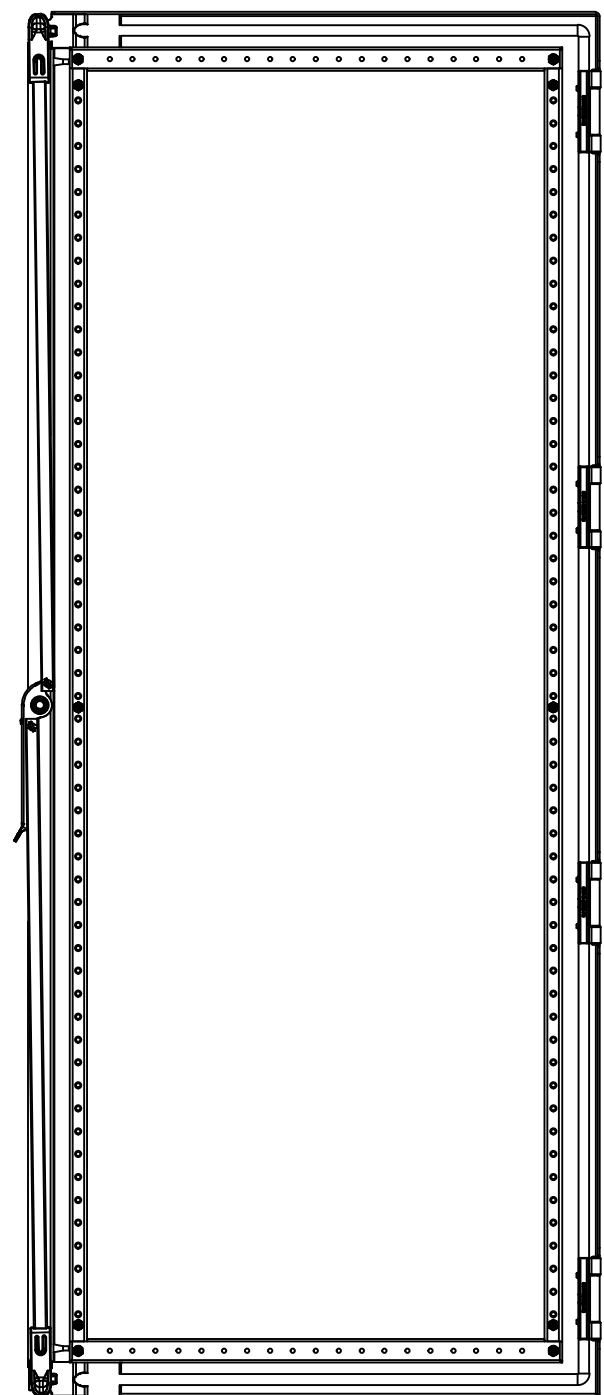

BACK

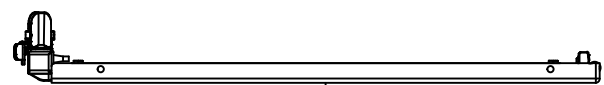

BOTTOM

0.000
0.000
0.835

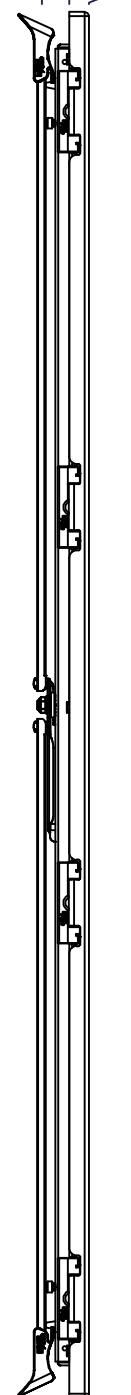

LEFT

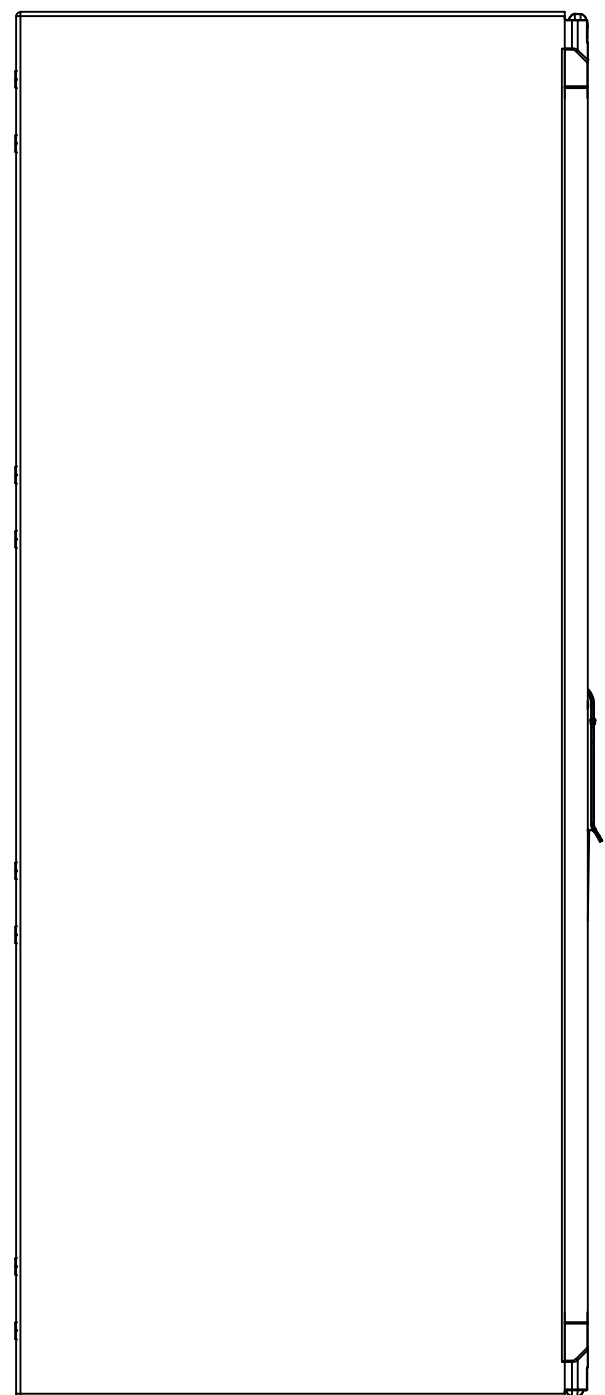

FRONT

-47.918
59.549

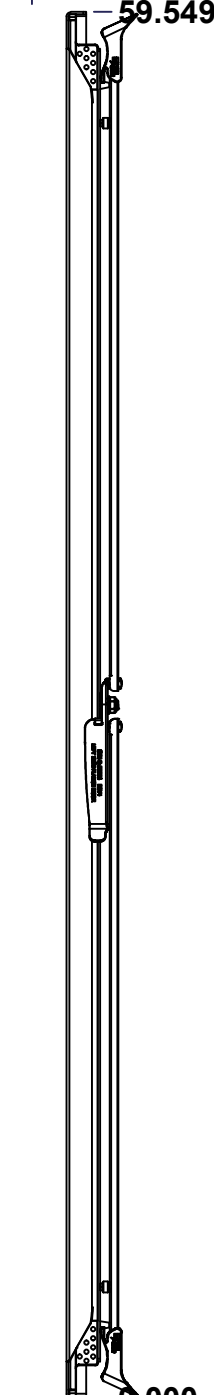

RIGHT

0.000

| No. | Revisions | Date | By/Par |
|-----|-----------|------|--------|
| | | | |
| | | | |
| | | | |
| | | | |
| | | | |

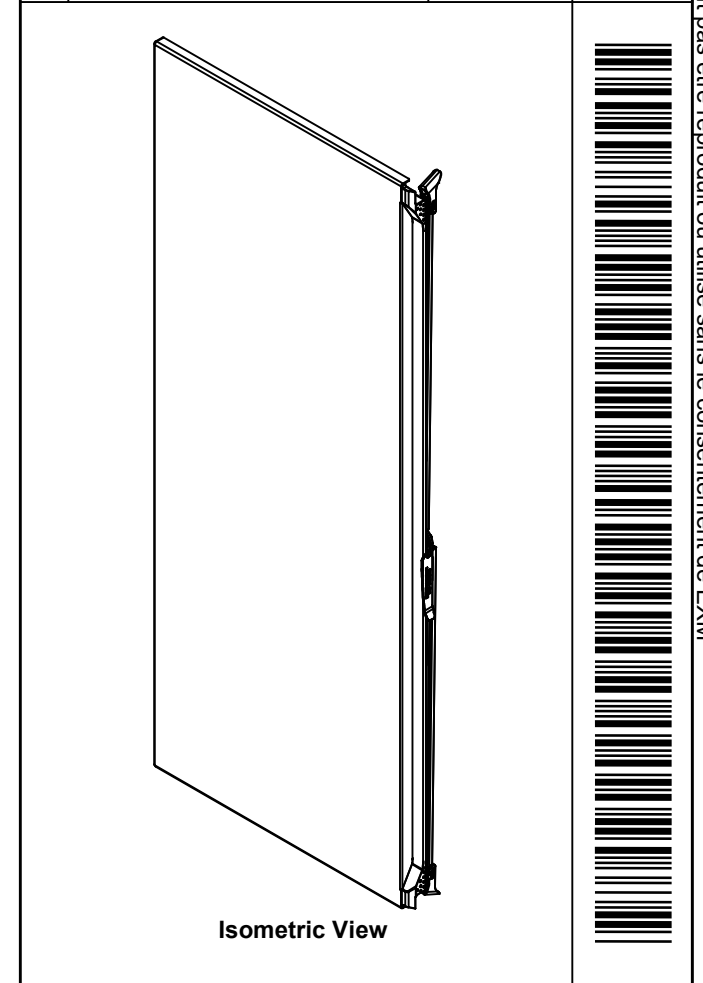

Isometric View



Tél: (450) 979-4373
Fax: (450) 979-4626
www.exmweb.com

Flatness
Aplatissement

Max 3.0mm

Projection

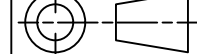

| | |
|---------------------------------------------------------------|-----------------------|
| Customer Client | Date |
| Drawn By Dessiné Par BoxCad: BoxCad | Date 08-Sep-14 |
| Material Matière 12 Ga Cold Rolled A1008 CS Type B (2.5mm) | |
| Color Couleur Asa-61 Grey | Finish Fini Smooth |

| | |
|----------------------------------------------------|---------------------|
| Description 5500DDS 60" x 48" Cover | Detail Rev. |
| Part Number Numéro Pièce 5500DDS604808FD | Rev. 15 0 |

SEE BILL OF MATERIAL ON LAST PAGE

This drawing is confidential and must not be reproduced or used without the consent of EXM

Ce dessin est confidentiel et ne doit pas être reproduit ou utilisé sans le consentement de EXM

STANDARD FEATURES ARE NOT LISTED IN THIS HOLE TABLE

HOLE TABLE - FRONT VIEW (CUSTOM FEATURE ONLY)

| CUT-OUT | XDIM | YDIM | DESCRIPTION |
|---------|--------|--------|---------------------------|
| 1 | 2.000 | 2.028 | STUD M6 x 18mm (Inside) |
| 2 | 2.000 | 29.675 | STUD M6 x 18mm (Inside) |
| 3 | 2.000 | 57.521 | STUD M6 x 18mm (Inside) |
| 4 | 2.000 | 3.139 | STUD M6 x 18mm (Inside) |
| 5 | 2.000 | 56.409 | STUD M6 x 18mm (Inside) |
| 6 | 22.407 | 2.028 | STUD M6 x 18mm (Inside) |
| 7 | 22.407 | 29.675 | STUD M6 x 18mm (Inside) |
| 8 | 22.407 | 57.521 | STUD M6 x 18mm (Inside) |
| 9 | 22.407 | 3.139 | STUD M6 x 18mm (Inside) |
| 10 | 22.407 | 56.409 | STUD M6 x 18mm (Inside) |
| 11 | 24.061 | 4.774 | SMALL CBAR GUIDE (Inside) |
| 12 | 24.061 | 54.774 | SMALL CBAR GUIDE (Inside) |
| 13 | 24.061 | 29.774 | STUD M10 x 20mm (Inside) |

- 0.000

- 47.918
- 59.549

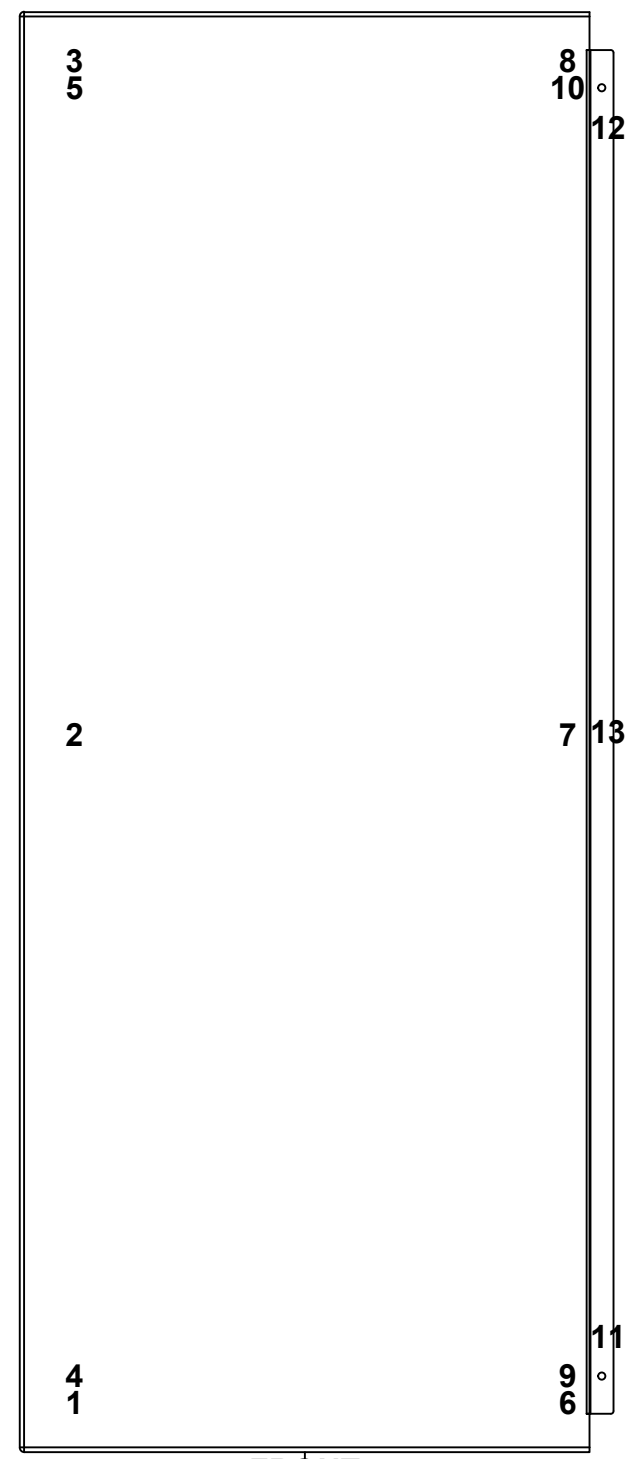

FRONT

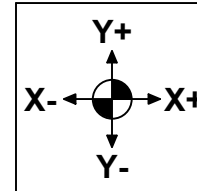

| | | | |
|-----------------------------|--|--------|----|
| Description | | Status | |
| 5500DDS 60" x 48" Cover | | (NULL) | |
| Part Number Numéro Pièce | | Rev. | 16 |
| 5500DDS604808FD | | 0 | 17 |

This drawing is confidential and must not be reproduced or used without the consent of EXM

Ce dessin est confidentiel et ne doit pas être reproduit ou utilisé sans le consentement de EXM

| No. | Revisions | Date | By/Par |
|-----|-----------|------|--------|
| | | | |
| | | | |
| | | | |
| | | | |
| | | | |

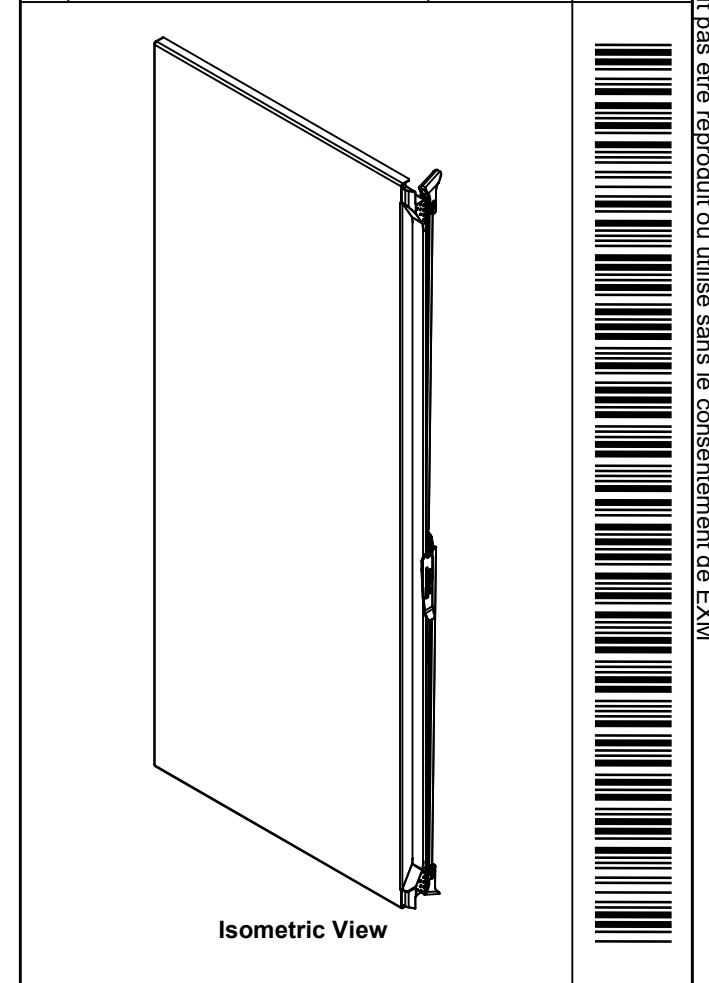

| | | | |
|----|-------------------|---|--------------------------------------------|
| 1 | STK-P-02400S | 0 | Powder Paint (Asa-61 Grey / Smooth) |
| 1 | STK-G-03400 | 1 | 5500 DD Lower Flange Door Gasket |
| 1 | STK-G-03300 | 1 | 5500 DD Upper Flange Door Gasket |
| 2 | STK-Q-90045 | 0 | Cabinet - Closing Bar End |
| 2 | STK-Q-45670-60 | 2 | 5500 DDS - Flange Door Closing Bar |
| 1 | STK-K-50556 | 4 | 9500 DD - Flange Door Handle Assy |
| 1 | STK-K-20700 | 3 | 5500 DDS - Flange Door Stiffener Assembly |
| 1 | STK-Q-16122 | 1 | Stud M10 x 20mm |
| 2 | STK-Q-16405 | 6 | Guide Stud - Small (No Paint Cap Required) |
| 10 | STK-Q-16055 | 1 | M6 x 18mm Stud (No Paint Cap Required) |
| 1 | STK-G-00701 | 0 | 1" x 1/4" Self-Adhesive Neoprene Gasket |
| 1 | 5500DDS604808FDG | 0 | 5500DDS 60" x 48" Flange Door Gasket |
| 1 | 5500DDS604808FD-P | 0 | 5500DDS 60" x 48" Flange Door Part |
| 4 | STK-K-09860 | 7 | Cabinet Hinge with Captive Pins |

| QTY | Part Number | Rev | Description |
|------------|-------------|-----|-------------|
| Parts List | | | |

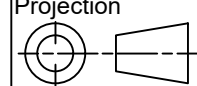
| | | |
|----------------------------------------------------------------------------------------------------------------------------------------------------------------------------------------|-------------------------------------------|---------------------------------------------------------------------------------------|
|  Tél: (450) 979-4373 Fax: (450) 979-4626 www.exmweb.com | Flatness Aplatissement | Max 3.0mm |
| | Projection |  |
| Customer Client | Date | |
| Drawn By Dessiné Par | BoxCad: BoxCad | Date 08-Sep-14 |
| Material Matière | 12 Ga Cold Rolled A1008 CS Type B (2.5mm) | |
| Color Couleur | Asa-61 Grey | Finish Fini Smooth |
| Description | Detail Rev. | |
| 5500DDS 60" x 48" Cover | | |
| Part Number Numéro Pièce | Rev. | 17 |
| 5500DDS604808FD | 0 | 17 |

This drawing is confidential and must not be reproduced or used without the consent of EXM

Ce dessin est confidentiel et ne doit pas être reproduit ou utilisé sans le consentement de EXM



TOP

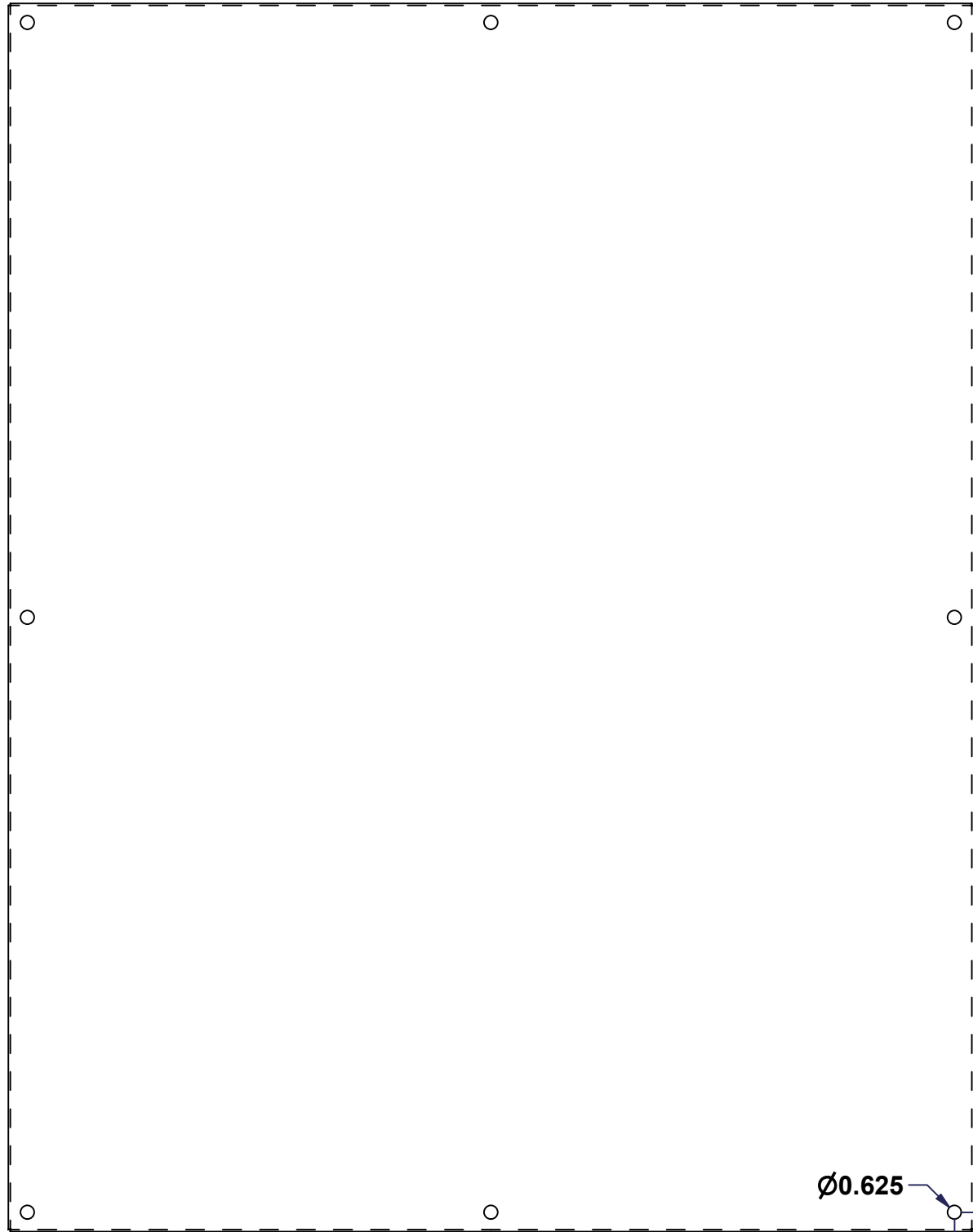

FRONT

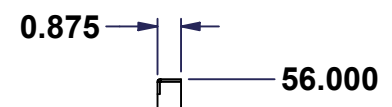

RIGHT

SEE BILL OF MATERIAL ON LAST PAGE

| No. | Revisions | Date | By/Par |
|-----|-----------|------|--------|
| | | | |
| | | | |
| | | | |
| | | | |
| | | | |

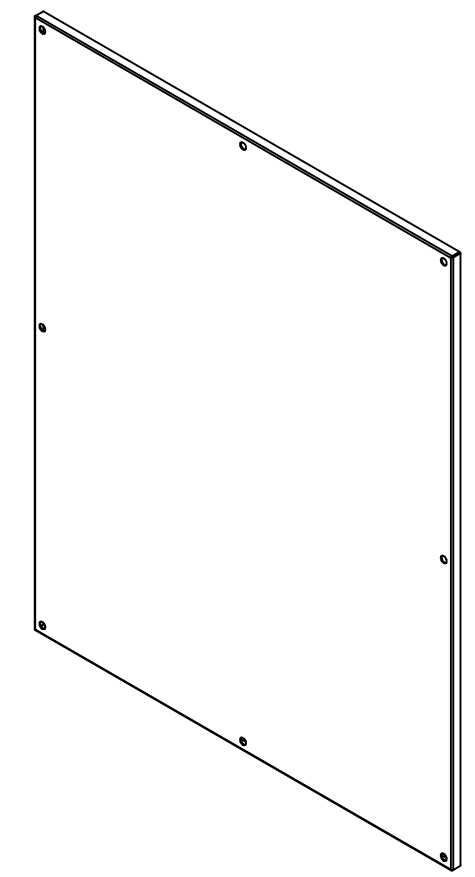

Isometric View



Tél: (450) 979-4373
 Fax: (450) 979-4626
 www.exmweb.com

Flatness
 Aplatissement
 Max 3.0mm
 Projection

| | |
|----------------------------------------------|------------------|
| Customer Client | Date |
| Drawn By / Dessiné Par: BoxCad | Date: 04/11/2009 |
| Material / Matière: 12 Ga Galvanized (2.5mm) | |

| | |
|----------------------------|--------------------------|
| Color / Couleur: Unpainted | Finish / Fini: Unpainted |
|----------------------------|--------------------------|

| | |
|--------------------------------------|-------------|
| Description: 885 SP6048G Inner Panel | Detail Rev. |
|--------------------------------------|-------------|

| | | |
|----------------------------------------|--------|-------|
| Part Number / Numéro Pièce: 885SP6048G | Rev. 0 | 1 / 2 |
|----------------------------------------|--------|-------|

This drawing is confidential and must not be reproduced or used without the consent of EXM

Ce dessin est confidentiel et ne doit pas être reproduit ou utilisé sans le consentement de EXM

| No. | Revisions | Date | By/Par |
|-----|-----------|------|--------|
| | | | |
| | | | |
| | | | |
| | | | |
| | | | |

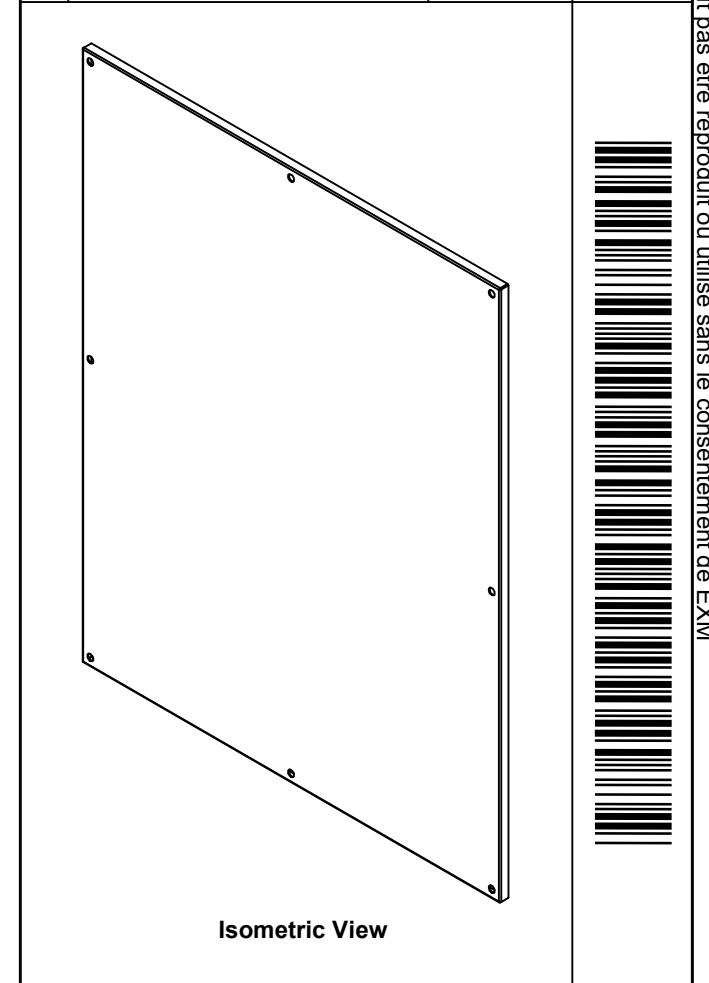

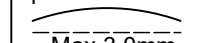
| | | |
|----------------------------------------------------------------------------------------------------------------------------------------------------|--------------------------|---------------------------------------------------------------------------------------------------------------------------------|
|  Tél: (450) 979-4373 Fax: (450) 979-4626 www.exmweb.com | | Flatness Aplatissement  Max 3.0mm |
| Customer Client | | Date |
| Drawn By Dessiné Par BoxCad | | Date 04/11/2009 |
| Material Matière 12 Ga Galvanized (2.5mm) | | |
| Color Couleur Unpainted | Finish Fini Unpainted | |
| Description 885 SP6048G Inner Panel | | Detail Rev. |
| Part Number Numéro Pièce 885SP6048G | | Rev. 0 |

| Qty | Part Number | Rev | Description |
|------------|--------------|-----|------------------------------|
| 1 | 885SP6048G-P | 0 | 885 SP6048G Inner Panel Part |
| Parts List | | | |

2
2