

This drawing is confidential and must not be reproduced or used without the consent of EXM

Ce dessin est confidentiel et ne doit pas être reproduit ou utilisé sans le consentement de EXM

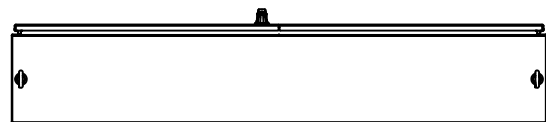

TOP

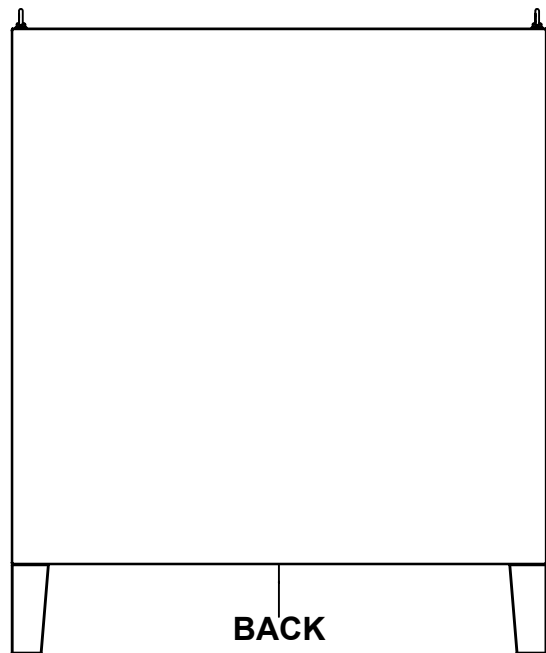

BACK

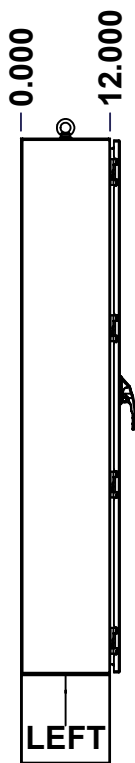

LEFT

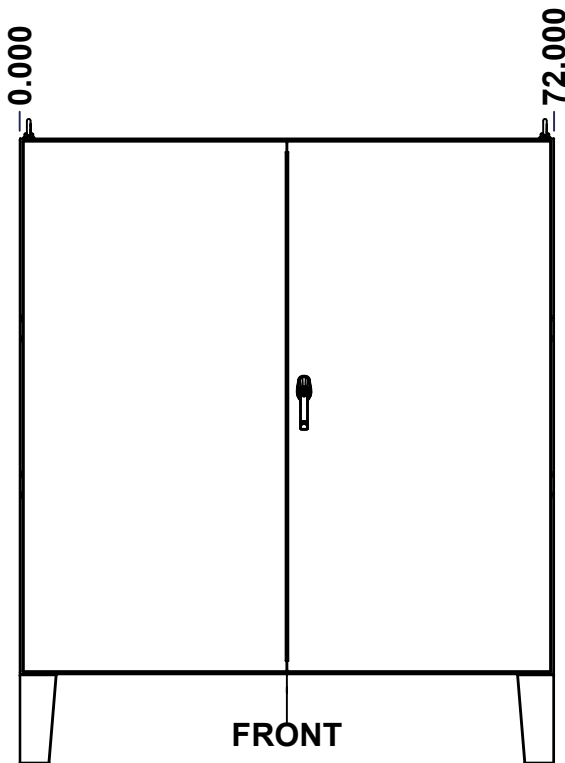

FRONT

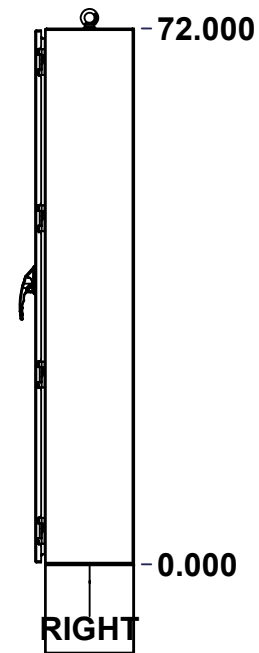

RIGHT



BOTTOM

No.	Revisions	Date	By/Par

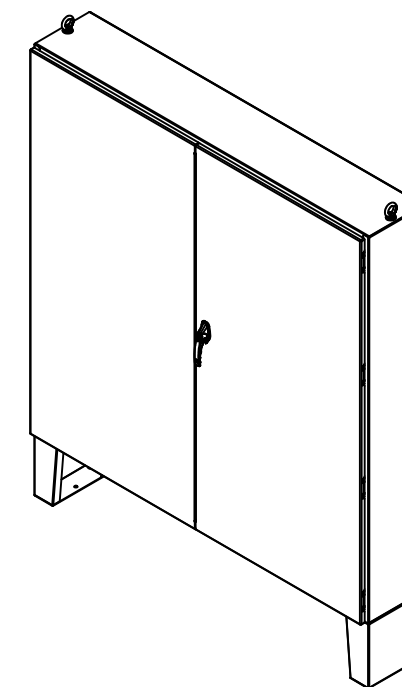

Isometric View



Tél: (450) 979-4373
 Fax: (450) 979-4626
www.exmweb.com

Flatness
Aplatissement

Max 3.0mm

Projection



Customer Client	Date
Drawn By Dessiné Par BoxCad: BoxCad	Date 10-Sep-14

Material
Matière 12 Ga Cold Rolled A1008 CS Type B (2.5mm)

Color
Couleur Asa-61 Grey

Finish
Fini Smooth

Description
5500DDS 72" x 72" x 12" Assembly

Detail Rev.

Part Number Numéro Pièce	Rev.	1
5500DDS727212	0	2

SEE BILL OF MATERIAL ON LAST PAGE

This drawing is confidential and must not be reproduced or used without the consent of EXM

Ce dessin est confidentiel et ne doit pas être reproduit ou utilisé sans le consentement de EXM

NOTE	
ITEM	DESCRIPTION
1	NEMA 12/13 Enclosure
2	C/W Standard ground studs on box and cover
3	C/W Standard door stiffener
4	C/W Standard inner panel (Included)
5	C/W Standard inner panel mounting studs
6	C/W Eyebolts
7	C/W Mounting feet sold separately (Installed)
8	C/W Struts installed (Included)

No.	Revisions	Date	By/Par

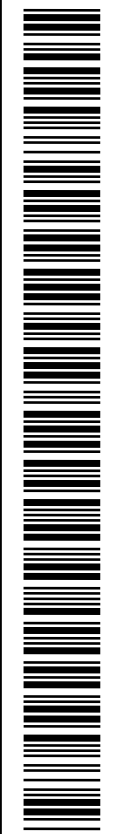
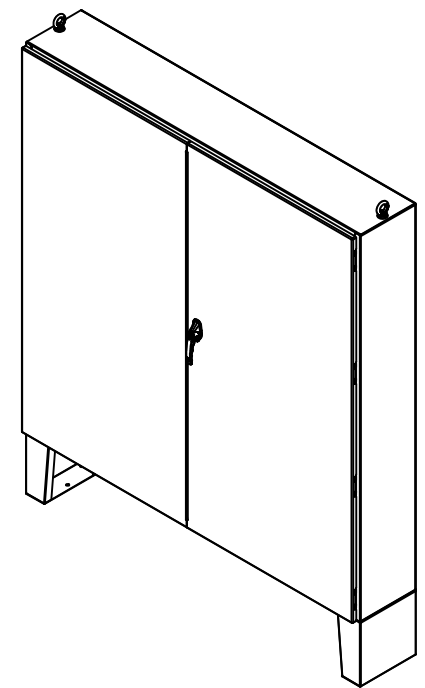

Isometric View

PACKING		
ITEM	QTY	DESCRIPTION
Cardboard sleeve	2	Top and Bottom
Cardboard strip	2	Between back of enclosure and inner panel
Plastic bag	1	To protect cover surface and inside gasket
Cardboard corner	4	To reinforced for the plastic strap tightening
Plastic strap - Black	2	To Squeeze 2 cardboard sleeve together
Packaging label	3	White label with PN
Plastic strap- Green	2	To secure the enclosure to the wood pallet
Wood Pallet	1	2" deeper and 3" larger than enclosure size

Qty	Part Number	Rev	Description
1	5500DDS727212MF	0	885 MFHD 12" x 12" Mounting Feet
1	880EB14	2	Eye Bolt M14 (Pack of 2)
8	STK-Q-07320	0	Flange Lock Nut M10
1	885SP7272G	0	885 SP7272G Inner Panel
6	STK-Q-07620	0	M10 Plastic Spacer 0.875"
1	5500DDS727212FD	0	5500DDS 72" x 72" Flange Door
1	5500DDS727212LD	0	5500DDS 72" x 72" Lock Door
1	5500DDS727212B	0	5500DDS 72" x 72" x 12" Body
2	5500DDS727212GP	0	5500DDS Gland Plate
8	STK-Q-04050-10	8	M6 x 10mm Hexagon Socket Head Machine Screw with Nyseal
Parts List			

	Tél: (450) 979-4373 Fax: (450) 979-4626 www.exmweb.com	Flatness	Max 3.0mm
		Aplatissement	Projection
Customer		Date	
Client		Date 10-Sep-14	
Drawn By	BoxCad: BoxCad	Date	
Dessiné Par			
Material	12 Ga Cold Rolled A1008 CS Type B (2.5mm)		
Matière			
Color	Asa-61 Grey	Finish	Smooth
Couleur		Fini	
Description		Detail Rev.	
5500DDS 72" x 72" x 12" Assembly			
Part Number		Rev.	2
Numéro Pièce		0	2
5500DDS727212			

This drawing is confidential and must not be reproduced or used without the consent of EXM

Ce dessin est confidentiel et ne doit pas être reproduit ou utilisé sans le consentement de EXM

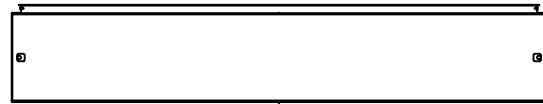

TOP

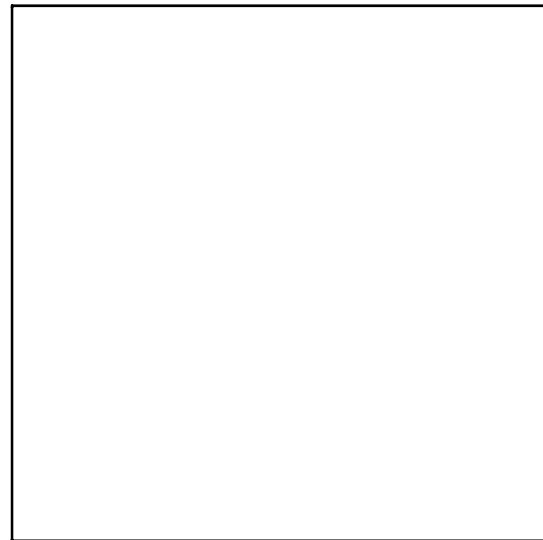

BACK

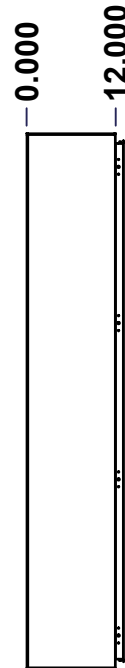

LEFT

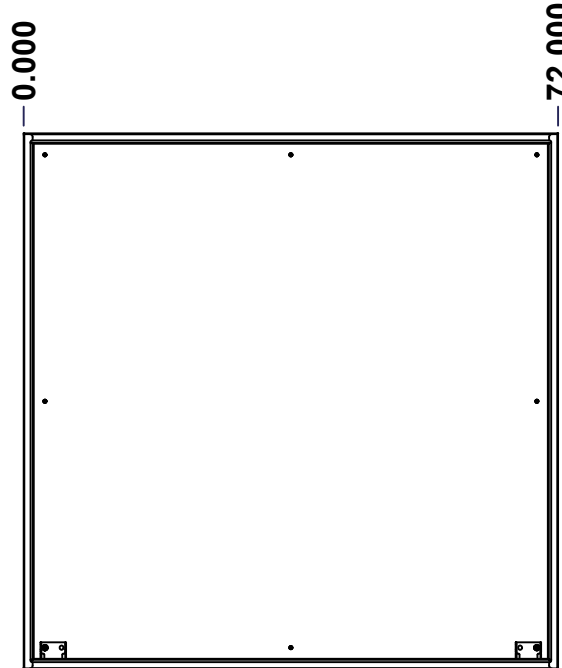

FRONT

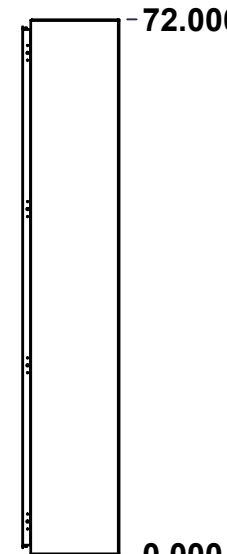

RIGHT

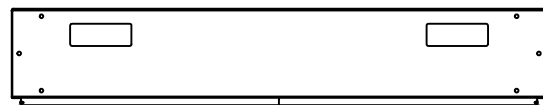

BOTTOM

No.	Revisions	Date	By/Par

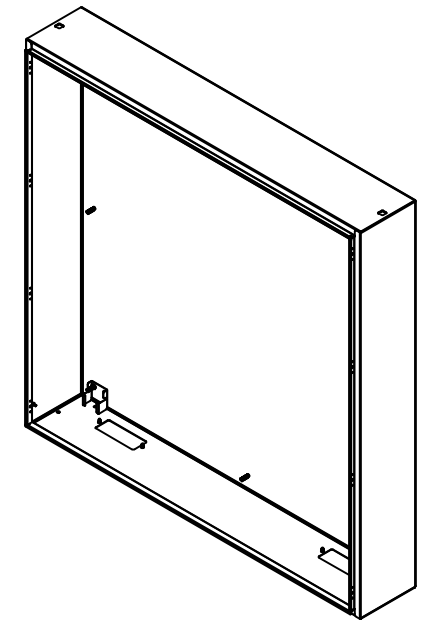

Isometric View



Tél: (450) 979-4373
 Fax: (450) 979-4626
www.exmweb.com

Flatness
Aplatissement

Max 3.0mm

Projection



Customer Client	Date
Drawn By / Dessiné Par: BoxCad: BoxCad	Date: 10-Sep-14

Material / Matière: 12 Ga Cold Rolled A1008 CS Type B (2.5mm)

Color / Couleur: Asa-61 Grey	Finish / Fini: Smooth
------------------------------	-----------------------

Description: 5500DDS 72" x 72" x 12" Body	Detail Rev.
---	-------------

Part Number / Numéro Pièce: 5500DDS727212B	Rev. 1	2
	0	

SEE BILL OF MATERIAL ON LAST PAGE

This drawing is confidential and must not be reproduced or used without the consent of EXM

Ce dessin est confidentiel et ne doit pas être reproduit ou utilisé sans le consentement de EXM

STANDARD FEATURES ARE NOT LISTED IN THIS HOLE TABLE

HOLE TABLE - TOP VIEW (CUSTOM FEATURE ONLY)

CUT-OUT	XDIM	YDIM	DESCRIPTION
1	53.911	7.911	Struts CR400 27.500" (Inside)
2	17.911	7.911	Struts CR400 27.500" (Inside)
3	53.911	7.911	STUDS M6 x 10mm (Inside)
4	43.161	7.911	STUDS M6 x 10mm (Inside)
5	64.661	7.911	STUDS M6 x 10mm (Inside)
6	17.911	7.911	STUDS M6 x 10mm (Inside)
7	7.161	7.911	STUDS M6 x 10mm (Inside)
8	28.661	7.911	STUDS M6 x 10mm (Inside)

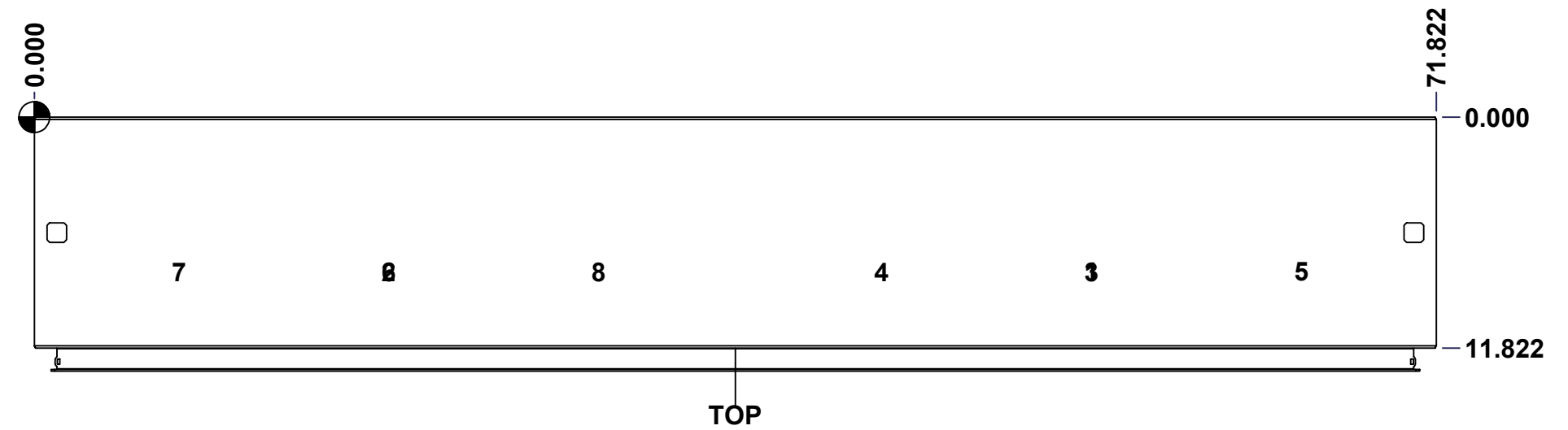

	Description	Status	
	5500DDS 72" x 72" x 12" Body	Released	
	Part Number Numéro Pièce	Rev.	
	5500DDS727212B	0	2 / 7

This drawing is confidential and must not be reproduced or used without the consent of EXM

Ce dessin est confidentiel et ne doit pas être reproduit ou utilisé sans le consentement de EXM

STANDARD FEATURES ARE NOT LISTED IN THIS HOLE TABLE			
HOLE TABLE - RIGHT VIEW (CUSTOM FEATURE ONLY)			
CUT-OUT	XDIM	YDIM	DESCRIPTION
1	10.411	3.286	GND STUD M6 x 16mm (Inside)

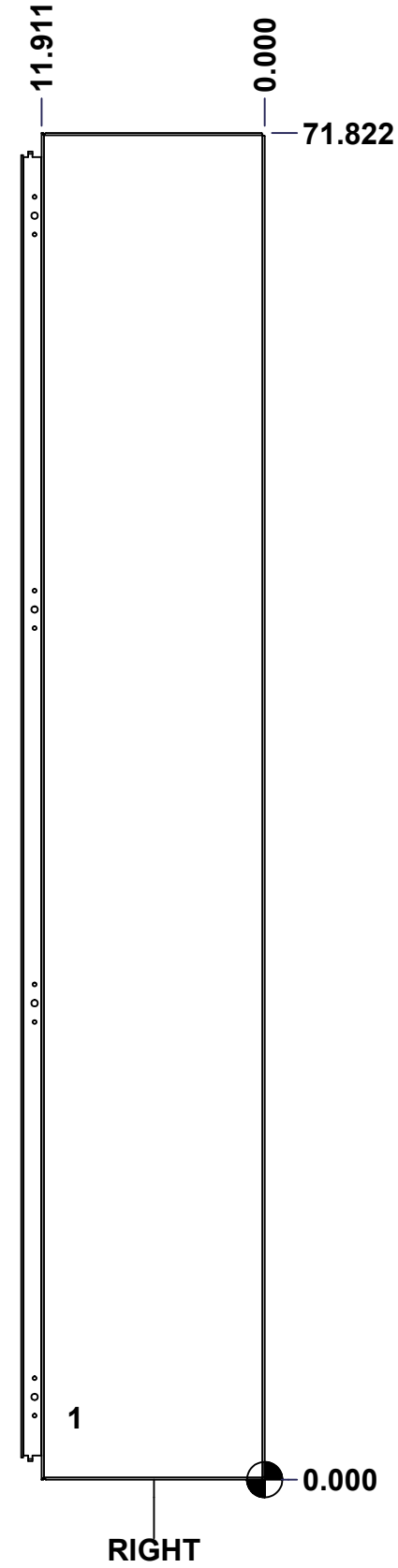

	Description	Status
	5500DDS 72" x 72" x 12" Body	Released
	Part Number Numéro Pièce	Rev.
	5500DDS727212B	0
		3
		7

This drawing is confidential and must not be reproduced or used without the consent of EXM

Ce dessin est confidentiel et ne doit pas être reproduit ou utilisé sans le consentement de EXM

STANDARD FEATURES ARE NOT LISTED IN THIS HOLE TABLE

HOLE TABLE - BOTTOM VIEW (CUSTOM FEATURE ONLY)

CUT-OUT	XDIM	YDIM	DESCRIPTION
1	7.286	3.411	GP STUD M6 x 16mm (Inside)
2	16.536	3.411	GP STUD M6 x 16mm (Inside)
3	55.286	3.411	GP STUD M6 x 16mm (Inside)
4	64.536	3.411	GP STUD M6 x 16mm (Inside)

5	3.911	0.911	RND Ø0.500
6	0.911	5.911	RND Ø0.500
7	3.911	10.911	RND Ø0.500
8	67.911	0.911	RND Ø0.500
9	70.911	5.911	RND Ø0.500
10	67.911	10.911	RND Ø0.500

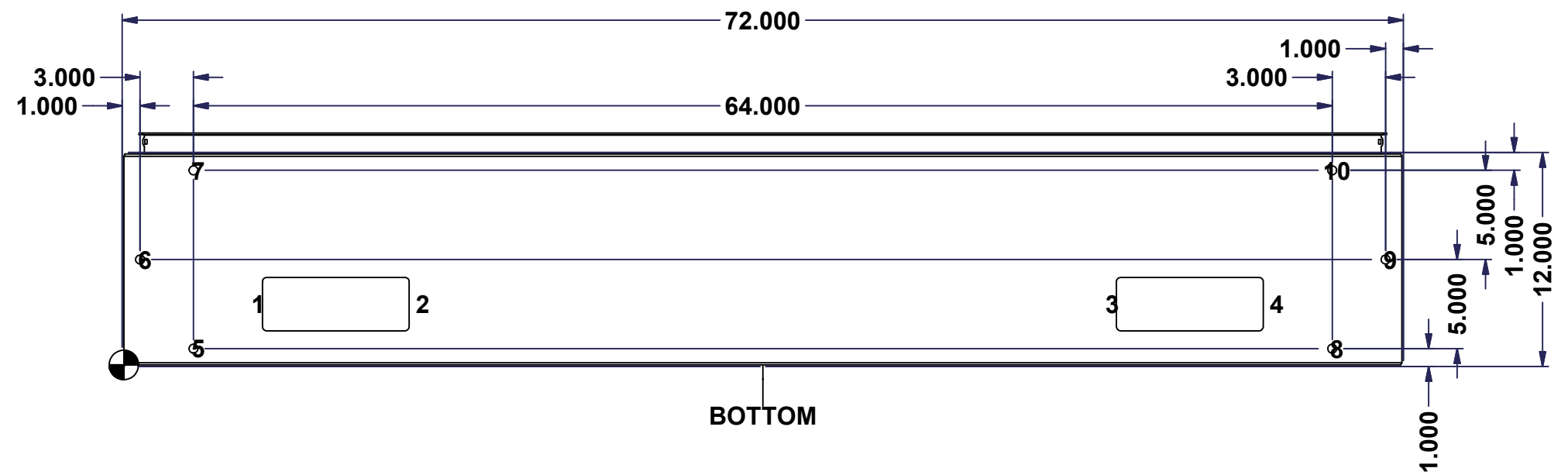

	Description	Status	
	5500DDS 72" x 72" x 12" Body	Released	
	Part Number Numéro Pièce	Rev.	
	5500DDS727212B	0	4 / 7

This drawing is confidential and must not be reproduced or used without the consent of EXM

Ce dessin est confidentiel et ne doit pas être reproduit ou utilisé sans le consentement de EXM

STANDARD FEATURES ARE NOT LISTED IN THIS HOLE TABLE			
HOLE TABLE - LEFT VIEW (CUSTOM FEATURE ONLY)			
CUT-OUT	XDIM	YDIM	DESCRIPTION
1	10.411	3.286	GND STUD M6 x 16mm (Inside)

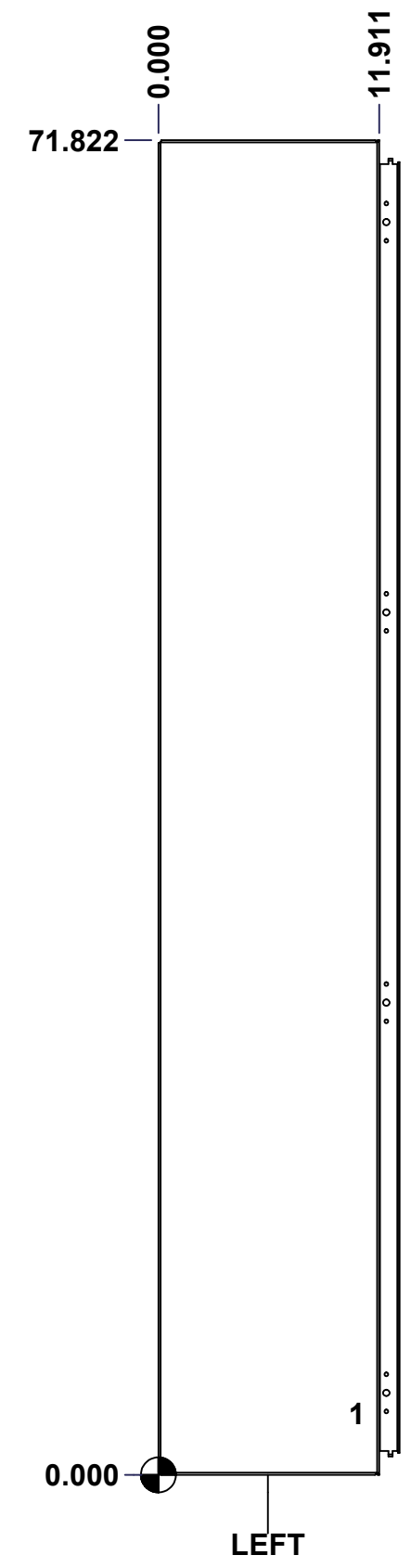

	Description	Status	
	5500DDS 72" x 72" x 12" Body	Released	
	Part Number Numéro Pièce	Rev.	5
	5500DDS727212B	0	7

This drawing is confidential and must not be reproduced or used without the consent of EXM

Ce dessin est confidentiel et ne doit pas être reproduit ou utilisé sans le consentement de EXM

STANDARD FEATURES ARE NOT LISTED IN THIS HOLE TABLE

HOLE TABLE - BACK VIEW (CUSTOM FEATURE ONLY)

CUT-OUT	XDIM	YDIM	DESCRIPTION
1	2.786	2.786	IP STUD M10 x 40mm (Inside)
2	69.036	2.786	IP STUD M10 x 40mm (Inside)
3	2.786	35.911	IP STUD M10 x 40mm (Inside)
4	69.036	35.911	IP STUD M10 x 40mm (Inside)
5	2.786	69.036	IP STUD M10 x 40mm (Inside)
6	69.036	69.036	IP STUD M10 x 40mm (Inside)
7	35.911	2.786	IP STUD M10 x 40mm (Inside)
8	35.911	69.036	IP STUD M10 x 40mm (Inside)

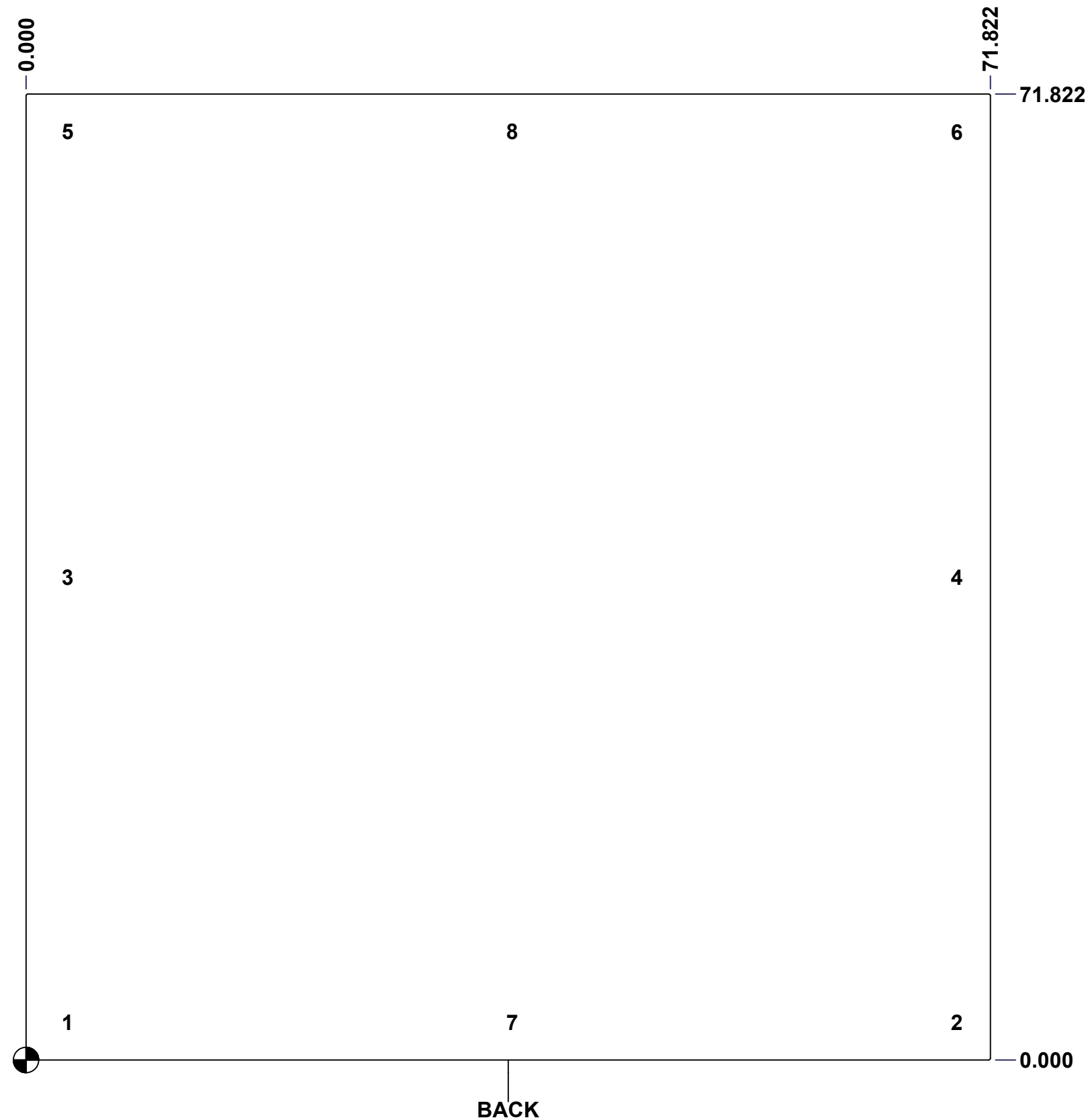

	Description	Status
	5500DDS 72" x 72" x 12" Body	Released
	Part Number Numéro Pièce	Rev.
	5500DDS727212B	0
		6
		7

This drawing is confidential and must not be reproduced or used without the consent of EXM

Ce dessin est confidentiel et ne doit pas être reproduit ou utilisé sans le consentement de EXM

No.	Revisions	Date	By/Par

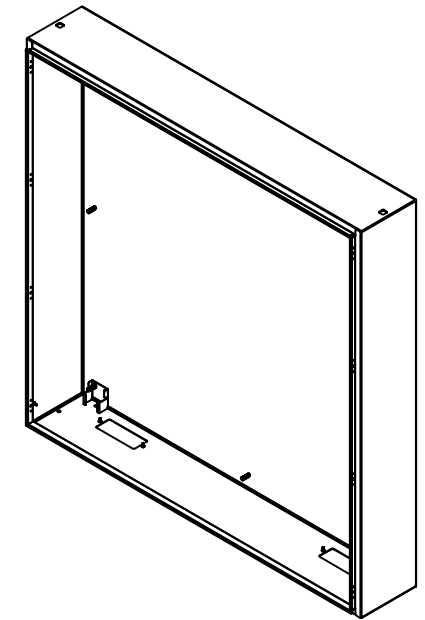

Isometric View

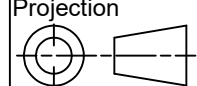

6	STK-Q-16030	0	Stud M6 x 10mm
6	STK-Q-07220	1	M6 Nylon Insert Lock Nut
1	STK-P-02400S	0	Powder Paint (Asa-61 Grey / Smooth)
2	STK-Q-07320	0	Flange Lock Nut M10
2	STK-Q-07618	1	5500 Series Inner Panel Support Bracket
8	STK-Q-16100	0	Stud M10 x 40mm
1	5500DDS727212BT-P	0	5500DDS 72" x 12" Bottom Part
1	5500DDS727212T-P	0	5500DDS 72" x 12" Top Part
1	5500DDS727212RS-P	0	5500DDS 72" x 72" Right Part
1	5500DDS727212LS-P	0	5500DDS 72" x 72" Left Part
1	5500DDS727212B-P	0	5500DDS 72" x 72" Back Part
2	CR400MS_27.5	0	Commercial Roll Mild Steel (27.5in long)
6	STK-Q-16080	0	Ground Stud M6 x 16mm
Qty	Part Number	Rev	Description
Parts List			

 Tél: (450) 979-4373 Fax: (450) 979-4626 www.exmweb.com		Flatness Aplatissement Max 3.0mm Projection 
Customer Client	Date	Date 10-Sep-14
Drawn By Dessiné Par	BoxCad: BoxCad	
Material Matière	12 Ga Cold Rolled A1008 CS Type B (2.5mm)	
Color Couleur	Asa-61 Grey	Finish Fini Smooth
Description	5500DDS 72" x 72" x 12" Body	
Part Number Numéro Pièce	Rev.	2
5500DDS727212B	0	2

This drawing is confidential and must not be reproduced or used without the consent of EXM

Ce dessin est confidentiel et ne doit pas être reproduit ou utilisé sans le consentement de EXM

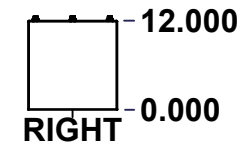
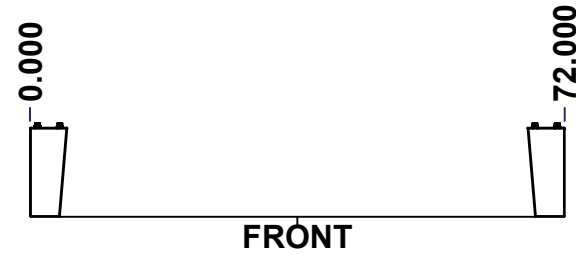
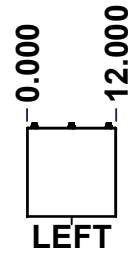
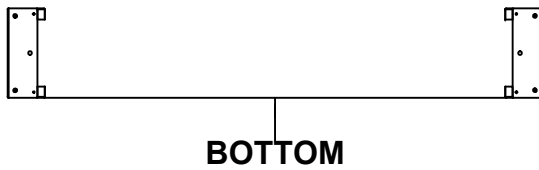
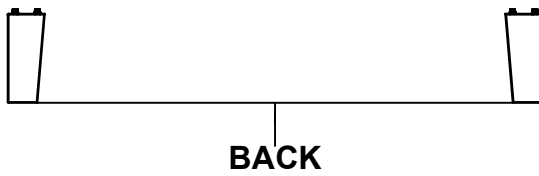
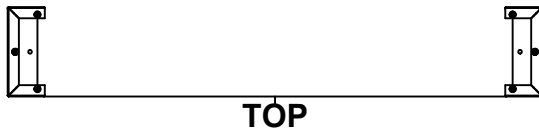

No.	Revisions	Date	By/Par

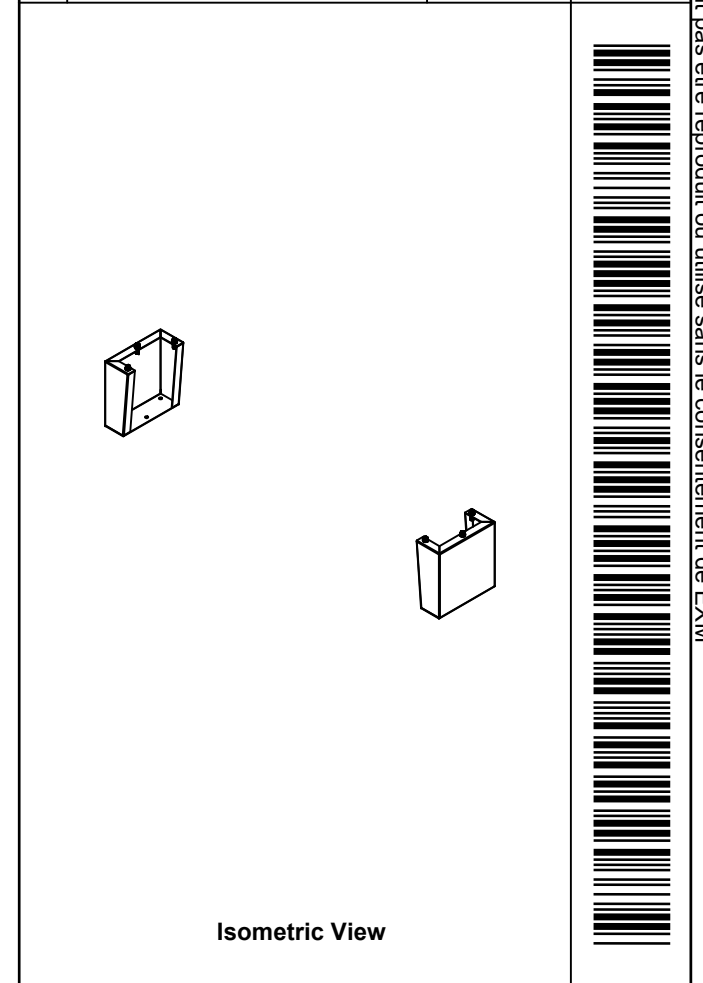

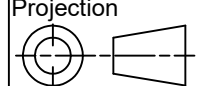
 Tél: (450) 979-4373 Fax: (450) 979-4626 www.exmweb.com		Flatness Aplatissement Max 3.0mm Projection 
Customer Client	Date	
Drawn By Dessiné Par	BoxCad: BoxCad	Date 10-Sep-14
Material Matière	12 Ga Cold Rolled A1008 CS Type B (2.5mm)	
Color Couleur	Asa-61 Grey	Finish Fini Smooth
Description 885 MFHD 12" x 12" Mounting Feet		Detail Rev.
Part Number Numéro Pièce	Rev. 0	1/4

SEE BILL OF MATERIAL ON LAST PAGE

5500DDS727212MF

This drawing is confidential and must not be reproduced or used without the consent of EXM

Ce dessin est confidentiel et ne doit pas être reproduit ou utilisé sans le consentement de EXM

No.	Revisions	Date	By/Par

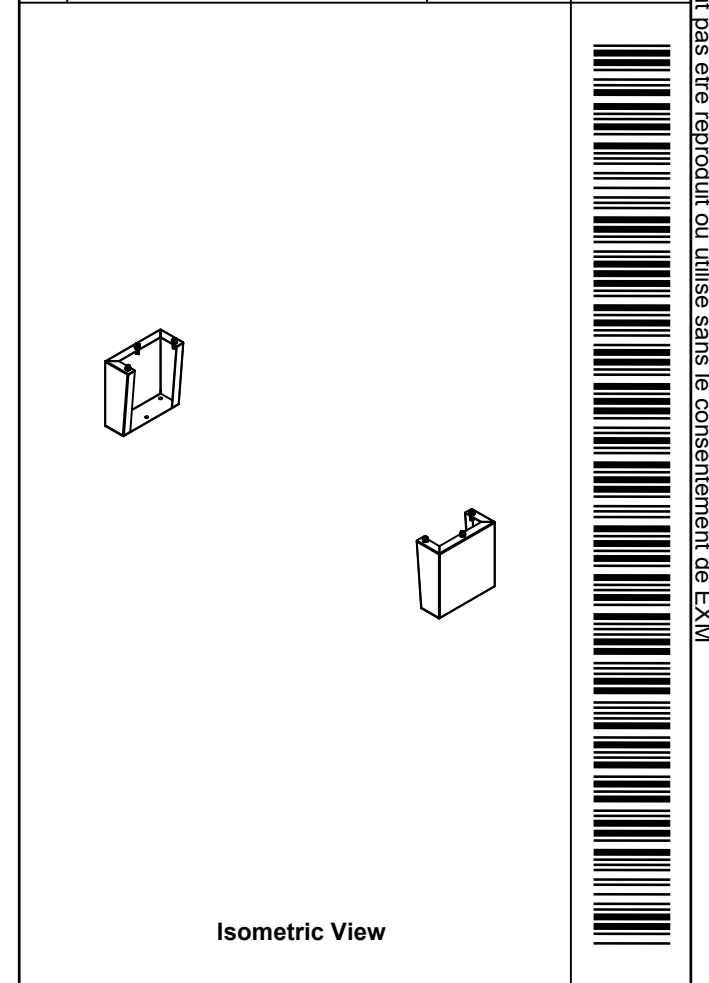

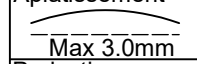
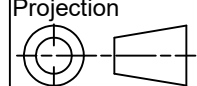
 Tél: (450) 979-4373 Fax: (450) 979-4626 www.exmweb.com		Flatness Aplatissement  Max 3.0mm Projection 
Customer Client	Date	
Drawn By Dessiné Par	BoxCad: BoxCad	Date 10-Sep-14
Material Matière	12 Ga Cold Rolled A1008 CS Type B (2.5mm)	
Color Couleur	Asa-61 Grey	Finish Fini Smooth
Description		Detail Rev.
885 MFHD 12" x 12" Mounting Feet		
Part Number Numéro Pièce	Rev.	4
5500DDS727212MF	0	4

Qty	Part Name	Rev	Description
1	STK-P-02400S	0	Powder Paint (Asa-61 Grey / Smooth)
6	RIVET_NUT_M10_FH_CE	0	Rivet Nut M10 (Low Profile Close End)
1	5500DDS727212MFR-P	0	885 MFHD 12" x 12" Right Mounting Feet Part
1	5500DDS727212MFL-P	0	885 MFHD 12" x 12" Left Mounting Feet Part
1	STK-K-11600	2	885 MF Accessory Kit
Parts List			

This drawing is confidential and must not be reproduced or used without the consent of EXM

Ce dessin est confidentiel et ne doit pas être reproduit ou utilisé sans le consentement de EXM

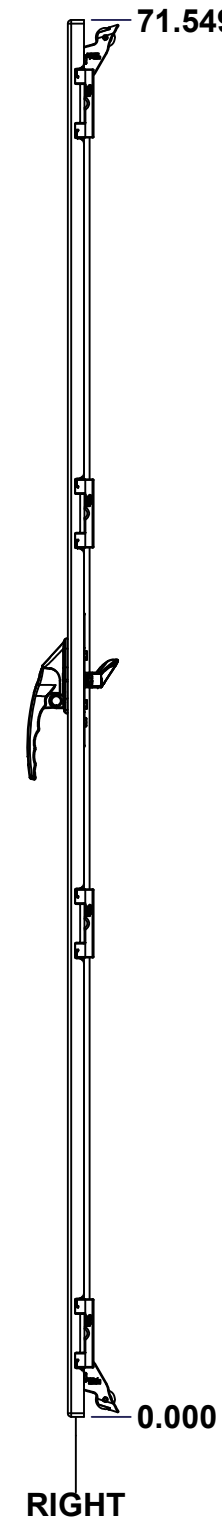
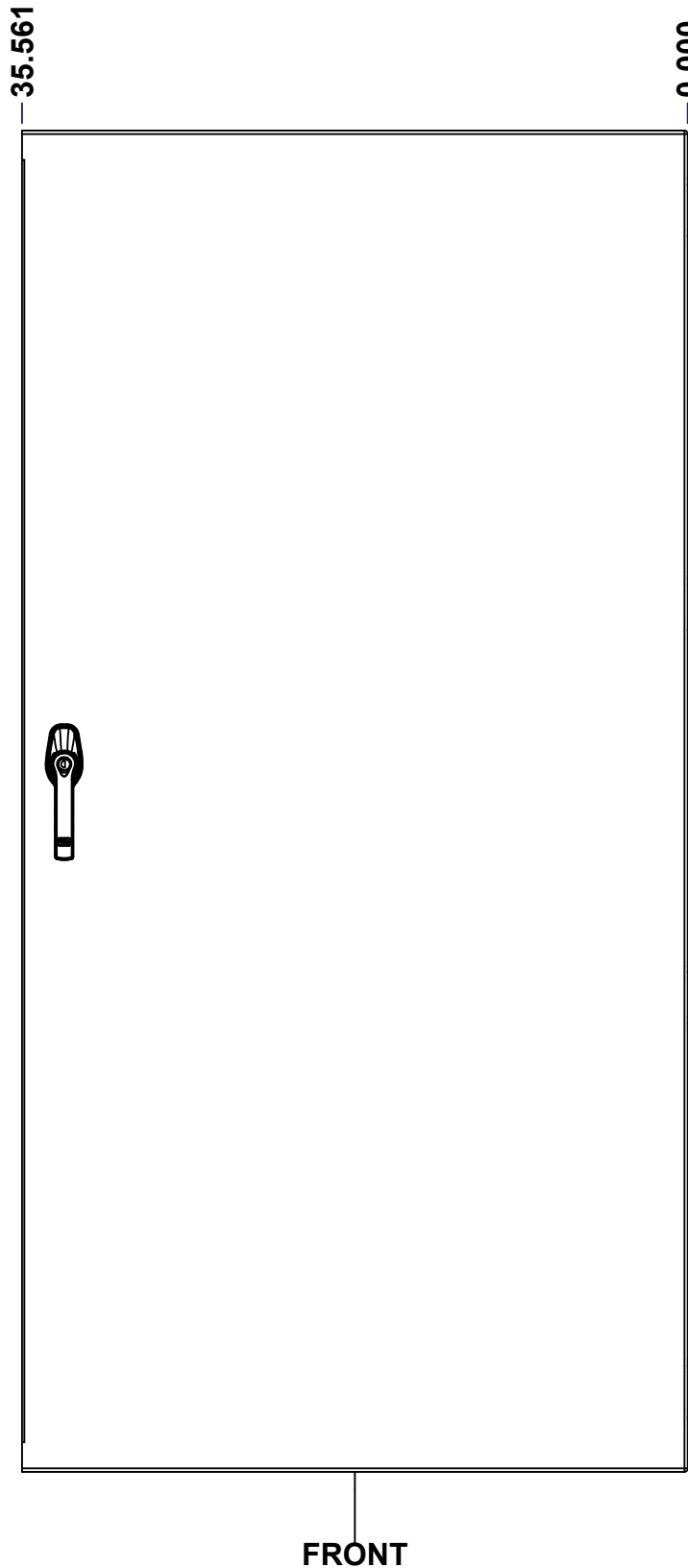
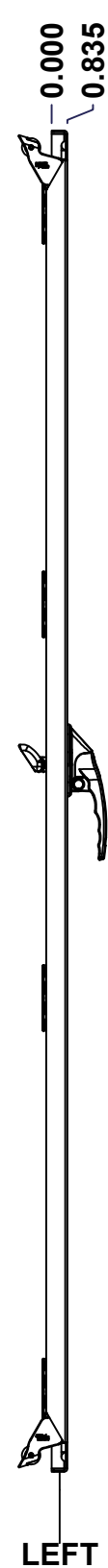
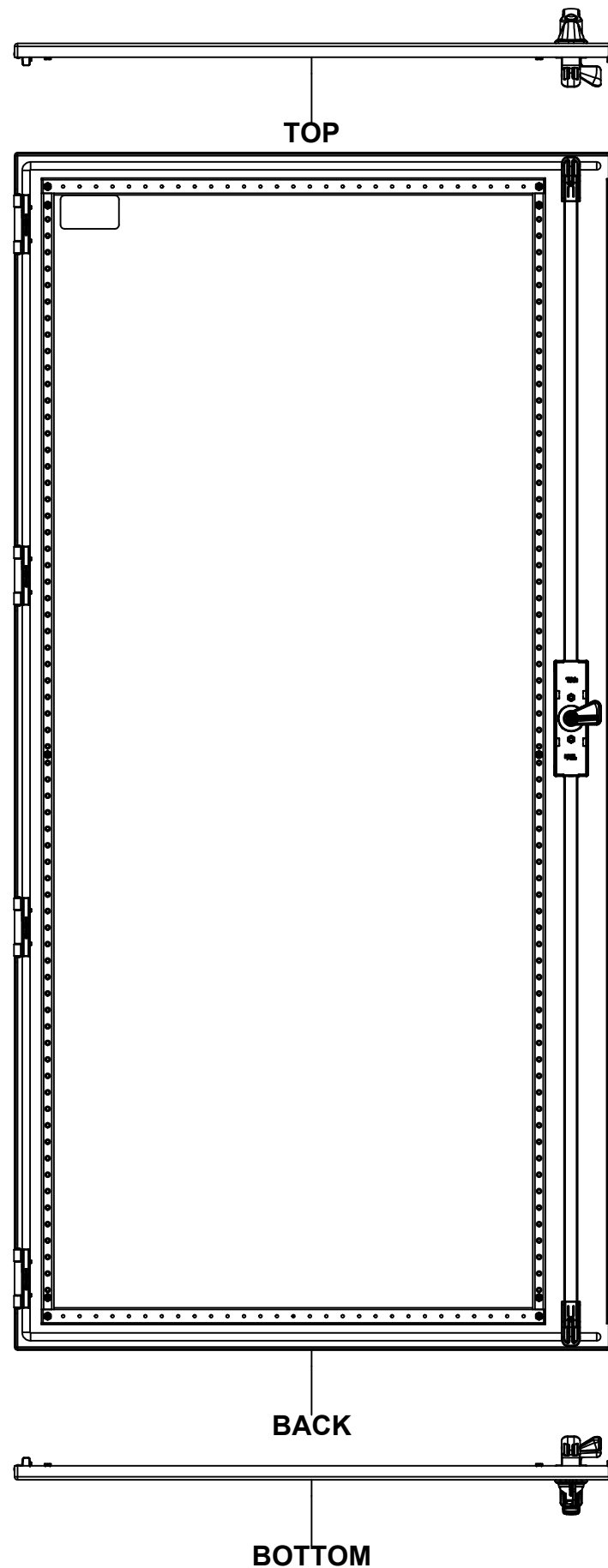

No.	Revisions	Date	By/Par

Isometric View

Tél: (450) 979-4373 Fax: (450) 979-4626 www.exmweb.com		Flatness Aplatissement	
		Max 3.0mm	
Customer Client		Projection	
Date			
Drawn By Dessiné Par BoxCad: BoxCad		Date 10-Sep-14	
Material Matière 12 Ga Cold Rolled A1008 CS Type B (2.5mm)			
Color Couleur Asa-61 Grey		Finish Fini Smooth	
Description 5500DDS 72" x 72" Lock Door			Detail Rev.
Part Number Numéro Pièce 5500DDS727212LD		Rev. 0	1 / 3

SEE BILL OF MATERIAL ON LAST PAGE

This drawing is confidential and must not be reproduced or used without the consent of EXM

Ce dessin est confidentiel et ne doit pas être reproduit ou utilisé sans le consentement de EXM

STANDARD FEATURES ARE NOT LISTED IN THIS HOLE TABLE

HOLE TABLE - FRONT VIEW (CUSTOM FEATURE ONLY)

CUT-OUT	XDIM	YDIM	DESCRIPTION
1	1.983	2.028	STUD M6 x 18mm (Inside)
2	1.983	35.580	STUD M6 x 18mm (Inside)
3	1.983	69.521	STUD M6 x 18mm (Inside)
4	1.983	3.139	STUD M6 x 18mm (Inside)
5	1.983	68.409	STUD M6 x 18mm (Inside)
6	31.390	2.028	STUD M6 x 18mm (Inside)
7	31.390	35.580	STUD M6 x 18mm (Inside)
8	31.390	69.521	STUD M6 x 18mm (Inside)
9	31.390	3.139	STUD M6 x 18mm (Inside)
10	31.390	68.409	STUD M6 x 18mm (Inside)
11	33.311	6.118	STUD M6 x 18mm (Inside)
12	33.311	65.430	STUD M6 x 18mm (Inside)
-----	-----	-----	-----
13	33.311	37.743	HANDLE 885 ESL2A-APHK @ 0.0°

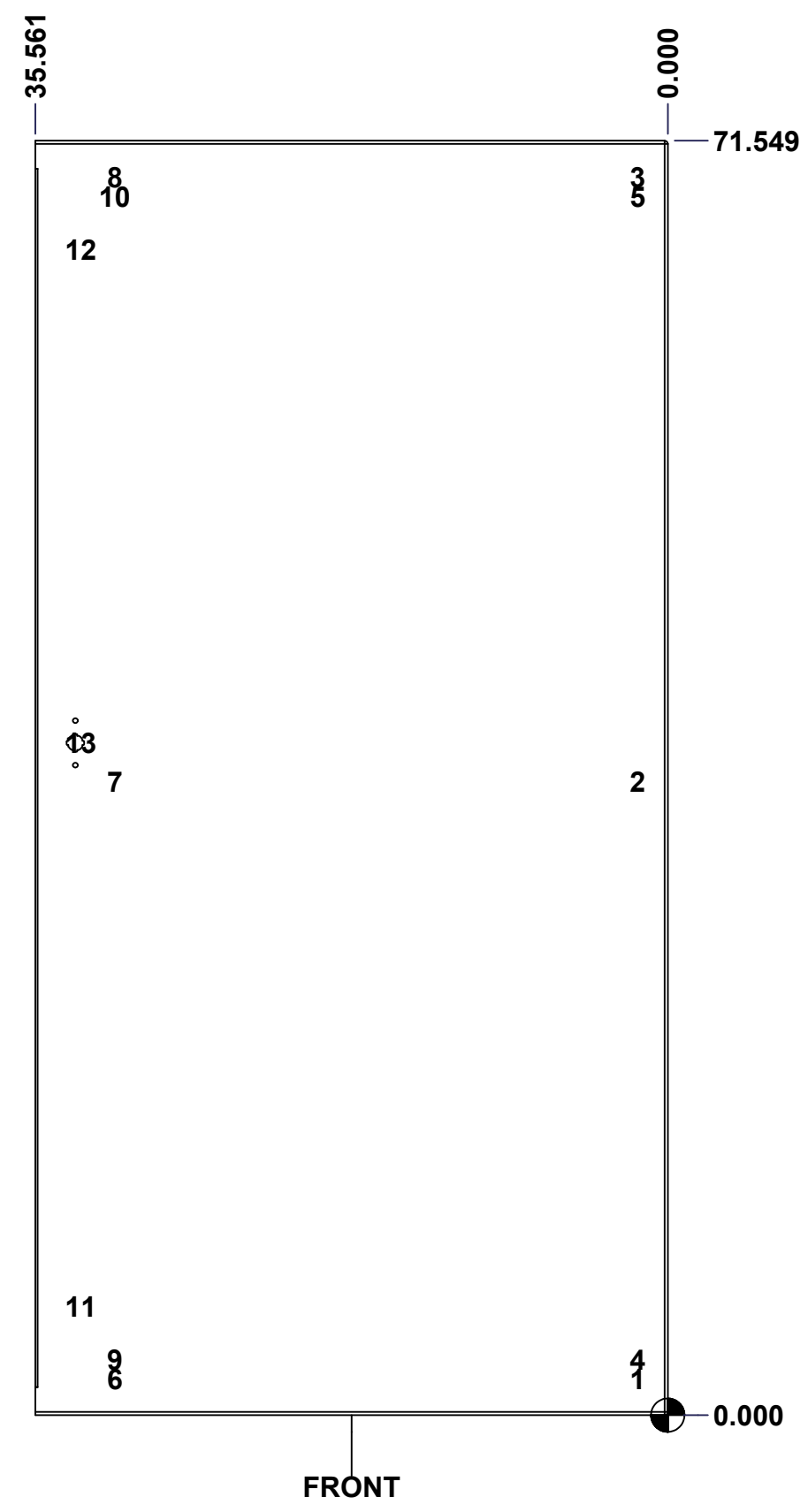

	Description	Status
	5500DDS 72" x 72" Lock Door	(NULL)
	Part Number Numéro Pièce	Rev.
	5500DDS727212LD	0
		2
		3

This drawing is confidential and must not be reproduced or used without the consent of EXM

Ce dessin est confidentiel et ne doit pas être reproduit ou utilisé sans le consentement de EXM

No.	Revisions	Date	By/Par

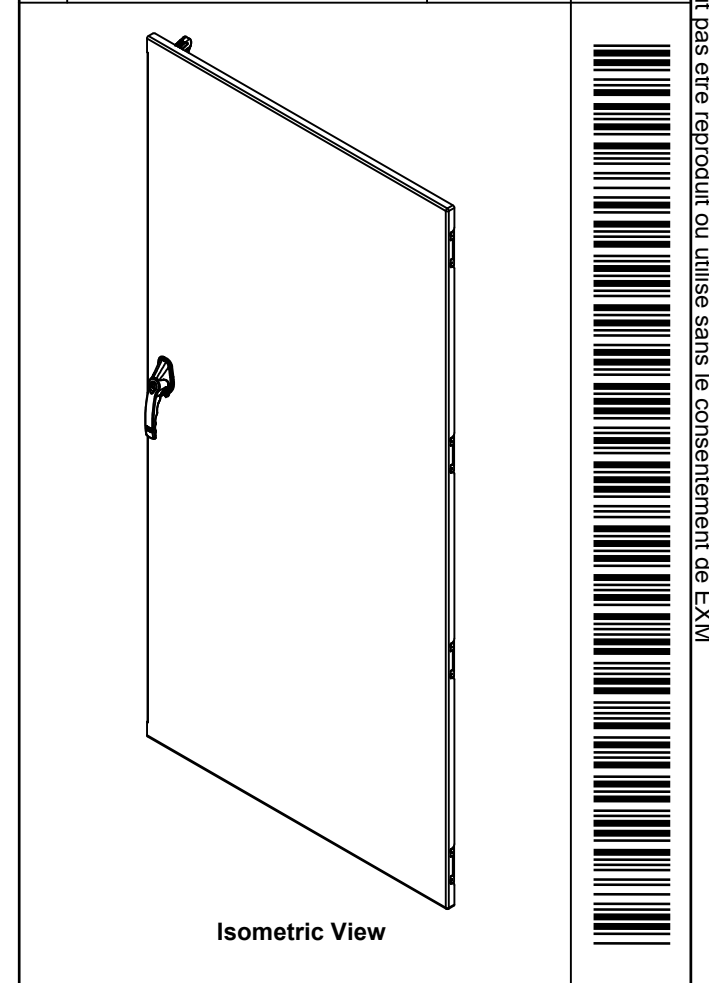

Qty	Part Name	Rev	Description
1	STK-Q-47522	1	5500 DDS Lower Closing Bar 72"
1	STK-Q-47512	0	5500 DDS Upper Closing Bar 72"
1	STK-A-03986-36	2	Gearbox Counterclockwise Assembly (36.0mm)
1	885ESL2A-APHK	6	885 ESL2A-APHK - Zinc Die Cast L-Handle Padlockable Assy
1	STK-P-02400S	0	Powder Paint (Asa-61 Grey / Smooth)
1	STK-S-00100	0	3.5" x 2" Silver Milar Flexcon Sticker
1	5500DDS727212LDG	0	5500DDS 72" x 72" Lock Door Gasket
1	STK-K-10730	3	5500 DDS - Door Stiffener Assembly
2	STK-Q-16410	0	Guide Stud - Largel (No Paint Cap Required)
10	STK-Q-16055	1	M6 x 18mm Stud (No Paint Cap Required)
1	5500DDS727212LD-P	0	5500DDS 72" x 72" Lock Door Part
4	STK-K-09860	7	Cabinet Hinge with Captive Pins
2	STK-A-90025	0	9500 - Cabinet Closing Bar End (Large)
Qty	Part Name	Rev	Description
Parts List			

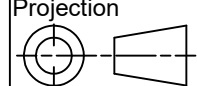
 Tél: (450) 979-4373 Fax: (450) 979-4626 www.exmweb.com		Flatness Aplatissement Max 3.0mm Projection 
Customer Client	Date	Date
Drawn By Dessiné Par	BoxCad: BoxCad	Date 10-Sep-14
Material Matière	12 Ga Cold Rolled A1008 CS Type B (2.5mm)	
Color Couleur	Asa-61 Grey	Finish Fini Smooth
Description	5500DDS 72" x 72" Lock Door	
Part Number Numéro Pièce	Rev.	3
5500DDS727212LD	0	3

This drawing is confidential and must not be reproduced or used without the consent of EXM

Ce dessin est confidentiel et ne doit pas être reproduit ou utilisé sans le consentement de EXM



TOP

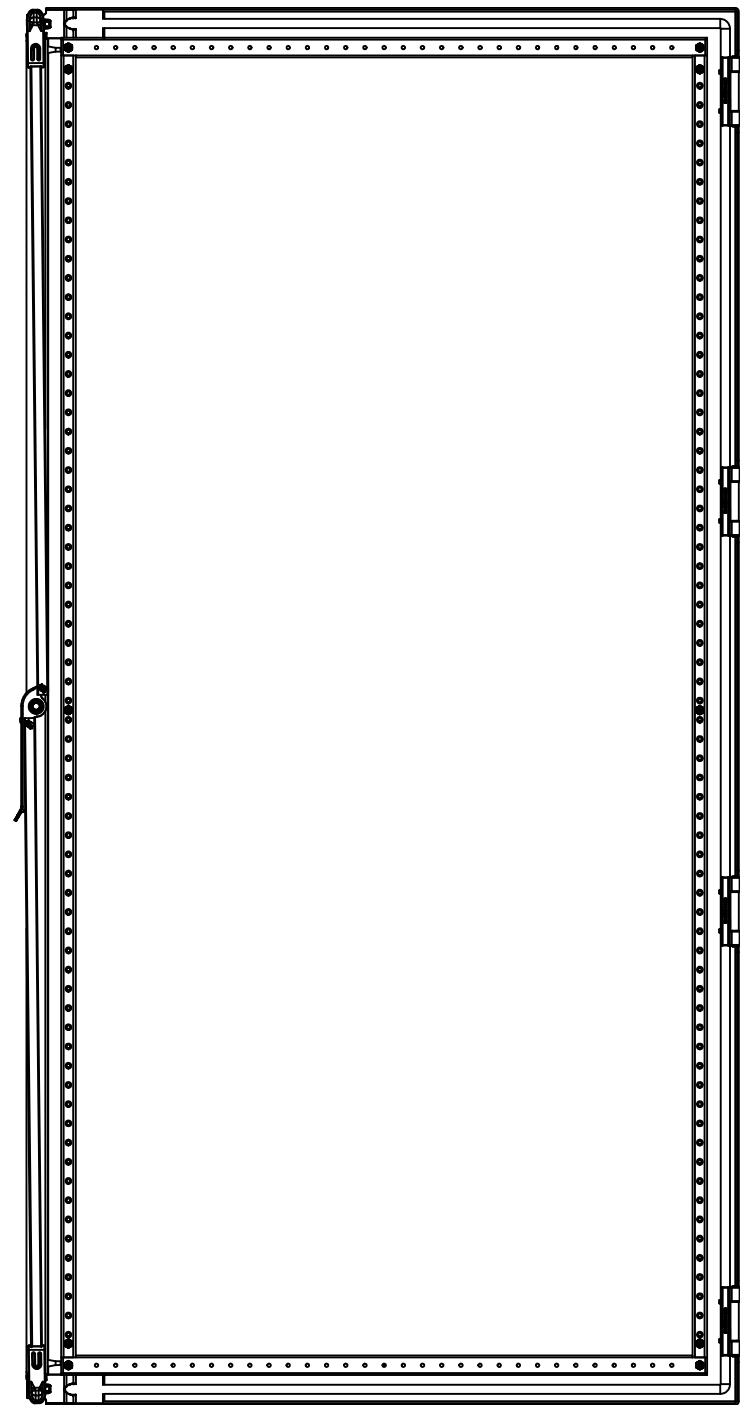

BACK

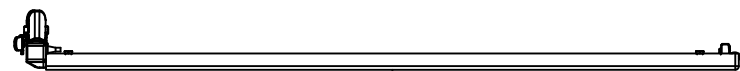

BOTTOM

0.000
0.835



LEFT

0.000
35.561

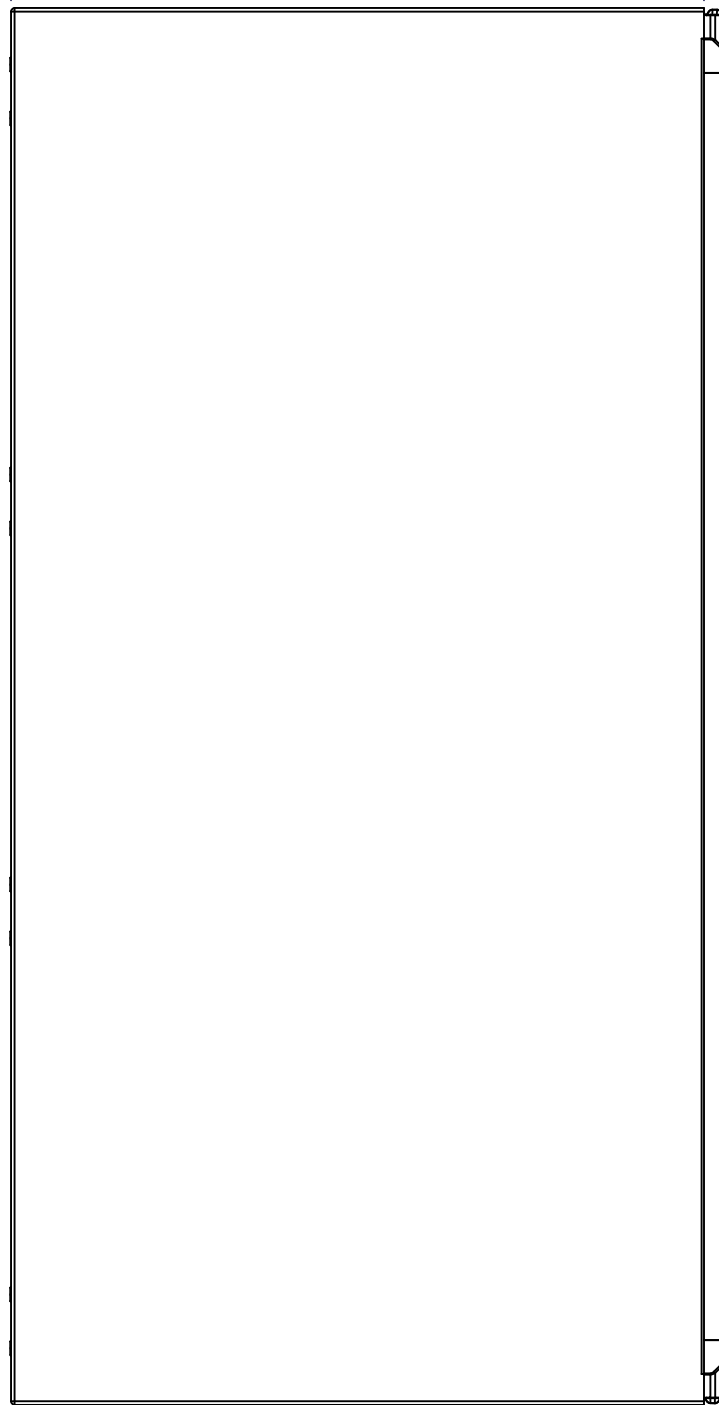

FRONT

71.549

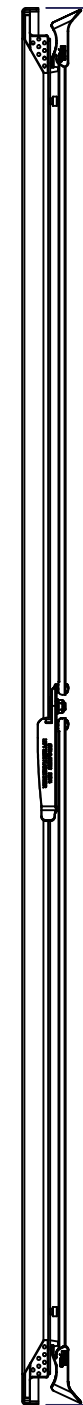

RIGHT

0.000

No.	Revisions	Date	By/Par

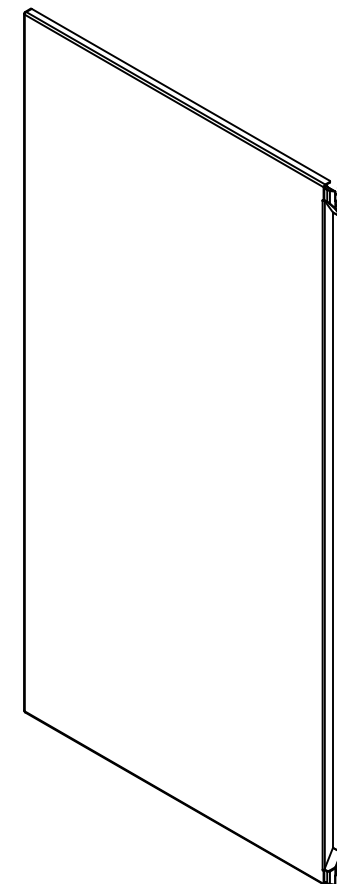

Isometric View



Tél: (450) 979-4373
Fax: (450) 979-4626
www.exmweb.com

Flatness
Aplatissement

Max 3.0mm

Projection

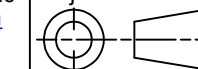

Customer Client	Date
Drawn By Dessiné Par	Date

BoxCad: BoxCad
10-Sep-14

Material
Matière 12 Ga Cold Rolled A1008 CS Type B (2.5mm)

Color
Couleur Asa-61 Grey

Finish
Fini Smooth

Description
5500DDS 72" x 72" Flange Door

Detail Rev.

Part Number
Numéro Pièce **5500DDS727212FD**

Rev.	1
0	3

SEE BILL OF MATERIAL ON LAST PAGE

This drawing is confidential and must not be reproduced or used without the consent of EXM

Ce dessin est confidentiel et ne doit pas être reproduit ou utilisé sans le consentement de EXM

STANDARD FEATURES ARE NOT LISTED IN THIS HOLE TABLE

HOLE TABLE - FRONT VIEW (CUSTOM FEATURE ONLY)

CUT-OUT	XDIM	YDIM	DESCRIPTION
1	2.000	2.028	STUD M6 x 18mm (Inside)
2	2.000	35.580	STUD M6 x 18mm (Inside)
3	2.000	69.521	STUD M6 x 18mm (Inside)
4	2.000	3.139	STUD M6 x 18mm (Inside)
5	2.000	68.409	STUD M6 x 18mm (Inside)
6	34.407	2.028	STUD M6 x 18mm (Inside)
7	34.407	35.580	STUD M6 x 18mm (Inside)
8	34.407	69.521	STUD M6 x 18mm (Inside)
9	34.407	3.139	STUD M6 x 18mm (Inside)
10	34.407	68.409	STUD M6 x 18mm (Inside)
11	36.061	4.774	CLOSING BAR GUIDE (Inside)
12	36.061	66.774	CLOSING BAR GUIDE (Inside)
13	36.061	35.774	STUD M10 x 20mm (Inside)

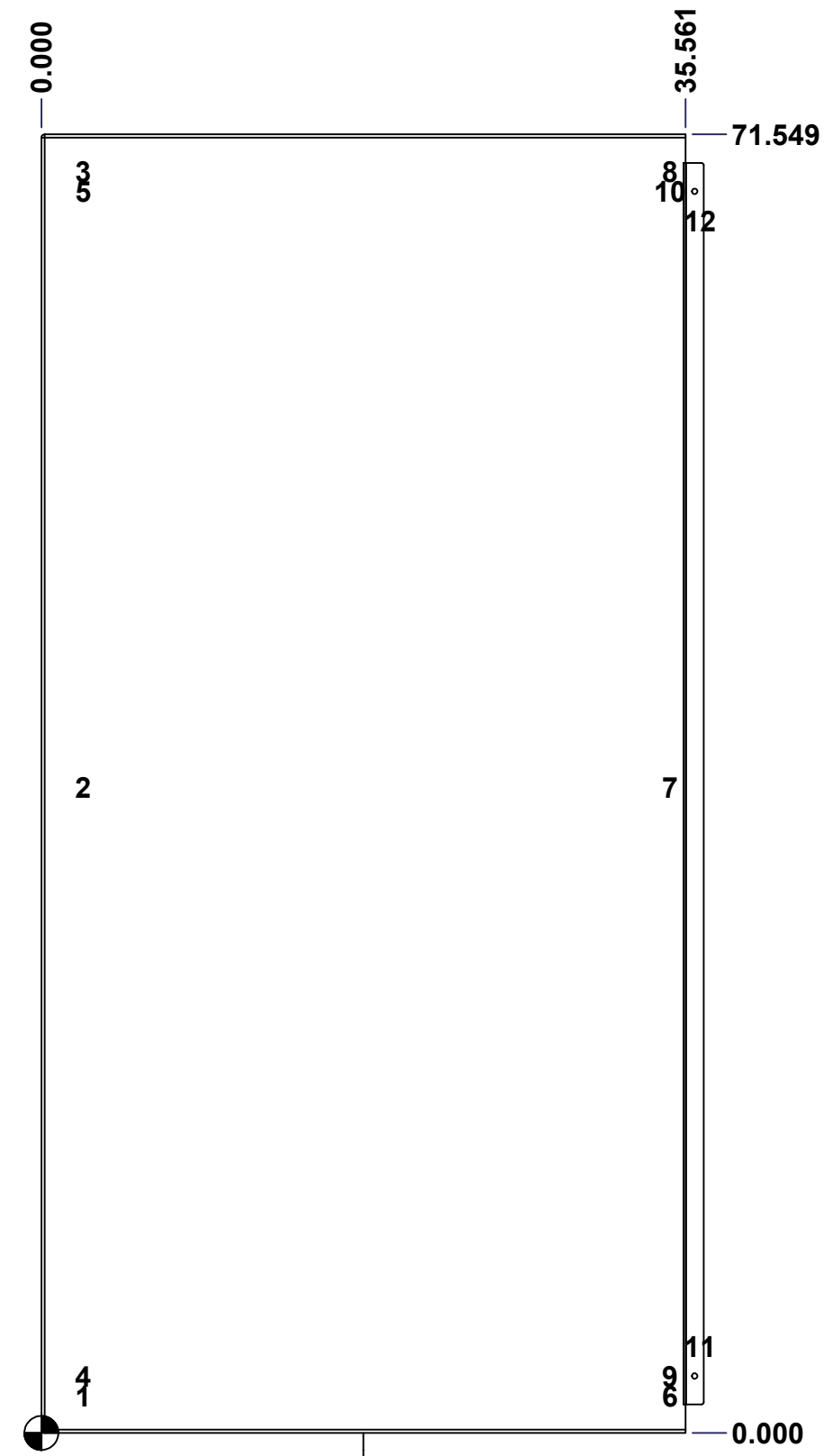

FRONT

	Description	Status	
	5500DDS 72" x 72" Flange Door	(NULL)	
	Part Number Numéro Pièce	Rev.	
	5500DDS727212FD	0	2 3

This drawing is confidential and must not be reproduced or used without the consent of EXM

Ce dessin est confidentiel et ne doit pas être reproduit ou utilisé sans le consentement de EXM

No.	Revisions	Date	By/Par

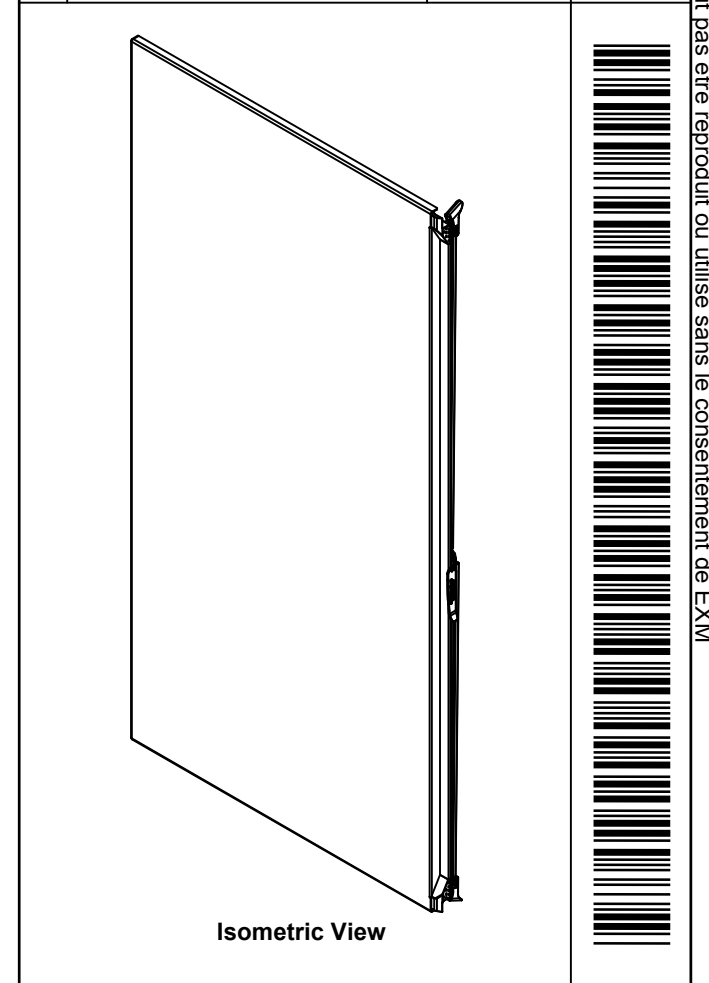

1	STK-P-02400S	0	Powder Paint (Asa-61 Grey / Smooth)
1	STK-G-03400	0	5500 DD Lower Flange Door Gasket
1	STK-G-03300	0	5500 DD Upper Flange Door Gasket
2	STK-Q-90045	0	Cabinet - Closing Bar End
2	STK-Q-45670-72	2	5500 DDS - Flange Door Closing Bar
1	STK-K-50556	4	9500 DD - Flange Door Handle Assy
1	STK-K-20730	4	5500 DDS - Flange Door Stiffener Assembly
1	STK-Q-16122	1	Stud M10 x 20mm
1	STK-G-00701	0	1" x 1/4" Self-Adhesive Neoprene Gasket
1	5500DDS727212FDG	0	5500DDS 72" x 72" Flange Door Gasket
2	STK-Q-16405	6	Guide Stud - Small (No Paint Cap Required)
10	STK-Q-16055	1	M6 x 18mm Stud (No Paint Cap Required)
1	5500DDS727212FD-P	0	5500DDS 72" x 72" Flange Door Part
4	STK-K-09860	7	Cabinet Hinge with Captive Pins
Qty	Part Name	Rev	Description
Parts List			

<p>Tél: (450) 979-4373 Fax: (450) 979-4626 www.exmweb.com</p>	Flatness Aplatissement	Max 3.0mm
	Projection	
Customer Client	Date	
Drawn By Dessiné Par	BoxCad: BoxCad	Date 10-Sep-14
Material Matière	12 Ga Cold Rolled A1008 CS Type B (2.5mm)	
Color Couleur	Asa-61 Grey	Finish Fini Smooth
Description	Detail Rev.	
5500DDS 72" x 72" Flange Door		
Part Number Numéro Pièce	Rev. 0	3
5500DDS727212FD		3

This drawing is confidential and must not be reproduced or used without the consent of EXM

Ce dessin est confidentiel et ne doit pas être reproduit ou utilisé sans le consentement de EXM



TOP

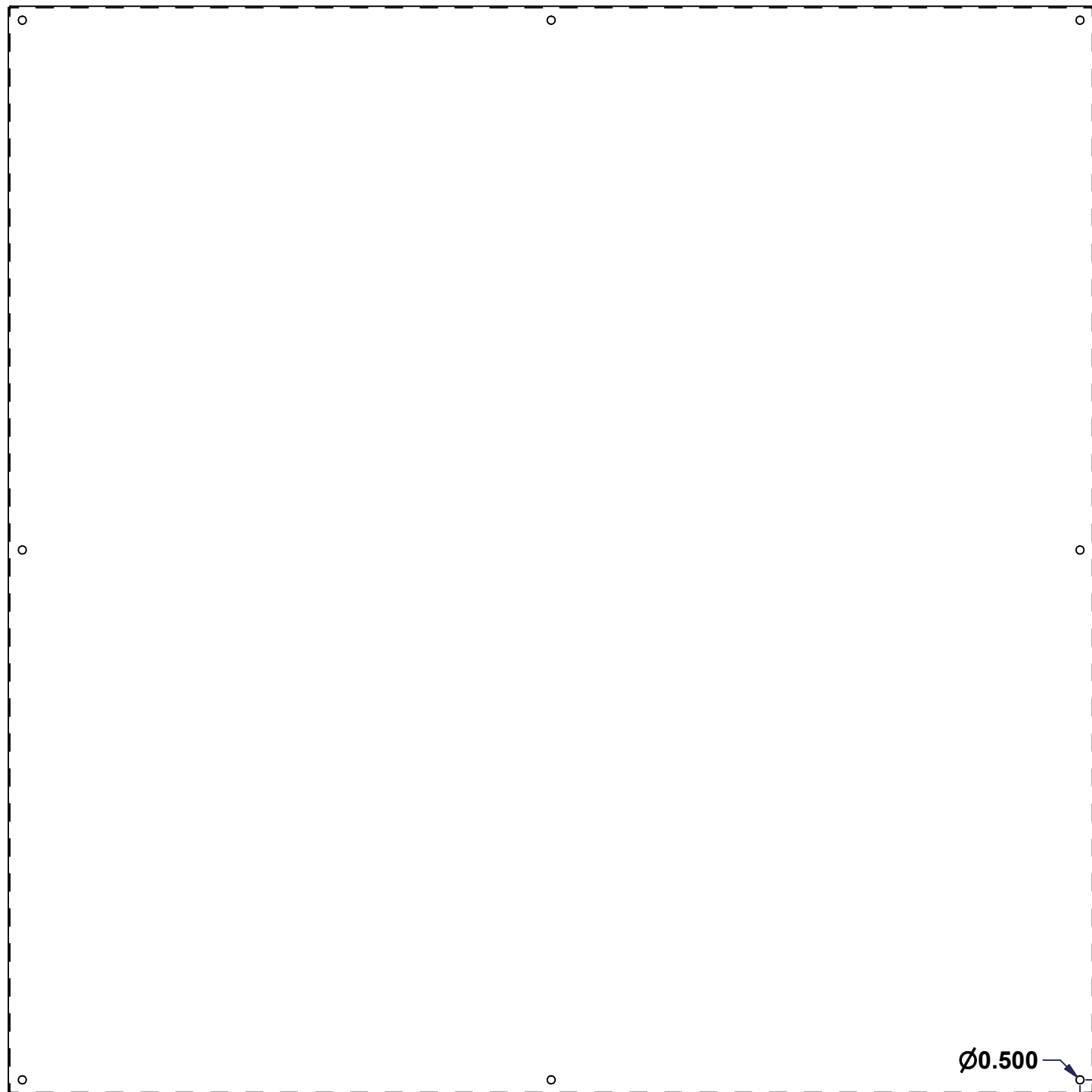

FRONT



RIGHT

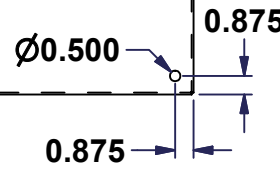

0.000

SEE BILL OF MATERIAL ON LAST PAGE

No.	Revisions	Date	By/Par

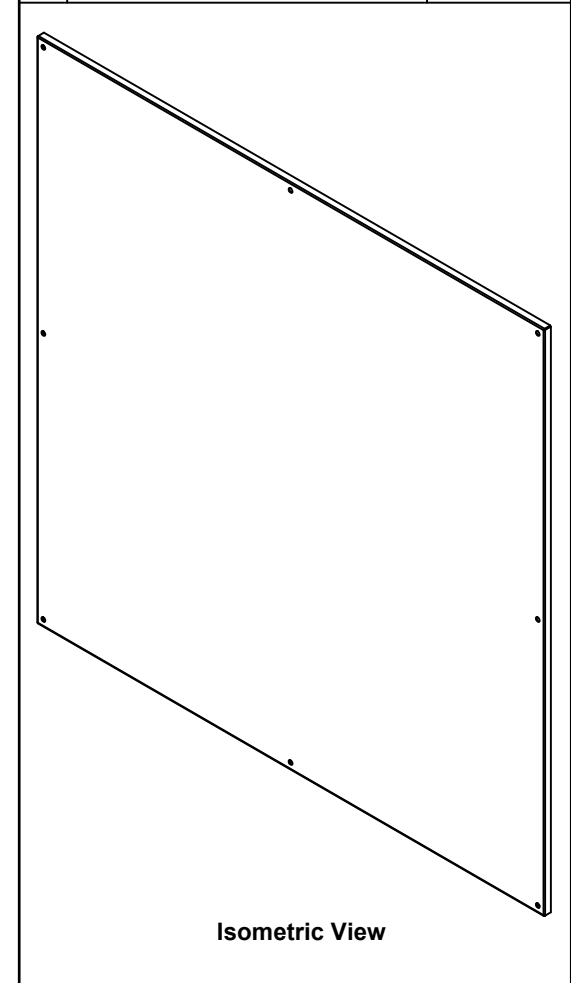

Isometric View



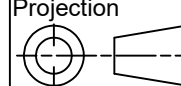

 Tél: (450) 979-4373 Fax: (450) 979-4626 www.exmweb.com		Flatness Aplatissement Max 3.0mm Projection 
Customer Client	Date	
Drawn By Dessiné Par	BoxCad	Date 04/11/2009
Material Matière	12 Ga Galvanized (2.5mm)	
Color Couleur	Unpainted	Finish Fini Unpainted
Description	Detail Rev.	
885 SP7272G Inner Panel		
Part Number Numéro Pièce	Rev.	1
885SP7272G	0	2

This drawing is confidential and must not be reproduced or used without the consent of EXM

Ce dessin est confidentiel et ne doit pas être reproduit ou utilisé sans le consentement de EXM

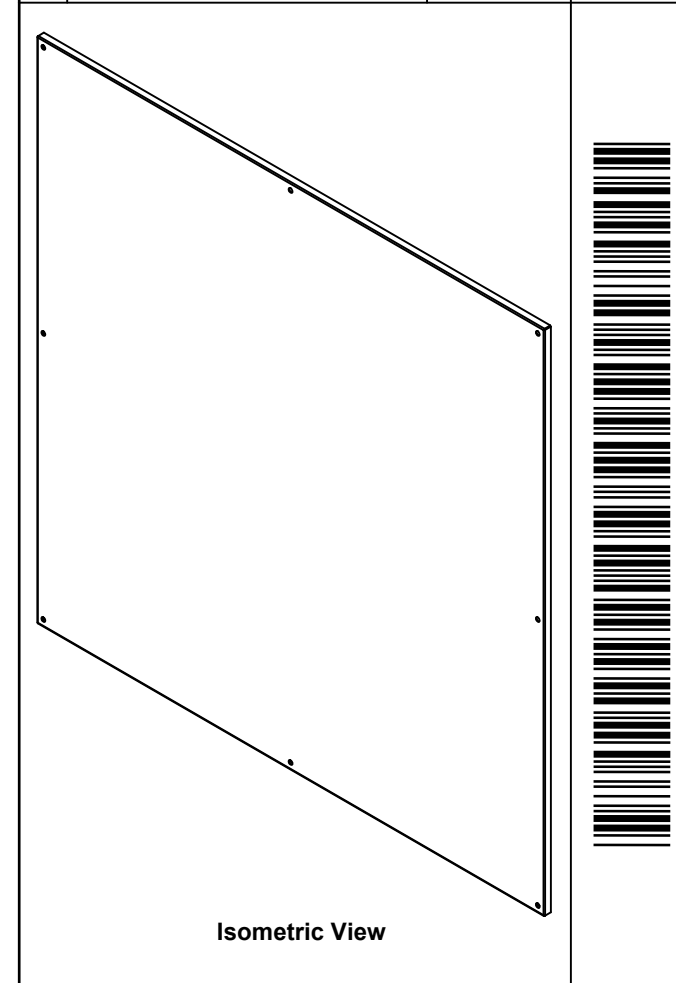
No.	Revisions	Date	By/Par

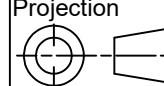

 Tél: (450) 979-4373 Fax: (450) 979-4626 www.exmweb.com		Flatness Aplatissement Max 3.0mm Projection 
Customer Client	Date	
Drawn By Dessiné Par	BoxCad	Date 04/11/2009
Material Matière	12 Ga Galvanized (2.5mm)	
Color Couleur	Unpainted	Finish Fini Unpainted
Description	Detail Rev.	
885 SP7272G Inner Panel		
Part Number Numéro Pièce	Rev. 0	2
885SP7272G	2	

Qty	Part Number	Rev	Description
1	885SP7272G-P	0	885 SP7272G Inner Panel Part
Parts List			