

This drawing is confidential and must not be reproduced or used without the consent of EXM

Ce dessin est confidentiel et ne doit pas être reproduit ou utilisé sans le consentement de EXM

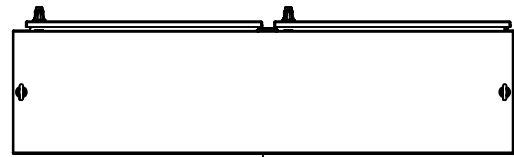

TOP

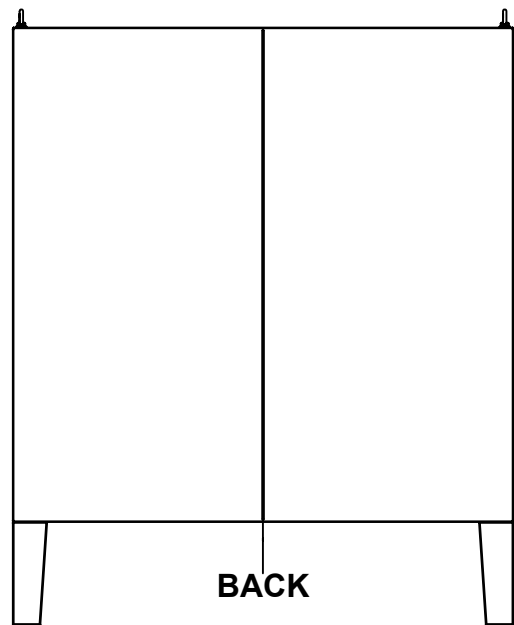

BACK

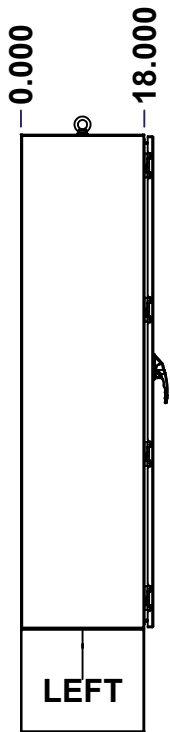

LEFT

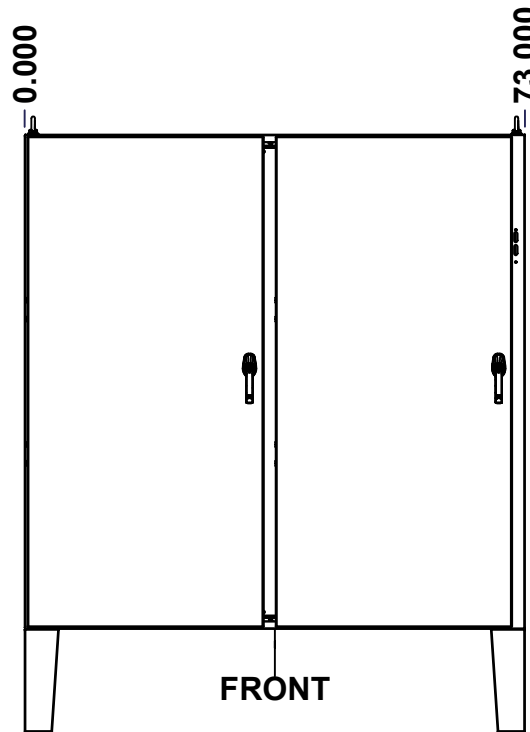

FRONT

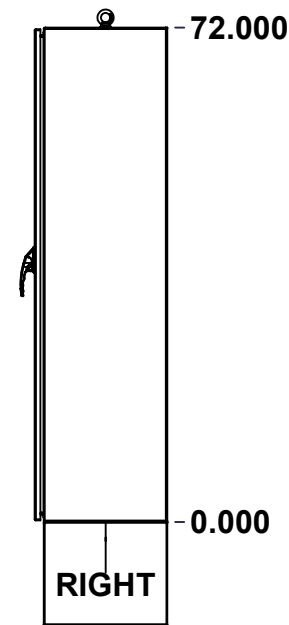

RIGHT

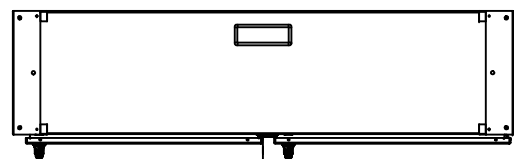

BOTTOM

No.	Revisions	Date	By/Par

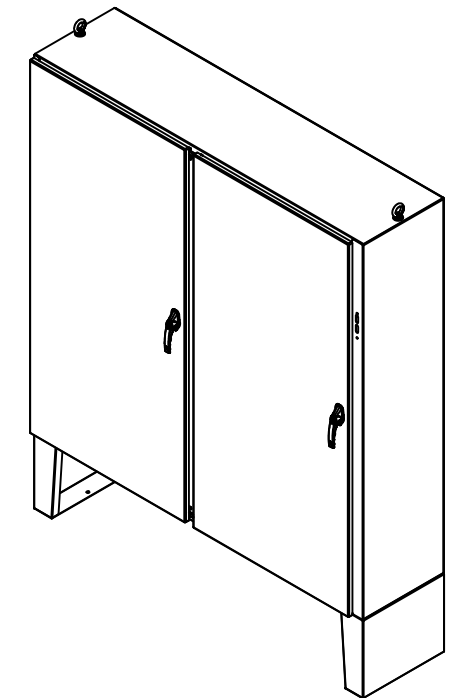

Isometric View

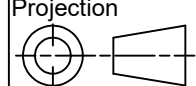

 Tél: (450) 979-4373 Fax: (450) 979-4626 www.exmweb.com		Flatness Aplatissement Max 3.0mm Projection 
Customer Client	Date	
Drawn By Dessiné Par	BoxCad: BoxCad	Date 3/18/2016
Material Matière	12 Ga Cold Rolled A1008 CS Type B (2.5mm)	
Color Couleur	Asa-61 Grey	Finish Fini Smooth
Description		Detail Rev.
5500UFD 72" x 73" x 18" Assembly		
Part Number Numéro Pièce	Rev. 1	2
5500UFD727318		0

SEE BILL OF MATERIAL ON LAST PAGE

This drawing is confidential and must not be reproduced or used without the consent of EXM

Ce dessin est confidentiel et ne doit pas être reproduit ou utilisé sans le consentement de EXM

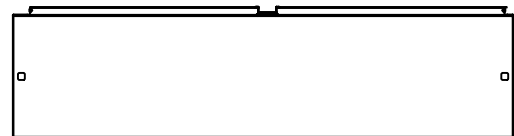

TOP

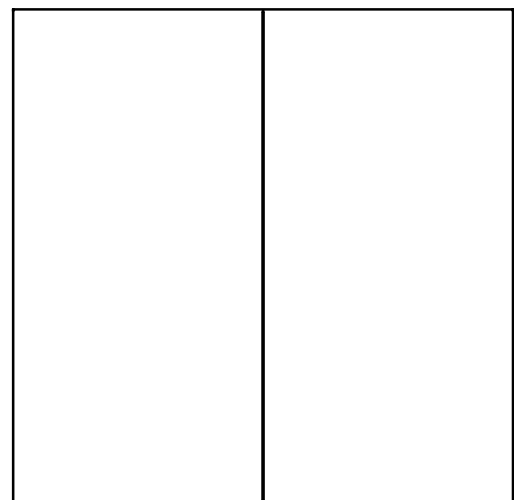

BACK

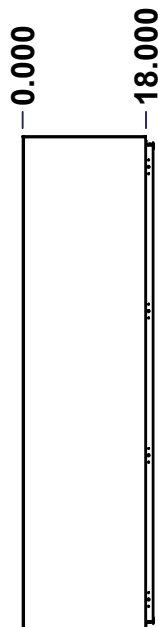

LEFT

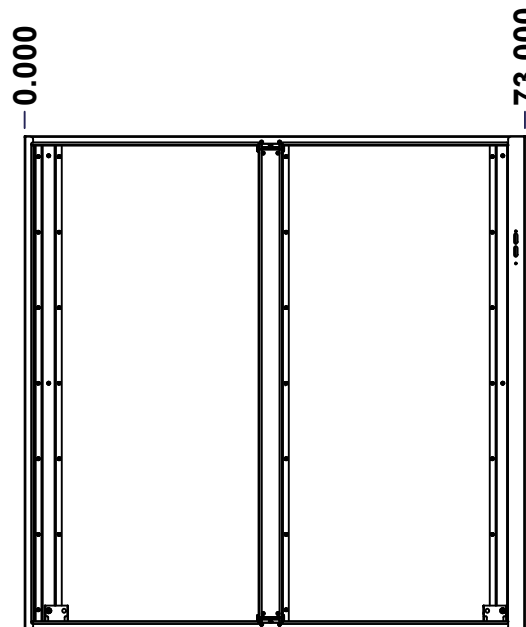

FRONT

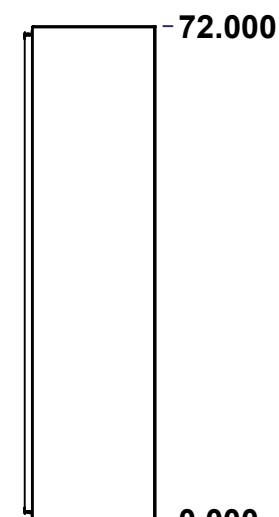

RIGHT

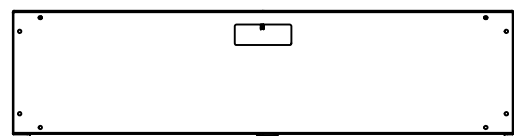

BOTTOM

No.	Revisions	Date	By/Par

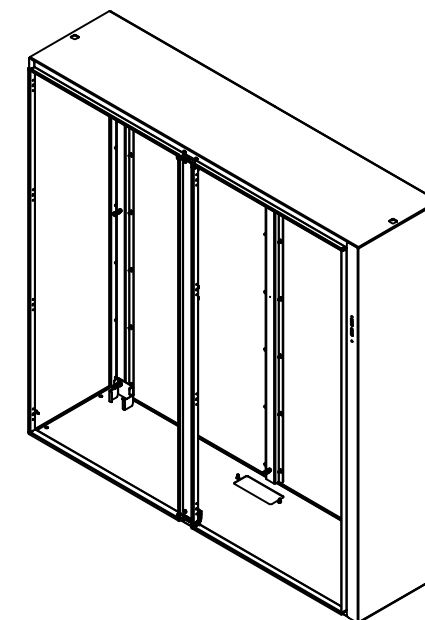

Isometric View



Tél: (450) 979-4373
 Fax: (450) 979-4626
www.exmweb.com

Flatness
Aplatissement

Max 3.0mm

Projection

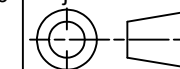

Customer Client	Date
Drawn By Dessiné Par BoxCad: BoxCad	Date 3/18/2016
Material Matière 12 Ga Cold Rolled A1008 CS Type B (2.5mm)	
Color Couleur Asa-61 Grey	Finish Fini Smooth
Description 5500UFD 72" x 73" x 18" Body	Detail Rev.
Part Number Numéro Pièce 5500UFD727318B	Rev. 1 0 2

SEE BILL OF MATERIAL ON LAST PAGE

This drawing is confidential and must not be reproduced or used without the consent of EXM

Ce dessin est confidentiel et ne doit pas être reproduit ou utilisé sans le consentement de EXM

STANDARD FEATURES ARE NOT LISTED IN THIS HOLE TABLE

HOLE TABLE - TOP VIEW (CUSTOM FEATURE ONLY)

CUT-OUT	XDIM	YDIM	DESCRIPTION
1	54.911	13.911	Struts CR400 27.500" (Inside)
2	17.911	13.911	Struts CR400 27.500" (Inside)
3	54.911	13.911	STUDS M6 x 10mm (Inside)
4	44.161	13.911	STUDS M6 x 10mm (Inside)
5	65.661	13.911	STUDS M6 x 10mm (Inside)
6	17.911	13.911	STUDS M6 x 10mm (Inside)
7	7.161	13.911	STUDS M6 x 10mm (Inside)
8	28.661	13.911	STUDS M6 x 10mm (Inside)

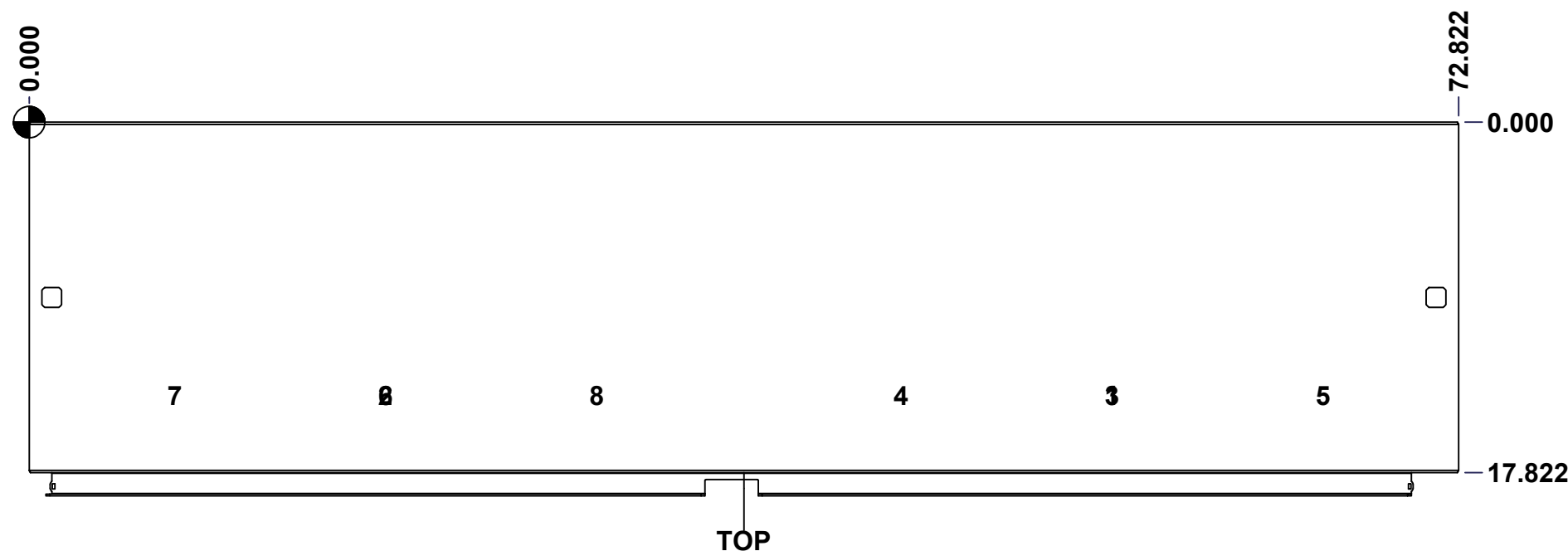

	Description	Status	
	5500UFD 72" x 73" x 18" Body	Released	
	Part Number Numéro Pièce	Rev.	
	5500UFD727318B	0	2 / 7

This drawing is confidential and must not be reproduced or used without the consent of EXM

Ce dessin est confidentiel et ne doit pas être reproduit ou utilisé sans le consentement de EXM

STANDARD FEATURES ARE NOT LISTED IN THIS HOLE TABLE

HOLE TABLE - BOTTOM VIEW (CUSTOM FEATURE ONLY)

CUT-OUT	XDIM	YDIM	DESCRIPTION
1	31.786	3.411	GP STUD M6 x 16mm (Inside)
2	41.036	3.411	GP STUD M6 x 16mm (Inside)

3	3.911	0.911	RND Ø0.500
4	0.911	2.911	RND Ø0.500
5	0.911	14.911	RND Ø0.500
6	3.911	16.911	RND Ø0.500
7	68.911	0.911	RND Ø0.500
8	71.911	2.911	RND Ø0.500
9	71.911	14.911	RND Ø0.500
10	68.911	16.911	RND Ø0.500

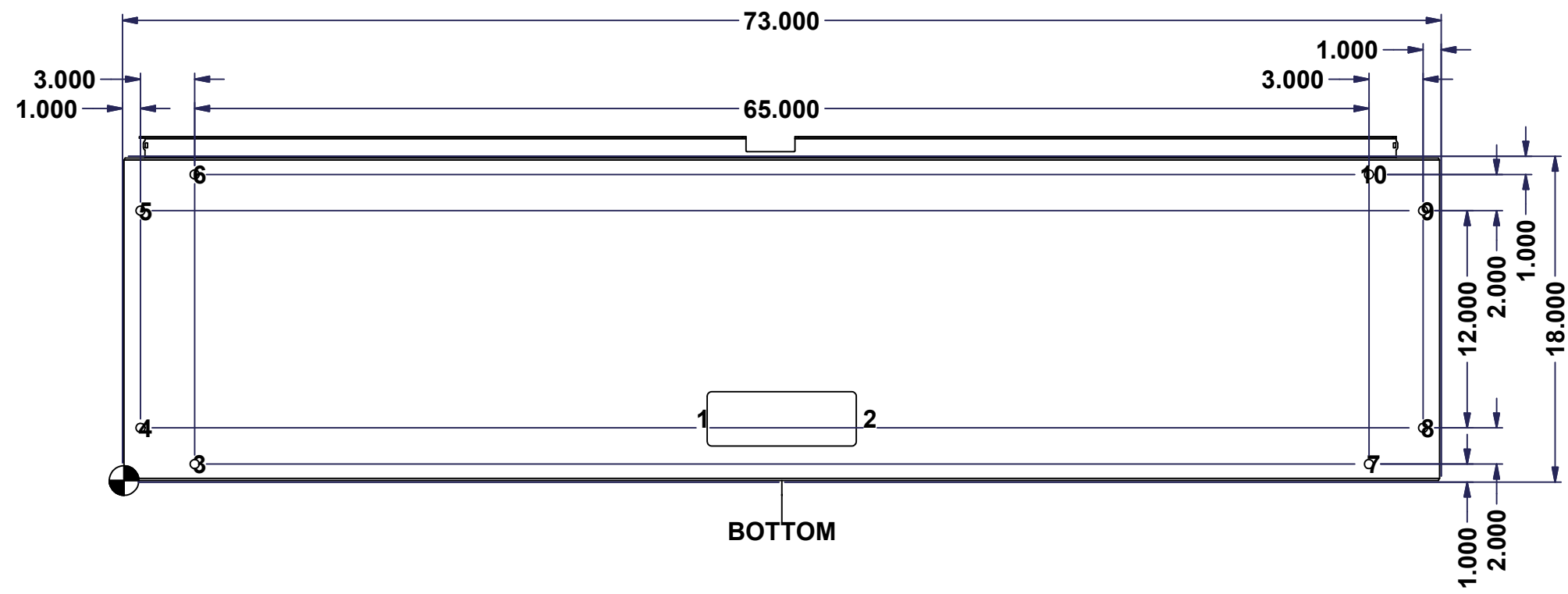

	Description	Status	
	5500UFD 72" x 73" x 18" Body	Released	
	Part Number Numéro Pièce	Rev.	
	5500UFD727318B	0	4 / 7

This drawing is confidential and must not be reproduced or used without the consent of EXM

Ce dessin est confidentiel et ne doit pas être reproduit ou utilisé sans le consentement de EXM

STANDARD FEATURES ARE NOT LISTED IN THIS HOLE TABLE			
HOLE TABLE - LEFT VIEW (CUSTOM FEATURE ONLY)			
CUT-OUT	XDIM	YDIM	DESCRIPTION
1	16.411	3.286	GND STUD M6 x 16mm (Inside)

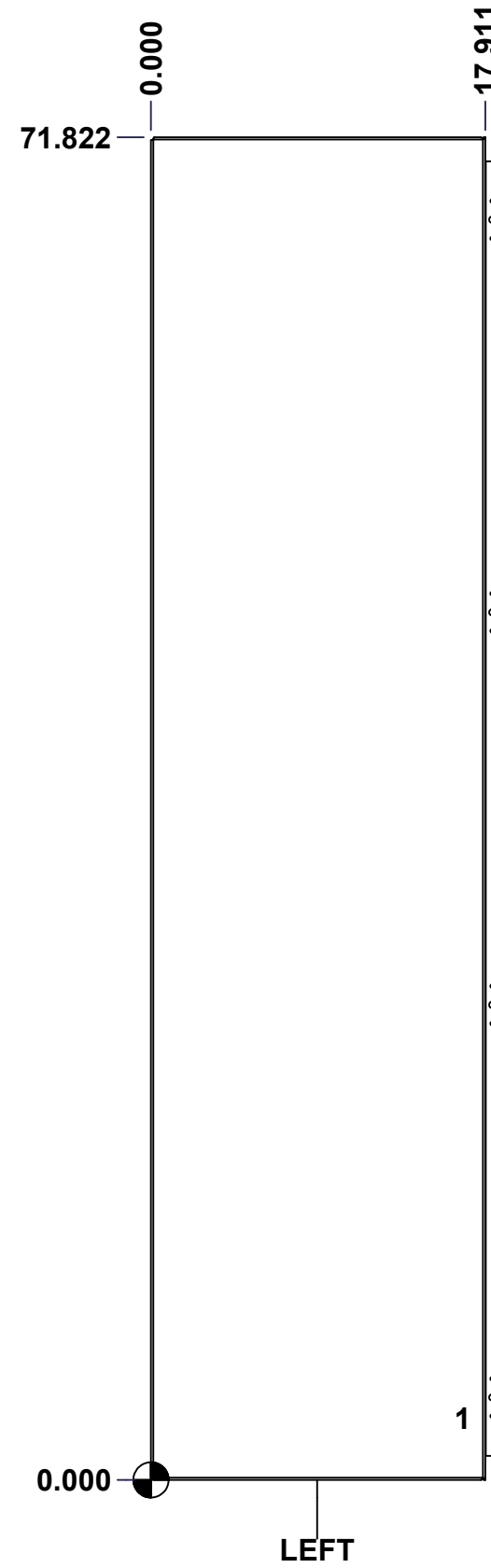

	Description	Status	
	5500UFD 72" x 73" x 18" Body	Released	
	Part Number Numéro Pièce	Rev.	
	5500UFD727318B	0	5 7

This drawing is confidential and must not be reproduced or used without the consent of EXM

Ce dessin est confidentiel et ne doit pas être reproduit ou utilisé sans le consentement de EXM

STANDARD FEATURES ARE NOT LISTED IN THIS HOLE TABLE			
HOLE TABLE - BACK VIEW (CUSTOM FEATURE ONLY)			
CUT-OUT	XDIM	YDIM	DESCRIPTION
1	1.730	3.000	STUDS M6 x 18mm (Inside)
2	1.730	14.000	STUDS M6 x 18mm (Inside)
3	1.730	25.000	STUDS M6 x 18mm (Inside)
4	1.730	36.000	STUDS M6 x 18mm (Inside)
5	1.730	47.000	STUDS M6 x 18mm (Inside)
6	1.730	58.000	STUDS M6 x 18mm (Inside)
7	1.730	69.000	STUDS M6 x 18mm (Inside)
8	4.770	3.000	STUDS M6 x 18mm (Inside)
9	4.770	14.000	STUDS M6 x 18mm (Inside)
10	4.770	25.000	STUDS M6 x 18mm (Inside)
11	4.770	36.000	STUDS M6 x 18mm (Inside)
12	4.770	47.000	STUDS M6 x 18mm (Inside)
13	4.770	58.000	STUDS M6 x 18mm (Inside)
14	4.770	69.000	STUDS M6 x 18mm (Inside)
15	34.855	3.000	STUDS M6 x 18mm (Inside)
16	34.855	14.000	STUDS M6 x 18mm (Inside)
17	34.855	25.000	STUDS M6 x 18mm (Inside)
18	34.855	36.000	STUDS M6 x 18mm (Inside)
19	34.855	47.000	STUDS M6 x 18mm (Inside)
20	34.855	58.000	STUDS M6 x 18mm (Inside)
21	34.855	69.000	STUDS M6 x 18mm (Inside)
22	37.895	3.000	STUDS M6 x 18mm (Inside)
23	37.895	14.000	STUDS M6 x 18mm (Inside)
24	37.895	25.000	STUDS M6 x 18mm (Inside)
25	37.895	36.000	STUDS M6 x 18mm (Inside)
26	37.895	47.000	STUDS M6 x 18mm (Inside)
27	37.895	58.000	STUDS M6 x 18mm (Inside)
28	37.895	69.000	STUDS M6 x 18mm (Inside)
29	67.980	3.000	STUDS M6 x 18mm (Inside)
30	67.980	14.000	STUDS M6 x 18mm (Inside)
31	67.980	25.000	STUDS M6 x 18mm (Inside)
32	67.980	36.000	STUDS M6 x 18mm (Inside)
33	67.980	47.000	STUDS M6 x 18mm (Inside)
34	67.980	58.000	STUDS M6 x 18mm (Inside)
35	67.980	69.000	STUDS M6 x 18mm (Inside)
36	71.020	3.000	STUDS M6 x 18mm (Inside)
37	71.020	14.000	STUDS M6 x 18mm (Inside)
38	71.020	25.000	STUDS M6 x 18mm (Inside)
39	71.020	36.000	STUDS M6 x 18mm (Inside)
40	71.020	47.000	STUDS M6 x 18mm (Inside)
41	71.020	58.000	STUDS M6 x 18mm (Inside)
42	71.020	69.000	STUDS M6 x 18mm (Inside)

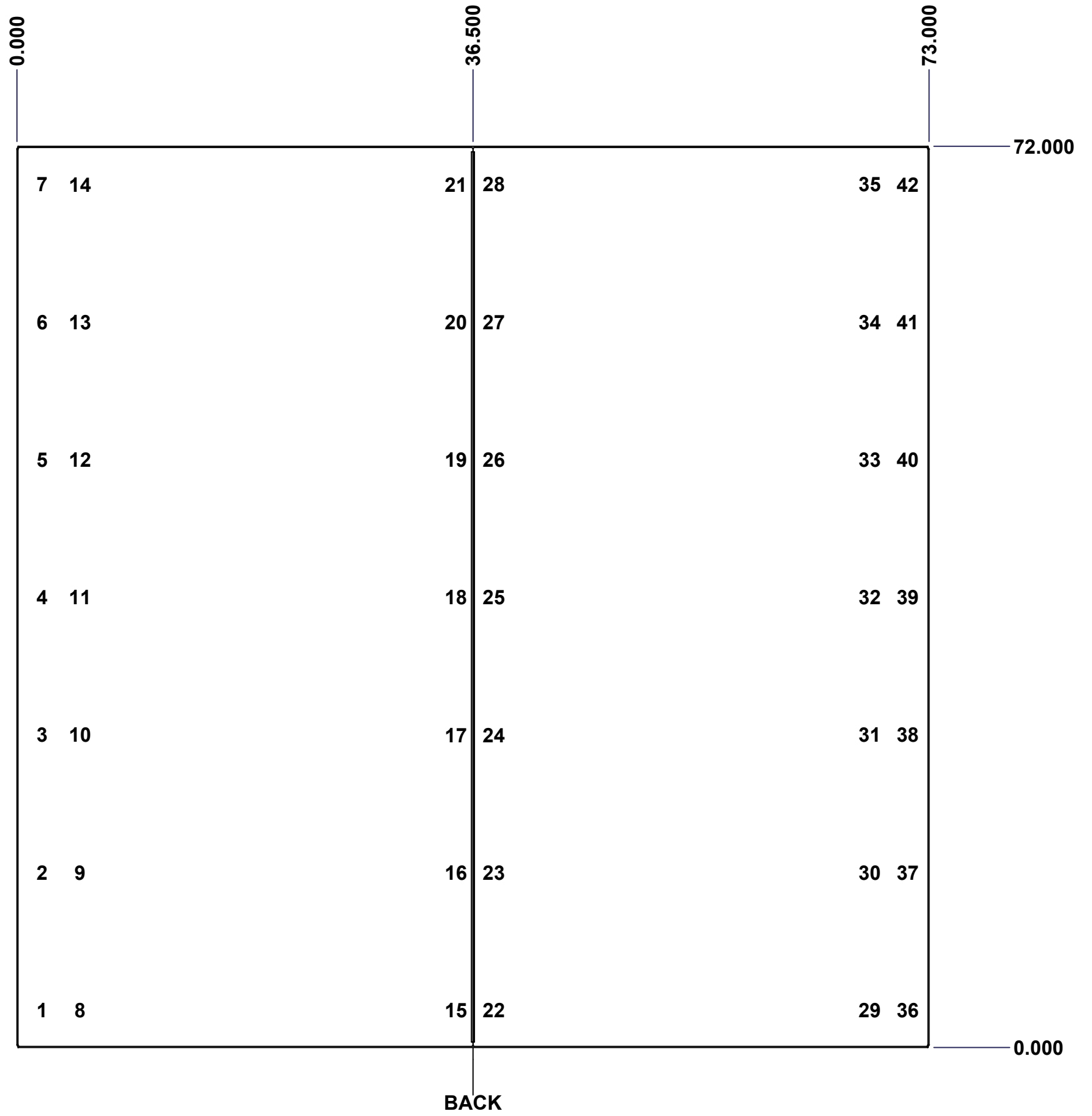

	Description	Status	
	5500UFD 72" x 73" x 18" Body	Released	
	Part Number	Rev.	6
	Numéro Pièce	0	7
	5500UFD727318B		

This drawing is confidential and must not be reproduced or used without the consent of EXM

Ce dessin est confidentiel et ne doit pas être reproduit ou utilisé sans le consentement de EXM

STANDARD FEATURES ARE NOT LISTED IN THIS HOLE TABLE

HOLE TABLE - CENTER VIEW (CUSTOM FEATURE ONLY)

CUT-OUT	XDIM	YDIM	DESCRIPTION
1	1.895	2.262	IP STUD M10 x 40mm (Outside)
2	1.895	35.387	IP STUD M10 x 40mm (Outside)
3	1.895	68.512	IP STUD M10 x 40mm (Outside)

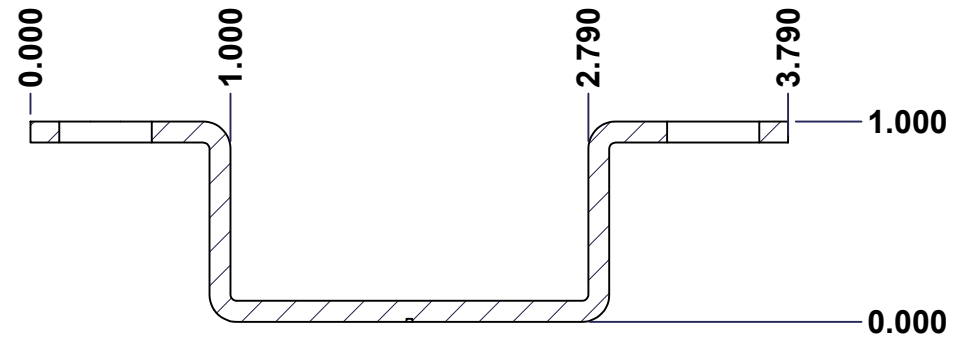
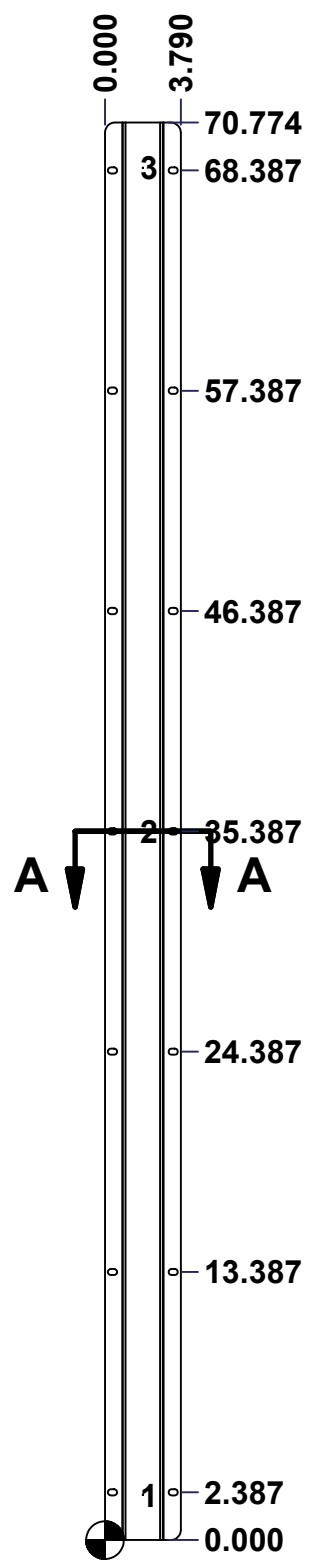

	Description	Status	
	5500UFD 72" x 73" x 18" Body	Released	
	Part Number Numéro Pièce	Rev.	
	5500UFD727318B	0	6 7

This drawing is confidential and must not be reproduced or used without the consent of EXM

Ce dessin est confidentiel et ne doit pas être reproduit ou utilisé sans le consentement de EXM

No.	Revisions	Date	By/Par

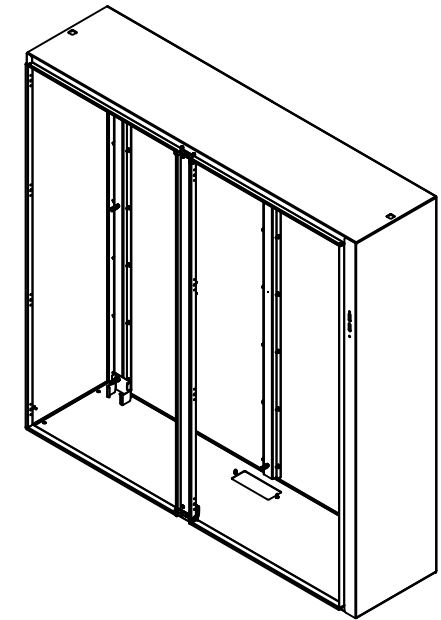

Isometric View

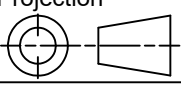

6	STK-Q-16030	0	Stud M6 x 10mm
1	STK-P-02400S	0	Powder Paint (Asa-61 Grey / Smooth)
1	STK-A-75454	3	Center Post - Sealing Block with Latch Assembly (Large)
1	5500UFD727318CP-P	0	5500UFD 72" Center Post Part
8	STK-Q-16100	0	Stud M10 x 40mm
2	STK-Q-07320	0	Flange Lock Nut M10
2	STK-Q-07618	1	5500 Series Inner Panel Support Bracket
3	5500UFD727318POST-P	0	5500UFD 72" IP Post Part
1	5500UFD727318BT-P	0	5500UFD 73" x 18" Bottom Part
1	5500UFD727318T-P	0	5500UFD 73" x 18" Top Part
1	5500UFD727318RS-P	0	5500UFD 72" x 73" Right Part
1	5500UFD727318LS-P	0	5500UFD 72" x 73" Left Part
1	5500UFD727318BR-P	0	5500UFD 72" x 73" Back Right Part
1	5500UFD727318BL-P	0	5500UFD 72" x 73" Back Left Part
2	CR400MS_27.5	0	Commercial Roll Mild Steel (27.5in long)
48	STK-Q-07220	1	M6 Nylon Insert Lock Nut
46	STK-Q-16055	1	M6 x 18mm Stud (No Paint Cap Required)
4	STK-Q-16080	0	Ground Stud M6 x 16mm
Qty	Part Number	Rev	Description
Parts List			

 Tél: (450) 979-4373 Fax: (450) 979-4626 www.exmweb.com	Flatness Aplatissement
	Max 3.0mm
Projection	
Customer Client	Date
Drawn By Dessiné Par	Date 3/18/2016
Material Matière	12 Ga Cold Rolled A1008 CS Type B (2.5mm)
Color Couleur	Asa-61 Grey
Finish Fini	Smooth
Description	Detail Rev.
5500UFD 72" x 73" x 18" Body	
Part Number Numéro Pièce	Rev. 2
5500UFD727318B	0

This drawing is confidential and must not be reproduced or used without the consent of EXM

Ce dessin est confidentiel et ne doit pas être reproduit ou utilisé sans le consentement de EXM

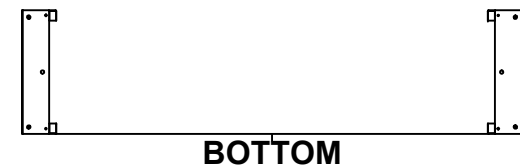
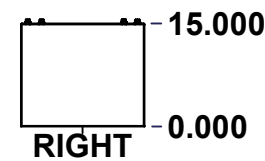
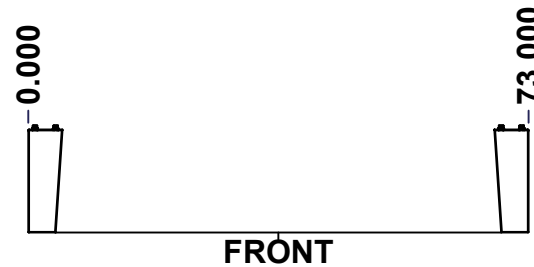
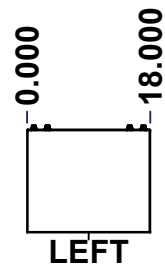
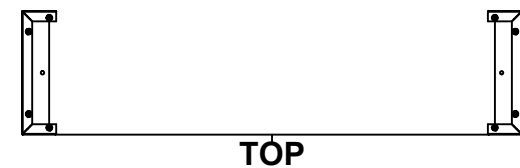

No.	Revisions	Date	By/Par

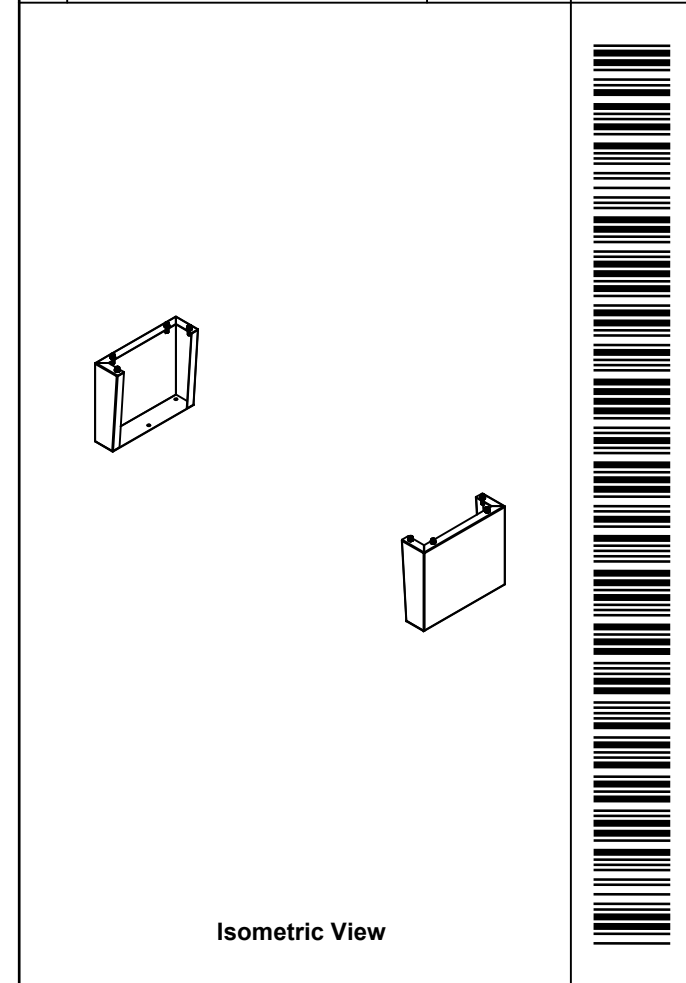

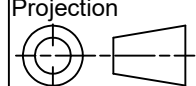
 Tél: (450) 979-4373 Fax: (450) 979-4626 www.exmweb.com		Flatness Aplatissement Max 3.0mm Projection 
Customer Client	Date	
Drawn By Dessiné Par	BoxCad: BoxCad	Date 3/18/2016
Material Matière	12 Ga Cold Rolled A1008 CS Type B (2.5mm)	
Color Couleur	Asa-61 Grey	Finish Fini Smooth
Description		Detail Rev.
885 MFHD 15" x 18" Mounting Feet		
Part Number Numéro Pièce	Rev.	1
5500UFD727318MF	0	4

SEE BILL OF MATERIAL ON LAST PAGE

This drawing is confidential and must not be reproduced or used without the consent of EXM

Ce dessin est confidentiel et ne doit pas être reproduit ou utilisé sans le consentement de EXM

No.	Revisions	Date	By/Par

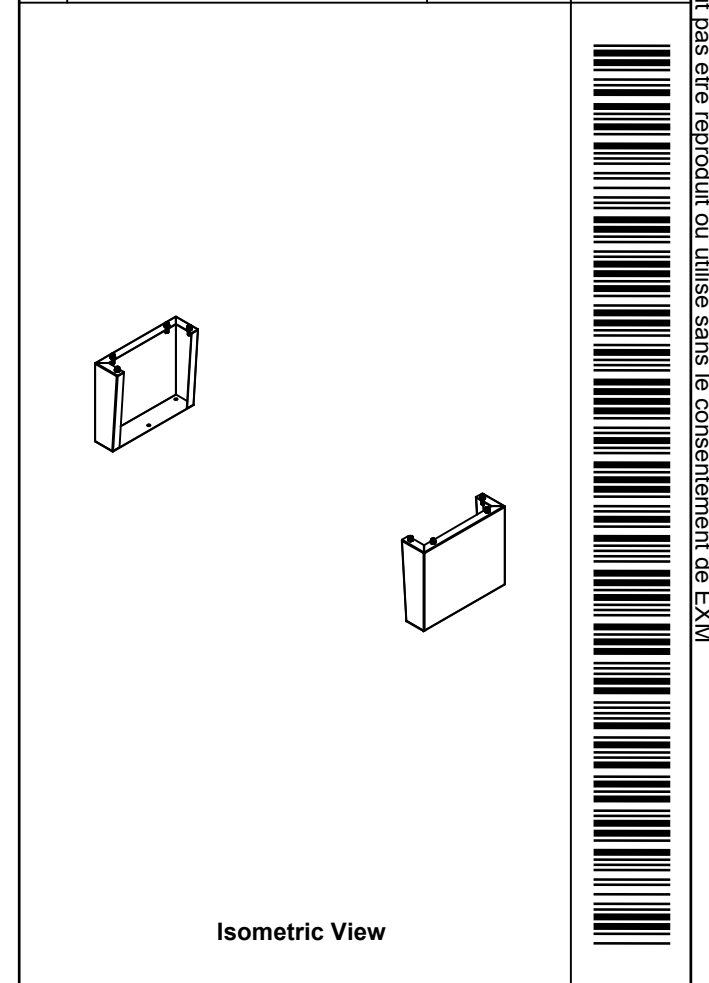

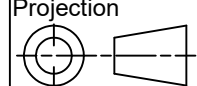
 Tél: (450) 979-4373 Fax: (450) 979-4626 www.exmweb.com		Flatness Aplatissement Max 3.0mm Projection 
Customer Client	Date	
Drawn By Dessiné Par	BoxCad: BoxCad	Date 3/18/2016
Material Matière	12 Ga Cold Rolled A1008 CS Type B (2.5mm)	
Color Couleur	Asa-61 Grey	Finish Fini Smooth
Description		Detail Rev.
885 MFHD 15" x 18" Mounting Feet		
Part Number Numéro Pièce	Rev.	4
5500UFD727318MF	0	4

Qty	Part Name	Rev	Description
1	STK-P-02400S	0	Powder Paint (Asa-61 Grey / Smooth)
8	RIVET_NUT_M10_FH_CE	0	Rivet Nut M10 (Low Profile Close End)
1	5500UFD727318MFR-P	0	885 MFHD 15" x 18" Right Mounting Feet Part
1	5500UFD727318MFL-P	0	885 MFHD 15" x 18" Left Mounting Feet Part
1	STK-K-11600	2	885 MF Accessory Kit
Parts List			

This drawing is confidential and must not be reproduced or used without the consent of EXM

Ce dessin est confidentiel et ne doit pas être reproduit ou utilisé sans le consentement de EXM



TOP

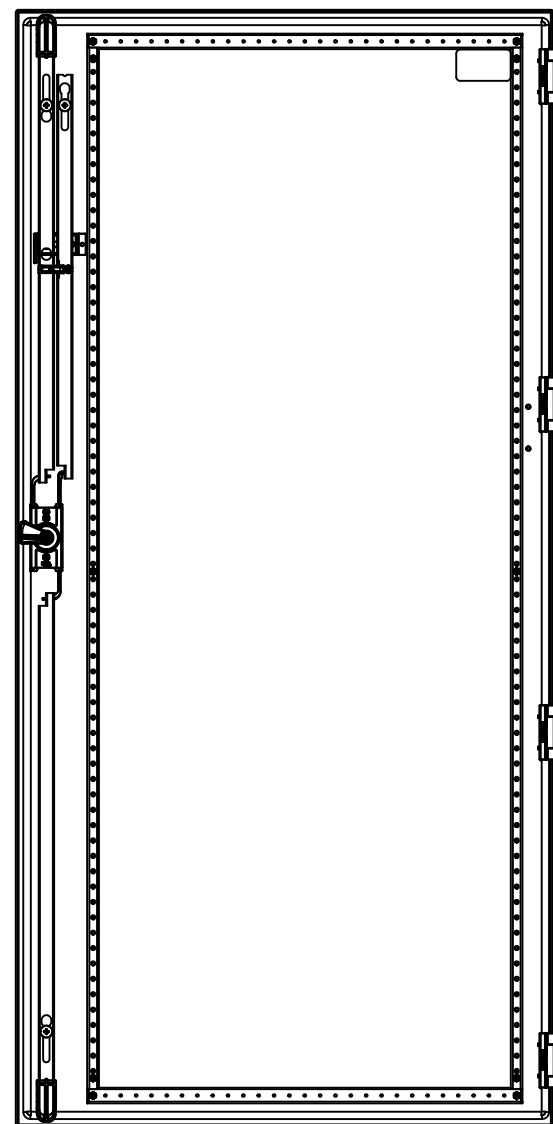

BACK



BOTTOM

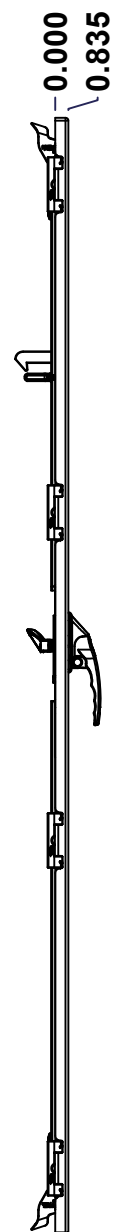

LEFT

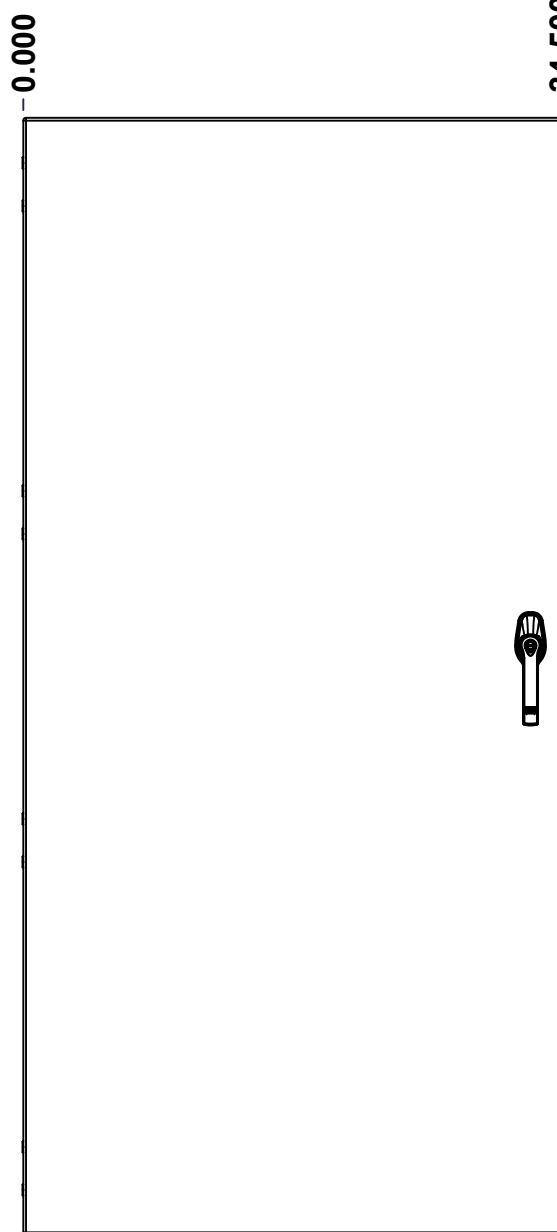

FRONT

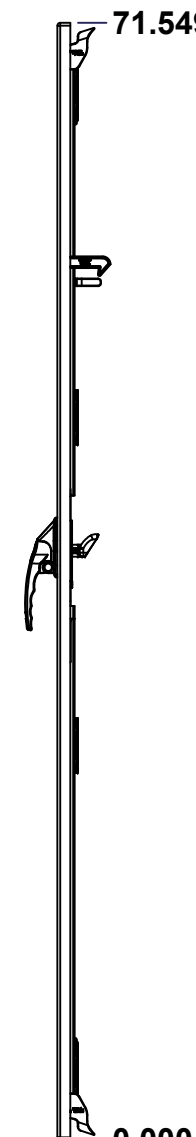

RIGHT

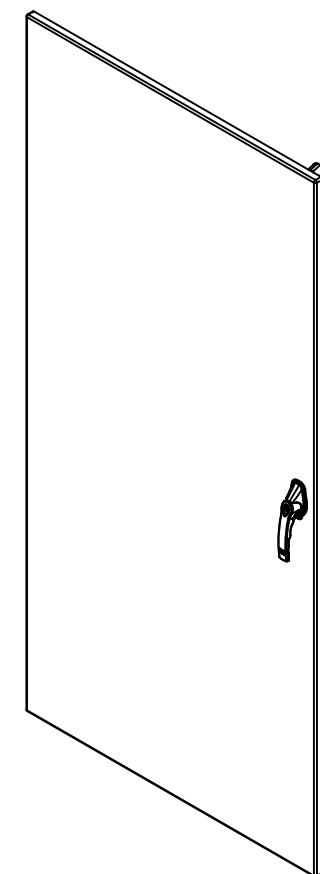

Isometric View



Tél: (450) 979-4373
Fax: (450) 979-4626
www.exmweb.com

Flatness
Aplatissement

Max 3.0mm

Projection

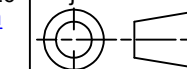

Customer Client	Date
Drawn By / Dessiné Par: BoxCad: BoxCad	Date: 3/18/2016
Material / Matière: 12 Ga Cold Rolled A1008 CS Type B (2.5mm)	
Color / Couleur: Asa-61 Grey	Finish / Fini: Smooth
Description: 5500UFD 72" x 73" Lock Door	Detail Rev.
Part Number / Numéro Pièce: 5500UFD727318LD	Rev. 1 0

SEE BILL OF MATERIAL ON LAST PAGE

This drawing is confidential and must not be reproduced or used without the consent of EXM

Ce dessin est confidentiel et ne doit pas être reproduit ou utilisé sans le consentement de EXM

STANDARD FEATURES ARE NOT LISTED IN THIS HOLE TABLE			
HOLE TABLE - FRONT VIEW (CUSTOM FEATURE ONLY)			
CUT-OUT	XDIM	YDIM	DESCRIPTION
1	2.375	2.028	STUD M6 x 18mm (Inside)
2	2.375	35.580	STUD M6 x 18mm (Inside)
3	2.375	69.521	STUD M6 x 18mm (Inside)
4	2.375	3.139	STUD M6 x 18mm (Inside)
5	2.375	68.409	STUD M6 x 18mm (Inside)
6	29.544	2.028	STUD M6 x 18mm (Inside)
7	29.544	35.580	STUD M6 x 18mm (Inside)
8	29.544	69.521	STUD M6 x 18mm (Inside)
9	29.544	3.139	STUD M6 x 18mm (Inside)
10	29.544	68.409	STUD M6 x 18mm (Inside)
11	32.544	6.118	STUD M6 x 18mm (Inside)
12	32.544	65.430	STUD M6 x 18mm (Inside)
13	31.357	65.430	STUD M6 x 18mm (Inside)
14	32.544	56.525	STUD M6 x 18mm (Inside)
15	31.357	56.525	STUD M6 x 18mm (Inside)

16	32.544	37.743	HANDLE 885 ESL2A-APHD @ 0.0°
17	1.625	43.445	STUDS M6 x 18mm (Inside)
18	1.625	46.123	STUDS M6 x 18mm (Inside)

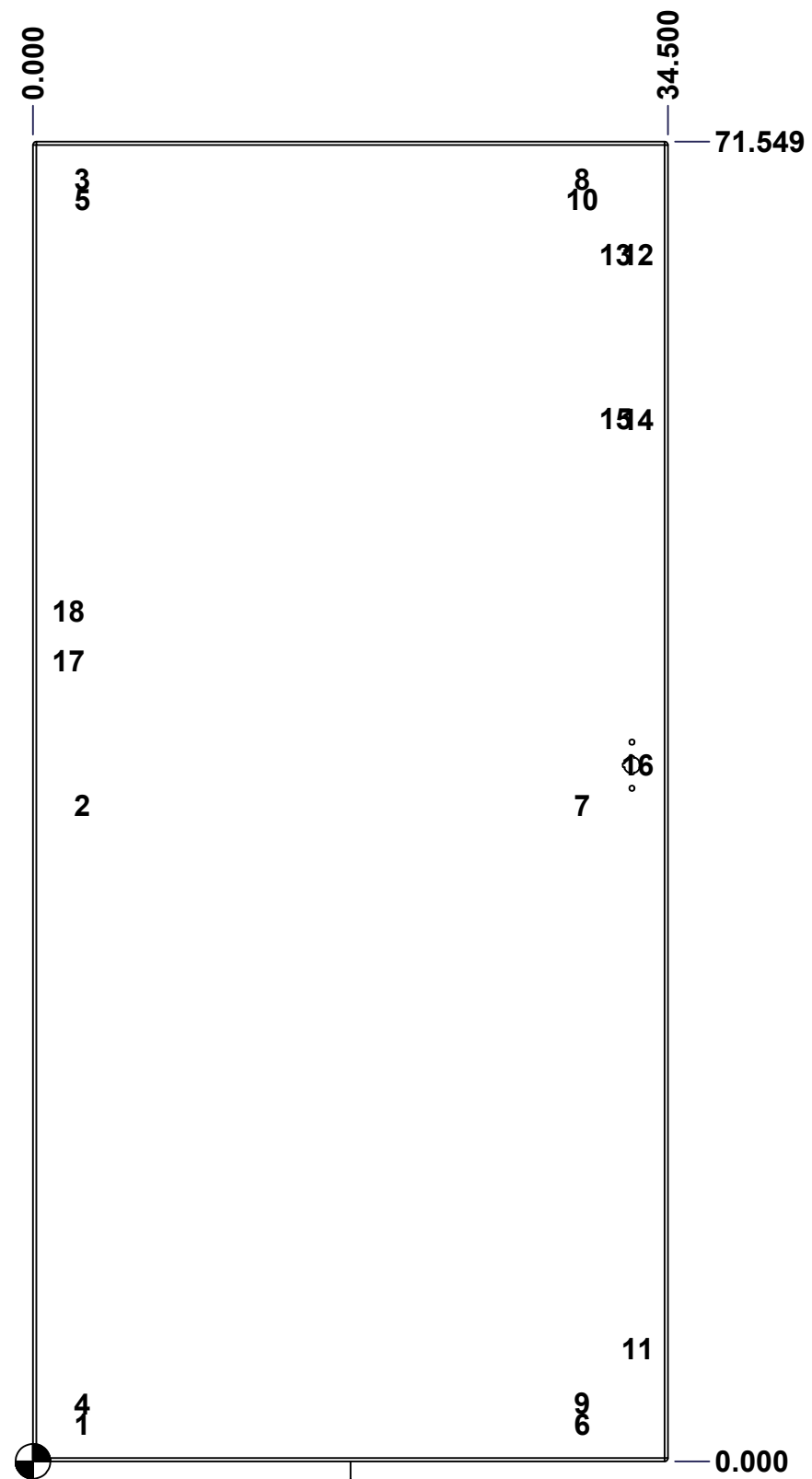

FRONT

	Description	Status
	5500UFD 72" x 73" Lock Door	(NULL)
	Part Number Numéro Pièce	Rev.
	5500UFD727318LD	0
		2
		3

This drawing is confidential and must not be reproduced or used without the consent of EXM

Ce dessin est confidentiel et ne doit pas être reproduit ou utilisé sans le consentement de EXM

No.	Revisions	Date	By/Par

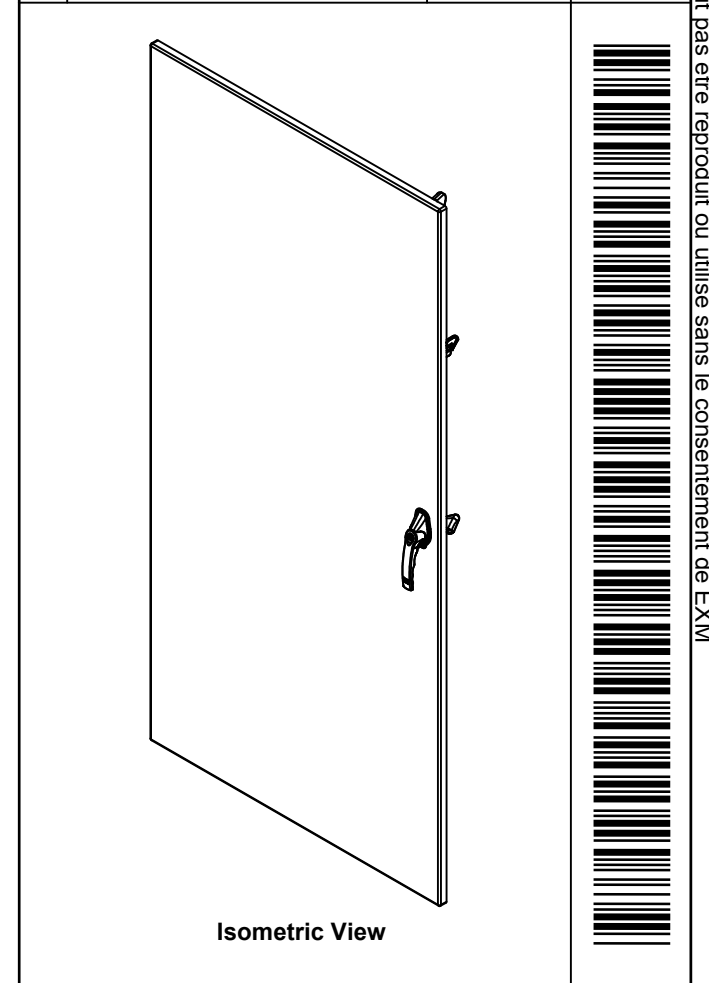

1	5500UFD727318DB_ESY	0	5500UFD 72" Disconnect Defeater Bar
1	5500UFD727318CB	0	5500UFD 72" Closing Bar
1	5500UFD727318CB_ESY	0	5500UFD 72" Disconnect Closing Bar
1	STK-K-03895-36	3	Gearbox Clockwise Assembly (Grip 36mm)
1	885ESL2A-APHD	0	885 ESL2A-APHD - Zinc Die Cast L-Handle Padlockable Assy - Slot Cylinder
1	STK-P-02400S	0	Powder Paint (Asa-61 Grey / Smooth)
1	STK-S-00100	0	3.5" x 2" Silver Milar Flexcon Sticker
1	STK-Q-07220	1	M6 Nylon Insert Lock Nut
1	STK-Q-13060	1	M6 Flat Washer
1	5500UFD727318LDG	0	5500UFD 72" x 73" Lock Door Gasket
1	STK-Q-46600	3	5500 ESY Disconnect Door Hook
1	5500UFD727318DS1	0	5500UFD 72" x 73" Door Stiffener
1	5500UFD727318LD-P	0	5500UFD 72" x 73" Lock Door Part
4	STK-K-09860	7	Cabinet Hinge with Captive Pins
17	STK-Q-16055	1	M6 x 18mm Stud (No Paint Cap Required)
Qty	Part Name	Rev	Description
Parts List			

 Tél: (450) 979-4373 Fax: (450) 979-4626 www.exmweb.com		Flatness Aplatissement	
		Max 3.0mm	
Customer Client		Date	
Drawn By Dessiné Par		Date 3/18/2016	
Material Matière		12 Ga Cold Rolled A1008 CS Type B (2.5mm)	
Color Couleur		Asa-61 Grey	
Finish Fini		Smooth	
Description			Detail Rev.
5500UFD 72" x 73" Lock Door			
Part Number Numéro Pièce		Rev.	3
5500UFD727318LD		0	3

This drawing is confidential and must not be reproduced or used without the consent of EXM

Ce dessin est confidentiel et ne doit pas être reproduit ou utilisé sans le consentement de EXM

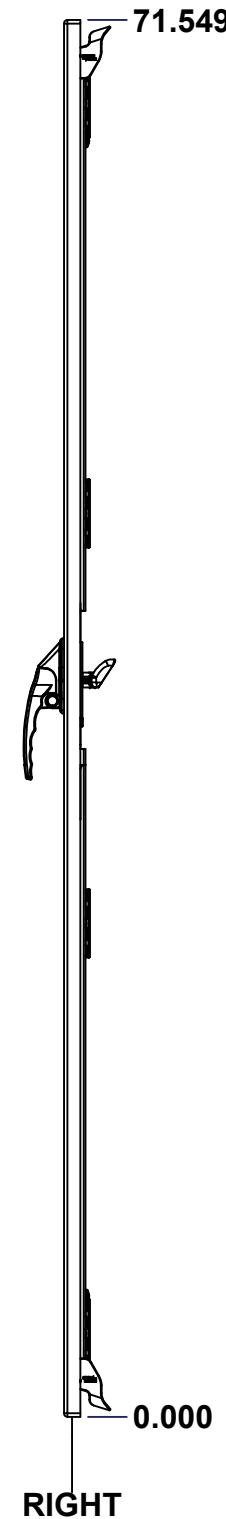
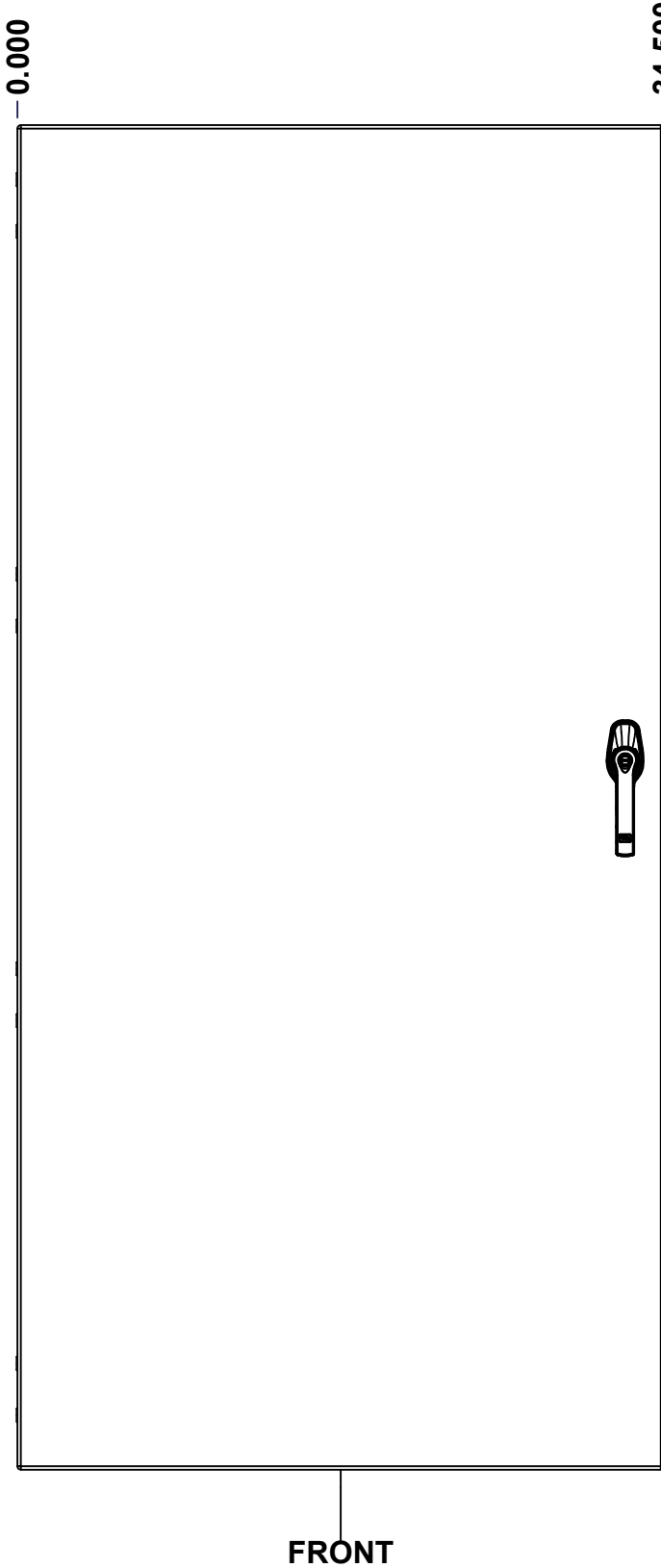
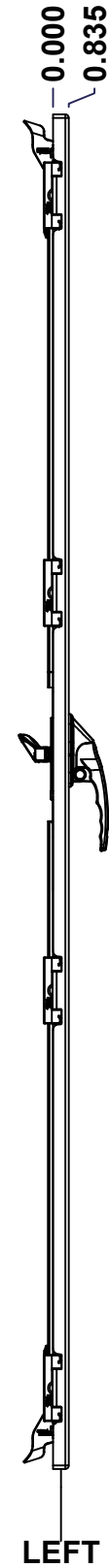
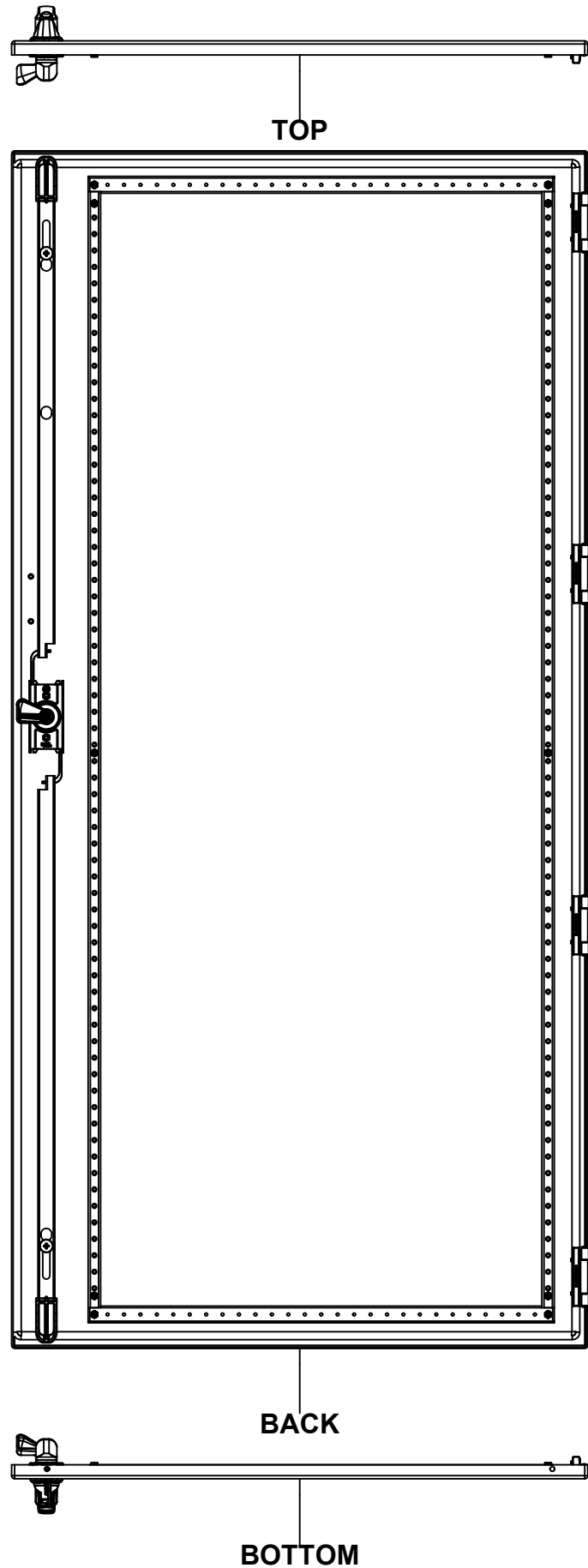

No.	Revisions	Date	By/Par

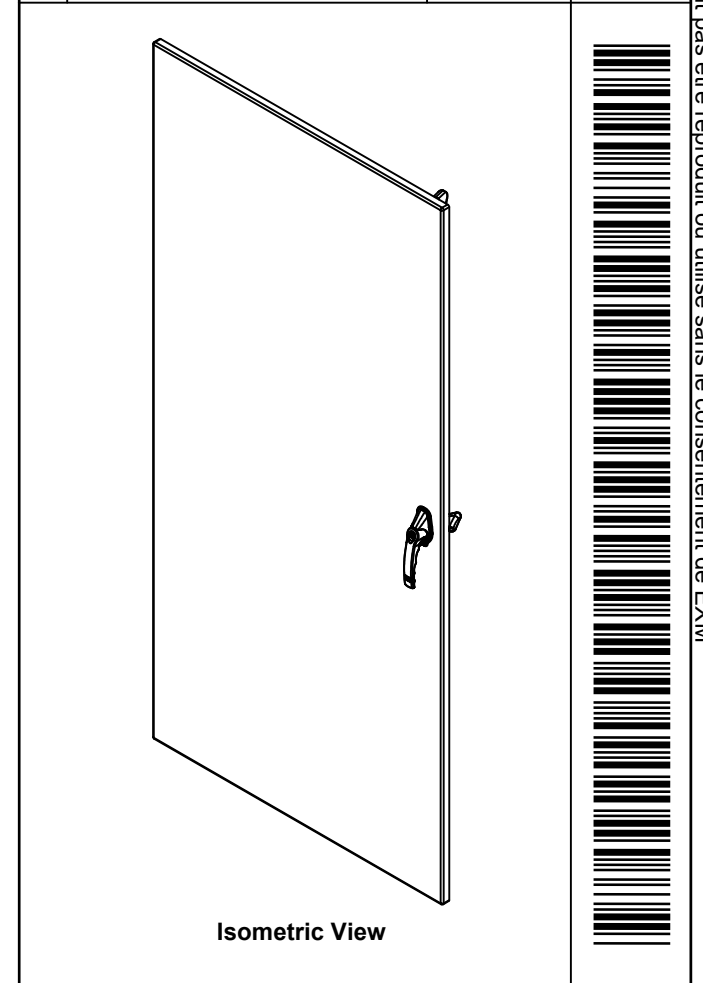

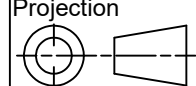
 Tél: (450) 979-4373 Fax: (450) 979-4626 www.exmweb.com		Flatness Aplatissement	
		Max 3.0mm	
Customer Client		Date	
Drawn By Dessiné Par BoxCad: BoxCad		Date 3/18/2016	
Material Matière 12 Ga Cold Rolled A1008 CS Type B (2.5mm)		Projection	
Color Couleur Asa-61 Grey		 Finish Fini Smooth	
Description 5500UFD 72" x 73" Lock Door		Detail Rev.	
Part Number Numéro Pièce 5500UFD727318FD		Rev. 0	1 3

SEE BILL OF MATERIAL ON LAST PAGE

This drawing is confidential and must not be reproduced or used without the consent of EXM

Ce dessin est confidentiel et ne doit pas être reproduit ou utilisé sans le consentement de EXM

STANDARD FEATURES ARE NOT LISTED IN THIS HOLE TABLE

HOLE TABLE - FRONT VIEW (CUSTOM FEATURE ONLY)

CUT-OUT	XDIM	YDIM	DESCRIPTION
1	2.375	2.028	STUD M6 x 18mm (Inside)
2	2.375	35.581	STUD M6 x 18mm (Inside)
3	2.375	69.521	STUD M6 x 18mm (Inside)
4	2.375	3.139	STUD M6 x 18mm (Inside)
5	2.375	68.409	STUD M6 x 18mm (Inside)
6	29.544	2.028	STUD M6 x 18mm (Inside)
7	29.544	35.581	STUD M6 x 18mm (Inside)
8	29.544	69.521	STUD M6 x 18mm (Inside)
9	29.544	3.139	STUD M6 x 18mm (Inside)
10	29.544	68.409	STUD M6 x 18mm (Inside)
11	32.419	6.118	CLOSING BAR GUIDE (Inside)
12	32.419	65.430	CLOSING BAR GUIDE (Inside)
-----	-----	-----	-----
13	32.419	37.743	HANDLE 885 ESL2A-APHD @ 0.0°
14	33.347	43.445	STUDS M6 x 18mm (Inside)
15	33.347	46.123	STUDS M6 x 18mm (Inside)

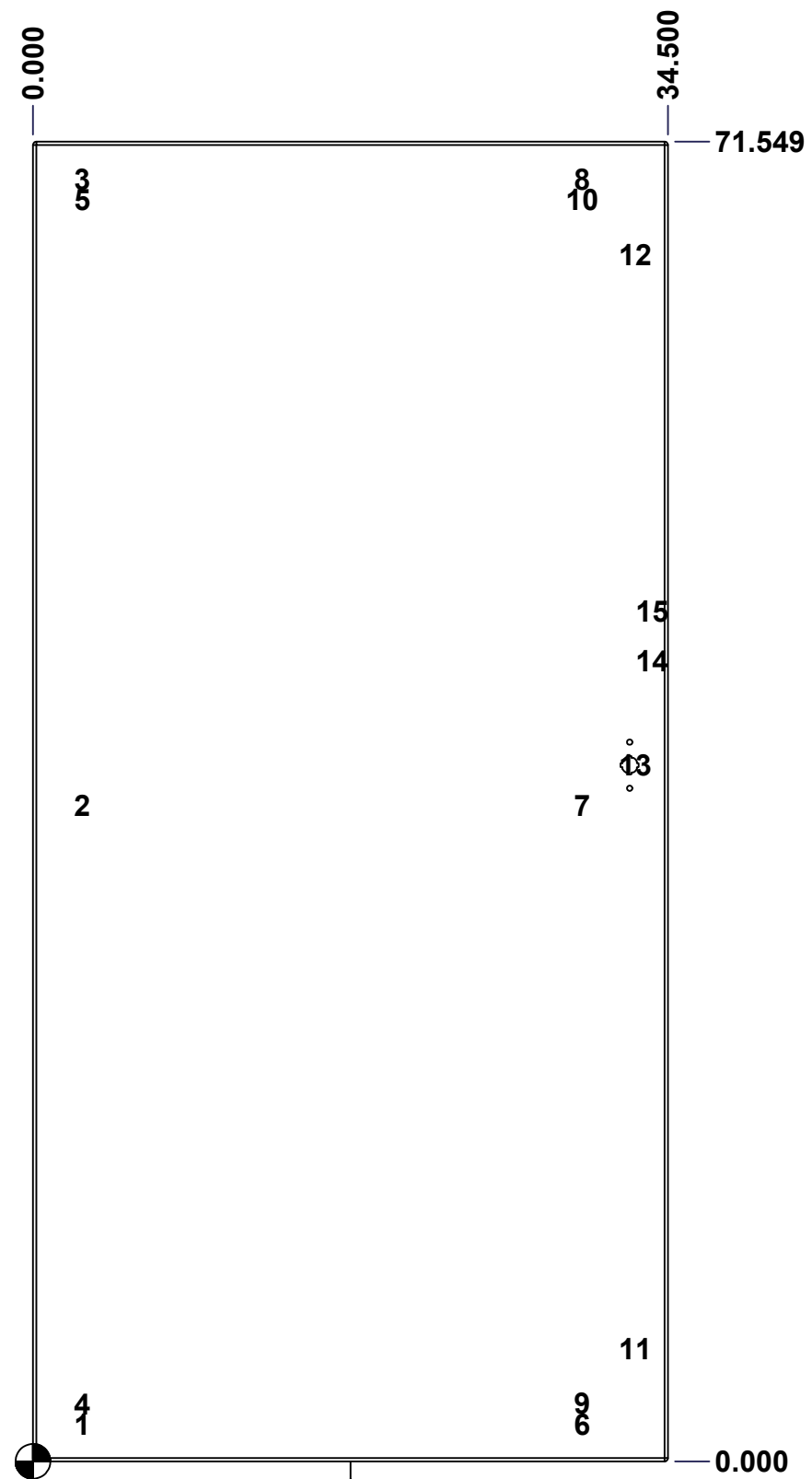

FRONT

	Description	Status
	5500UFD 72" x 73" Lock Door	(NULL)
	Part Number Numéro Pièce	Rev.
	5500UFD727318FD	0
		2
		3

This drawing is confidential and must not be reproduced or used without the consent of EXM

Ce dessin est confidentiel et ne doit pas être reproduit ou utilisé sans le consentement de EXM

No.	Revisions	Date	By/Par

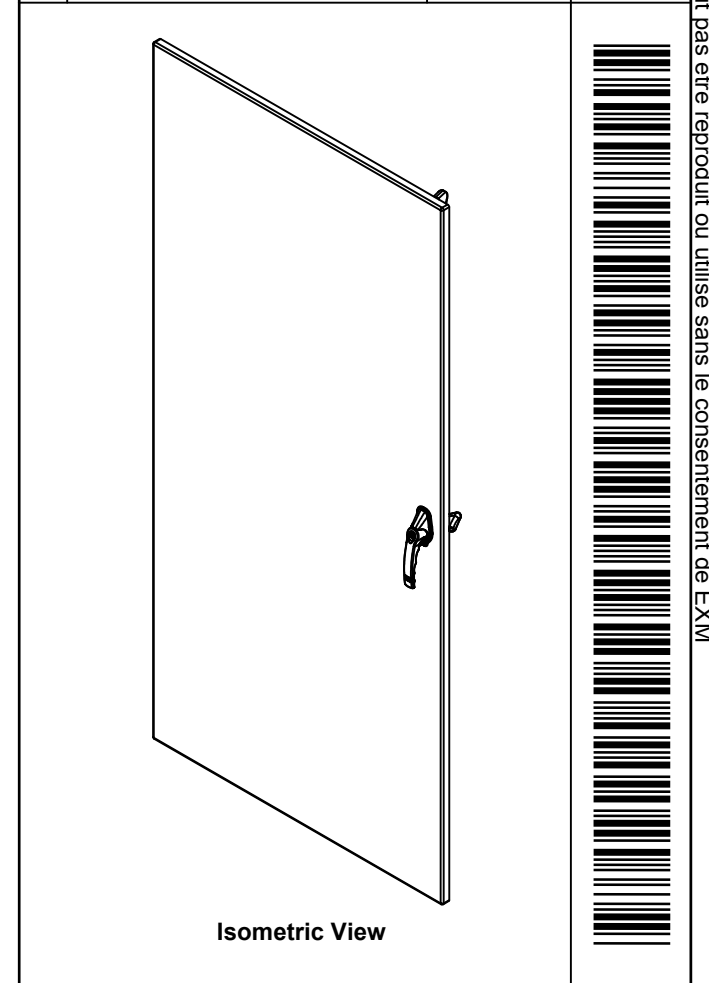

Qty	Part Name	Rev	Description
1	5500UFD727318CB	0	5500UFD 72" Closing Bar
1	5500UFD727318CB2ESY	0	5500UFD 72" Disconnect Closing Bar
1	STK-A-03880-36	12	Gearbox Clockwise Assembly (Grip 36mm)
1	885ESL2A-APHD	0	885 ESL2A-APHD - Zinc Die Cast L-Handle Padlockable Assy - Slot Cylinder
1	5500UFD727318FDG	0	5500UFD 72" x 73" Flange Door Gasket
1	STK-P-02400S	0	Powder Paint (Asa-61 Grey / Smooth)
1	5500UFD727318DS1	0	5500UFD 72" x 73" Door Stiffener
1	5500UFD727318FD-P	0	5500UFD 72" x 73" Lock Door Part
4	STK-K-09860	7	Cabinet Hinge with Captive Pins
14	STK-Q-16055	1	M6 x 18mm Stud (No Paint Cap Required)
Parts List			

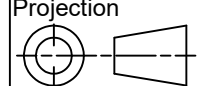
 Tél: (450) 979-4373 Fax: (450) 979-4626 www.exmweb.com		Flatness Aplatissement Max 3.0mm Projection 
Customer Client	Date	Date
Drawn By Dessiné Par	BoxCad: BoxCad	Date 3/18/2016
Material Matière	12 Ga Cold Rolled A1008 CS Type B (2.5mm)	
Color Couleur	Asa-61 Grey	Finish Fini Smooth
Description	5500UFD 72" x 73" Lock Door	
Part Number Numéro Pièce	Rev. 0	3
5500UFD727318FD		3

This drawing is confidential and must not be reproduced or used without the consent of EXM

Ce dessin est confidentiel et ne doit pas être reproduit ou utilisé sans le consentement de EXM



TOP

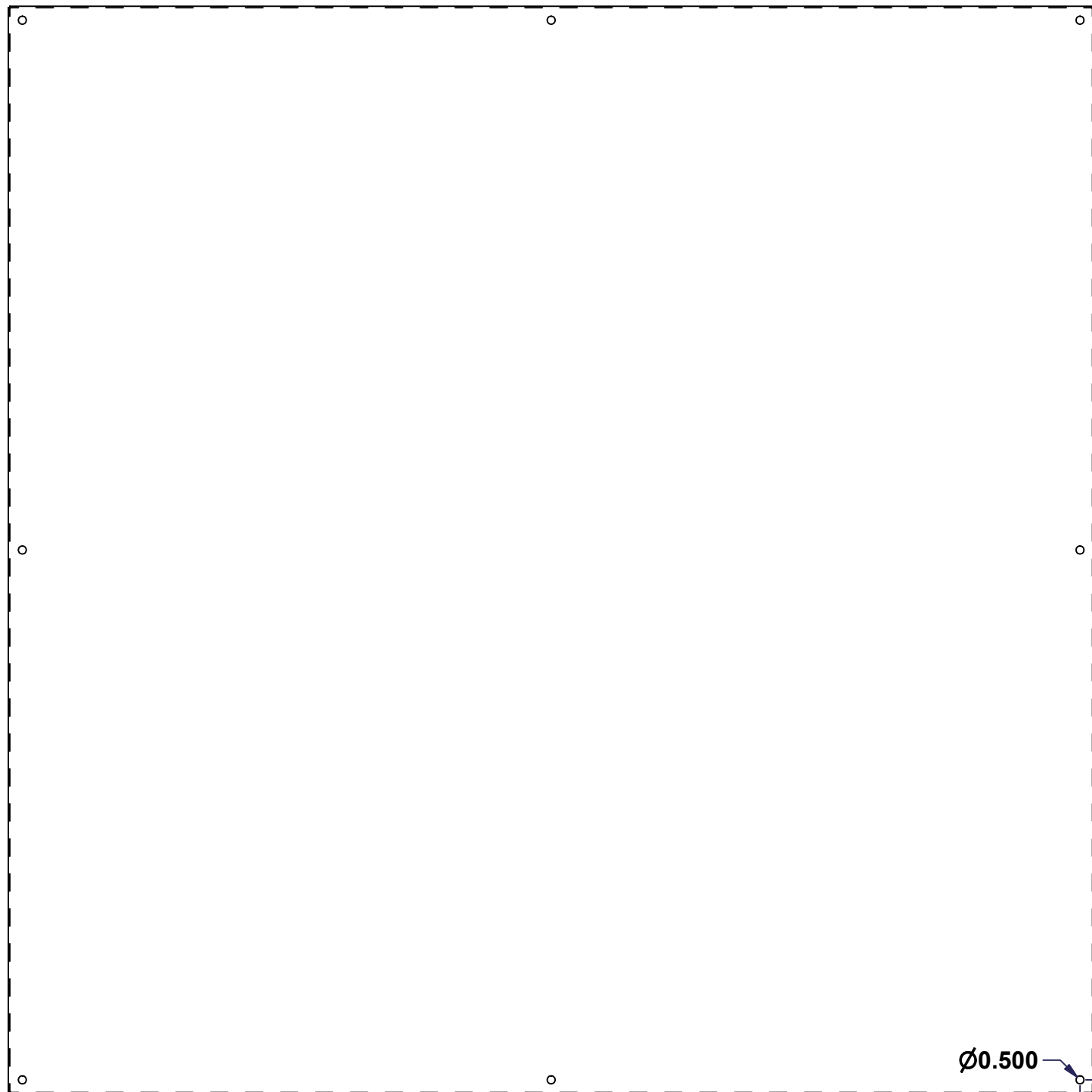

FRONT

0.875

68.000



RIGHT

Ø0.500
0.875
0.875

0.000

No.	Revisions	Date	By/Par

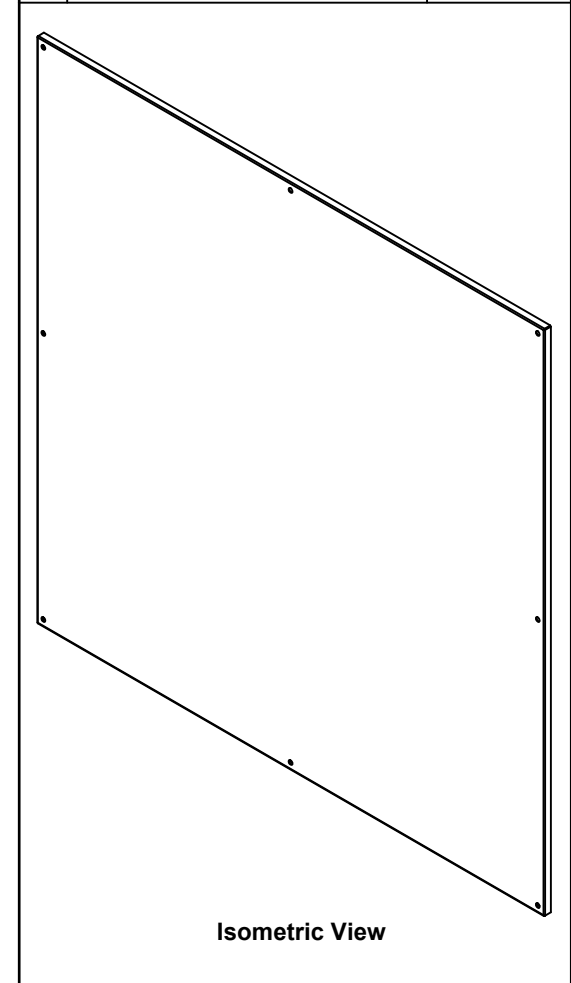

Isometric View

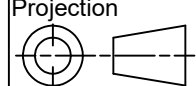

 Tél: (450) 979-4373 Fax: (450) 979-4626 www.exmweb.com		Flatness Aplatissement Max 3.0mm Projection 
Customer Client	Date	
Drawn By Dessiné Par	BoxCad	Date 04/11/2009
Material Matière	12 Ga Galvanized (2.5mm)	
Color Couleur	Unpainted	Finish Fini Unpainted
Description	Detail Rev.	
885 SP7272G Inner Panel		
Part Number Numéro Pièce	Rev.	1
885SP7272G	0	2

SEE BILL OF MATERIAL ON LAST PAGE

This drawing is confidential and must not be reproduced or used without the consent of EXM

Ce dessin est confidentiel et ne doit pas être reproduit ou utilisé sans le consentement de EXM

No.	Revisions	Date	By/Par

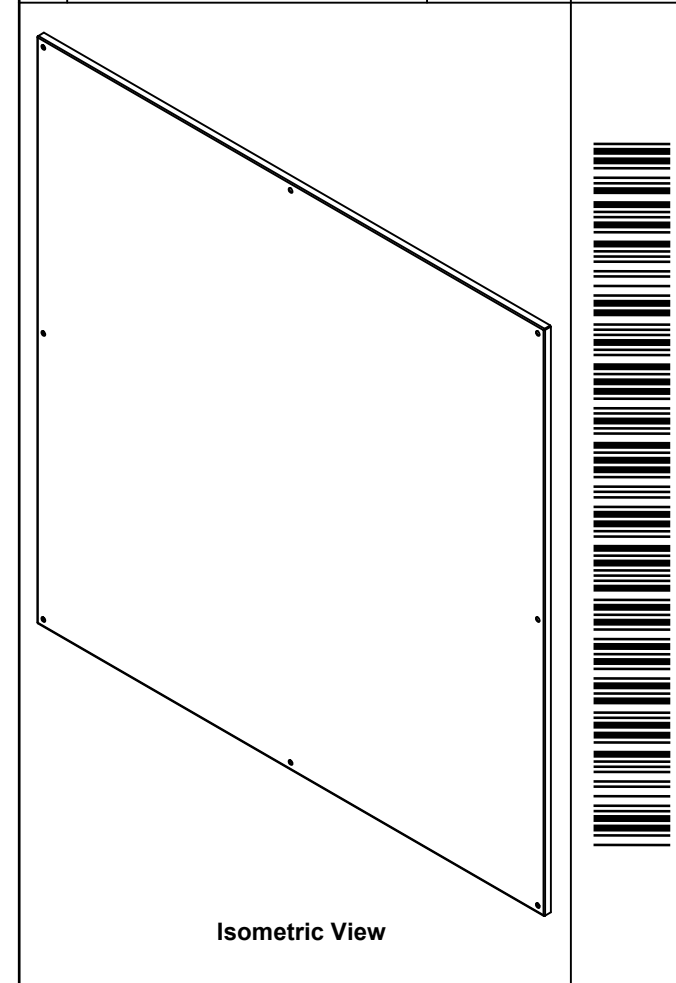

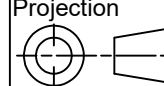
 Tél: (450) 979-4373 Fax: (450) 979-4626 www.exmweb.com		Flatness Aplatissement Max 3.0mm
Customer Client		Projection 
Drawn By Dessiné Par BoxCad		Date 04/11/2009
Material Matière 12 Ga Galvanized (2.5mm)		
Color Couleur Unpainted	Finish Fini Unpainted	
Description 885 SP7272G Inner Panel		Detail Rev.
Part Number Numéro Pièce 885SP7272G		Rev. 2 0

Qty	Part Number	Rev	Description
1	885SP7272G-P	0	885 SP7272G Inner Panel Part
Parts List			