

This drawing is confidential and must not be reproduced or used without the consent of EXM

Ce dessin est confidentiel et ne doit pas être reproduit ou utilisé sans le consentement de EXM

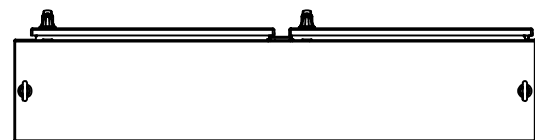

TOP

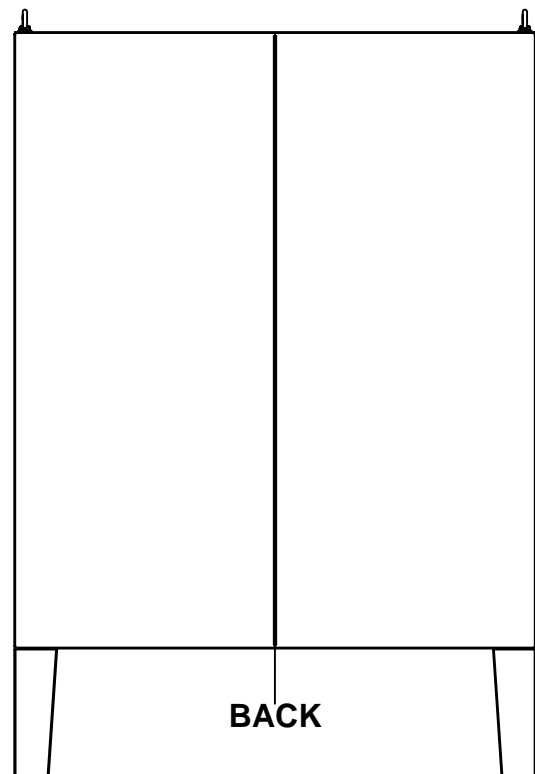

BACK

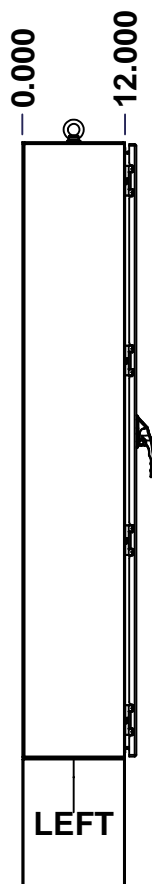

LEFT

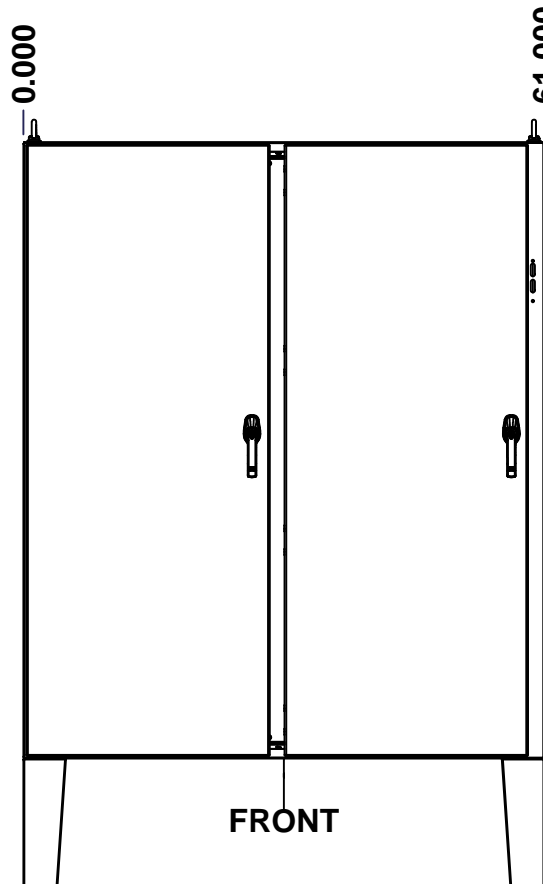

FRONT

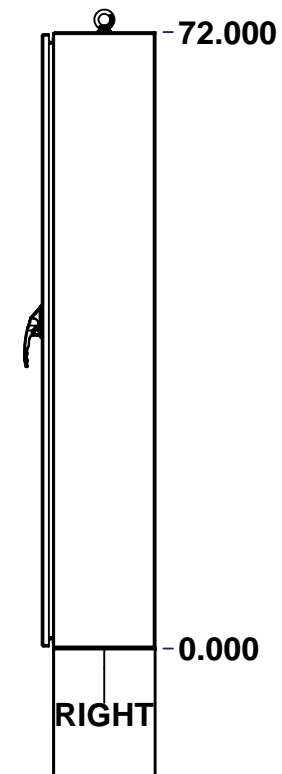

RIGHT

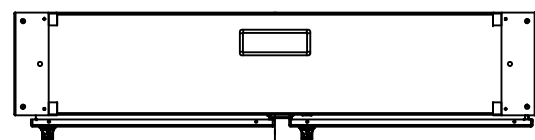

BOTTOM

No.	Revisions	Date	By/Par

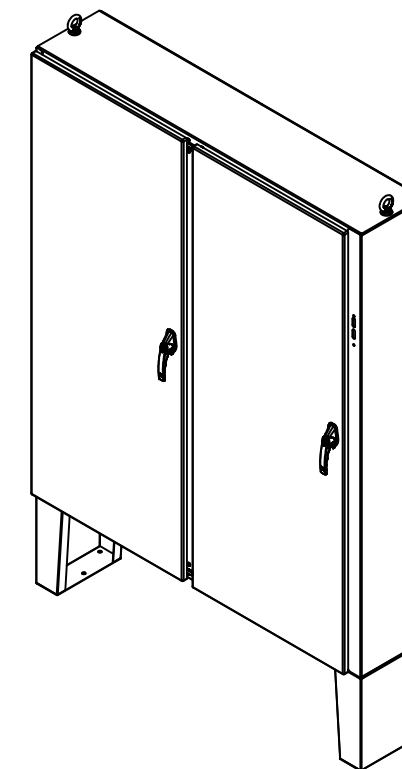

Isometric View



Tél: (450) 979-4373
 Fax: (450) 979-4626
www.exmweb.com

Flatness
Aplatissement

Max 3.0mm

Projection



Customer Client	Date
Drawn By / Dessiné Par: BoxCad: BoxCad	Date: 25-Mar-16
Material / Matière: 12 Ga Stainless Steel 304 (2.5mm)	
Color / Couleur: Asa-61 Grey	Finish / Fini: Smooth

Description: 5500UFDSS 72" x 61" x 12" Assembly	Detail Rev.
---	-------------

Part Number / Numéro Pièce: 5500UFDSS726112	Rev. 1	2
	0	

SEE BILL OF MATERIAL ON LAST PAGE

This drawing is confidential and must not be reproduced or used without the consent of EXM

Ce dessin est confidentiel et ne doit pas être reproduit ou utilisé sans le consentement de EXM

NOTE	
ITEM	DESCRIPTION
1	NEMA 12/13 Enclosure
2	C/W Standard ground studs on box and cover
3	W/O Standard door stiffener
4	C/W Standard inner panel (Included)
5	C/W Standard inner panel mounting studs
6	C/W Special handle sold separately (Kit)
7	C/W Mounting feet sold separately (Installed)
8	C/W Struts installed (Included)
9	C/W Eyebolts

No.	Revisions	Date	By/Par

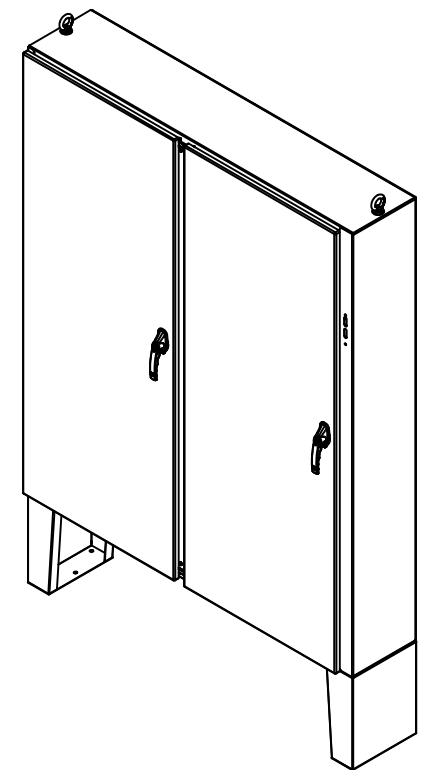

Isometric View



Tél: (450) 979-4373
 Fax: (450) 979-4626
www.exmweb.com

Flatness
Aplatissement
Max 3.0mm
Projection

PACKING		
ITEM	QTY	DESCRIPTION
Cardboard sleeve	2	Top and Bottom
Cardboard strip	2	Between back of enclosure and inner panel
Plastic bag	1	To protect cover surface and inside gasket
Cardboard corner	4	To reinforced for the plastic strap tightening
Plastic strap - Black	2	To Squeeze 2 cardboard sleeve together
Packaging label	3	White label with PN
Plastic strap- Green	2	To secure the enclosure to the wood pallet
Wood Pallet	1	2" deeper and 3" larger than enclosure size

Qty	Part Number	Rev	Description
1	5500UFDSS726112MF	0	885 MFHD 15" x 12" Mounting Feet
1	880INTI	2	880 INTI - Interlock Post Kit
1	5500UFDSS726112GP	0	5500UFDSS Gland Plate
1	880EB14SS	2	Stainless Steel Eye Bolt M14 (Pack of 2)
8	STK-Q-07320	0	Flange Lock Nut M10
1	885SP7260G	0	885 SP7260G Inner Panel
6	STK-Q-07620	0	M10 Plastic Spacer 0.875"
1	5500UFDSS726112FD	0	5500UFDSS 72" x 61" Lock Door
1	5500UFDSS726112LD	0	5500UFDSS 72" x 61" Lock Door
1	5500UFDSS726112B	0	5500UFDSS 72" x 61" x 12" Body
8	STK-Q-04051-10	8	M6 Hexagon Socket Head Machine Screw with Nyseal

Customer Client	Date
Drawn By Dessiné Par	Date 25-Mar-16
Material Matière	12 Ga Stainless Steel 304 (2.5mm)
Color Couleur	Asa-61 Grey
Finish Fini	Smooth
Description	Detail Rev.
5500UFDSS 72" x 61" x 12" Assembly	
Part Number Numéro Pièce	Rev. 2
5500UFDSS726112	0

Parts List

This drawing is confidential and must not be reproduced or used without the consent of EXM

Ce dessin est confidentiel et ne doit pas être reproduit ou utilisé sans le consentement de EXM

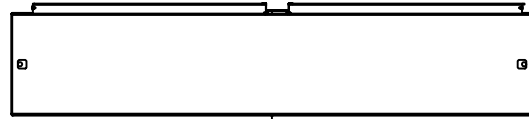

TOP

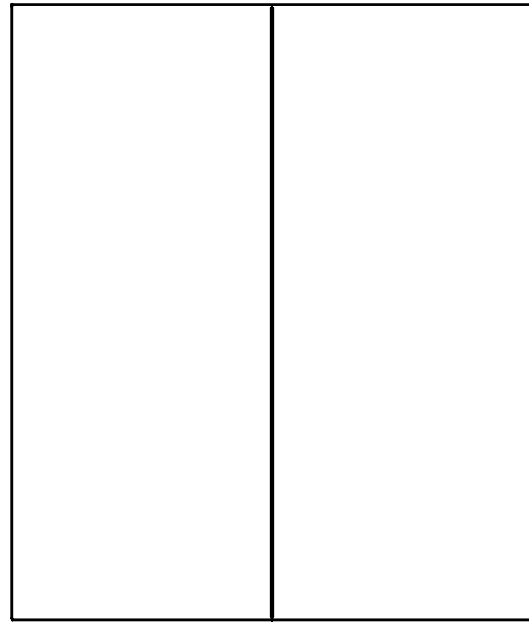

BACK

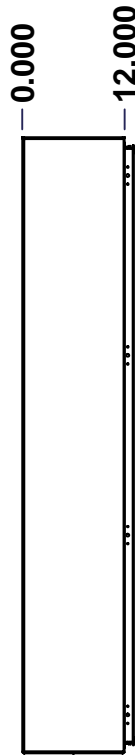

LEFT

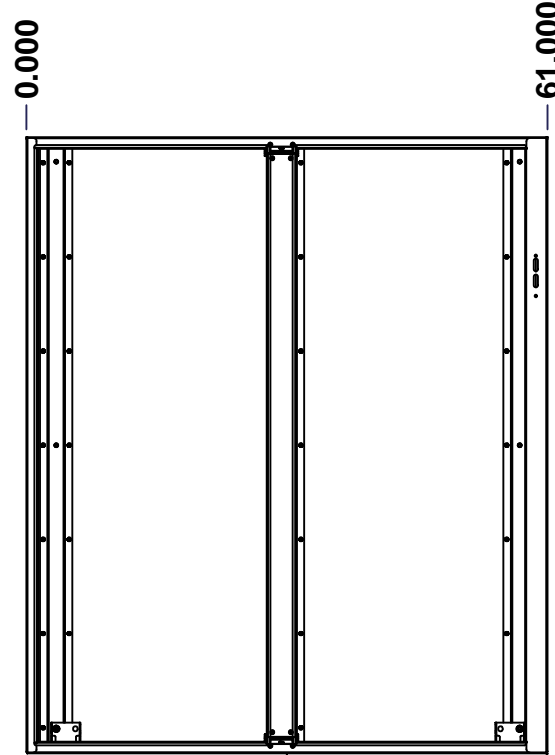

FRONT

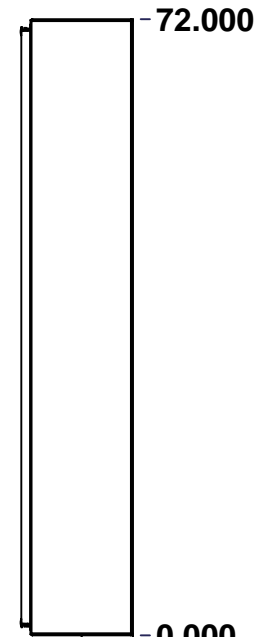

RIGHT

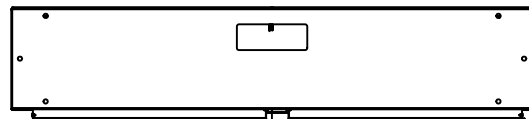

BOTTOM

No.	Revisions	Date	By/Par

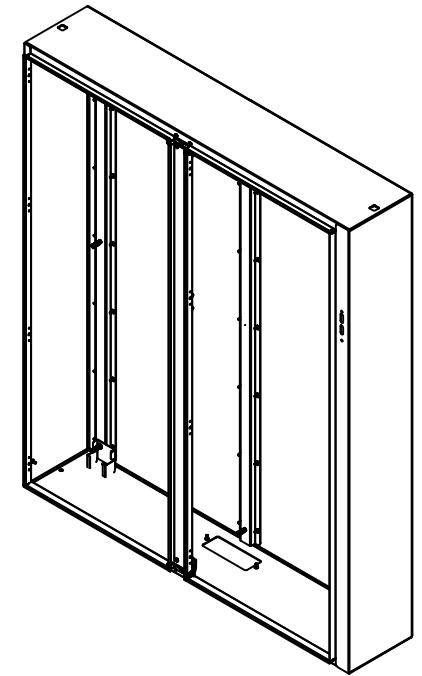

Isometric View



Tél: (450) 979-4373
 Fax: (450) 979-4626
www.exmweb.com

Flatness
Aplatissement

Max 3.0mm

Projection

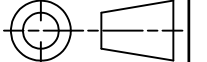

Customer Client	Date
Drawn By Dessiné Par BoxCad: BoxCad	Date 25-Mar-16
Material Matière 12 Ga Stainless Steel 304 (2.5mm)	
Color Couleur Asa-61 Grey	Finish Fini Smooth
Description 5500UFDSS 72" x 61" x 12" Body	Detail Rev.
Part Number Numéro Pièce 5500UFDSS726112B	Rev. 1 0 2

SEE BILL OF MATERIAL ON LAST PAGE

This drawing is confidential and must not be reproduced or used without the consent of EXM

Ce dessin est confidentiel et ne doit pas être reproduit ou utilisé sans le consentement de EXM

STANDARD FEATURES ARE NOT LISTED IN THIS HOLE TABLE

HOLE TABLE - TOP VIEW (CUSTOM FEATURE ONLY)

CUT-OUT	XDIM	YDIM	DESCRIPTION
1	45.895	7.895	Struts CR400 21.500" (Inside)
2	14.895	7.895	Struts CR400 21.500" (Inside)
3	45.895	7.895	STUDS M6 x 10mm (Inside)
4	38.145	7.895	STUDS M6 x 10mm (Inside)
5	53.645	7.895	STUDS M6 x 10mm (Inside)
6	14.895	7.895	STUDS M6 x 10mm (Inside)
7	7.145	7.895	STUDS M6 x 10mm (Inside)
8	22.645	7.895	STUDS M6 x 10mm (Inside)

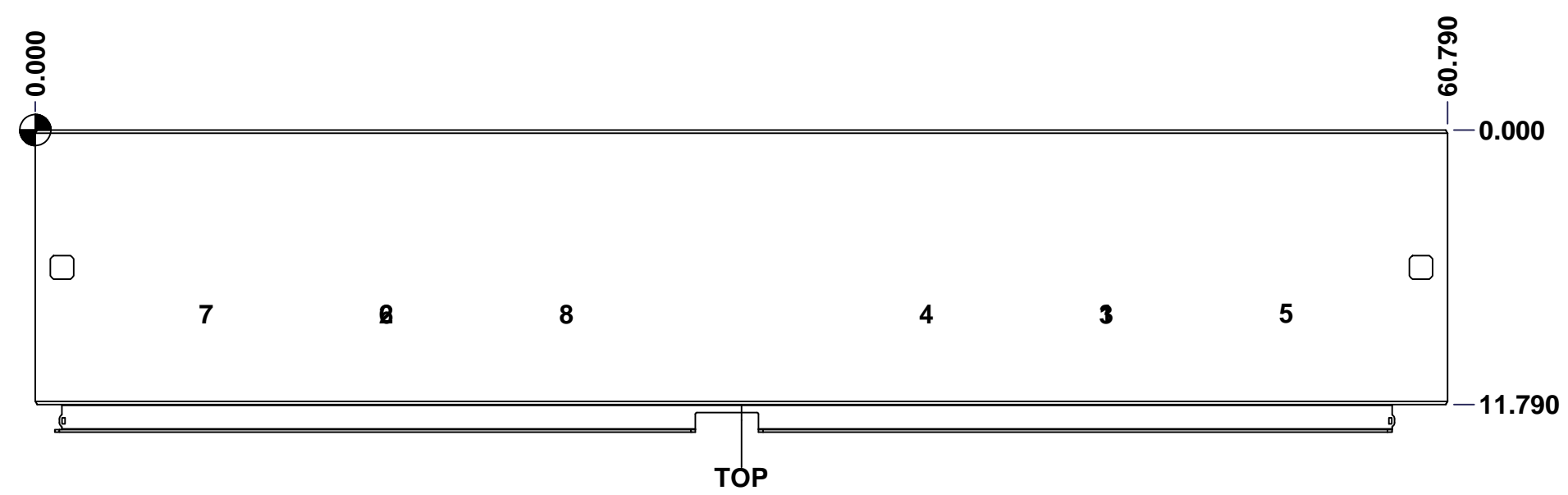

	Description	Status	
	5500UFDSS 72" x 61" x 12" Body	Released	
	Part Number Numéro Pièce	Rev.	
	5500UFDSS726112B	0	2 / 7

This drawing is confidential and must not be reproduced or used without the consent of EXM

Ce dessin est confidentiel et ne doit pas être reproduit ou utilisé sans le consentement de EXM

STANDARD FEATURES ARE NOT LISTED IN THIS HOLE TABLE

HOLE TABLE - BOTTOM VIEW (CUSTOM FEATURE ONLY)

CUT-OUT	XDIM	YDIM	DESCRIPTION
1	25.770	3.395	GP STUD M6 x 16mm (Inside)
2	35.020	3.395	GP STUD M6 x 16mm (Inside)

3	3.895	0.895	RND Ø0.500
4	0.895	5.895	RND Ø0.500
5	3.895	10.895	RND Ø0.500
6	56.895	0.895	RND Ø0.500
7	59.895	5.895	RND Ø0.500
8	56.895	10.895	RND Ø0.500

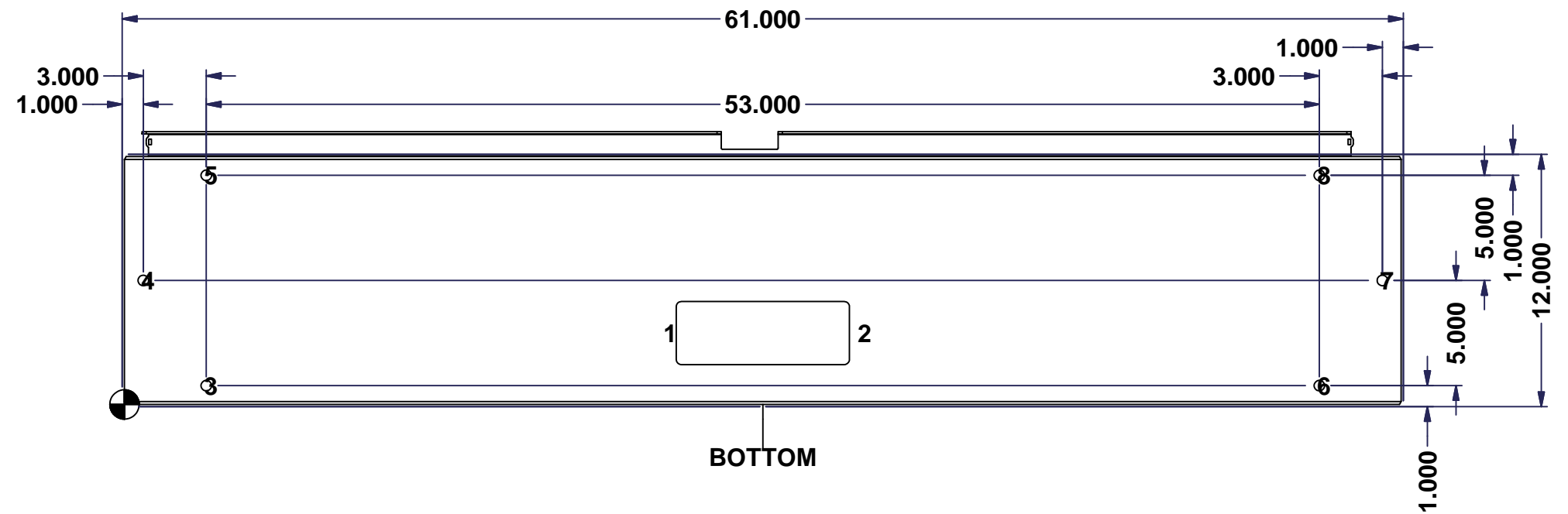

BOTTOM

	Description	Status
	5500UFDSS 72" x 61" x 12" Body	Released
	Part Number Numéro Pièce	Rev.
	5500UFDSS726112B	0
		4
		7

This drawing is confidential and must not be reproduced or used without the consent of EXM

Ce dessin est confidentiel et ne doit pas être reproduit ou utilisé sans le consentement de EXM

STANDARD FEATURES ARE NOT LISTED IN THIS HOLE TABLE			
HOLE TABLE - LEFT VIEW (CUSTOM FEATURE ONLY)			
CUT-OUT	XDIM	YDIM	DESCRIPTION
1	10.395	3.270	GND STUD M6 x 16mm (Inside)

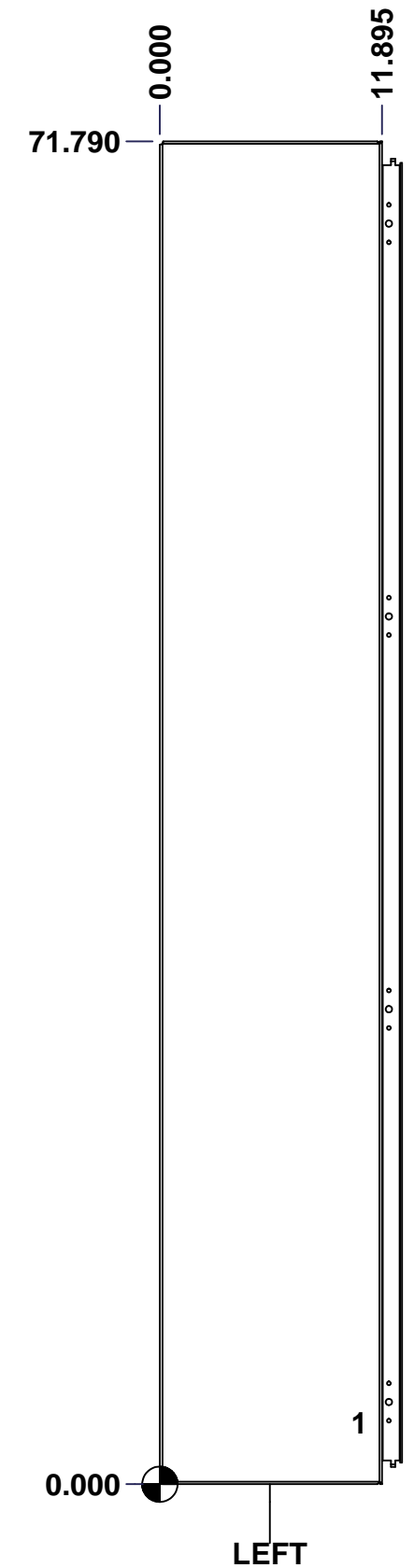

	Description	Status
	5500UFDSS 72" x 61" x 12" Body	Released
	Part Number Numéro Pièce	Rev.
	5500UFDSS726112B	0
		5
		7

This drawing is confidential and must not be reproduced or used without the consent of EXM

Ce dessin est confidentiel et ne doit pas être reproduit ou utilisé sans le consentement de EXM

STANDARD FEATURES ARE NOT LISTED IN THIS HOLE TABLE			
HOLE TABLE - BACK VIEW (CUSTOM FEATURE ONLY)			
CUT-OUT	XDIM	YDIM	DESCRIPTION
1	1.730	3.000	STUDS M6 x 18mm (Inside)
2	1.730	14.000	STUDS M6 x 18mm (Inside)
3	1.730	25.000	STUDS M6 x 18mm (Inside)
4	1.730	36.000	STUDS M6 x 18mm (Inside)
5	1.730	47.000	STUDS M6 x 18mm (Inside)
6	1.730	58.000	STUDS M6 x 18mm (Inside)
7	1.730	69.000	STUDS M6 x 18mm (Inside)
8	4.770	3.000	STUDS M6 x 18mm (Inside)
9	4.770	14.000	STUDS M6 x 18mm (Inside)
10	4.770	25.000	STUDS M6 x 18mm (Inside)
11	4.770	36.000	STUDS M6 x 18mm (Inside)
12	4.770	47.000	STUDS M6 x 18mm (Inside)
13	4.770	58.000	STUDS M6 x 18mm (Inside)
14	4.770	69.000	STUDS M6 x 18mm (Inside)
15	28.855	3.000	STUDS M6 x 18mm (Inside)
16	28.855	14.000	STUDS M6 x 18mm (Inside)
17	28.855	25.000	STUDS M6 x 18mm (Inside)
18	28.855	36.000	STUDS M6 x 18mm (Inside)
19	28.855	47.000	STUDS M6 x 18mm (Inside)
20	28.855	58.000	STUDS M6 x 18mm (Inside)
21	28.855	69.000	STUDS M6 x 18mm (Inside)
22	31.895	3.000	STUDS M6 x 18mm (Inside)
23	31.895	14.000	STUDS M6 x 18mm (Inside)
24	31.895	25.000	STUDS M6 x 18mm (Inside)
25	31.895	36.000	STUDS M6 x 18mm (Inside)
26	31.895	47.000	STUDS M6 x 18mm (Inside)
27	31.895	58.000	STUDS M6 x 18mm (Inside)
28	31.895	69.000	STUDS M6 x 18mm (Inside)
29	55.980	3.000	STUDS M6 x 18mm (Inside)
30	55.980	14.000	STUDS M6 x 18mm (Inside)
31	55.980	25.000	STUDS M6 x 18mm (Inside)
32	55.980	36.000	STUDS M6 x 18mm (Inside)
33	55.980	47.000	STUDS M6 x 18mm (Inside)
34	55.980	58.000	STUDS M6 x 18mm (Inside)
35	55.980	69.000	STUDS M6 x 18mm (Inside)
36	59.020	3.000	STUDS M6 x 18mm (Inside)
37	59.020	14.000	STUDS M6 x 18mm (Inside)
38	59.020	25.000	STUDS M6 x 18mm (Inside)
39	59.020	36.000	STUDS M6 x 18mm (Inside)
40	59.020	47.000	STUDS M6 x 18mm (Inside)
41	59.020	58.000	STUDS M6 x 18mm (Inside)
42	59.020	69.000	STUDS M6 x 18mm (Inside)

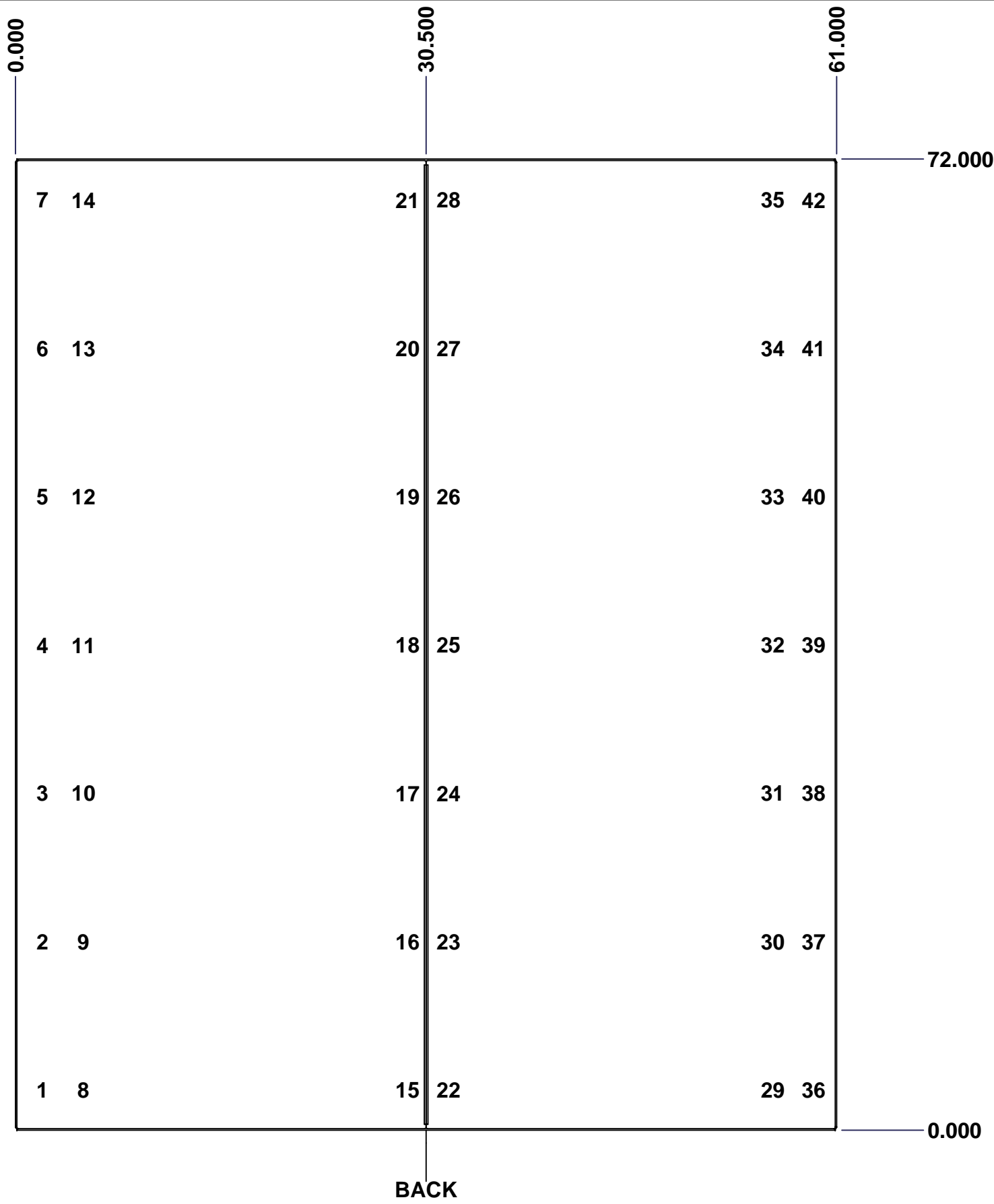

	Description	Status	
	5500UFDSS 72" x 61" x 12" Body	Released	
	Part Number Numéro Pièce	Rev.	
	5500UFDSS726112B	0	6 7

This drawing is confidential and must not be reproduced or used without the consent of EXM

Ce dessin est confidentiel et ne doit pas être reproduit ou utilisé sans le consentement de EXM

STANDARD FEATURES ARE NOT LISTED IN THIS HOLE TABLE			
HOLE TABLE - CENTER VIEW (CUSTOM FEATURE ONLY)			
CUT-OUT	XDIM	YDIM	DESCRIPTION
1	0.748	42.220	INTERLOCK STUD M6 x 16mm (Inside)
2	0.748	44.346	INTERLOCK STUD M6 x 16mm (Inside)
3	2.717	42.220	INTERLOCK STUD M6 x 16mm (Inside)
4	2.717	44.346	INTERLOCK STUD M6 x 16mm (Inside)
5	1.732	3.648	GND STUD M6 x 16mm (Inside)

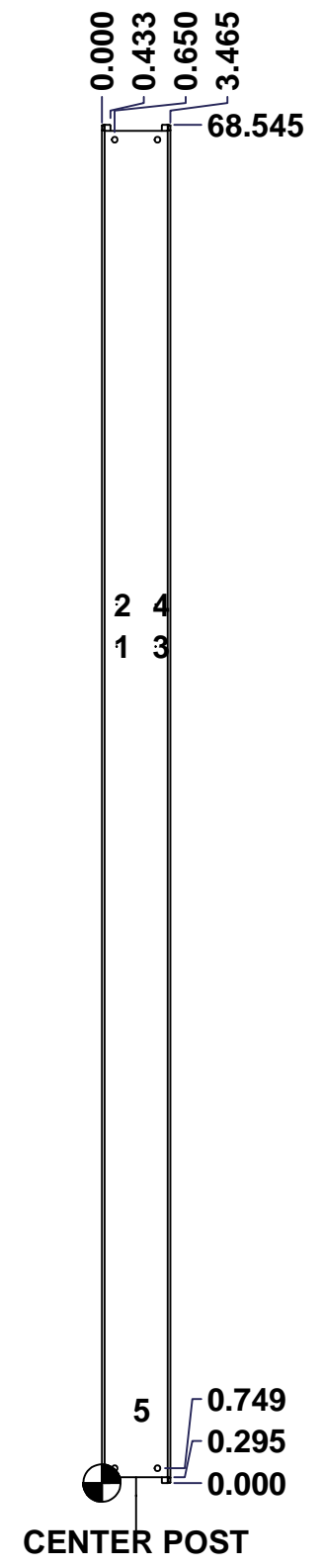

	Description	Status
	5500UFDSS 72" x 61" x 12" Body	Released
	Part Number Numéro Pièce	Rev.
	5500UFDSS726112B	0
		6 7

This drawing is confidential and must not be reproduced or used without the consent of EXM

Ce dessin est confidentiel et ne doit pas être reproduit ou utilisé sans le consentement de EXM

STANDARD FEATURES ARE NOT LISTED IN THIS HOLE TABLE

HOLE TABLE - CENTER VIEW (CUSTOM FEATURE ONLY)

CUT-OUT	XDIM	YDIM	DESCRIPTION
1	1.895	2.262	IP STUD M10 x 40mm (Outside)
2	1.895	35.387	IP STUD M10 x 40mm (Outside)
3	1.895	68.512	IP STUD M10 x 40mm (Outside)

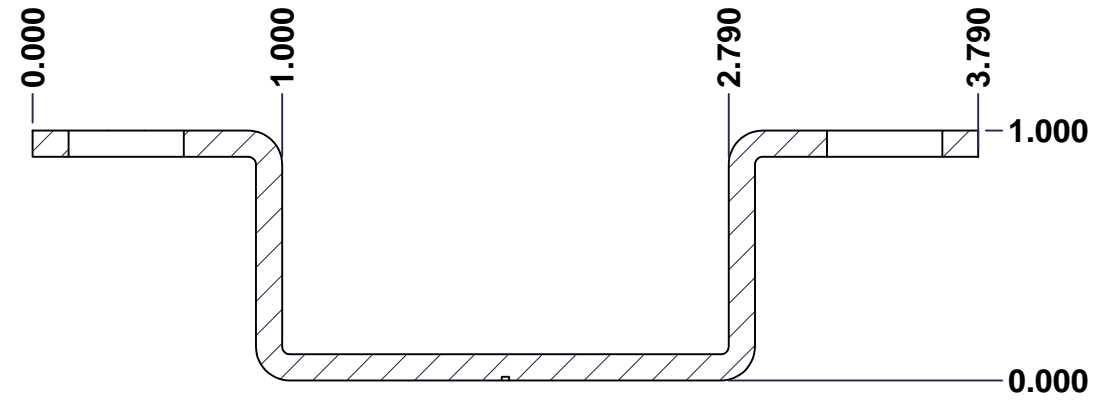
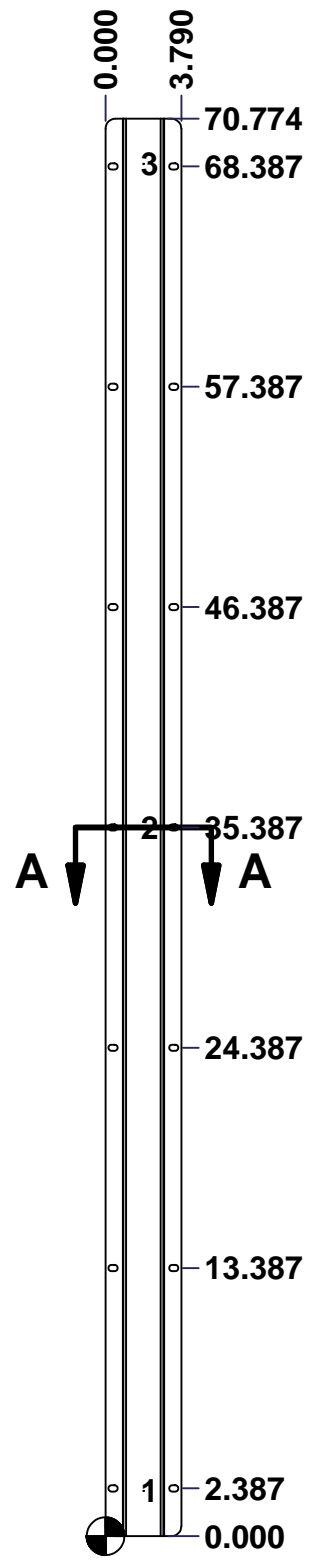

SECTION A-A

	Description	Status	
	5500UFDSS 72" x 61" x 12" Body	Released	
	Part Number Numéro Pièce	Rev.	
	5500UFDSS726112B	0	6 7

This drawing is confidential and must not be reproduced or used without the consent of EXM

Ce dessin est confidentiel et ne doit pas être reproduit ou utilisé sans le consentement de EXM

No.	Revisions	Date	By/Par

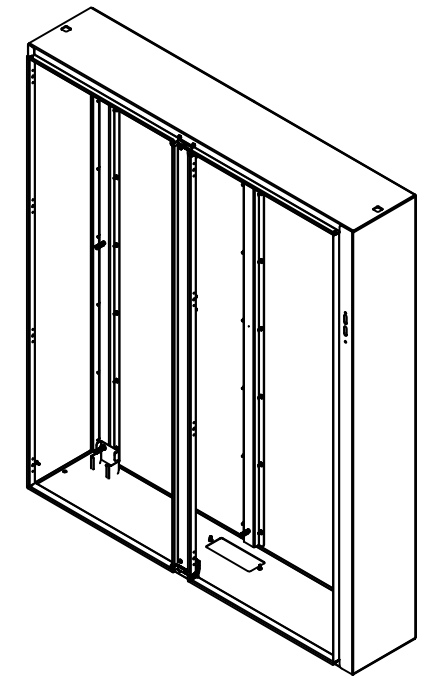

Isometric View



6	STK-Q-16040	0	Stud M6 x 10mm Stainless Steel
1	STK-Q-16085	0	Ground Stud M6 x 16mm Stainless Steel
1	STK-P-02400S	0	Powder Paint (Asa-61 Grey / Smooth)
3	STK-Q-16095	0	M6 x 16mm Stainless Steel Ground Stud
46	STK-Q-16070	1	Stud M6 x 18mm Stainless Steel
1	STK-A-75456	2	Center Post - Stainless Steel Sealing Block with Latch Assembly (Large)
1	5500UFDSS726112CP-P	0	5500UFDSS 72" Center Post Part
8	STK-Q-16120	0	Stud M10 x 40mm Stainless Steel
2	STK-Q-07320	0	Flange Lock Nut M10
2	STK-Q-07618	1	5500 Series Inner Panel Support Bracket
3	5500UFDSS726112POST-P	0	5500UFDSS 72" IP Post Part
1	5500UFDSS726112BT-P	0	5500UFDSS 61" x 12" Bottom Part
1	5500UFDSS726112T-P	0	5500UFDSS 61" x 12" Top Part
1	5500UFDSS726112RS-P	0	5500UFDSS 72" x 61" Right Part
1	5500UFDSS726112LS-P	0	5500UFDSS 72" x 61" Left Part
1	5500UFDSS726112BR-P	0	5500UFDSS 72" x 61" Back Right Part
1	5500UFDSS726112BL-P	0	5500UFDSS 72" x 61" Back Left Part
2	CR400SS_21.5	0	Commercial Roll Stainless Steel (21.5in long)
48	STK-Q-07220	1	M6 Nylon Insert Lock Nut

Qty	Part Number	Rev	Description
Parts List			

Tél: (450) 979-4373 Fax: (450) 979-4626 www.exmweb.com		Flatness Aplatissement Max 3.0mm Projection
Customer Client	Date	
Drawn By Dessiné Par	BoxCad: BoxCad	Date 25-Mar-16
Material Matière	12 Ga Stainless Steel 304 (2.5mm)	
Color Couleur	Asa-61 Grey	Finish Fini Smooth
Description		Detail Rev.
5500UFDSS 72" x 61" x 12" Body		
Part Number Numéro Pièce	Rev.	2
5500UFDSS726112B	0	2

This drawing is confidential and must not be reproduced or used without the consent of EXM

Ce dessin est confidentiel et ne doit pas être reproduit ou utilisé sans le consentement de EXM

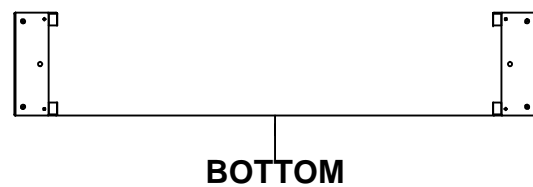
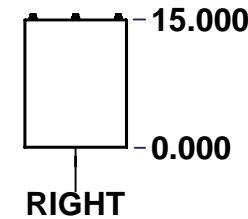
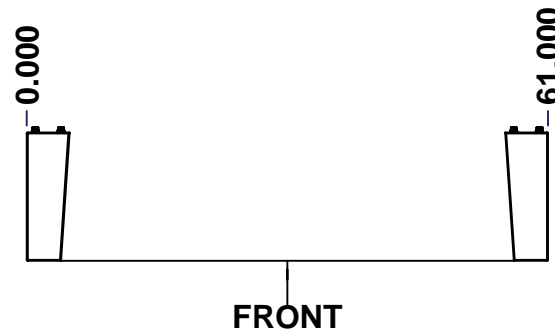
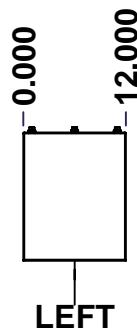
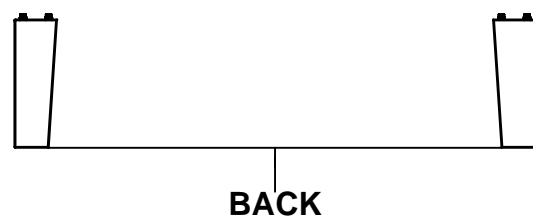
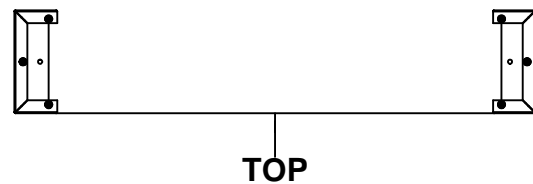

No.	Revisions	Date	By/Par

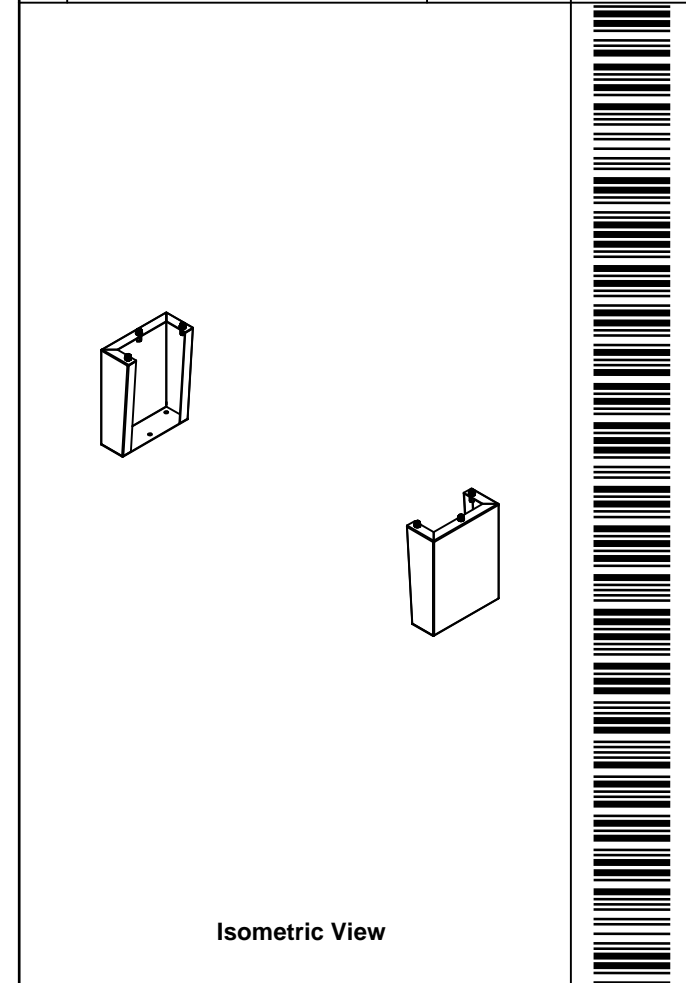

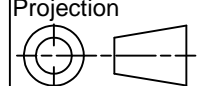
 Tél: (450) 979-4373 Fax: (450) 979-4626 www.exmweb.com		Flatness Aplatissement Max 3.0mm Projection 
Customer Client	Date	
Drawn By / Dessiné Par: BoxCad: BoxCad	Date: 25-Mar-16	
Material / Matière: 12 Ga Stainless Steel 304 (2.5mm)	Color / Couleur: Asa-61 Grey	
Description: 885 MFHD 15" x 12" Mounting Feet		Finish / Fini: Smooth
Part Number / Numéro Pièce: 5500UFDSS726112MF	Rev. 0	1 / 4

SEE BILL OF MATERIAL ON LAST PAGE

This drawing is confidential and must not be reproduced or used without the consent of EXM

Ce dessin est confidentiel et ne doit pas être reproduit ou utilisé sans le consentement de EXM

No.	Revisions	Date	By/Par

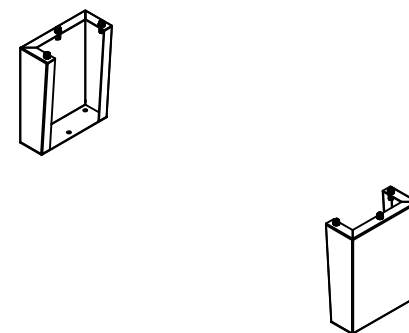

Isometric View



Tél: (450) 979-4373
 Fax: (450) 979-4626
www.exmweb.com

Flatness
Aplatissement
Max 3.0mm
Projection

Customer Client	Date
Drawn By / Dessiné Par: BoxCad: BoxCad	Date: 25-Mar-16

Material / Matière: 12 Ga Stainless Steel 304 (2.5mm)

Color / Couleur: Asa-61 Grey	Finish / Fini: Smooth
------------------------------	-----------------------

Description: 885 MFHD 15" x 12" Mounting Feet	Detail Rev.
---	-------------

Part Number / Numéro Pièce: 5500UFDSS726112MF	Rev. 0	4
--	---------------	---

Qty	Part Name	Rev	Description
1	STK-P-02400S	0	Powder Paint (Asa-61 Grey / Smooth)
6	RIVET_NUT_SS_M10_FH_CE	0	Stainless Steel Rivet Nut M10 (Low Profile Close End)
1	5500UFDSS726112MFR-P	0	885 MFHD 15" x 12" Right Mounting Feet Part
1	5500UFDSS726112MFL-P	0	885 MFHD 15" x 12" Left Mounting Feet Part
1	STK-K-11610	2	885 MFSS Accessory Kit
Parts List			

This drawing is confidential and must not be reproduced or used without the consent of EXM

Ce dessin est confidentiel et ne doit pas être reproduit ou utilisé sans le consentement de EXM



TOP

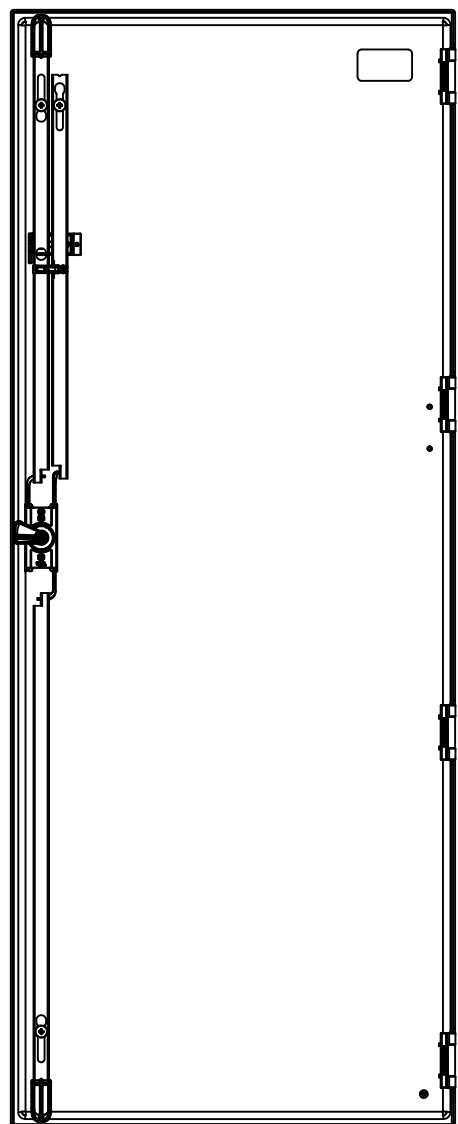

BACK



BOTTOM

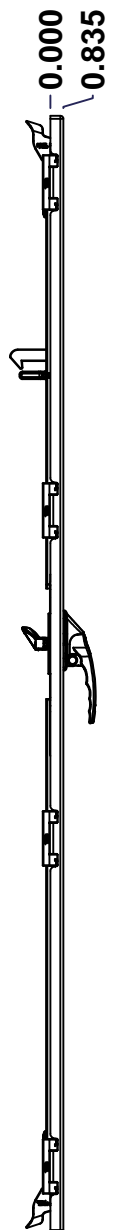

LEFT

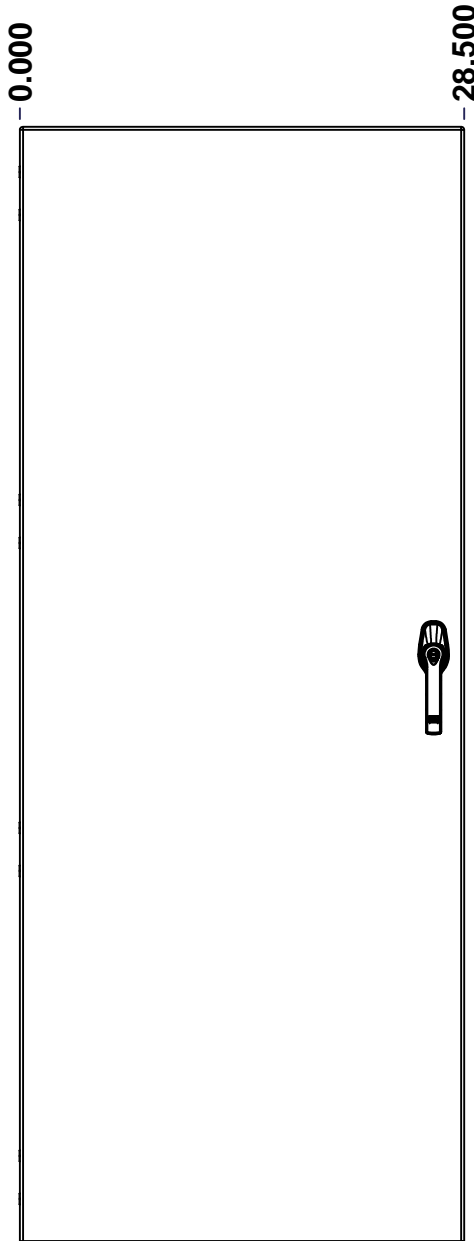

FRONT

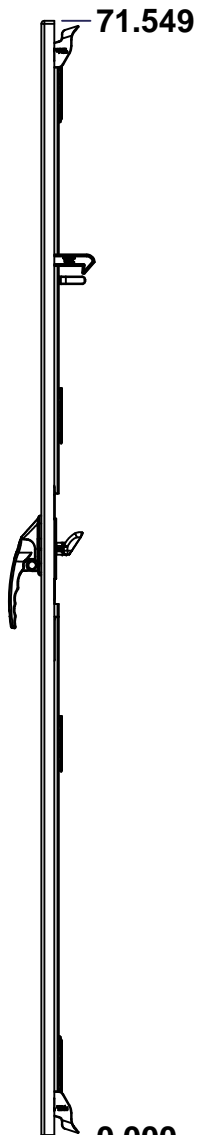

RIGHT

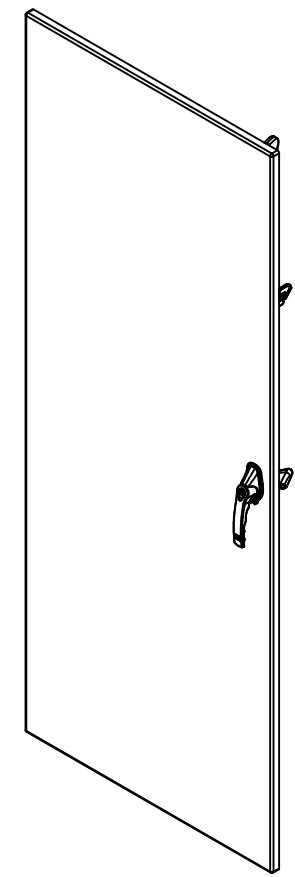

Isometric View

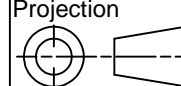

No.	Revisions	Date	By/Par

 Tél: (450) 979-4373 Fax: (450) 979-4626 www.exmweb.com		Flatness Aplatissement Max 3.0mm Projection 
Customer Client	Date	
Drawn By / Dessiné Par: BoxCad: BoxCad	Date: 25-Mar-16	
Material / Matière: 12 Ga Stainless Steel 304 (2.5mm)	Color / Couleur: Asa-61 Grey	
Description: 5500UFDSS 72" x 61" Lock Door		Finish / Fini: Smooth
Part Number / Numéro Pièce: 5500UFDSS726112LD	Detail Rev.:	Rev. 1 / 3

SEE BILL OF MATERIAL ON LAST PAGE

This drawing is confidential and must not be reproduced or used without the consent of EXM

Ce dessin est confidentiel et ne doit pas être reproduit ou utilisé sans le consentement de EXM

STANDARD FEATURES ARE NOT LISTED IN THIS HOLE TABLE

HOLE TABLE - FRONT VIEW (CUSTOM FEATURE ONLY)

CUT-OUT	XDIM	YDIM	DESCRIPTION
1	26.544	6.118	STUD M6 x 18mm (Inside)
2	26.544	65.430	STUD M6 x 18mm (Inside)
3	25.357	65.430	STUD M6 x 18mm (Inside)
4	26.544	56.525	STUD M6 x 18mm (Inside)
5	25.357	56.525	STUD M6 x 18mm (Inside)
-----	-----	-----	-----
6	2.000	2.118	GND STUD M6 x 16mm (Inside)
7	26.544	37.743	HANDLE 885 ESL2A-APHDSS @ 0.0°
8	1.625	43.445	STUDS M6 x 18mm (Inside)
9	1.625	46.123	STUDS M6 x 18mm (Inside)

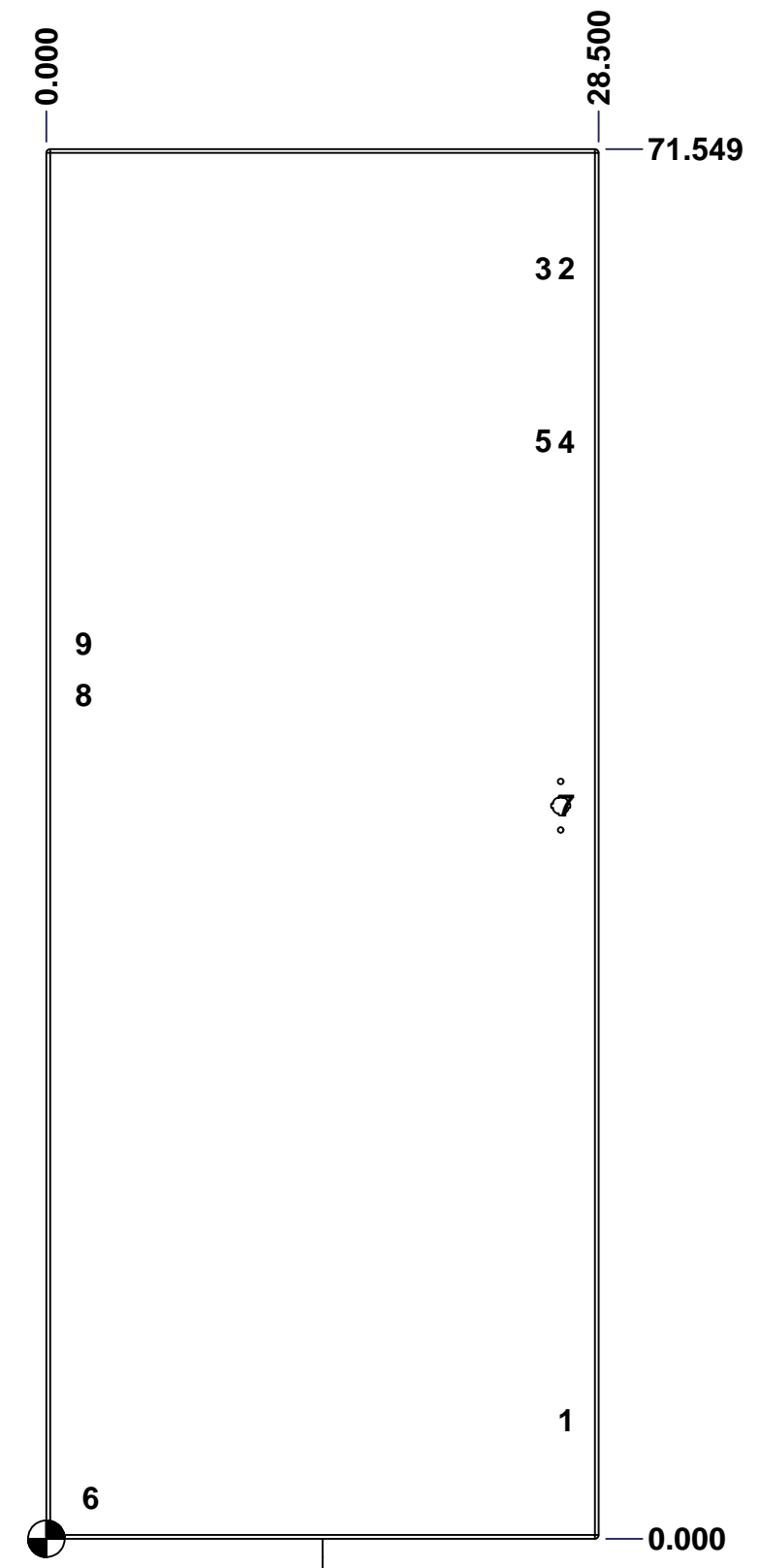

FRONT

	Description	Status	
	5500UFDSS 72" x 61" Lock Door	(NULL)	
	Part Number Numéro Pièce	Rev.	
	5500UFDSS726112LD	0	2 3

This drawing is confidential and must not be reproduced or used without the consent of EXM

Ce dessin est confidentiel et ne doit pas être reproduit ou utilisé sans le consentement de EXM

No.	Revisions	Date	By/Par

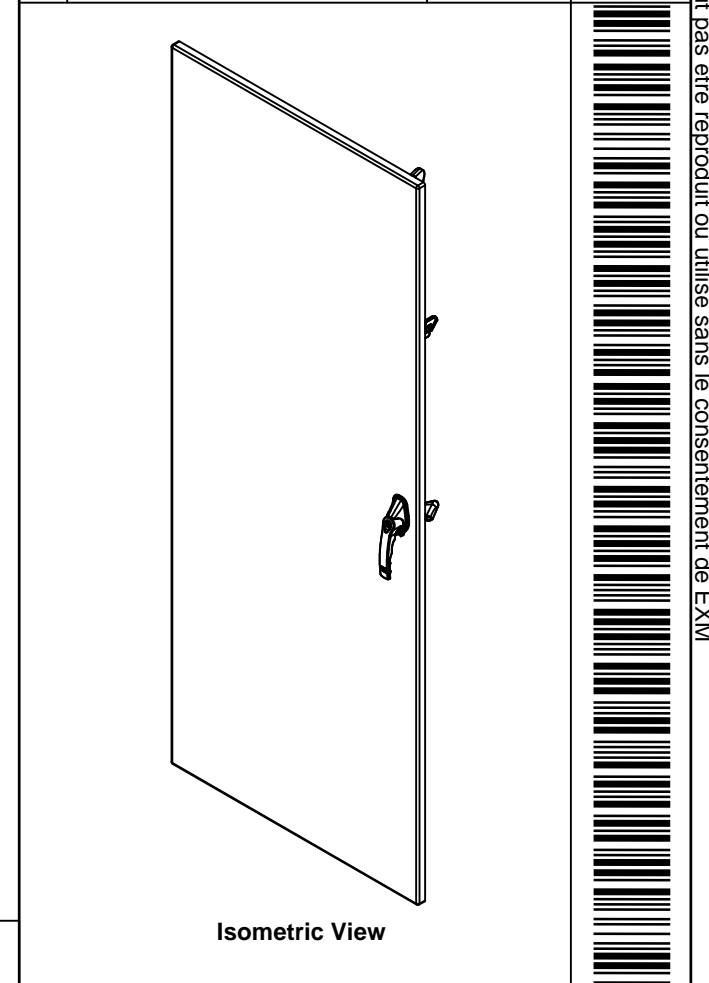

Isometric View

1	5500UFDSS726112DB_ESY	0	5500UFDSS 72" Disconnect Defeater Bar
1	5500UFDSS726112CB	0	5500UFDSS 72" Closing Bar
1	5500UFDSS726112CB_ESY	0	5500UFDSS 72" Disconnect Closing Bar
1	STK-K-03895-36	3	Gearbox Clockwise Assembly (Grip 36mm)
1	885ESL-APHDSS	1	885 ESL2A-APHDSS - Stainless Steel L-Handle Padlockable Assy - Slot Cylinder
1	STK-Q-16085	0	Ground Stud M6 x 16mm Stainless Steel
1	STK-P-02400S	0	Powder Paint (Asa-61 Grey / Smooth)
1	STK-S-00100	0	3.5" x 2" Silver Milar Flexcon Sticker
1	STK-Q-07220	1	M6 Nylon Insert Lock Nut
1	5500UFDSS726112LDG	0	5500UFDSS 72" x 61" Lock Door Gasket
1	STK-Q-13060	1	M6 Flat Washer
1	STK-Q-46600	3	5500 ESY Disconnect Door Hook
7	STK-Q-16070	1	Stud M6 x 18mm Stainless Steel
1	5500UFDSS726112LD-P	0	5500UFDSS 72" x 61" Lock Door Part
4	STK-K-09870	7	Cabinet Hinge with Captive Pins
Qty	Part Name	Rev	Description

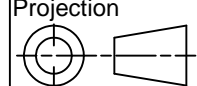
 Tél: (450) 979-4373 Fax: (450) 979-4626 www.exmweb.com	Flatness Aplatissement
	Max 3.0mm
Projection	
Customer Client	Date
Drawn By Dessiné Par	Date 25-Mar-16
Material Matière	12 Ga Stainless Steel 304 (2.5mm)
Color Couleur	Asa-61 Grey
Finish Fini	Smooth
Description	Detail Rev.
5500UFDSS 72" x 61" Lock Door	
Part Number Numéro Pièce	Rev. 3
5500UFDSS726112LD	0

Parts List

This drawing is confidential and must not be reproduced or used without the consent of EXM

Ce dessin est confidentiel et ne doit pas être reproduit ou utilisé sans le consentement de EXM

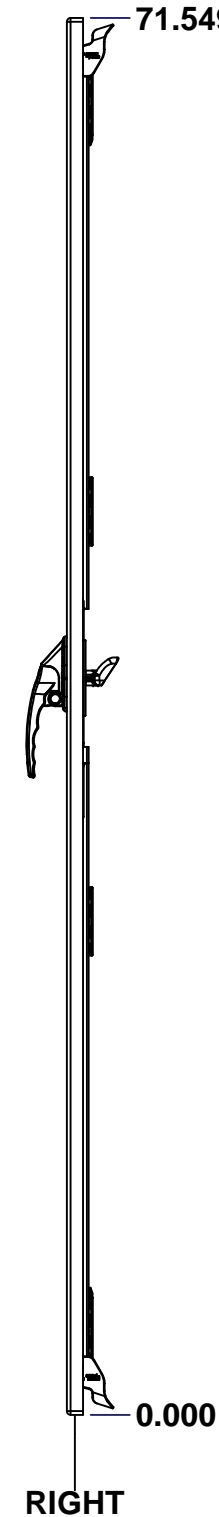
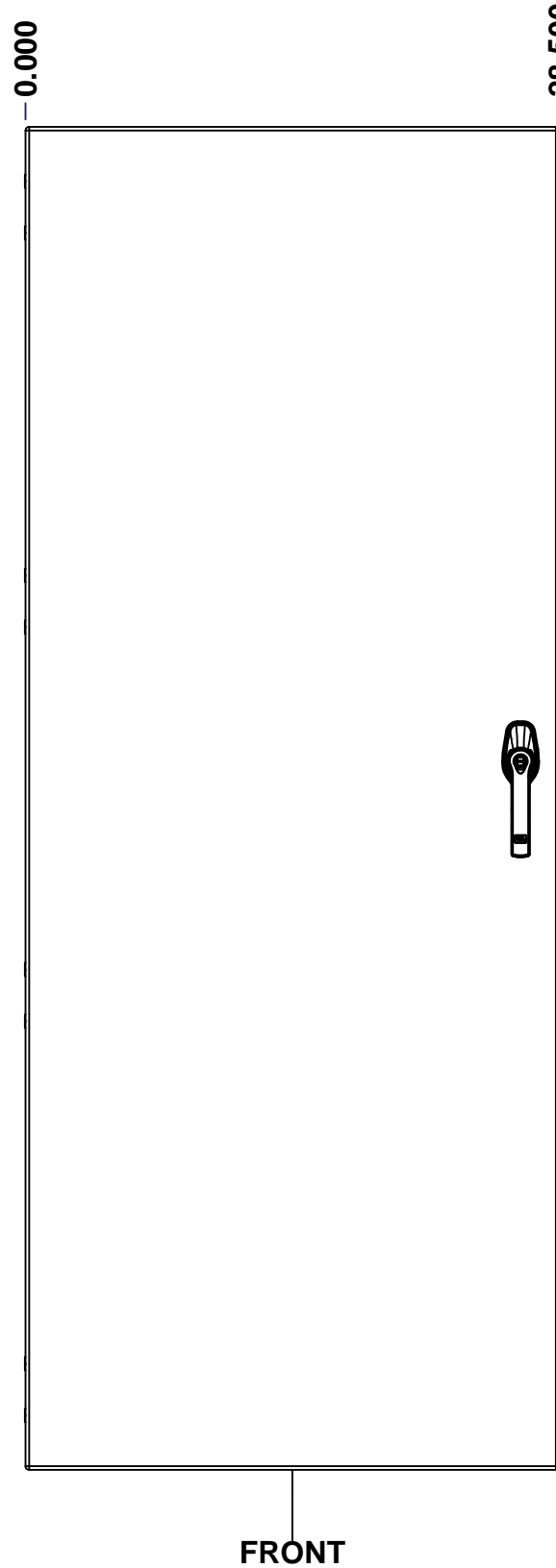
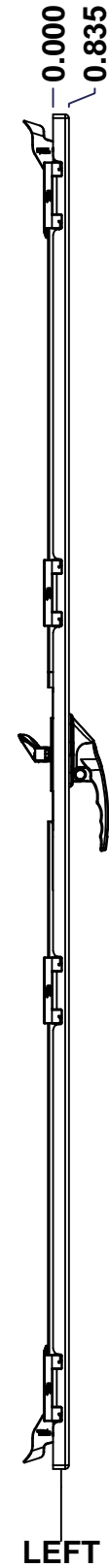
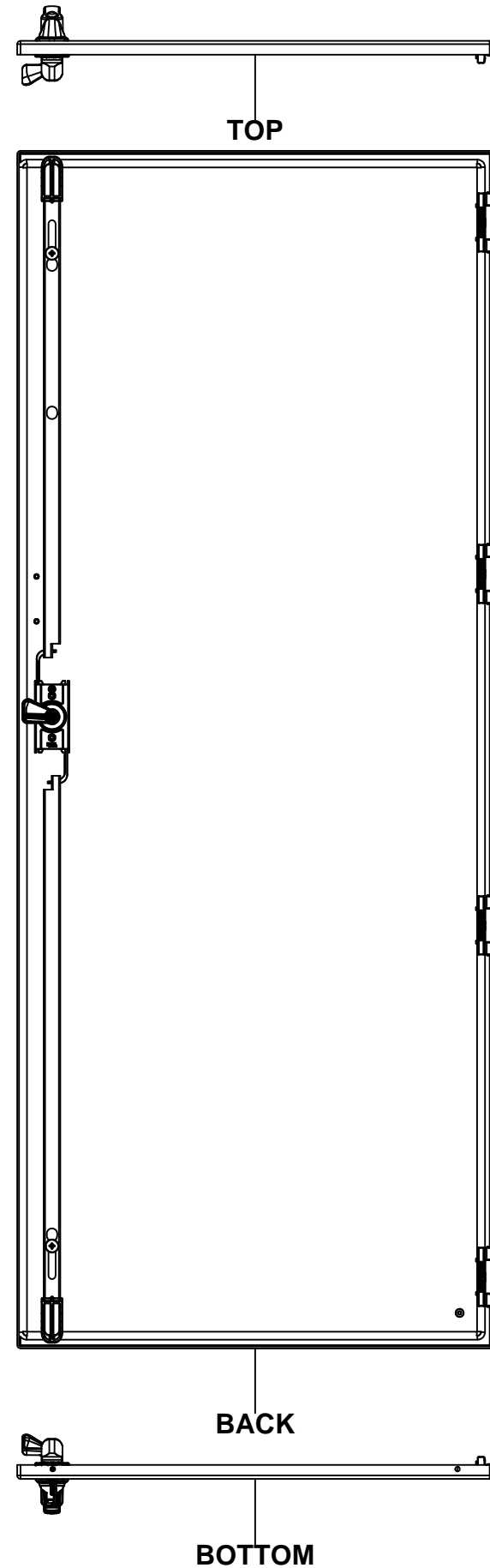

No.	Revisions	Date	By/Par

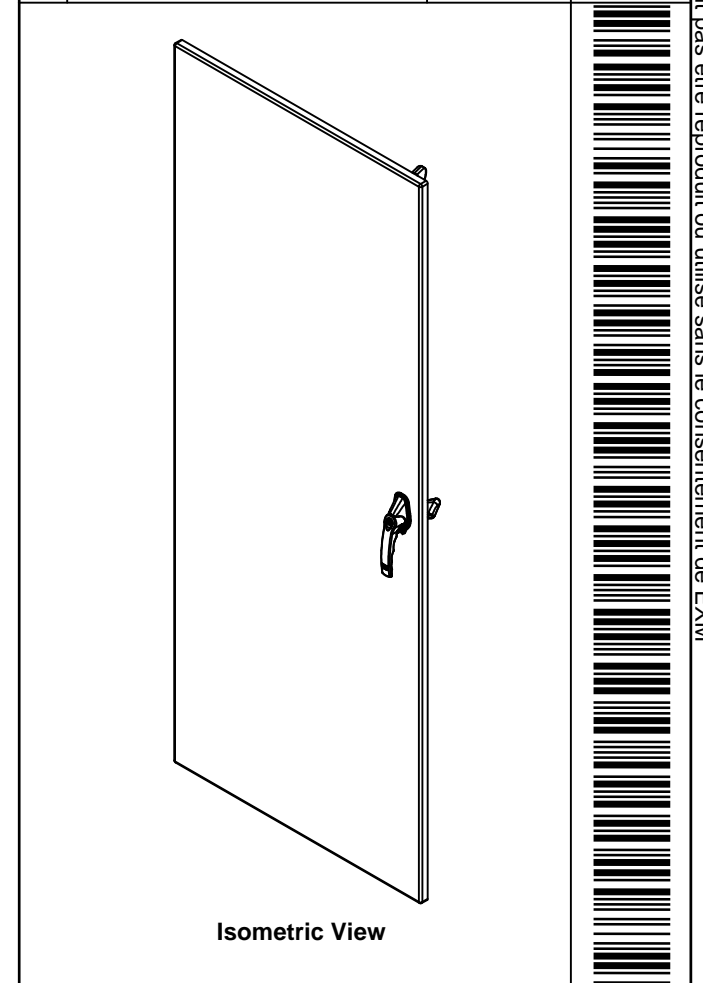

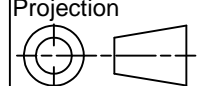
 Tél: (450) 979-4373 Fax: (450) 979-4626 www.exmweb.com		Flatness Aplatissement	
		Max 3.0mm	
Customer Client		Date	
Drawn By Dessiné Par BoxCad: BoxCad		Date 25-Mar-16	
Material Matière 12 Ga Stainless Steel 304 (2.5mm)		Projection	
Color Couleur Asa-61 Grey		 Finish Fini Smooth	
Description 5500UFDSS 72" x 61" Lock Door		Detail Rev.	
Part Number Numéro Pièce 5500UFDSS726112FD		Rev. 0	1 3

SEE BILL OF MATERIAL ON LAST PAGE

This drawing is confidential and must not be reproduced or used without the consent of EXM

Ce dessin est confidentiel et ne doit pas être reproduit ou utilisé sans le consentement de EXM

STANDARD FEATURES ARE NOT LISTED IN THIS HOLE TABLE

HOLE TABLE - FRONT VIEW (CUSTOM FEATURE ONLY)

CUT-OUT	XDIM	YDIM	DESCRIPTION
1	26.419	6.118	CLOSING BAR GUIDE (Inside)
2	26.419	65.430	CLOSING BAR GUIDE (Inside)
-----	-----	-----	-----
3	26.419	37.743	HANDLE 885 ESL2A-APHDSS @ 0.0°
4	2.000	2.118	GND STUD M6 x 16mm (Inside)
5	27.347	43.445	STUDS M6 x 18mm (Inside)
6	27.347	46.123	STUDS M6 x 18mm (Inside)

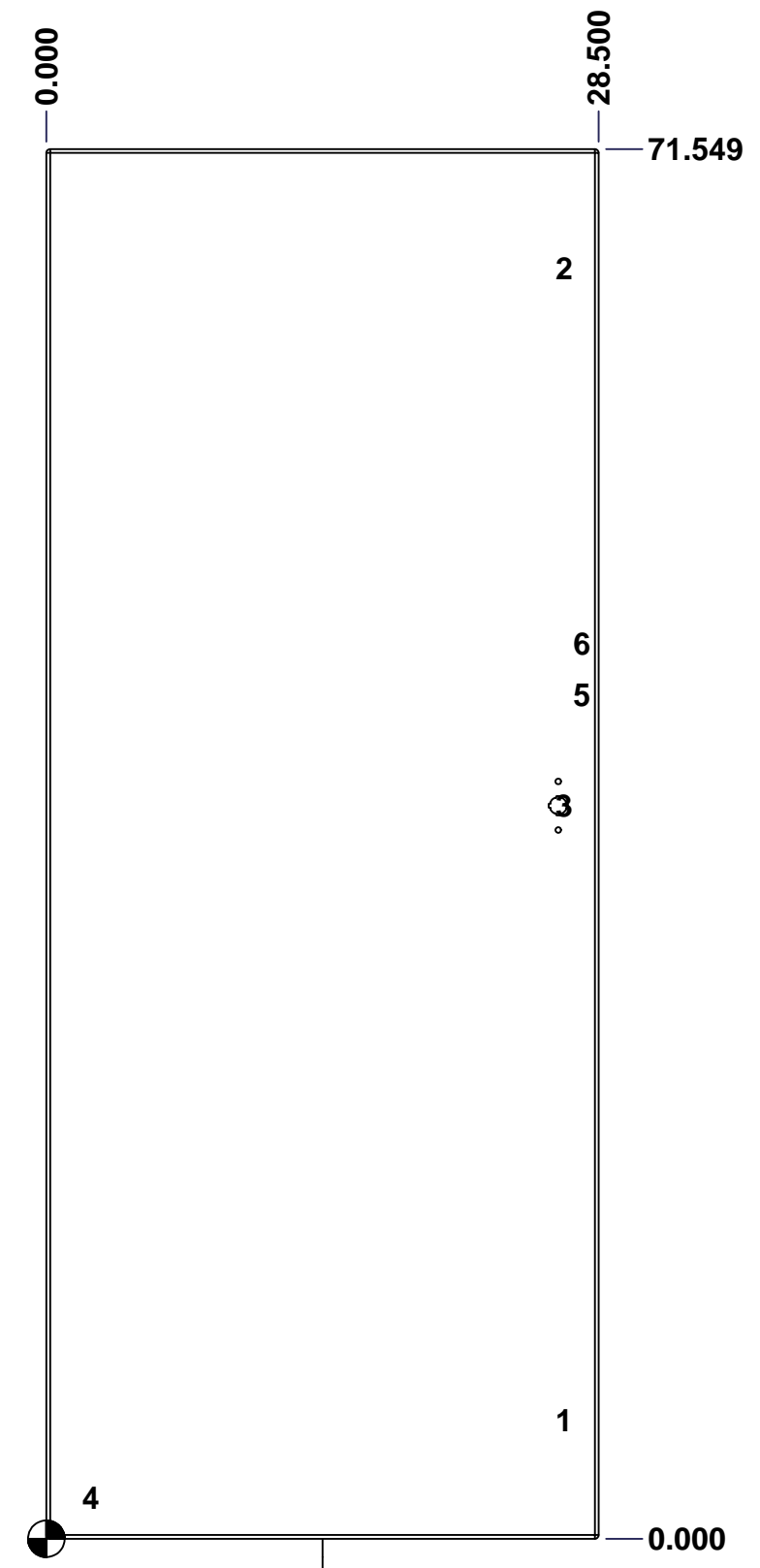

FRONT

	Description	Status
	5500UFDSS 72" x 61" Lock Door	(NULL)
	Part Number Numéro Pièce	Rev.
	5500UFDSS726112FD	0
		2
		3

This drawing is confidential and must not be reproduced or used without the consent of EXM

Ce dessin est confidentiel et ne doit pas être reproduit ou utilisé sans le consentement de EXM

No.	Revisions	Date	By/Par

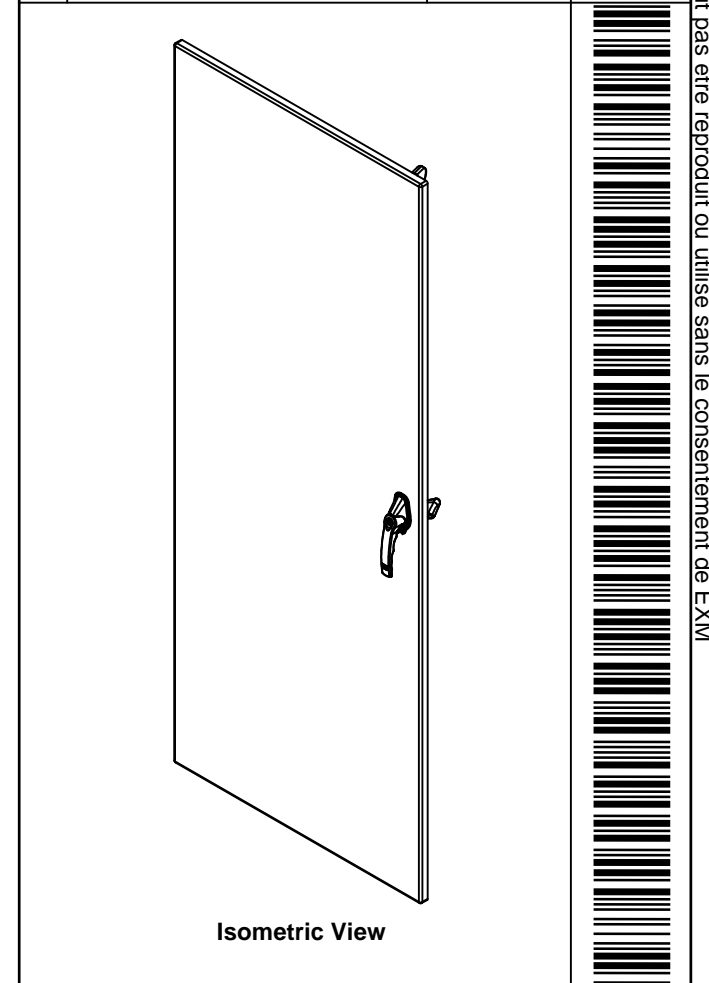

Qty	Part Name	Rev	Description
1	STK-Q-16085	0	Ground Stud M6 x 16mm Stainless Steel
1	5500UFDSS726112CB	0	5500UFDSS 72" Closing Bar
1	5500UFDSS726112CB2E SY	0	5500UFDSS 72" Disconnect Closing Bar
1	STK-A-03880-36	12	Gearbox Clockwise Assembly (Grip 36mm)
1	5500UFDSS726112FDG	0	5500UFDSS 72" x 61" Flange Door Gasket
1	885ESL-APHDSS	1	885 ESL2A-APHDSS - Stainless Steel L-Handle Padlockable Assy - Slot Cylinder
1	STK-P-02400S	0	Powder Paint (Asa-61 Grey / Smooth)
4	STK-Q-16070	1	Stud M6 x 18mm Stainless Steel
1	5500UFDSS726112FD-P	0	5500UFDSS 72" x 61" Lock Door Part
4	STK-K-09870	7	Cabinet Hinge with Captive Pins

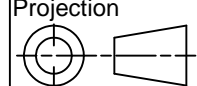
 Tél: (450) 979-4373 Fax: (450) 979-4626 www.exmweb.com		Flatness Aplatissement Max 3.0mm Projection 
Customer Client	Date	
Drawn By Dessiné Par: BoxCad: BoxCad	Date: 25-Mar-16	
Material Matière: 12 Ga Stainless Steel 304 (2.5mm)		
Color Couleur: Asa-61 Grey	Finish Fini: Smooth	
Description: 5500UFDSS 72" x 61" Lock Door		Detail Rev.
Part Number Numéro Pièce: 5500UFDSS726112FD	Rev. 0	3

Parts List

This drawing is confidential and must not be reproduced or used without the consent of EXM

Ce dessin est confidentiel et ne doit pas être reproduit ou utilisé sans le consentement de EXM

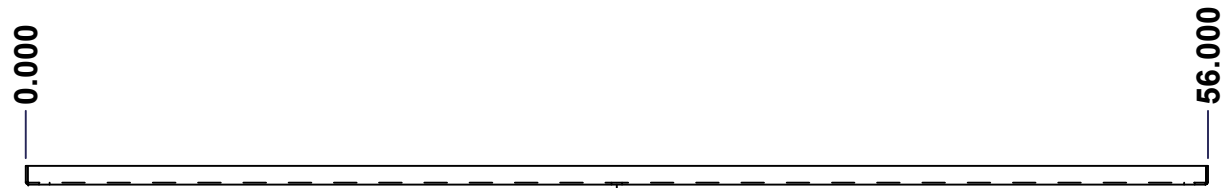

TOP

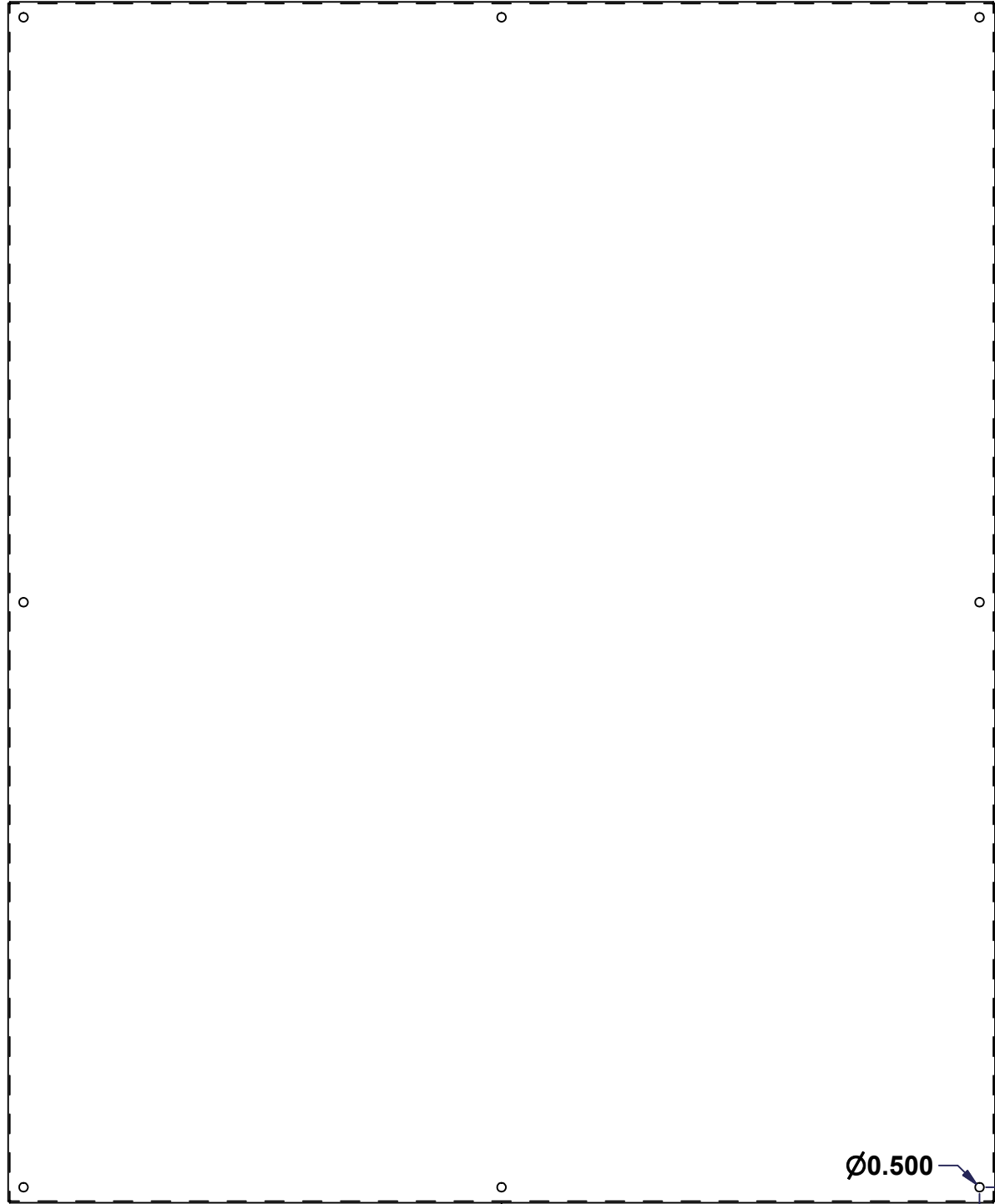

FRONT

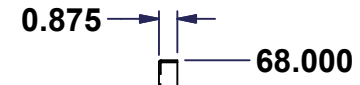

RIGHT

No.	Revisions	Date	By/Par

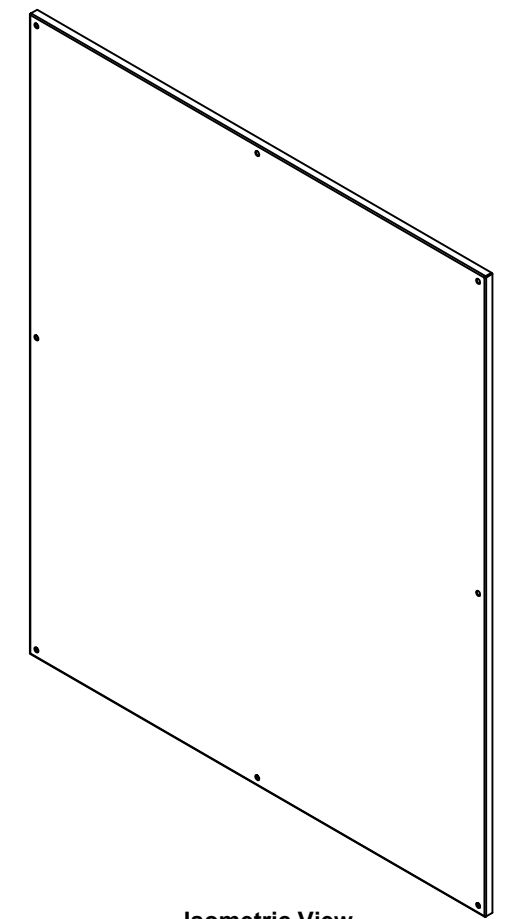

Isometric View



Tél: (450) 979-4373
 Fax: (450) 979-4626
 www.exmweb.com

Flatness
 Aplatissement
 Max 3.0mm
 Projection

Customer Client	Date
Drawn By / Dessiné Par: BoxCad	Date: 04/11/2009

Material / Matière: 12 Ga Galvanized (2.5mm)

Color / Couleur: Unpainted	Finish / Fini: Unpainted
----------------------------	--------------------------

Description: 885 SP7260G Inner Panel

Part Number / Numéro Pièce: 885SP7260G	Rev. 0	1 / 2
--	--------	-------

SEE BILL OF MATERIAL ON LAST PAGE

This drawing is confidential and must not be reproduced or used without the consent of EXM

Ce dessin est confidentiel et ne doit pas être reproduit ou utilisé sans le consentement de EXM

No.	Revisions	Date	By/Par

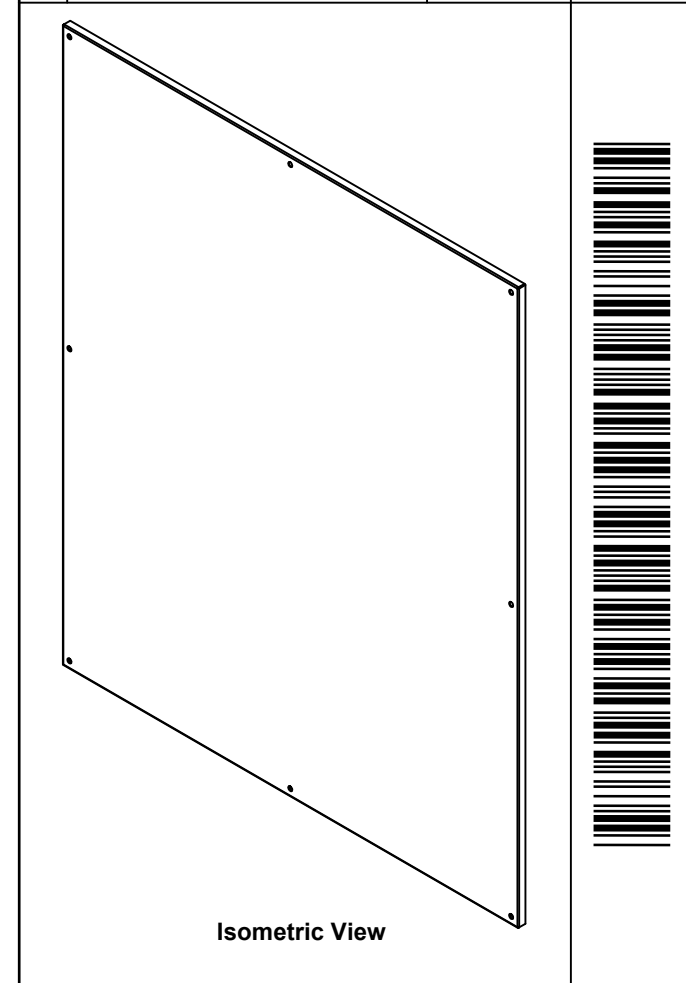

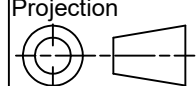
 Tél: (450) 979-4373 Fax: (450) 979-4626 www.exmweb.com		Flatness Aplatissement Max 3.0mm
Projection 		Date
Customer Client		Date 04/11/2009
Drawn By Dessiné Par BoxCad		Date
Material Matière 12 Ga Galvanized (2.5mm)		
Color Couleur Unpainted		Finish Fini Unpainted
Description 885 SP7260G Inner Panel		Detail Rev.
Part Number Numéro Pièce 885SP7260G		Rev. 2 0

Qty	Part Number	Rev	Description
1	885SP7260G-P	0	885 SP7260G Inner Panel Part
Parts List			