

This drawing is confidential and must not be reproduced or used without the consent of EXM

Ce dessin est confidentiel et ne doit pas être reproduit ou utilisé sans le consentement de EXM

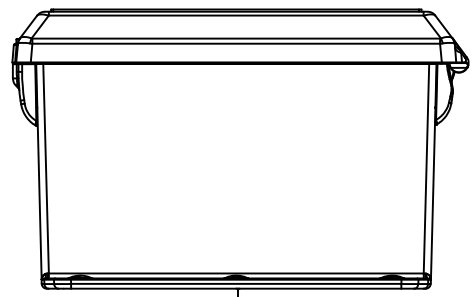

TOP

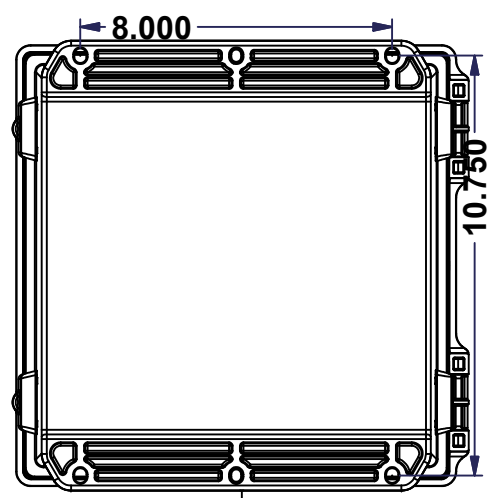

BACK

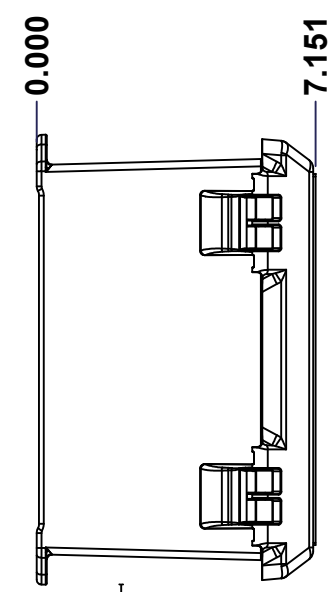

LEFT

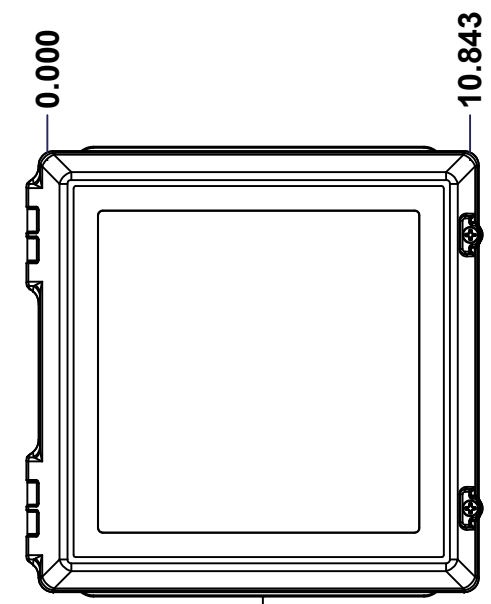

FRONT

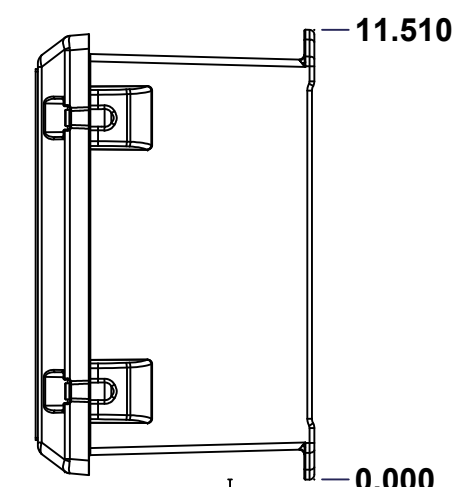

RIGHT

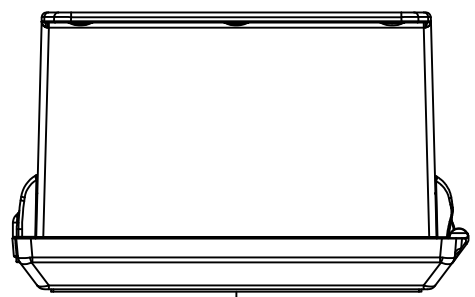

BOTTOM

No.	Revisions	Date	By/Par

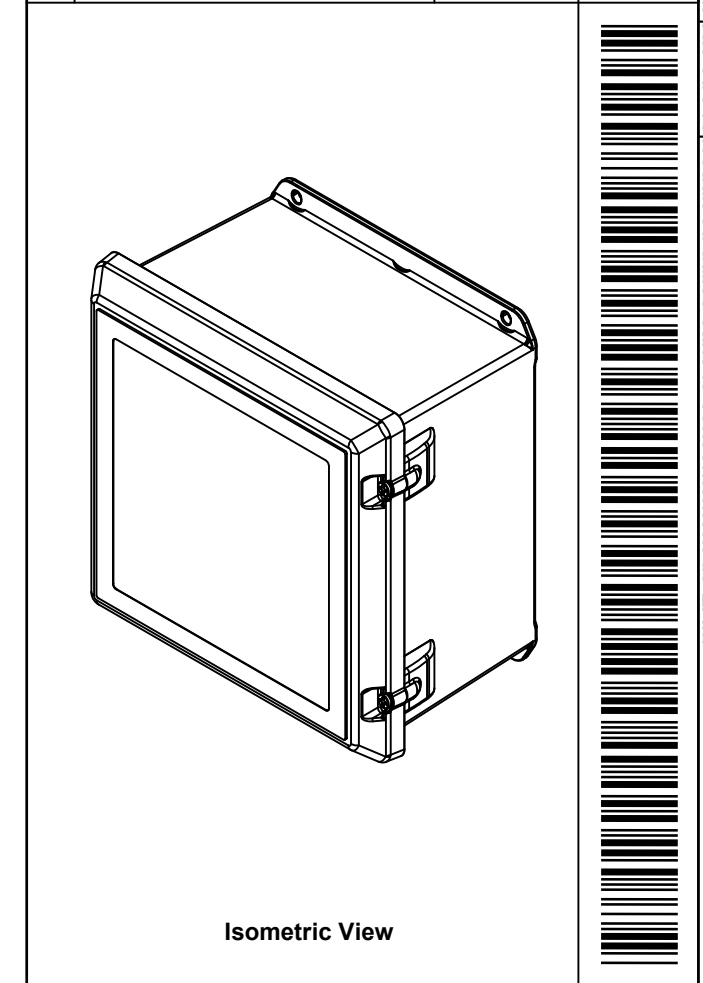

Isometric View



Tél: (450) 979-4373  
 Fax: (450) 979-4626  
[www.exmweb.com](http://www.exmweb.com)

Flatness  
Aplatissement  
Max 3.0mm  
Projection

Customer Client	Date
Drawn By Dessiné Par BoxCad: BoxCad	Date 23-Mar-21
Material Matière Polybutylene Terephthalate	
Color Couleur Light Grey RAL7035	Finish Fini MT-11020
Description 5600ESPLHW 10" x 10" x 6" Assembly	Detail Rev.
Part Number Numéro Pièce <b>5600ESPLHW101006</b>	Rev. 0

SEE BILL OF MATERIAL ON LAST PAGE

1
2

This drawing is confidential and must not be reproduced or used without the consent of EXM

Ce dessin est confidentiel et ne doit pas être reproduit ou utilisé sans le consentement de EXM

NOTE	
ITEM	DESCRIPTION
1	NEMA 6P Enclosure
2	C/W Standard inner panel (Included)

No.	Revisions	Date	By/Par

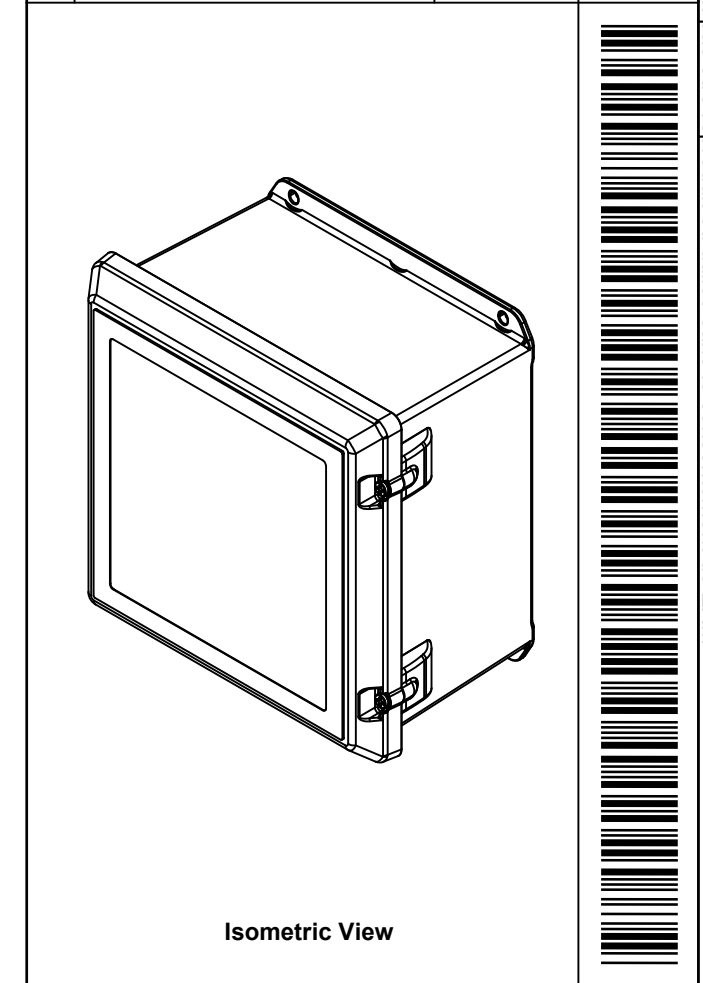

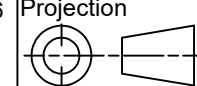
 Tél: (450) 979-4373 Fax: (450) 979-4626 <a href="http://www.exmweb.com">www.exmweb.com</a>		Flatness Aplatissement Max 3.0mm Projection 
Customer Client	Date	
Drawn By Dessiné Par	BoxCad: BoxCad	Date 23-Mar-21
Material Matière	Polybutylene Terephthalate	
Color Couleur	Light Grey RAL7035	Finish Fini MT-11020
Description	Detail Rev.	
5600ESPLHW 10" x 10" x 6" Assembly		
Part Number Numéro Pièce	Rev.	2
<b>5600ESPLHW101006</b>	<b>0</b>	<b>2</b>

PACKING		
ITEM	QTY	DESCRIPTION
Cardboard sleeve	2	Top and Bottom
Cardboard strip	2	Between back of enclosure and inner panel
Plastic bag	1	To protect cover surface and inside gasket
Packaging label	1	White label with product number

Qty	Part Number	Rev	Description
4	STK-Q-05035	4	M4.8 x 10mm Truss Head Square Tapping Screw
1	880 SP1010G	0	880 SP1010G - Inner Panel
1	5600ESPLHW101006C	0	5600ESPLHW 10" x 10" Cover
1	5600ESPLHW101006B	0	5600ESPLHW 10" x 10" x 6" Body
Parts List			

This drawing is confidential and must not be reproduced or used without the consent of EXM

Ce dessin est confidentiel et ne doit pas être reproduit ou utilisé sans le consentement de EXM

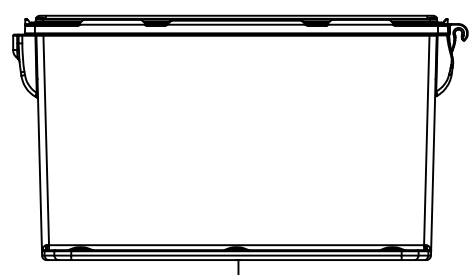

TOP

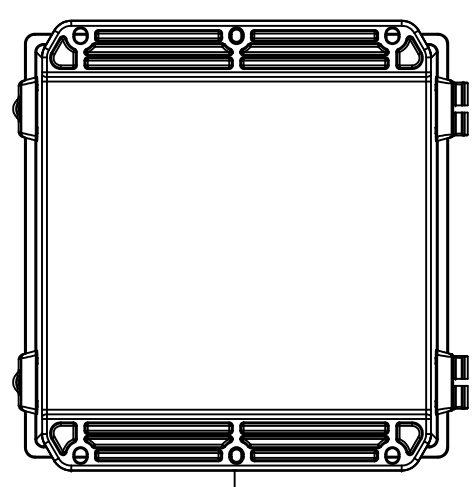

BACK

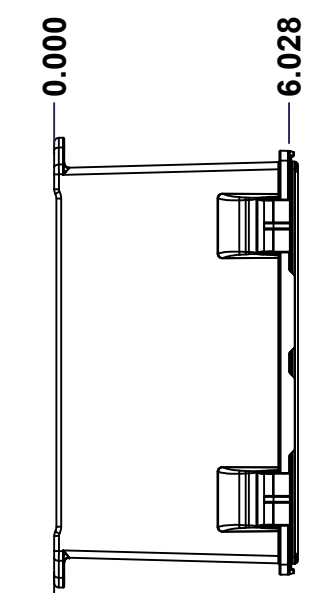

LEFT

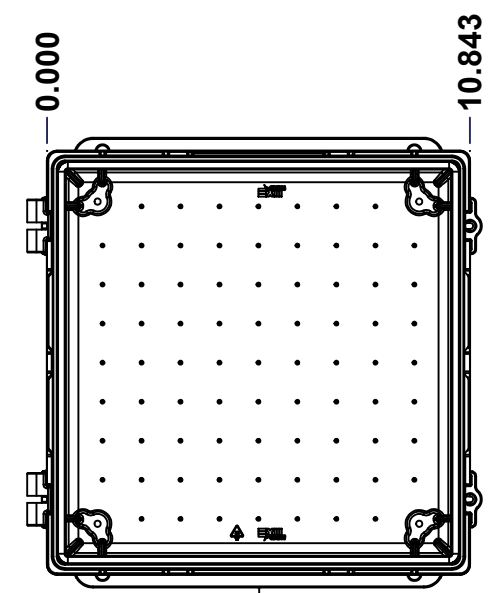

FRONT

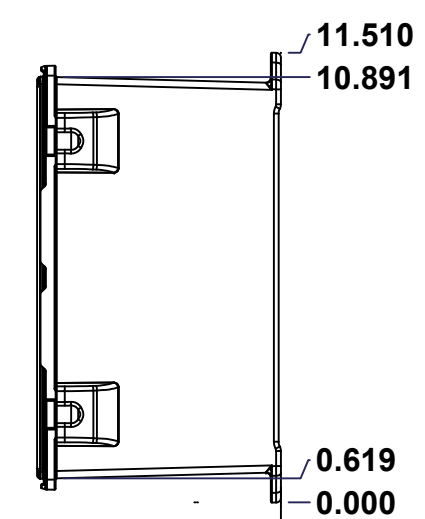

RIGHT

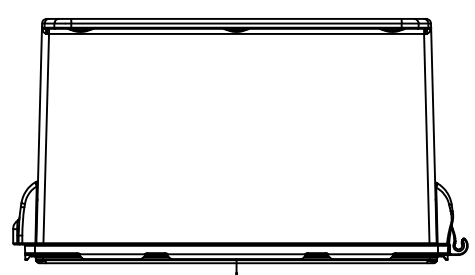

BOTTOM

No.	Revisions	Date	By/Par

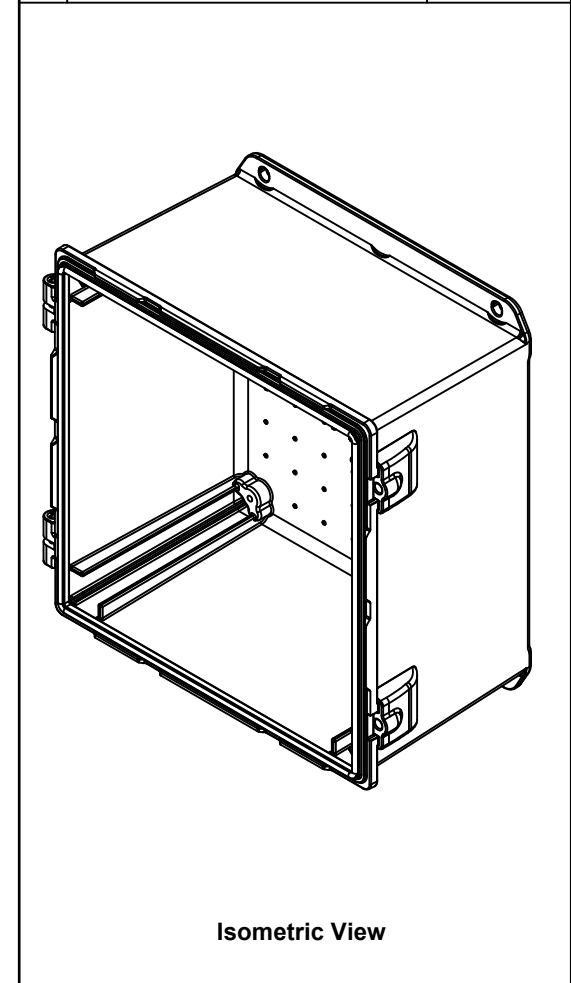

Isometric View

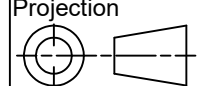

 Tél: (450) 979-4373 Fax: (450) 979-4626 <a href="http://www.exmweb.com">www.exmweb.com</a>		Flatness Aplatissement Max 3.0mm Projection 
Customer Client	Date	
Drawn By Dessiné Par	BoxCad: BoxCad	Date 23-Mar-21
Material Matière	Polybutylene Terephthalate	
Color Couleur	Light Grey RAL7035	Finish Fini MT-11020
Description 5600ESPLHW 10" x 10" x 6" Body		Detail Rev.
Part Number Numéro Pièce	Rev. 0	1 / 7

SEE BILL OF MATERIAL ON LAST PAGE

**5600ESPLHW101006B**

This drawing is confidential and must not be reproduced or used without the consent of EXM

Ce dessin est confidentiel et ne doit pas être reproduit ou utilisé sans le consentement de EXM

No.	Revisions	Date	By/Par

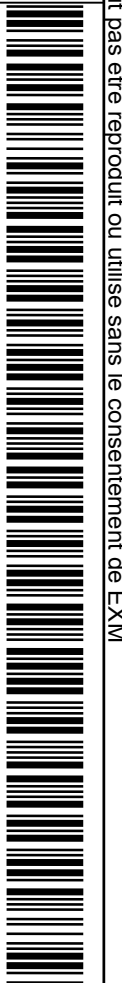
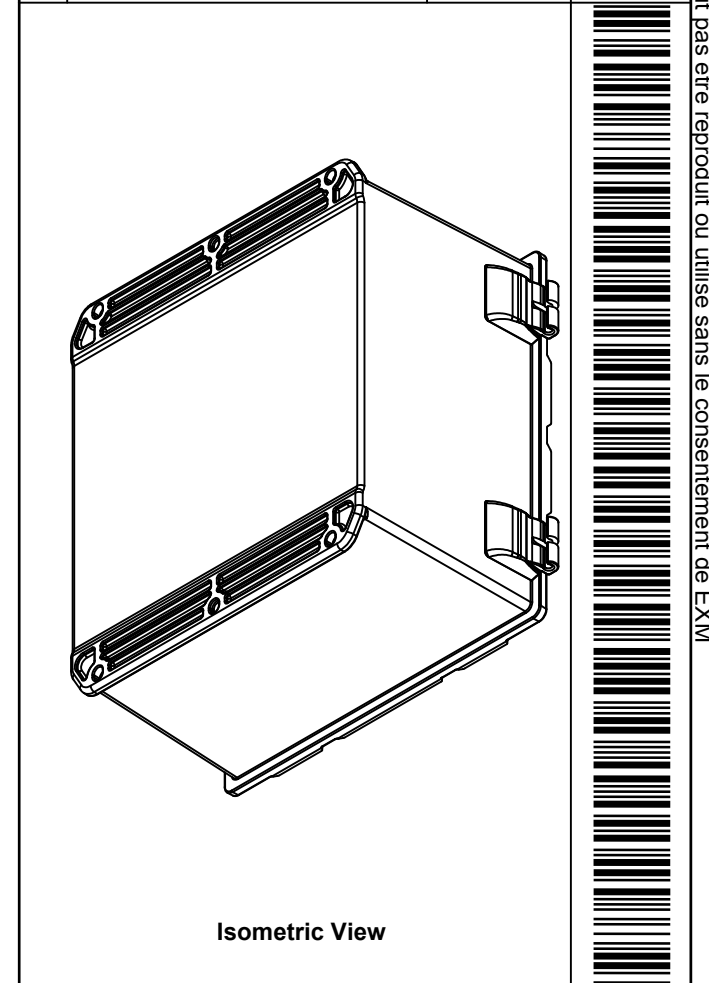

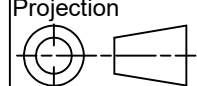
 Tél: (450) 979-4373 Fax: (450) 979-4626 <a href="http://www.exmweb.com">www.exmweb.com</a>		Flatness Aplatissement Max 3.0mm Projection 
Customer Client	Date	
Drawn By Dessiné Par	BoxCad: BoxCad	Date 23-Mar-21
Material Matière	Polybutylene Terephthalate	
Color Couleur	Light Grey RAL7035	Finish Fini MT-11020
Description		Detail Rev.
5600ESPLHW 10" x 10" x 6" Body		
Part Number Numéro Pièce	Rev.	7
<b>5600ESPLHW101006B</b>	<b>0</b>	7

Qty	Part Number	Rev	Description
2	STK-Q-70491	1	5600 ESPL Cover Screw Bracket
1	5600ESPLHW101006G	8	5600 ESPL Base Gasket
2	STK-Q-33920	3	5600 ESPL Cover Hinge Bracket
1	5600ESPLHW101006B-P	0	5600ESPLHW 10" x 10" x 6" Body Part
Parts List			

This drawing is confidential and must not be reproduced or used without the consent of EXM

Ce dessin est confidentiel et ne doit pas être reproduit ou utilisé sans le consentement de EXM

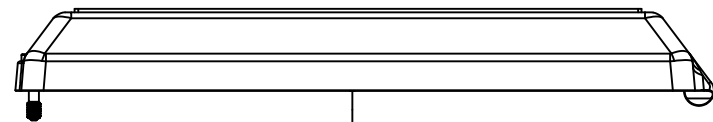

TOP

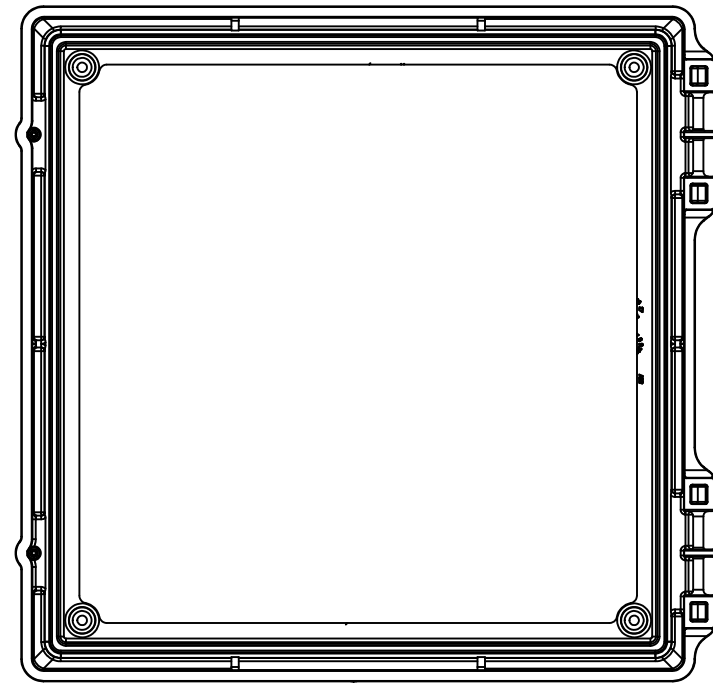

BACK

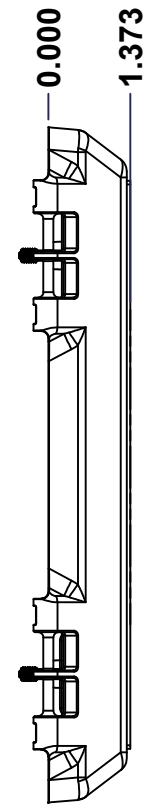

LEFT

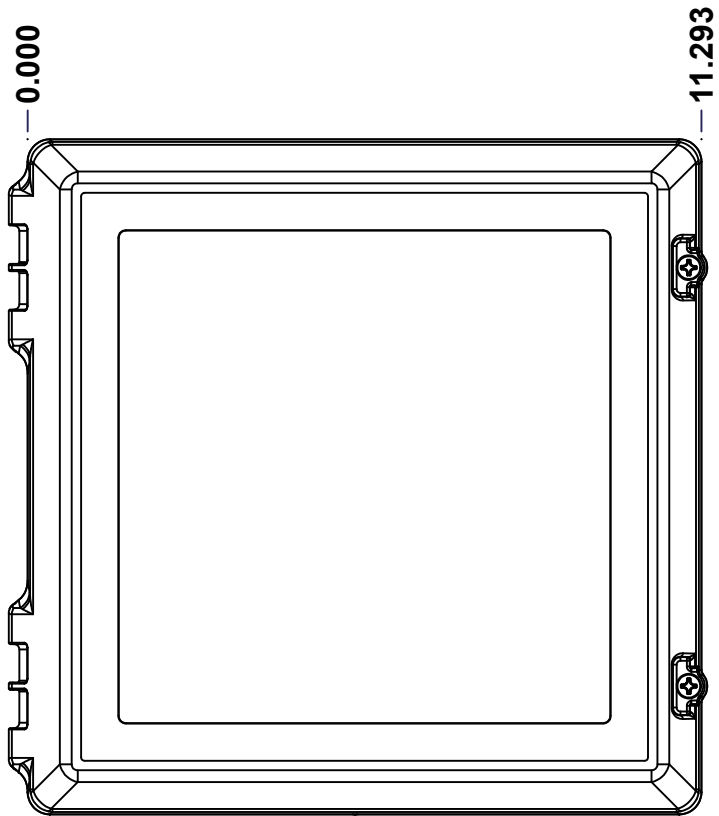

FRONT

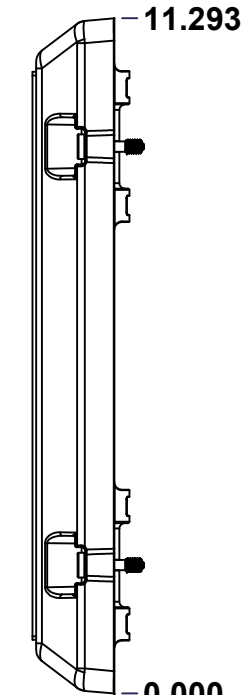

RIGHT

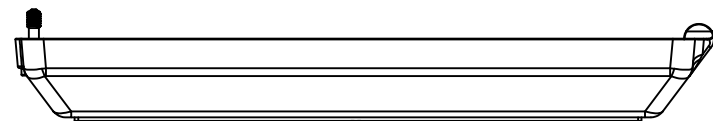

BOTTOM

No.	Revisions	Date	By/Par

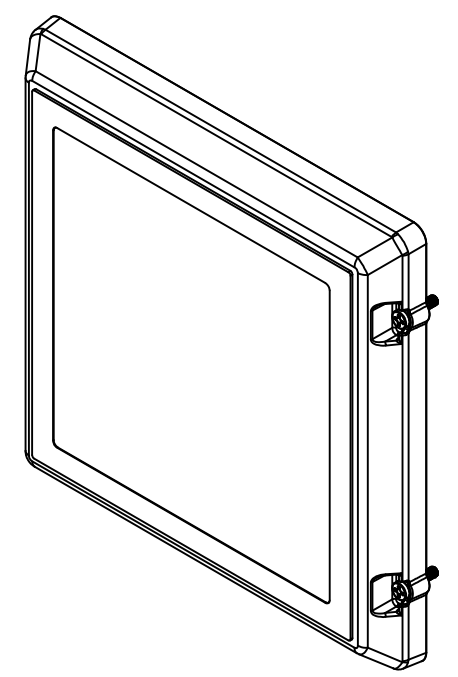

Isometric View



Tél: (450) 979-4373 Fax: (450) 979-4626 <a href="http://www.exmweb.com">www.exmweb.com</a>		Flatness Aplatissement Max 3.0mm Projection 
Customer Client	Date	
Drawn By Dessiné Par	BoxCad: BoxCad	Date 23-Mar-21
Material Matière	Polybutylene Terephthalate	
Color Couleur	Light Grey RAL7035	Finish Fini MT-11020
Description 5600ESPLHW 10" x 10" Cover		Detail Rev.
Part Number Numéro Pièce	Rev. 0	1 / 3

SEE BILL OF MATERIAL ON LAST PAGE **5600ESPLHW101006C**

This drawing is confidential and must not be reproduced or used without the consent of EXM

Ce dessin est confidentiel et ne doit pas être reproduit ou utilisé sans le consentement de EXM

No.	Revisions	Date	By/Par

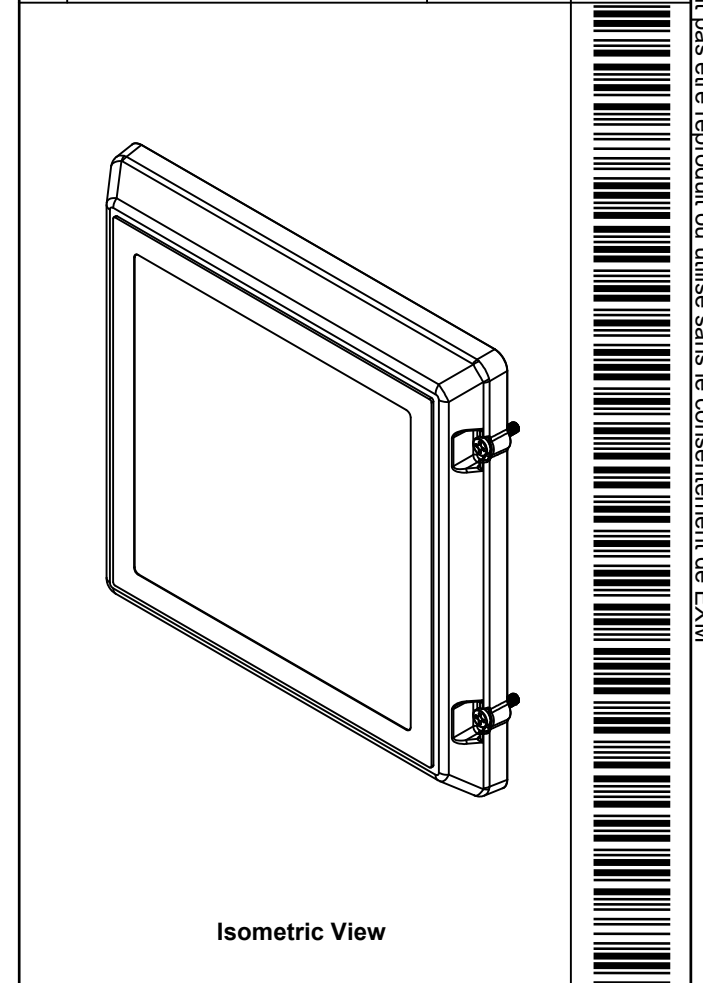

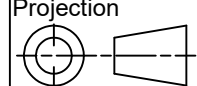
 Tél: (450) 979-4373 Fax: (450) 979-4626 <a href="http://www.exmweb.com">www.exmweb.com</a>		Flatness Aplatissement Max 3.0mm Projection 
Customer Client	Date	
Drawn By Dessiné Par	BoxCad: BoxCad	Date 23-Mar-21
Material Matière	Polybutylene Terephthalate	
Color Couleur	Light Grey RAL7035	Finish Fini MT-11020
Description		Detail Rev.
5600ESPLHW 10" x 10" Cover		
Part Number Numéro Pièce	Rev.	3
<b>5600ESPLHW101006C</b>	<b>0</b>	<b>3</b>

Qty	Part Name	Rev	Description
1	5600ESPLHW101006LX	0	5600ESPLHW 9.341" x 9.341" Lexan Part
2	STK-Q-03520	2	M6 x 25mm Phillips Screw
1	5600ESPLHW101006C-P	0	5600ESPLHW 10" x 10" x 6" Cover Part
Parts List			

This drawing is confidential and must not be reproduced or used without the consent of EXM

Ce dessin est confidentiel et ne doit pas être reproduit ou utilisé sans le consentement de EXM

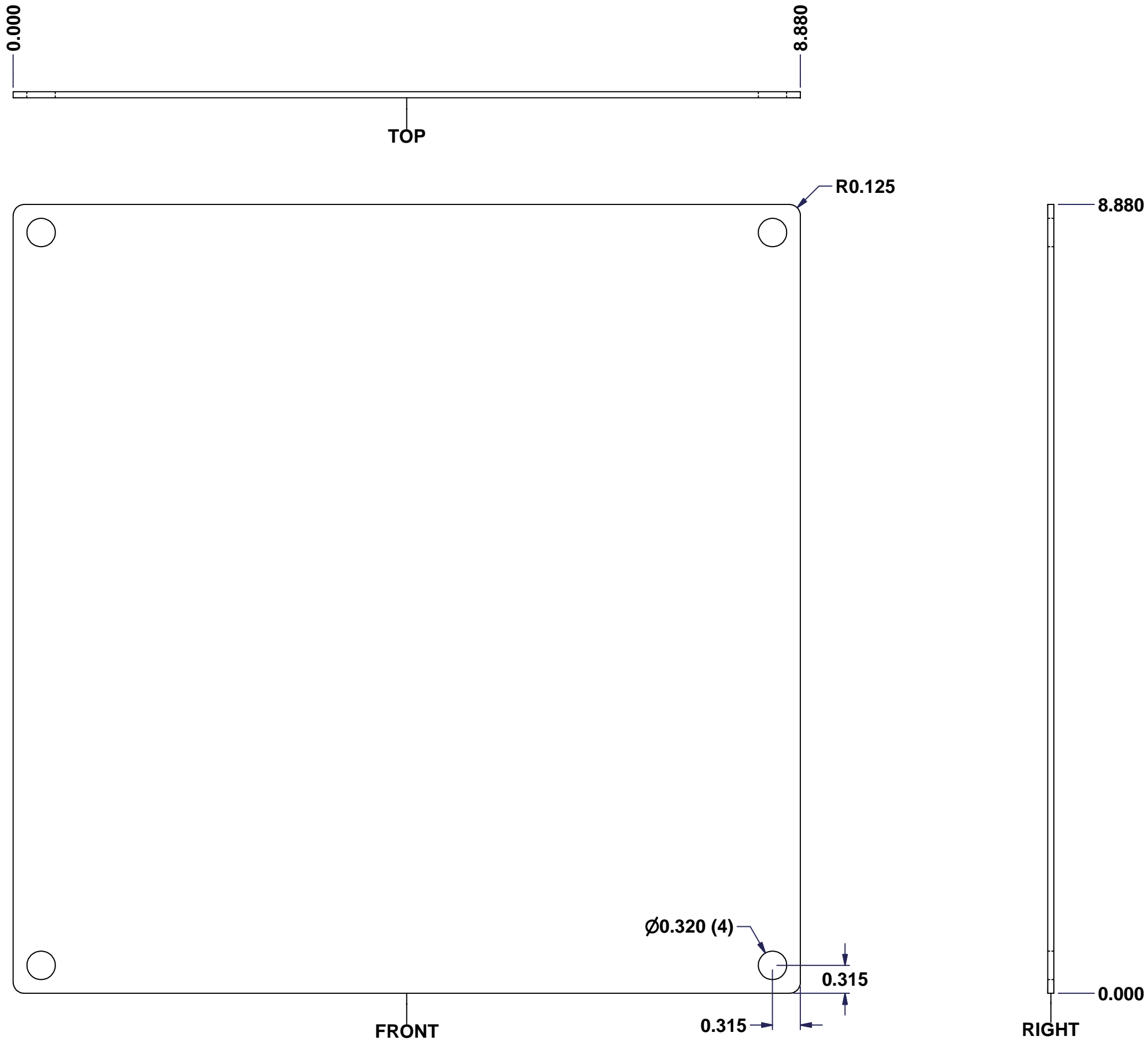

No.	Revisions	Date	By/Par

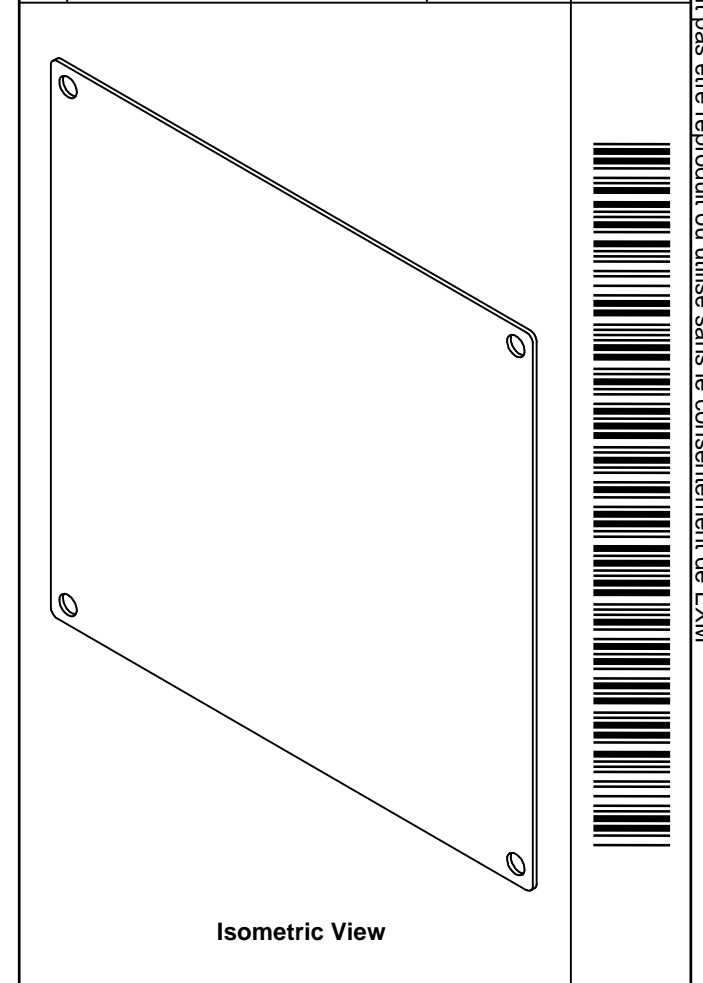

Tél: (450) 979-4373 Fax: (450) 979-4626 www.exmweb.com	Flatness Aplatissement Max 3.0mm
	Projection 
Customer Client	Date
Drawn By / Dessiné Par: BoxCad	Date: 23-Jan-07
Material / Matière: 14 Ga Galvanized (1.7mm)	
Color / Couleur: Unpainted	Finish / Fini: Galvanized
Description: 880 SP1010G - Inner Panel	
Detail Rev.	
Part Number / Numéro Pièce: <b>880 SP1010G</b>	Rev. 1 / 2

SEE BILL OF MATERIAL ON LAST PAGE

This drawing is confidential and must not be reproduced or used without the consent of EXM

Ce dessin est confidentiel et ne doit pas être reproduit ou utilisé sans le consentement de EXM

No.	Revisions	Date	By/Par

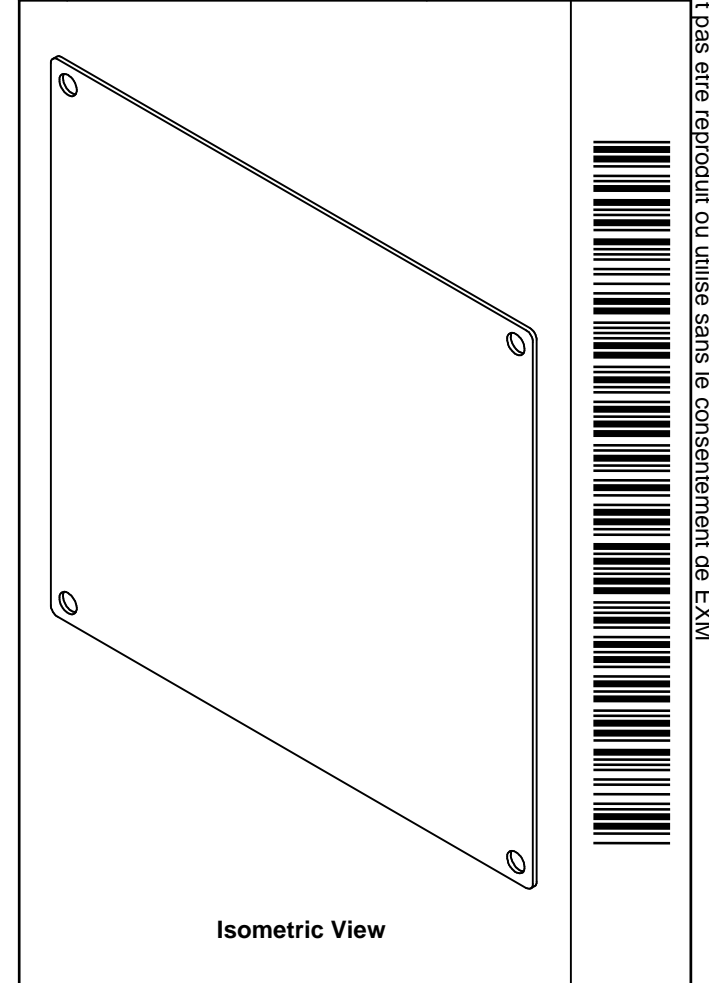

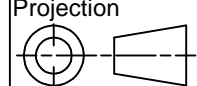
 Tél: (450) 979-4373 Fax: (450) 979-4626 www.exmweb.com		Flatness Aplatissement Max 3.0mm
Customer Client		Projection 
Drawn By Dessiné Par BoxCad		Date 23-Jan-07
Material Matière 14 Ga Galvanized (1.7mm)		
Color Couleur Unpainted	Finish Fini Galvanized	
Description 880 SP1010G - Inner Panel		Detail Rev.
Part Number Numéro Pièce <b>880 SP1010G</b>		Rev. <b>0</b>

Qty	Part Number	Rev	Description
1	880 SP1010G-P	0	880 SP1010G - Inner Panel Part
Parts List			

2
2