

This drawing is confidential and must not be reproduced or used without the consent of EXM

Ce dessin est confidentiel et ne doit pas être reproduit ou utilisé sans le consentement de EXM

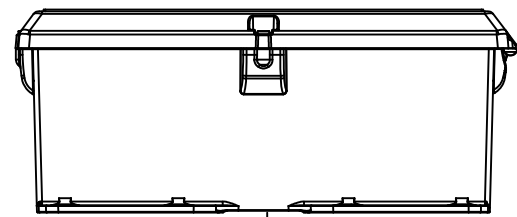

TOP

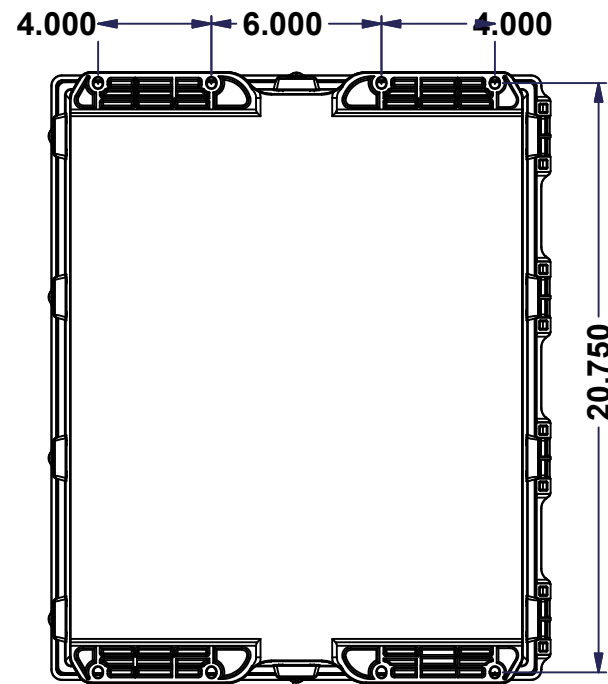

BACK

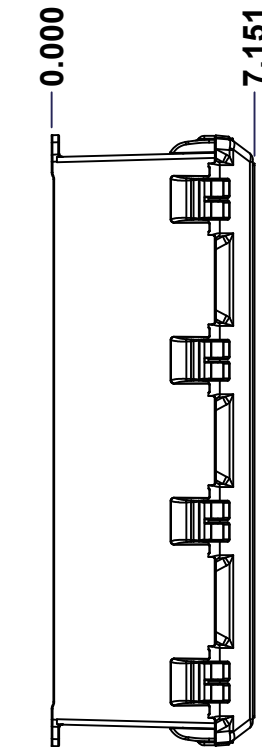

LEFT

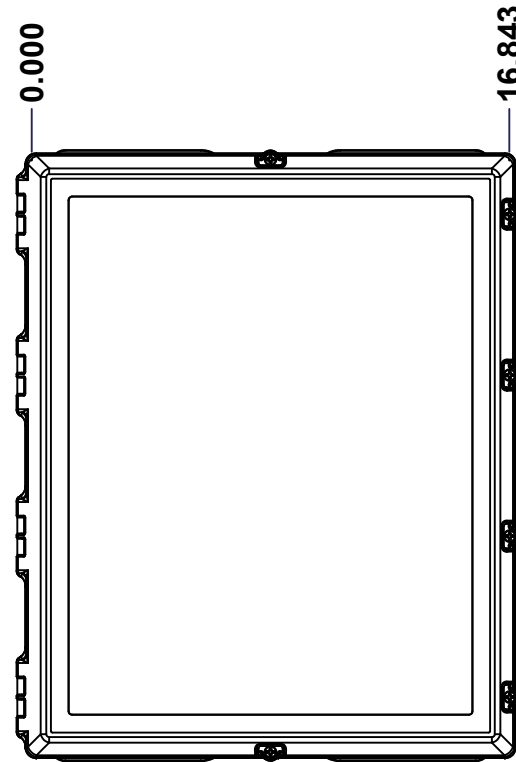

FRONT

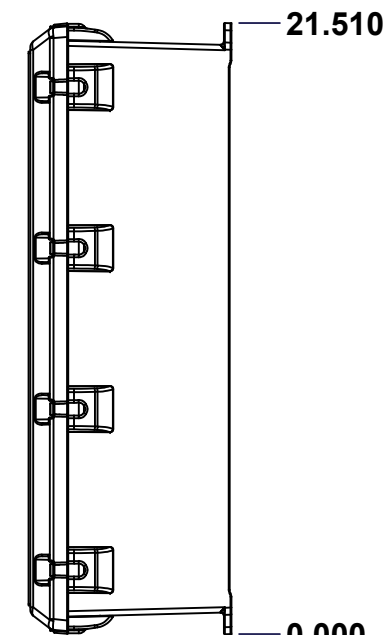

RIGHT

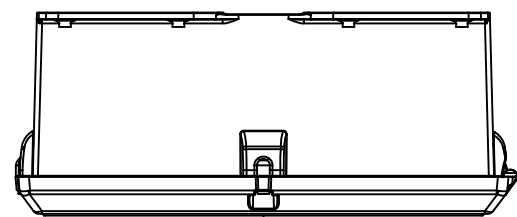

BOTTOM

No.	Revisions	Date	By/Par

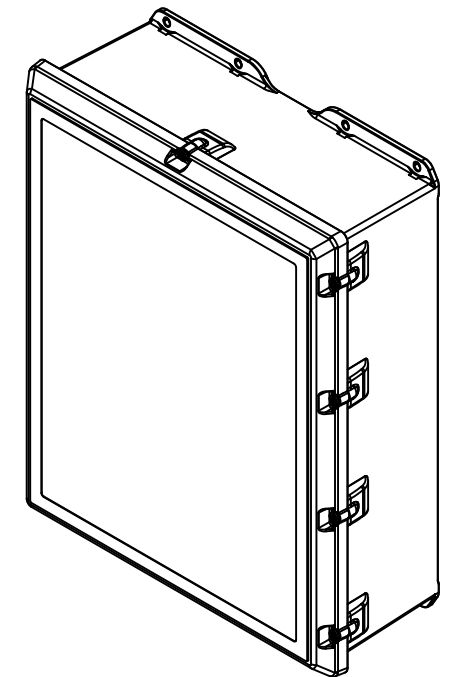

Isometric View



Tél: (450) 979-4373
 Fax: (450) 979-4626
www.exmweb.com

Flatness
Aplatissement
Max 3.0mm
Projection

Customer Client
 Drawn By Dessiné Par BoxCad: BoxCad
 Date 23-Mar-21

Material Matière Polybutylene Terephthalate

Color Couleur Light Grey RAL7035
 Finish Fini MT-11020

Description 5600ESPLHW 20" x 16" x 6" Assembly
 Detail Rev.

Part Number Numéro Pièce 5600ESPLHW201606
 Rev. 0

SEE BILL OF MATERIAL ON LAST PAGE

This drawing is confidential and must not be reproduced or used without the consent of EXM

Ce dessin est confidentiel et ne doit pas être reproduit ou utilisé sans le consentement de EXM

NOTE	
ITEM	DESCRIPTION
1	NEMA 6P Enclosure
2	C/W Standard inner panel (Included)

No.	Revisions	Date	By/Par

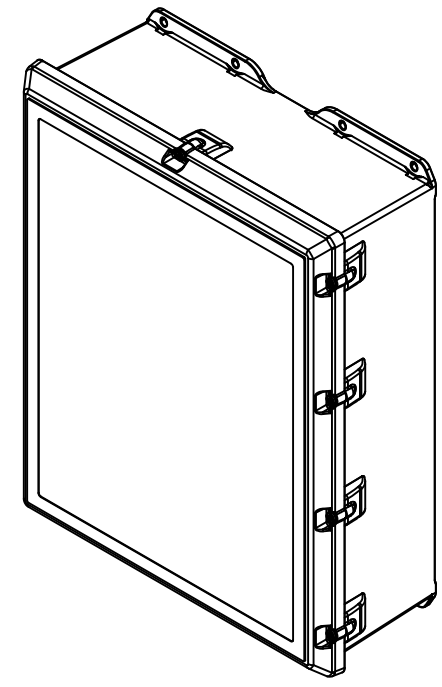

Isometric View

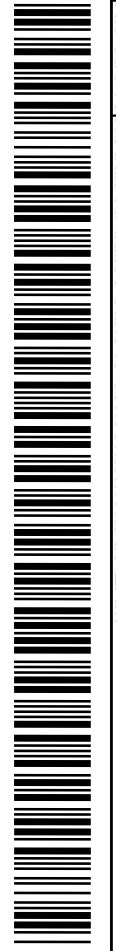

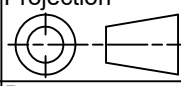
 Tél: (450) 979-4373 Fax: (450) 979-4626 www.exmweb.com	Flatness Aplatissement Max 3.0mm
	Projection 
Customer Client	Date
Drawn By Dessiné Par BoxCad: BoxCad	Date 23-Mar-21
Material Matière Polybutylene Terephthalate	
Color Couleur Light Grey RAL7035	Finish Fini MT-11020
Description 5600ESPLHW 20" x 16" x 6" Assembly	
Part Number Numéro Pièce 5600ESPLHW201606	Rev. 2 0

PACKING		
ITEM	QTY	DESCRIPTION
Cardboard sleeve	2	Top and Bottom
Cardboard strip	2	Between back of enclosure and inner panel
Plastic bag	1	To protect cover surface and inside gasket
Packaging label	1	White label with product number

Qty	Part Number	Rev	Description
4	STK-Q-05035	4	M4.8 x 10mm Truss Head Square Tapping Screw
1	880 SP2016G	0	880 SP2016G - Inner Panel
1	5600ESPLHW201606C	0	5600ESPLHW 20" x 16" Cover
1	5600ESPLHW201606B	0	5600ESPLHW 20" x 16" x 6" Body
Parts List			

This drawing is confidential and must not be reproduced or used without the consent of EXM

Ce dessin est confidentiel et ne doit pas être reproduit ou utilisé sans le consentement de EXM

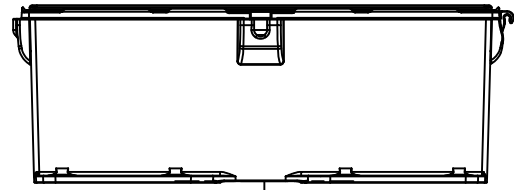

TOP

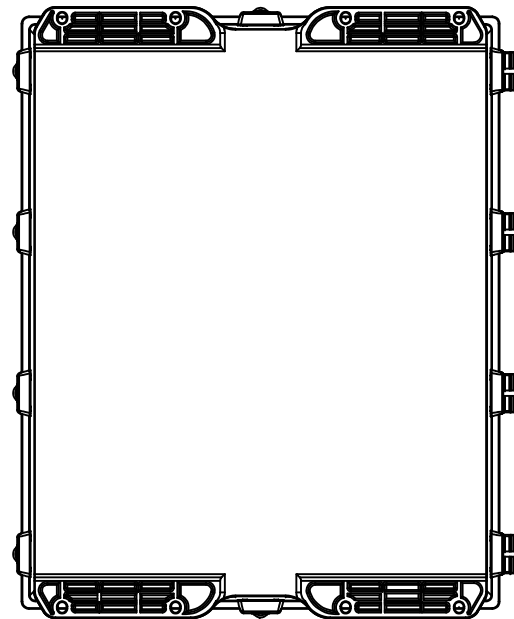

BACK

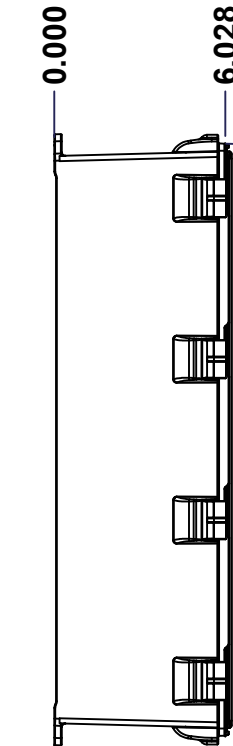

LEFT

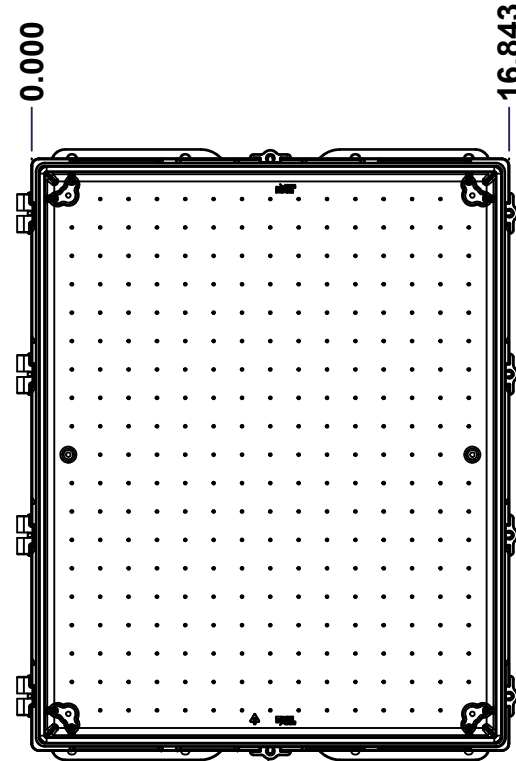

FRONT

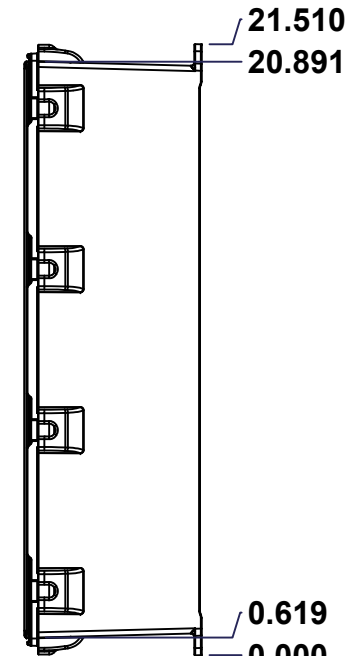

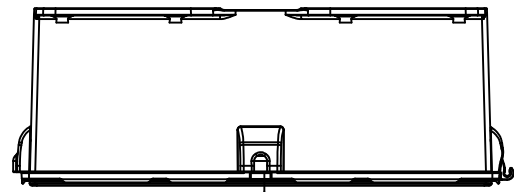

RIGHT

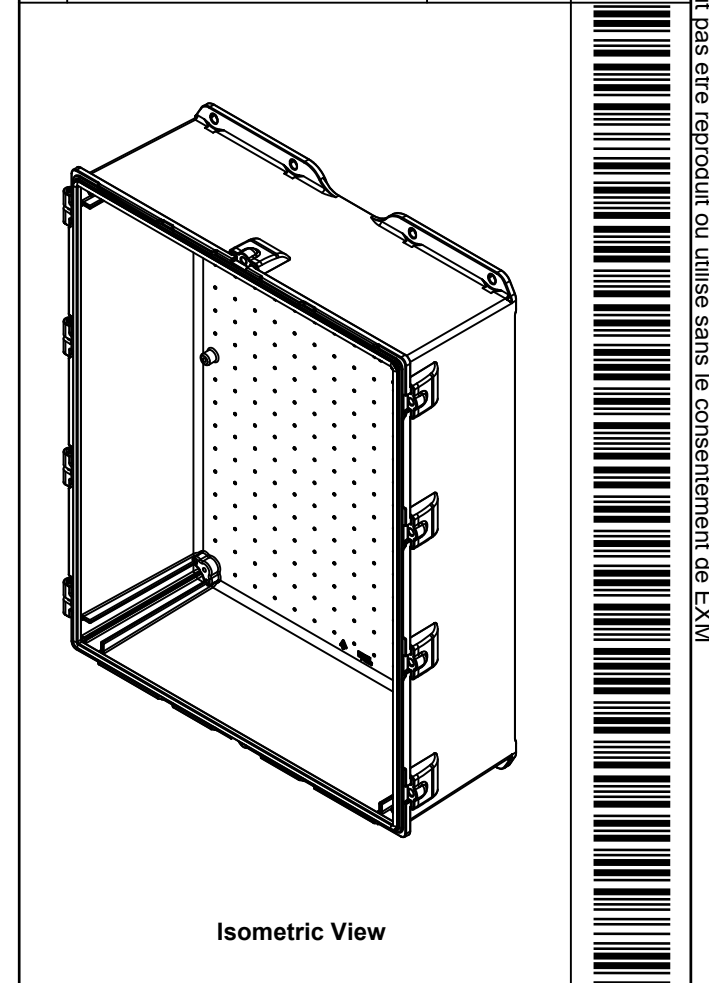

BOTTOM

No.	Revisions	Date	By/Par

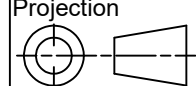

 Tél: (450) 979-4373 Fax: (450) 979-4626 www.exmweb.com		Flatness Aplatissement Max 3.0mm	
		Projection 	
Customer Client		Date	
Drawn By Dessiné Par BoxCad: BoxCad		Date 23-Mar-21	
Material Matière		Polybutylene Terephthalate	
Color Couleur	Light Grey RAL7035	Finish Fini	MT-11020
Description		Detail Rev.	
5600ESPLHW 20" x 16" x 6" Body			
Part Number Numéro Pièce		Rev.	1
5600ESPLHW201606B		0	7

SEE BILL OF MATERIAL ON LAST PAGE

This drawing is confidential and must not be reproduced or used without the consent of EXM

Ce dessin est confidentiel et ne doit pas être reproduit ou utilisé sans le consentement de EXM

No.	Revisions	Date	By/Par

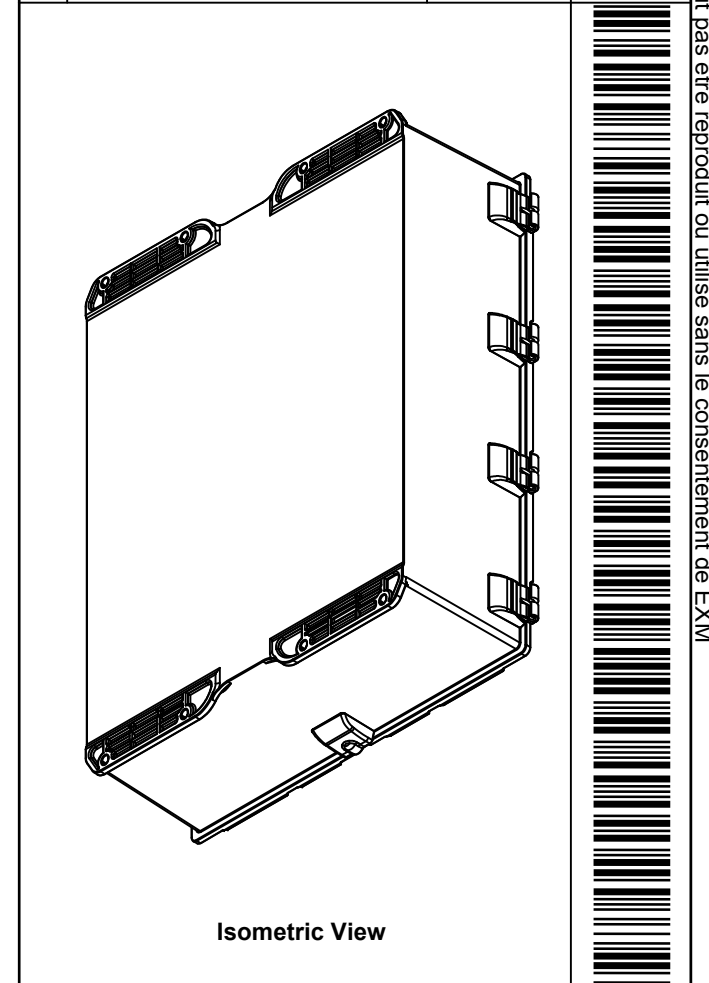

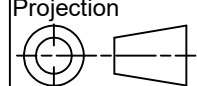
 Tél: (450) 979-4373 Fax: (450) 979-4626 www.exmweb.com		Flatness Aplatissement Max 3.0mm Projection 
Customer Client	Date	
Drawn By Dessiné Par	BoxCad: BoxCad	Date 23-Mar-21
Material Matière	Polybutylene Terephthalate	
Color Couleur	Light Grey RAL7035	Finish Fini MT-11020
Description		Detail Rev.
5600ESPLHW 20" x 16" x 6" Body		
Part Number Numéro Pièce	Rev.	7
5600ESPLHW201606B	0	7

Qty	Part Number	Rev	Description
6	STK-Q-70491	1	5600 ESPL Cover Screw Bracket
4	STK-Q-33920	3	5600 ESPL Cover Hinge Bracket
1	5600ESPLHW201606G	8	5600 ESPL Base Gasket
1	5600ESPLHW201606B-P	0	5600ESPLHW 20" x 16" x 6" Body Part
Parts List			

This drawing is confidential and must not be reproduced or used without the consent of EXM

Ce dessin est confidentiel et ne doit pas être reproduit ou utilisé sans le consentement de EXM

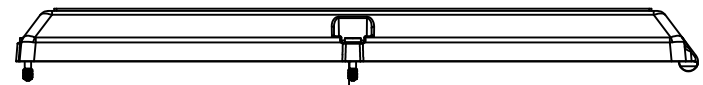

TOP

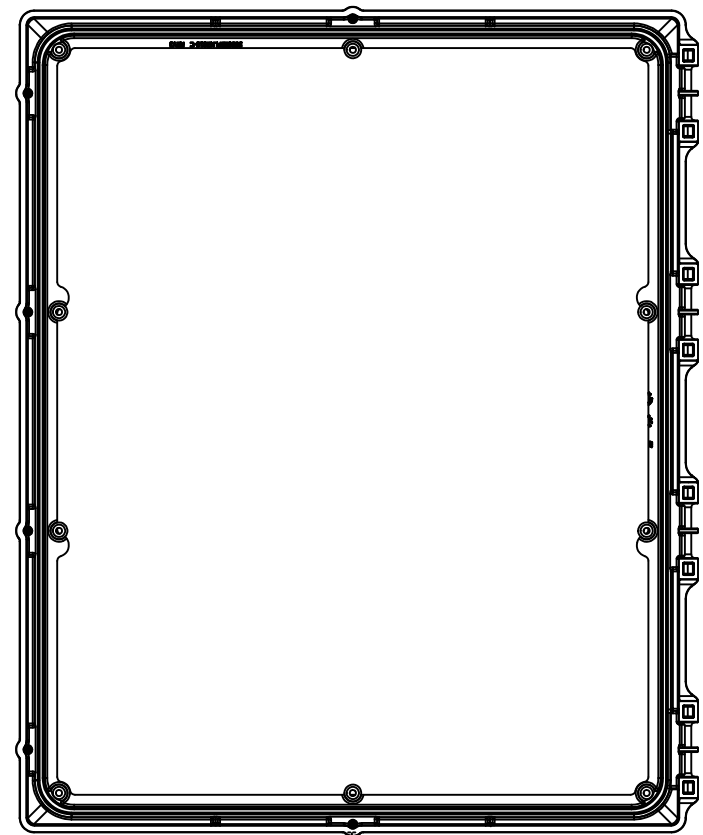

BACK

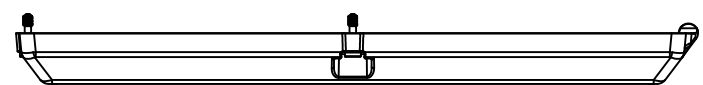

BOTTOM

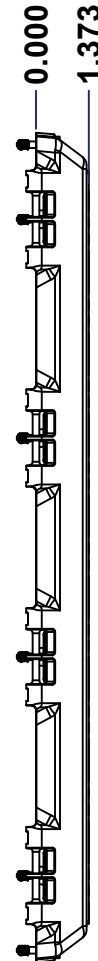

LEFT

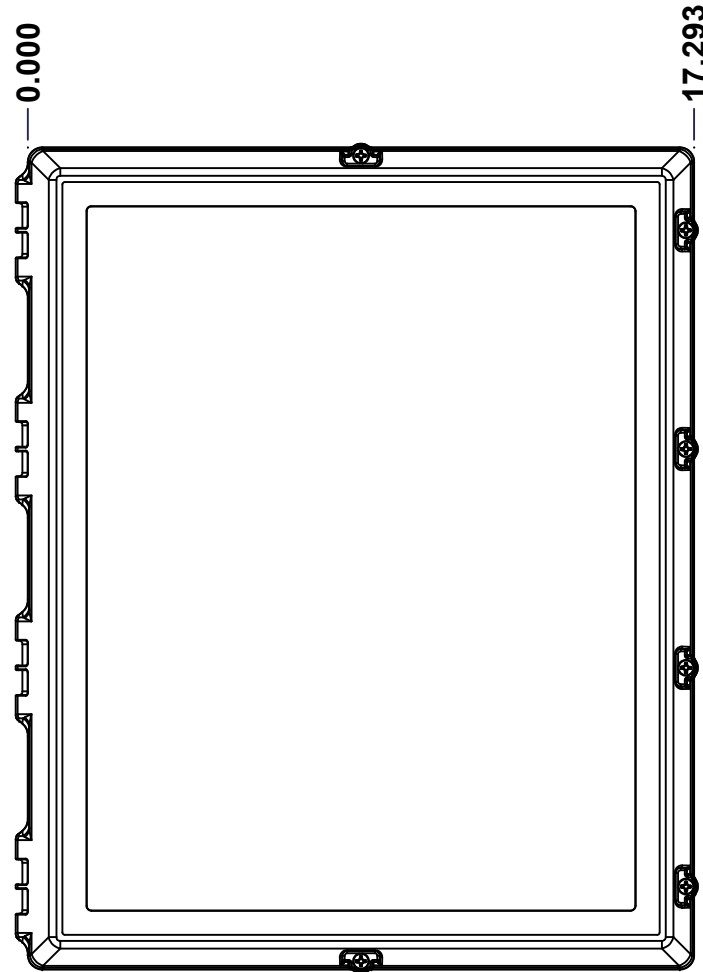

FRONT

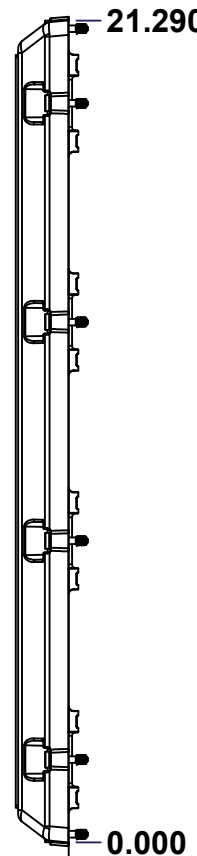

RIGHT

No.	Revisions	Date	By/Par

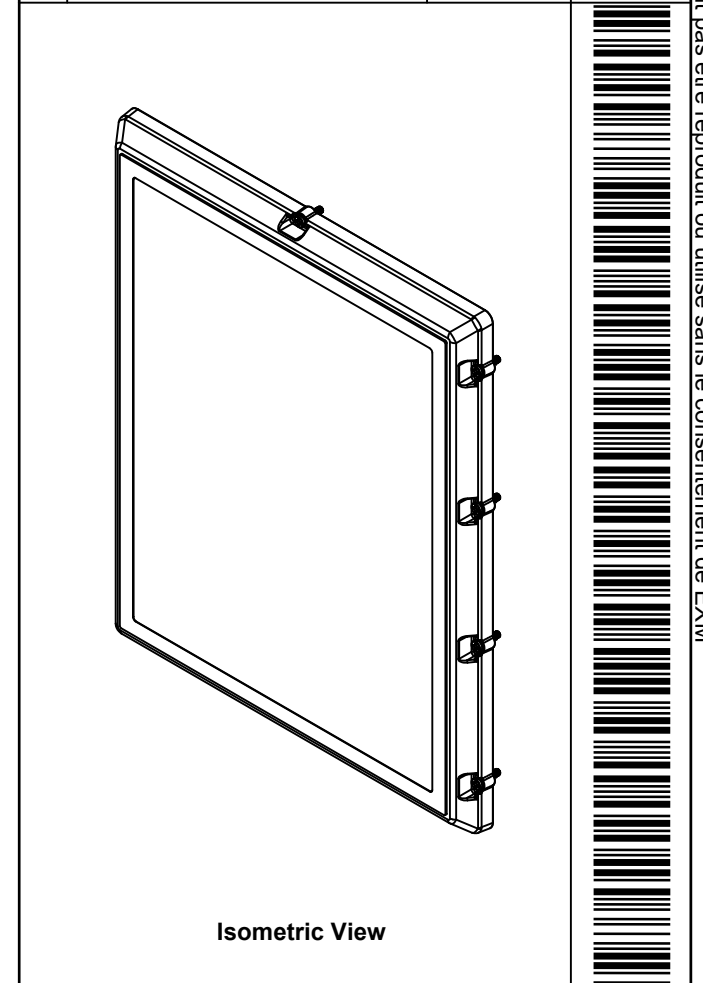

Isometric View

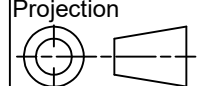

 Tél: (450) 979-4373 Fax: (450) 979-4626 www.exmweb.com		Flatness Aplatissement Max 3.0mm Projection 
Customer Client	Date	
Drawn By Dessiné Par	BoxCad: BoxCad	Date 23-Mar-21
Material Matière	Polybutylene Terephthalate	
Color Couleur	Light Grey RAL7035	Finish Fini MT-11020
Description	Detail Rev.	
5600ESPLHW 20" x 16" Cover		
Part Number Numéro Pièce	Rev. 0	1 / 3
5600ESPLHW201606C		

SEE BILL OF MATERIAL ON LAST PAGE

This drawing is confidential and must not be reproduced or used without the consent of EXM

Ce dessin est confidentiel et ne doit pas être reproduit ou utilisé sans le consentement de EXM

No.	Revisions	Date	By/Par

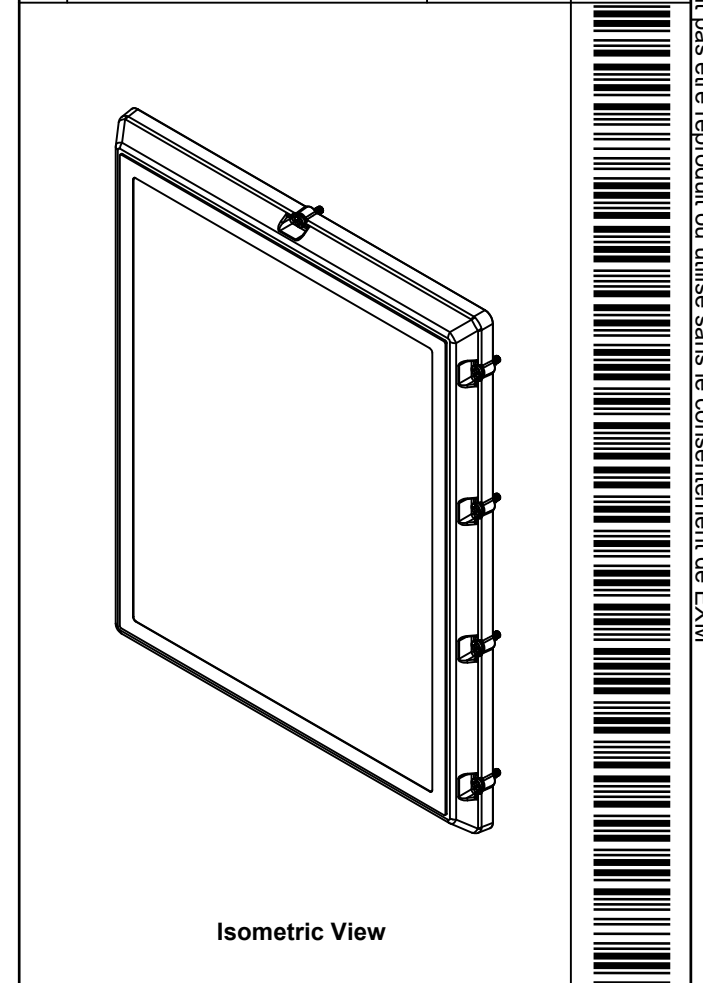

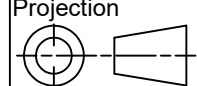
 Tél: (450) 979-4373 Fax: (450) 979-4626 www.exmweb.com		Flatness Aplatissement Max 3.0mm Projection 
Customer Client	Date	
Drawn By Dessiné Par	BoxCad: BoxCad	Date 23-Mar-21
Material Matière	Polybutylene Terephthalate	
Color Couleur	Light Grey RAL7035	Finish Fini MT-11020
Description		Detail Rev.
5600ESPLHW 20" x 16" Cover		
Part Number Numéro Pièce	Rev.	3
5600ESPLHW201606C	0	3

Qty	Part Name	Rev	Description
1	5600ESPLHW201606LX	0	5600ESPLHW 19.341" x 15.341" Lexan Part
6	STK-Q-03520	2	M6 x 25mm Phillips Screw
1	5600ESPLHW201606C-P	0	5600ESPLHW 20" x 16" x 0" Cover Part
Parts List			

This drawing is confidential and must not be reproduced or used without the consent of EXM

Ce dessin est confidentiel et ne doit pas être reproduit ou utilisé sans le consentement de EXM

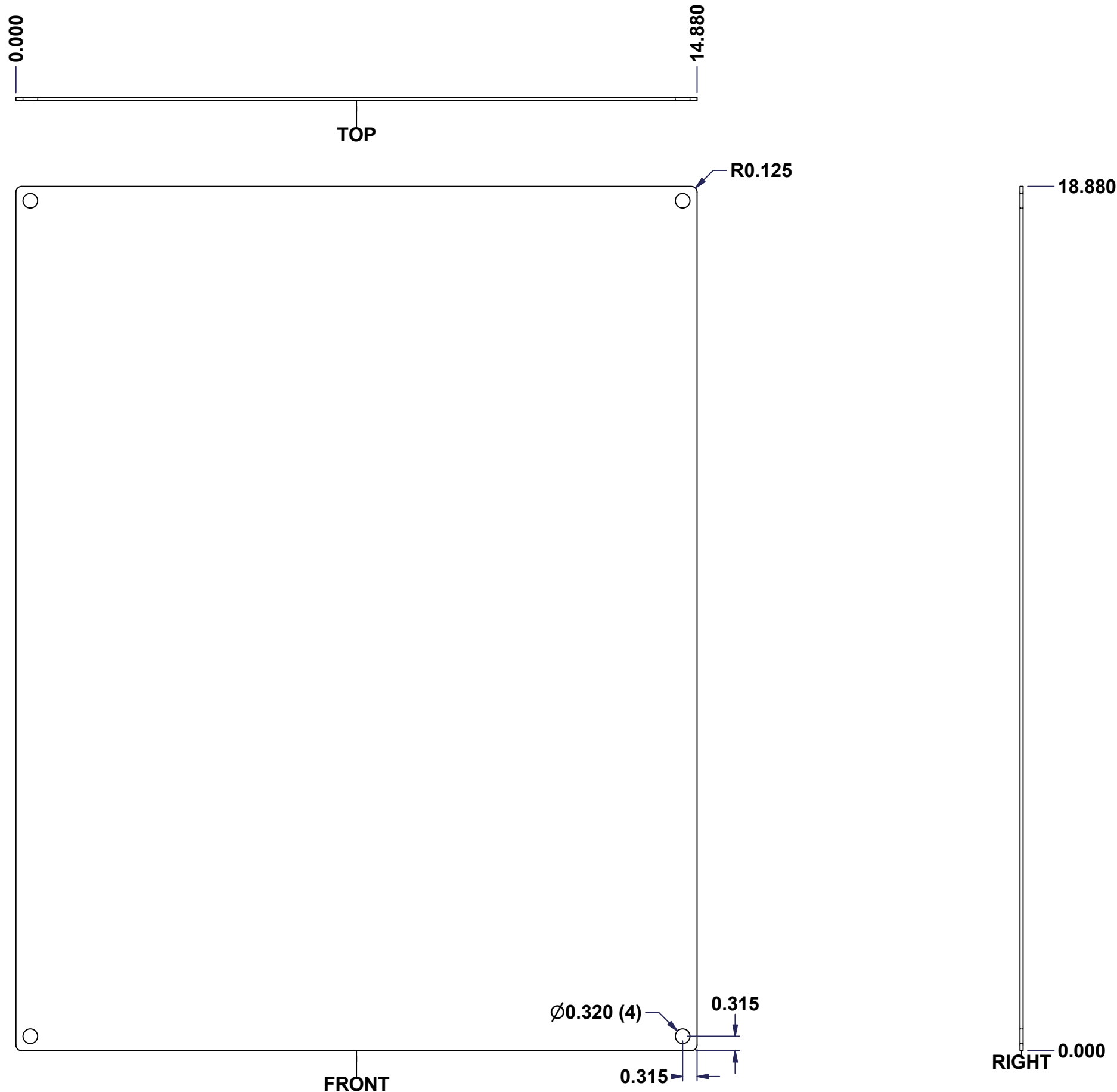

No.	Revisions	Date	By/Par

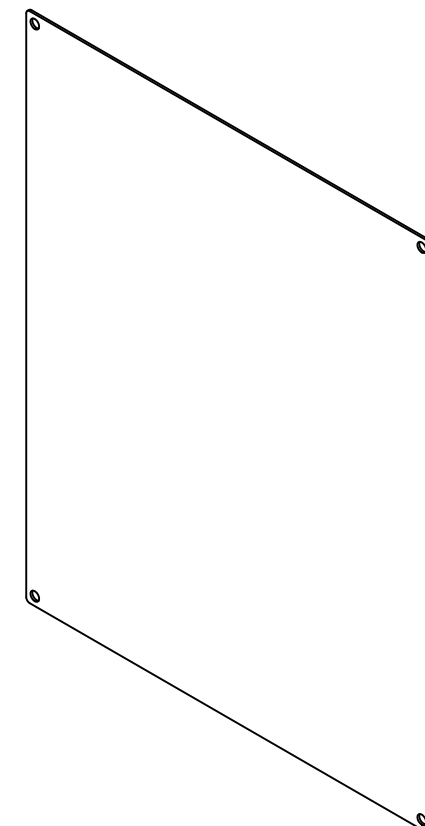

Isometric View

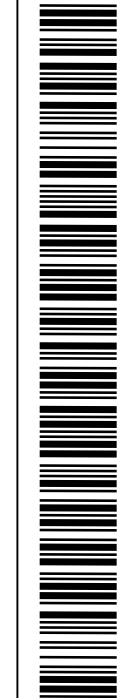

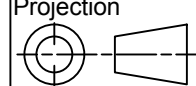
 Tél: (450) 979-4373 Fax: (450) 979-4626 www.exmweb.com		Flatness Aplatissement Max 3.0mm
Projection 		
Customer Client	Date	
Drawn By Dessiné Par: BoxCad	Date: 1/23/2007	
Material Matière: 14 Ga Galvanized (1.7mm)		
Color Couleur: Unpainted	Finish Fini: Galvanized	
Description: 880 SP2016G - Inner Panel		Detail Rev.
Part Number Numéro Pièce: 880 SP2016G	Rev. 0	1/2

SEE BILL OF MATERIAL ON LAST PAGE

This drawing is confidential and must not be reproduced or used without the consent of EXM

Ce dessin est confidentiel et ne doit pas être reproduit ou utilisé sans le consentement de EXM

No.	Revisions	Date	By/Par

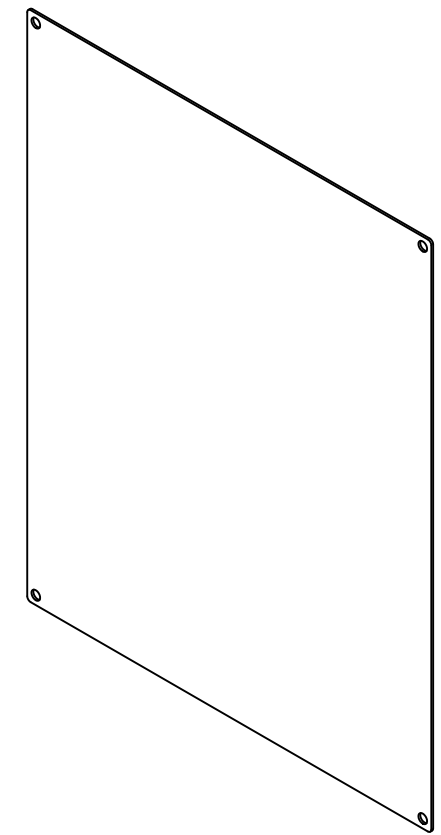

Isometric View

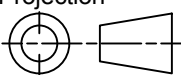

 Tél: (450) 979-4373 Fax: (450) 979-4626 www.exmweb.com		Flatness Aplatissement Max 3.0mm
Customer Client		Projection 
Drawn By / Dessiné Par: BoxCad		Date: 1/23/2007
Material / Matière: 14 Ga Galvanized (1.7mm)		
Color / Couleur: Unpainted	Finish / Fini: Galvanized	
Description: 880 SP2016G - Inner Panel		Detail Rev.
Part Number / Numéro Pièce: 880 SP2016G	Rev.: 0	2 / 2

Qty	Part Number	Rev	Description
1			
Parts List			