

This drawing is confidential and must not be reproduced or used without the consent of EXM

Ce dessin est confidentiel et ne doit pas être reproduit ou utilisé sans le consentement de EXM

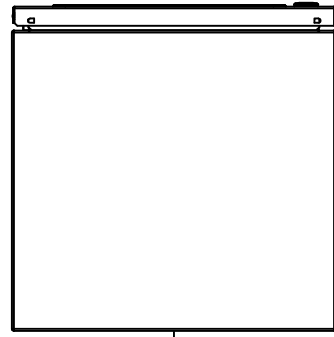

TOP

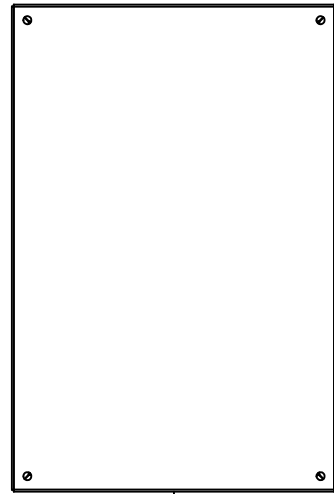

BACK

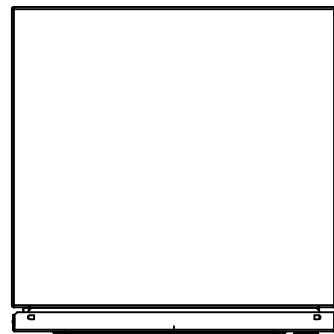

BOTTOM

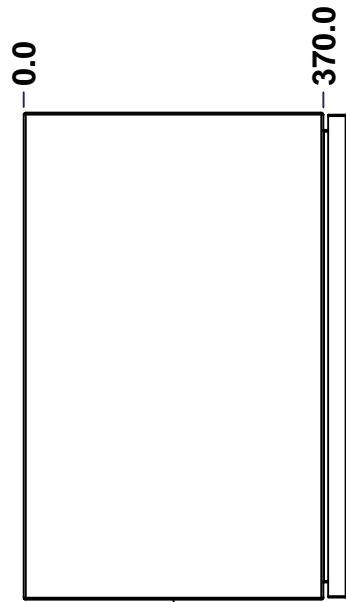

LEFT

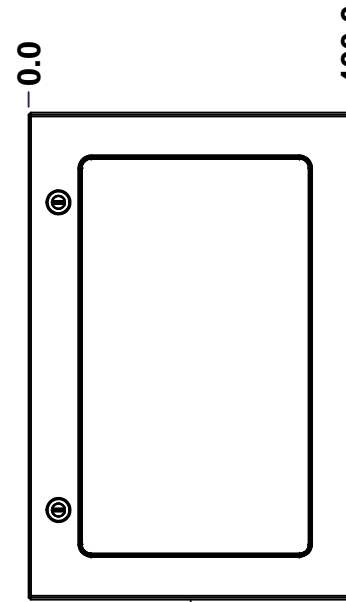

FRONT

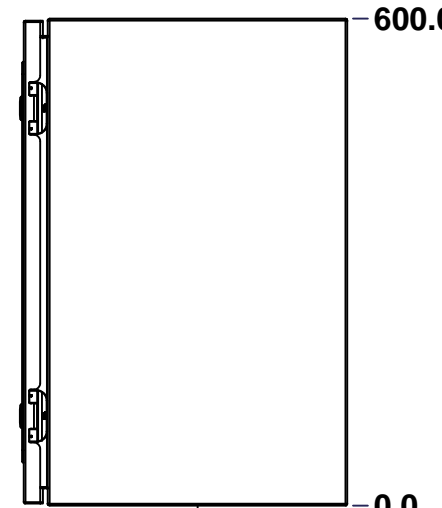

RIGHT

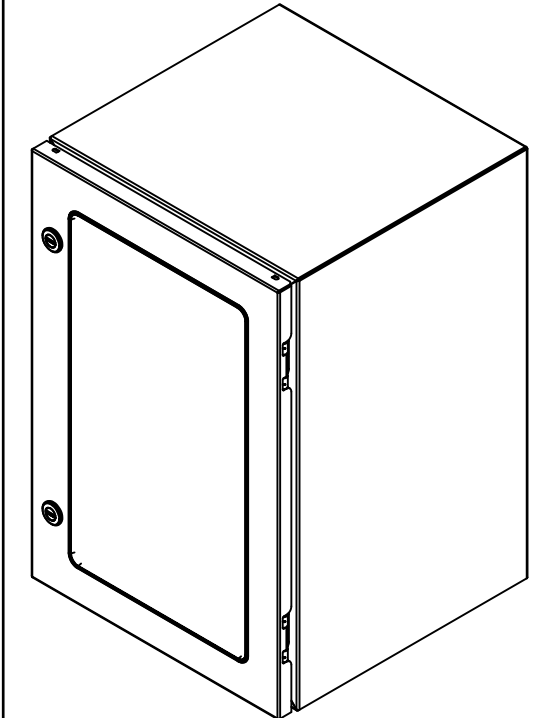

Isometric View

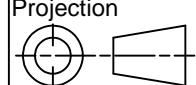

No.	Revisions	Date	By/Par

 Tél: (450) 979-4373 Fax: (450) 979-4626 www.exmweb.com		Flatness Aplatissement Max 3.0mm Projection 
Customer Client	Date	
Drawn By Dessiné Par	BoxCad: Annie	Date 16/09/2014
Material Matière	14 Ga H.R.P. & O. (1.7mm)	
Color Couleur	Light Grey RAL7035	Finish Fin Rough Textured
Description	Detail Rev.	
6412ESW 600mm x 400mm x 370mm Assembly		
Part Number Numéro Pièce	Rev.	1 2
6412ESW040640	0	

SEE BILL OF MATERIAL ON LAST PAGE

This drawing is confidential and must not be reproduced or used without the consent of EXM

Ce dessin est confidentiel et ne doit pas être reproduit ou utilisé sans le consentement de EXM

NOTE	
ITEM	DESCRIPTION
1	NEMA 4/12 Enclosure
2	C/W Standard ground studs on box and cover
3	W/O Standard door stiffener
4	C/W Special inner panel (Sold seperately)
5	C/W Standard inner panel mounting studs

No.	Revisions	Date	By/Par

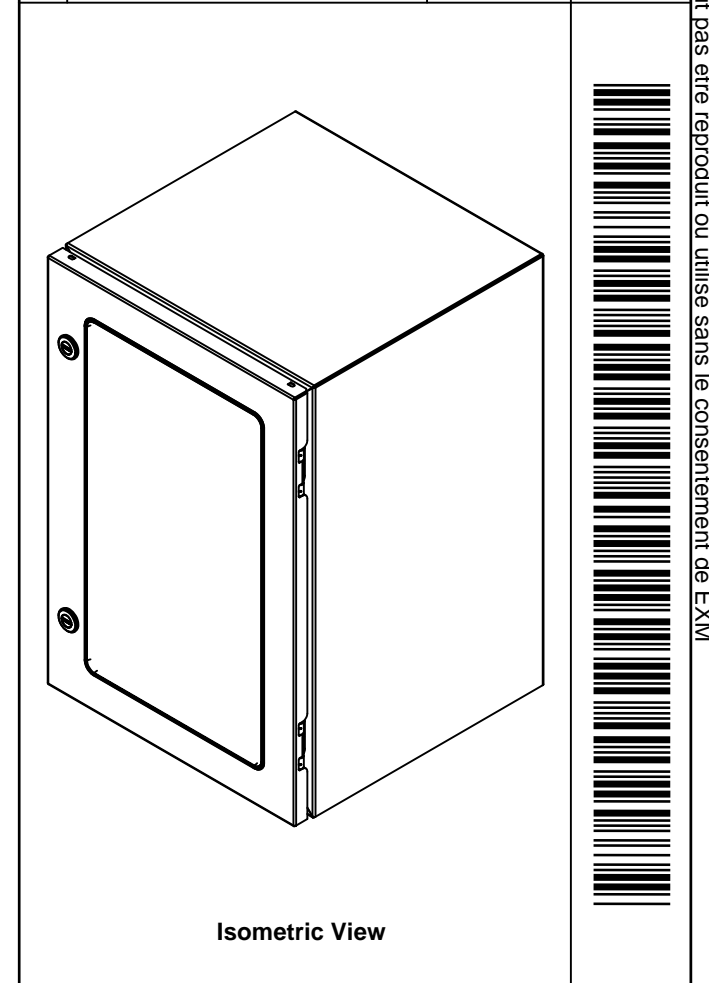

Isometric View

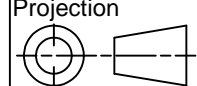
 Tél: (450) 979-4373 Fax: (450) 979-4626 www.exmweb.com		Flatness Aplatissement Max 3.0mm Projection 
Customer Client	Date	
Drawn By Dessiné Par	BoxCad: Annie	Date 16/09/2014
Material Matière	14 Ga H.R.P. & O. (1.7mm)	
Color Couleur	Light Grey RAL7035	Finish Fini Rough Textured
Description	Detail Rev.	
6412ESW 600mm x 400mm x 370mm Assembly		
Part Number Numéro Pièce	Rev. 0	2
6412ESW040640		

Qty	Part Number	Rev	Description
1	STK-K-01800	0	5412 ES Accessory Kit
1	6412ESW040640IP	0	6412ESW 600mm x 400mm Inner Panel Part
1	6412ESW040640C	0	6412ESW 600mm x 400mm Cover
4	STK-Q-07310	2	Flange Lock Nut M8
4	STK-Q-07610	7	M8 Plastic Spacer 22.2mm
1	6412ESW040640B	0	6412ESW 600mm x 400mm x 370mm Body
2	STK-Q-04050-07	5	M6 x 7mm Hexagon Socket Head Machine Screw with Nyseal
Parts List			

This drawing is confidential and must not be reproduced or used without the consent of EXM

Ce dessin est confidentiel et ne doit pas être reproduit ou utilisé sans le consentement de EXM

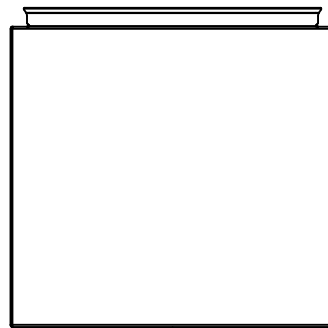

TOP



BACK

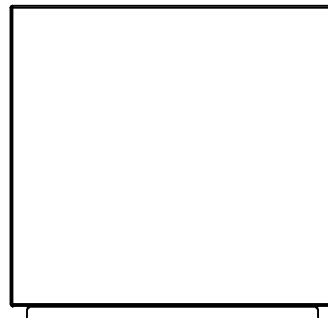

BOTTOM

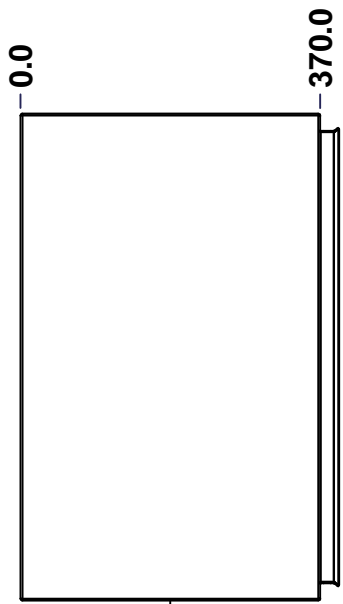

LEFT

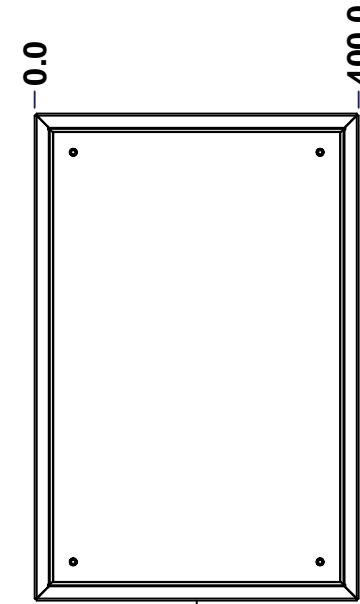

FRONT

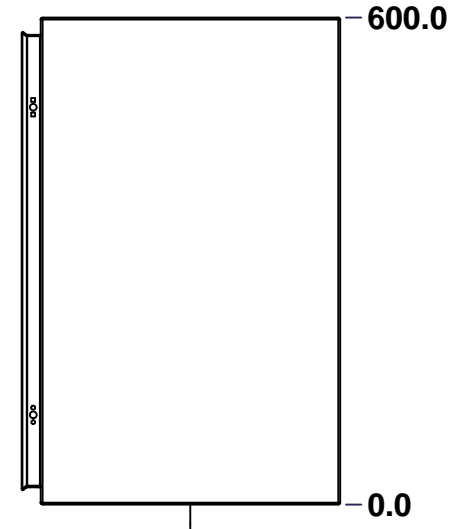

RIGHT

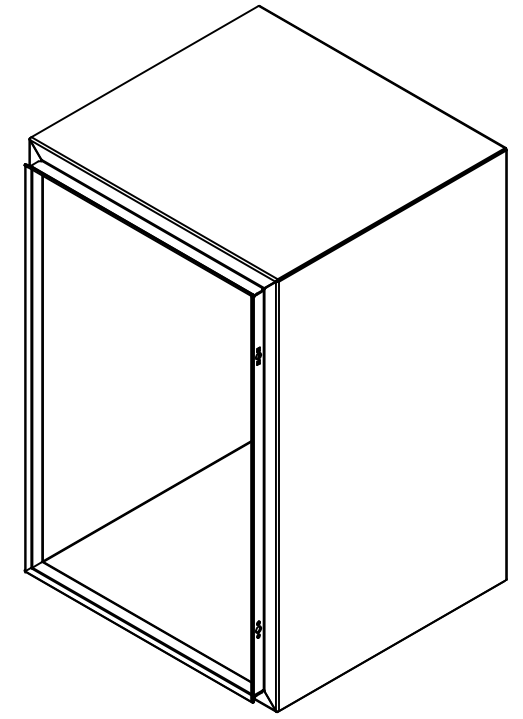

Isometric View

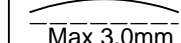

No.	Revisions	Date	By/Par

 Tél: (450) 979-4373 Fax: (450) 979-4626 www.exmweb.com		Flatness Aplatissement  Max 3.0mm
Customer Client		Date
Drawn By Dessiné Par BoxCad: Annie		Date 16/09/2014
Material Matière 14 Ga H.R.P. & O. (1.7mm)		
Color Couleur Light Grey RAL7035	Finish Fini Rough Textured	
Description 6412ESW 600mm x 400mm x 370mm Body		Detail Rev.
Part Number Numéro Pièce 6412ESW040640B		Rev. 1 0 / 7

SEE BILL OF MATERIAL ON LAST PAGE

This drawing is confidential and must not be reproduced or used without the consent of EXM

Ce dessin est confidentiel et ne doit pas être reproduit ou utilisé sans le consentement de EXM

STANDARD FEATURES ARE NOT LISTED IN THIS HOLE TABLE			
HOLE TABLE - RIGHT VIEW (CUSTOM FEATURE ONLY)			
CUT-OUT	XDIM	YDIM	DESCRIPTION
1	331.9	50.8	GND STUD M6 x 16mm (Inside)

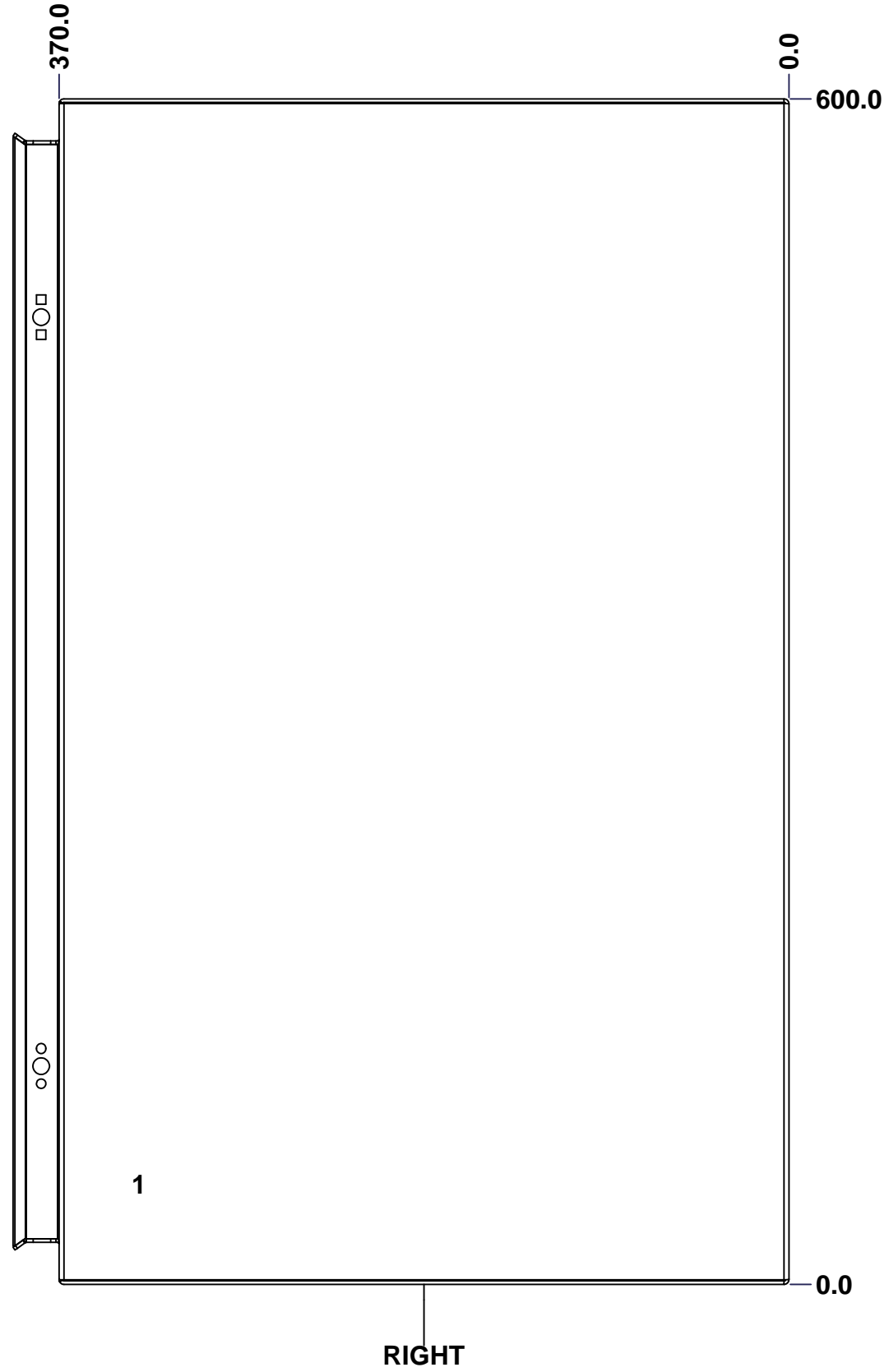

	Description		Status	
	6412ESW 600mm x 400mm x 370mm Body			
Part Number Numéro Pièce		Rev.		
6412ESW040640B		0	3	7

This drawing is confidential and must not be reproduced or used without the consent of EXM

Ce dessin est confidentiel et ne doit pas être reproduit ou utilisé sans le consentement de EXM

STANDARD FEATURES ARE NOT LISTED IN THIS HOLE TABLE

HOLE TABLE - BACK VIEW (CUSTOM FEATURE ONLY)

CUT-OUT	XDIM	YDIM	DESCRIPTION
1	47.6	47.6	IP STUD M8 x 35mm (Inside)
2	47.6	552.4	IP STUD M8 x 35mm (Inside)
3	352.4	552.4	IP STUD M8 x 35mm (Inside)
4	352.4	47.6	IP STUD M8 x 35mm (Inside)

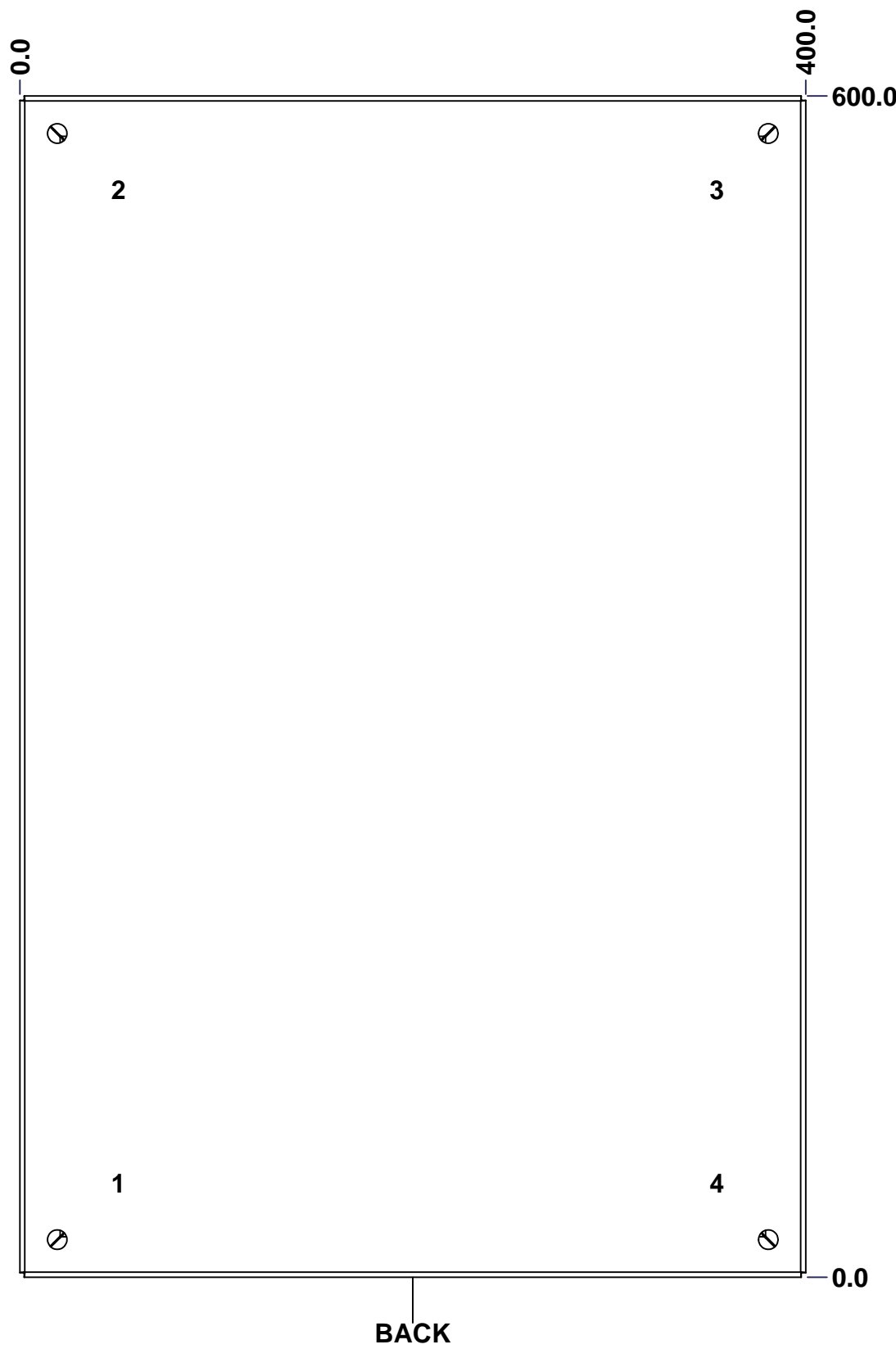

	Description		Status	
	6412ESW 600mm x 400mm x 370mm Body			
	Part Number Numéro Pièce		Rev.	
	6412ESW040640B		0	6 7

This drawing is confidential and must not be reproduced or used without the consent of EXM

Ce dessin est confidentiel et ne doit pas être reproduit ou utilisé sans le consentement de EXM

No.	Revisions	Date	By/Par

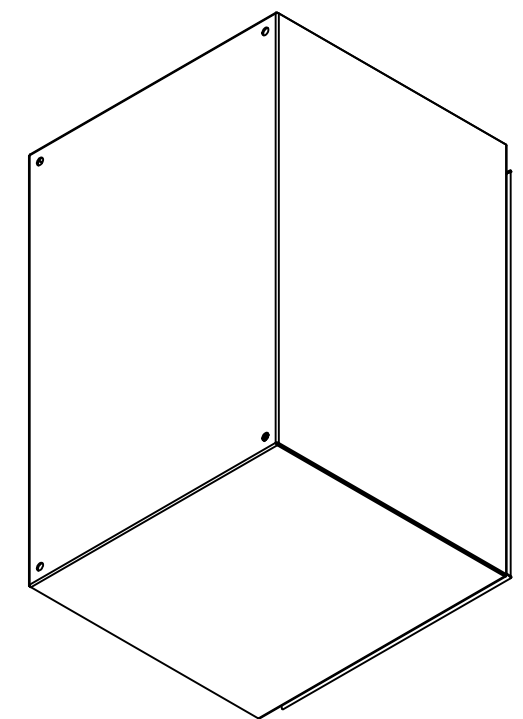

Isometric View

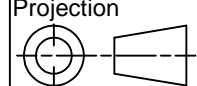

 Tél: (450) 979-4373 Fax: (450) 979-4626 www.exmweb.com		Flatness Aplatissement Max 3.0mm Projection 
Customer Client	Date	
Drawn By Dessiné Par	BoxCad: Annie	Date 16/09/2014
Material Matière	14 Ga H.R.P. & O. (1.7mm)	
Color Couleur	Light Grey RAL7035	Finish Fini
Description		Detail Rev.
6412ESW 600mm x 400mm x 370mm Body		
Part Number Numéro Pièce	Rev.	7
6412ESW040640B	0	7

Qty	Part Number	Rev	Description
1	STK-P-03820R	0	Powder Paint (Light Grey / Rough Textured)
4	STK-Q-16005	1	Stud M8 x 35 (No Paint Cap Required)
1	STK-Q-16080	0.1.1	M6 x 16mm Ground Stud
1	6412ESW040640B-P	0	6412ESW 600mm x 400mm x 370mm Body Part
Parts List			

This drawing is confidential and must not be reproduced or used without the consent of EXM

Ce dessin est confidentiel et ne doit pas être reproduit ou utilisé sans le consentement de EXM

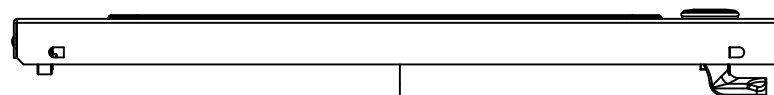

TOP

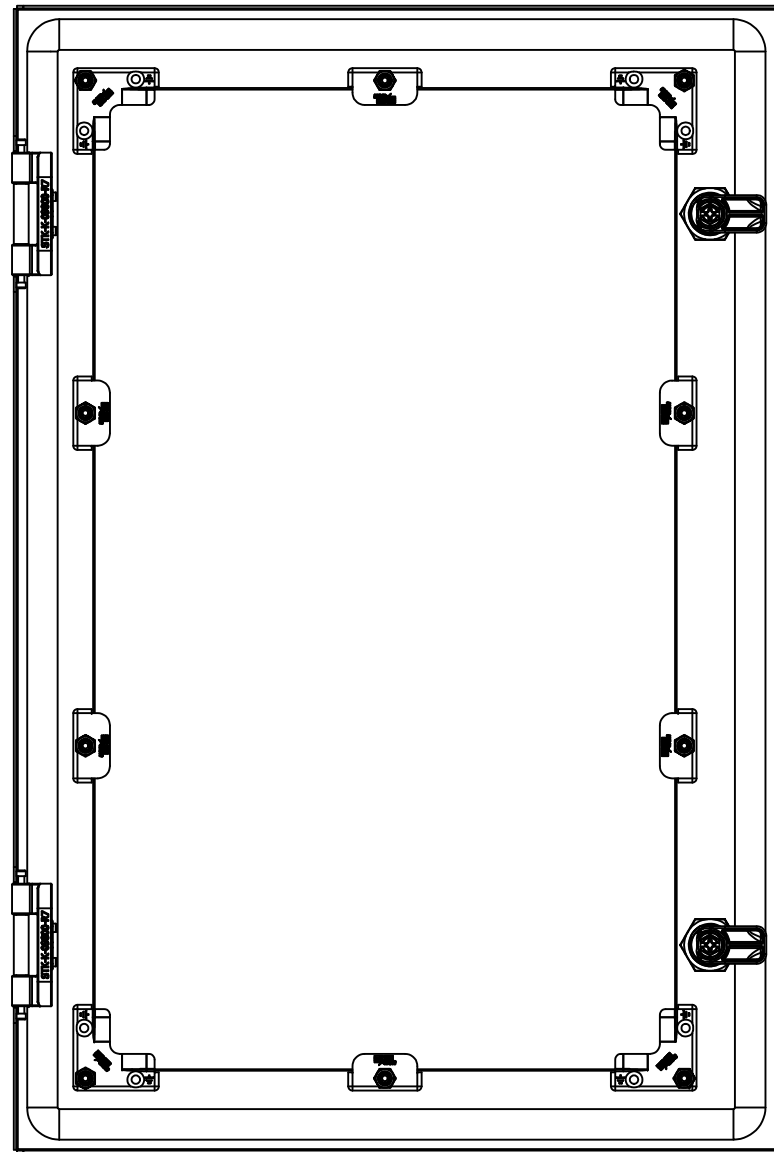

BACK

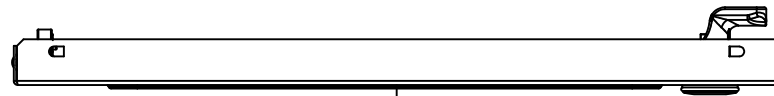

BOTTOM



LEFT

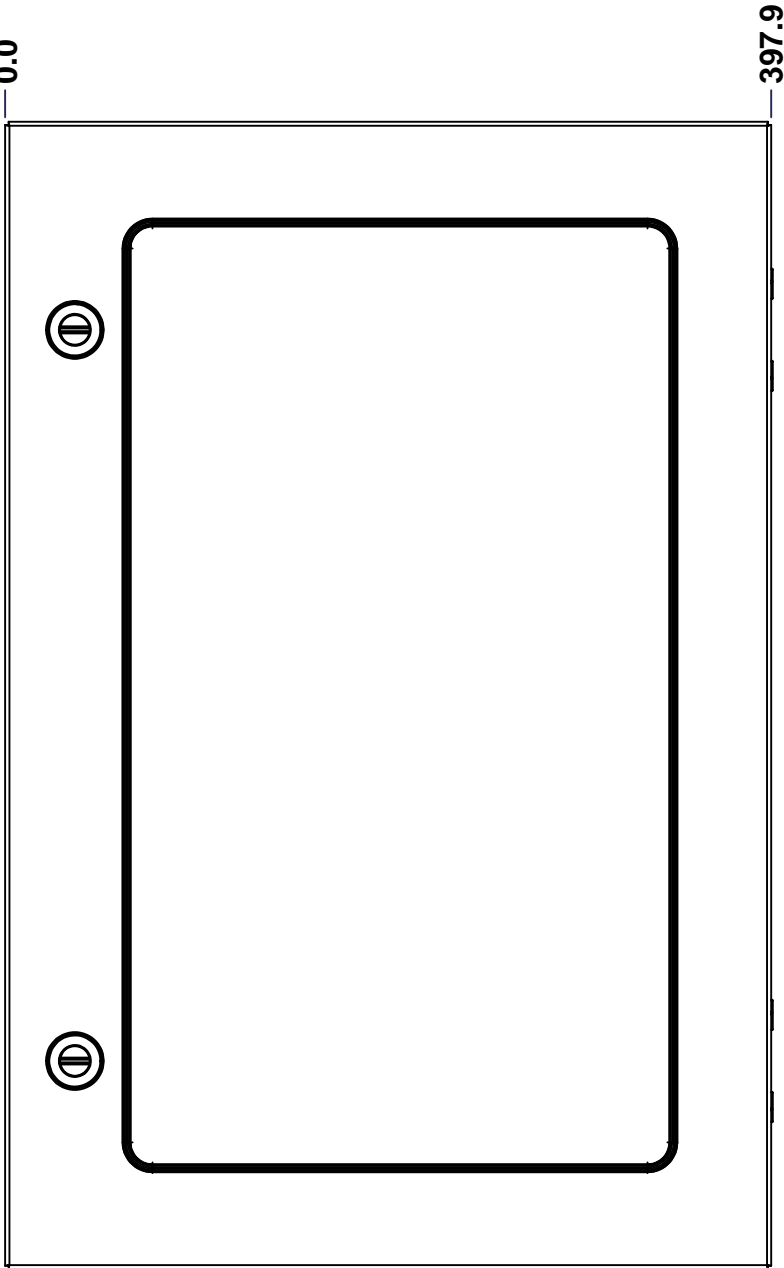

FRONT

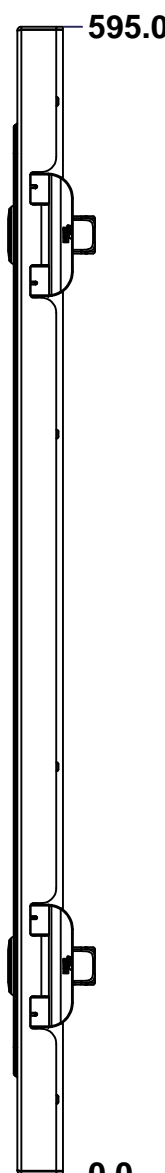

RIGHT

No.	Revisions	Date	By/Par

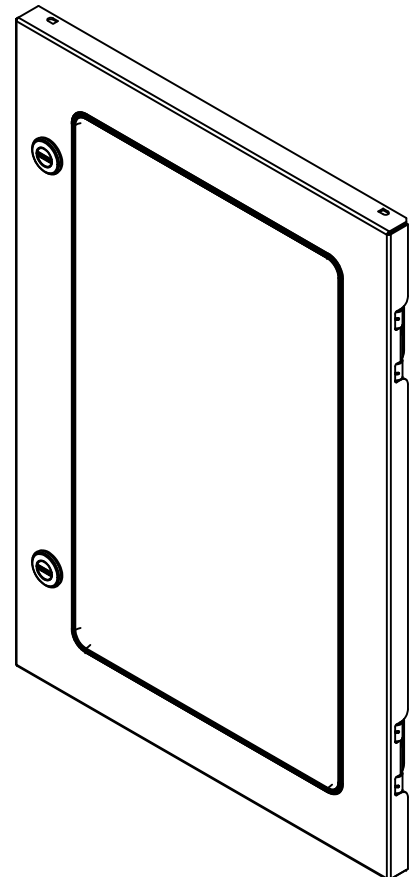

Isometric View



Tél: (450) 979-4373
 Fax: (450) 979-4626
www.exmweb.com

Flatness
Aplatissement
Max 3.0mm
Projection

Customer Client	Date
Drawn By Dessiné Par BoxCad: Annie	Date 16/09/2014
Material Matière 16 Ga H.R.P. & O. (1.4mm)	
Color Couleur Light Grey RAL7035	Finish Fini Rough Textured
Description 6412ESW 600mm x 400mm Cover	Detail Rev.
Part Number Numéro Pièce 6412ESW040640C	Rev. 0

SEE BILL OF MATERIAL ON LAST PAGE

1
3

This drawing is confidential and must not be reproduced or used without the consent of EXM

Ce dessin est confidentiel et ne doit pas être reproduit ou utilisé sans le consentement de EXM

STANDARD FEATURES ARE NOT LISTED IN THIS HOLE TABLE

HOLE TABLE - FRONT VIEW (CUSTOM FEATURE ONLY)

CUT-OUT	XDIM	YDIM	DESCRIPTION
1	360.6	211.3	STUD M6 x 18mm (Inside)
2	49.5	211.3	STUD M6 x 18mm (Inside)
3	360.6	383.7	STUD M6 x 18mm (Inside)
4	49.5	383.7	STUD M6 x 18mm (Inside)
5	49.5	556.2	STUD M6 x 18mm (Inside)
6	49.5	38.8	STUD M6 x 18mm (Inside)
7	208.2	556.2	STUD M6 x 18mm (Inside)
8	208.2	38.8	STUD M6 x 18mm (Inside)
9	367.0	556.2	STUD M6 x 18mm (Inside)
10	367.0	38.8	STUD M6 x 18mm (Inside)

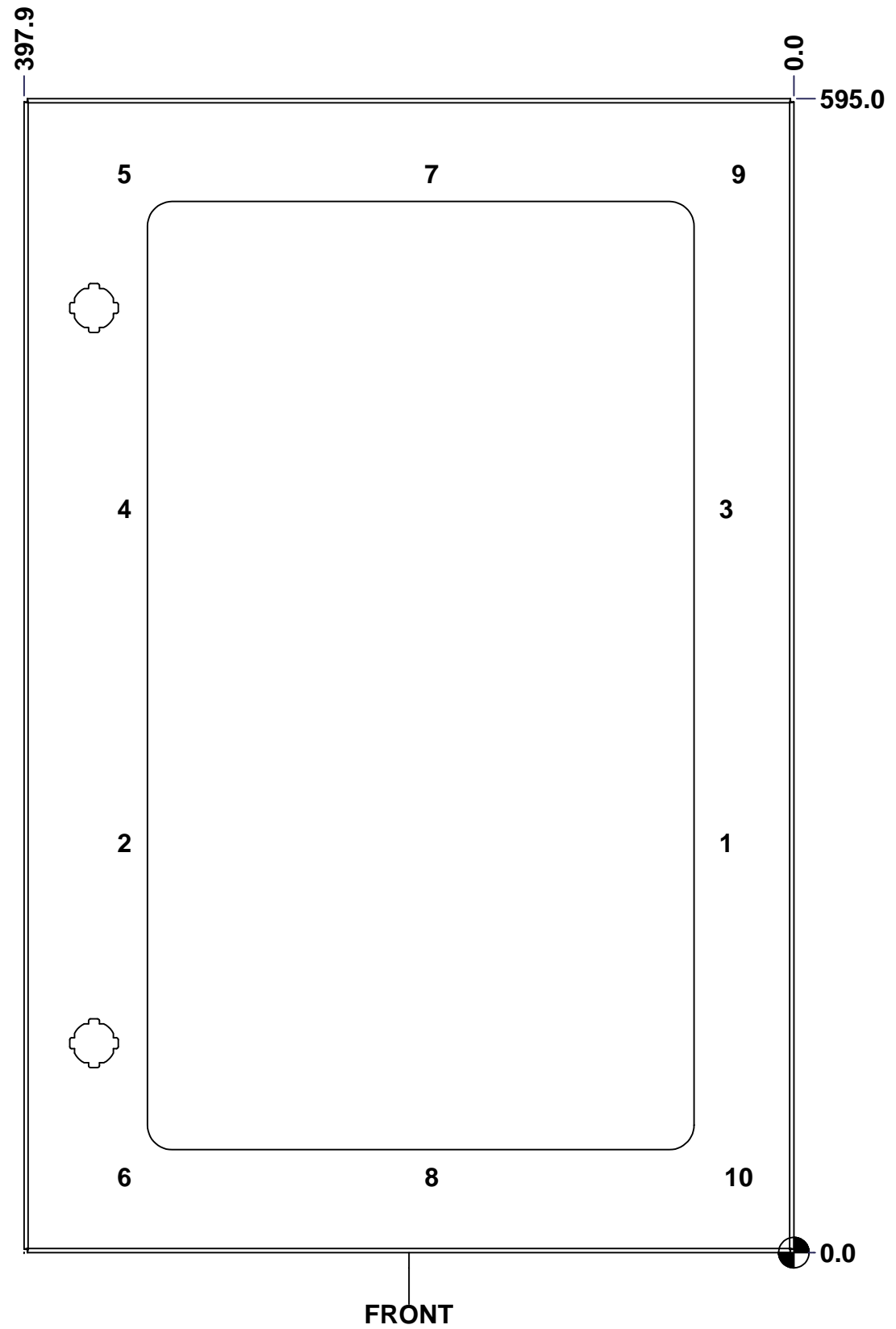

	Description	Status
	6412ESW 600mm x 400mm Cover	(NULL)
	Part Number Numéro Pièce	Rev.
	6412ESW040640C	0
		2
		3

This drawing is confidential and must not be reproduced or used without the consent of EXM

Ce dessin est confidentiel et ne doit pas être reproduit ou utilisé sans le consentement de EXM

No.	Revisions	Date	By/Par

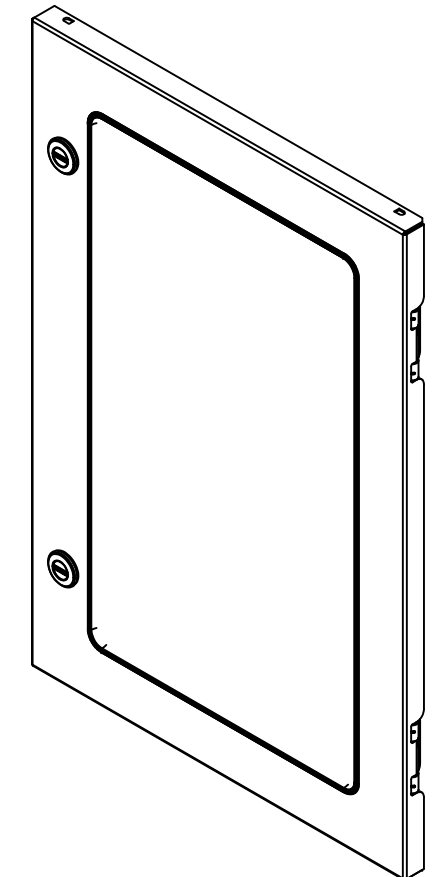

Isometric View



Qty	Part Name	Rev	Description
1	STK-P-03820R	0	Powder Paint (Light Grey / Rough Textured)
10	STK-Q-16055	1	M6 x 18mm Stud (No Paint Cap Required)
1	STK-G-02705	0	880 HWKG - Windows Kit Gasket
1	6412ESW040640LXG	0	6412ESW 23.6220472440945" x 15.748031496063" Lexan Gasket
1	6412ESW040640LX	0	6412ESW 23.6220472440945" x 15.748031496063" Window Lexan
1	STK-A-60703	0	5412 ESW Lexan Bracket Kit
1	6412ESW040640G	0	6412ESW 23.6220472440945" x 15.748031496063" Cover Gasket
1	6412ESW040640C-P	0	6412ESW 600mm x 400mm Cover Part
2	880 SCQ4-SL	0	5412 ES 1/4 Turn Lock
2	STK-K-09800	5	5412 ES Hinge with 2 Captive Hinge Pins
6	STK-Q-60700	3	880 WK Lexan 1/4" Fixing Bracket
Parts List			



Tél: (450) 979-4373
 Fax: (450) 979-4626
www.exmweb.com

Flatness
Aplatissement
Max 3.0mm

Projection

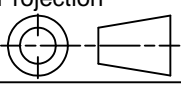

Customer Client		Date
Drawn By Dessiné Par	BoxCad: Annie	Date 16/09/2014
Material Matière 16 Ga H.R.P. & O. (1.4mm)		
Color Couleur	Light Grey RAL7035	Finish Fini Rough Textured
Description 6412ESW 600mm x 400mm Cover		Detail Rev.
Part Number Numéro Pièce 6412ESW040640C		Rev. 3 0

This drawing is confidential and must not be reproduced or used without the consent of EXM

Ce dessin est confidentiel et ne doit pas être reproduit ou utilisé sans le consentement de EXM

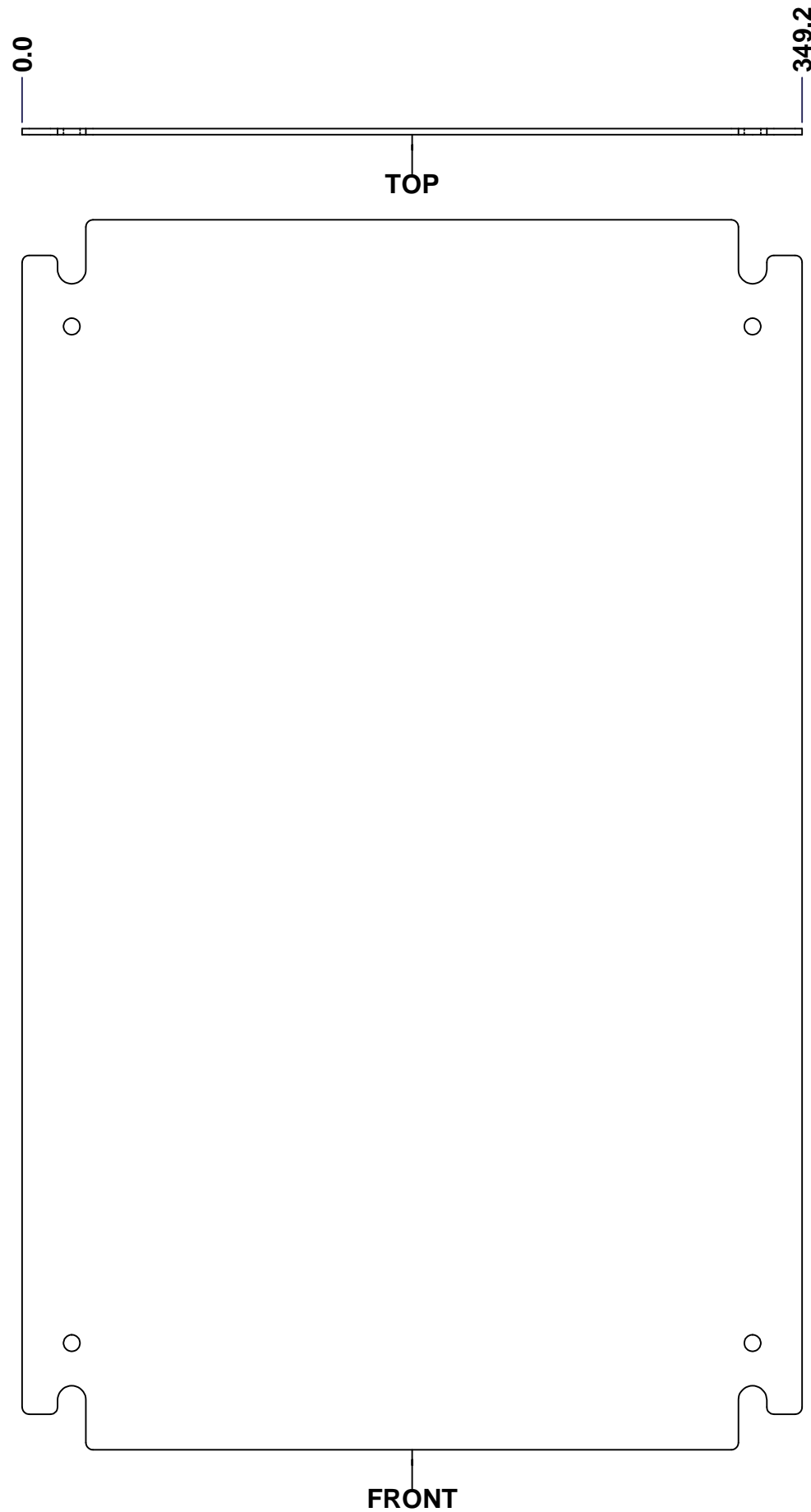

No.	Revisions	Date	By/Par

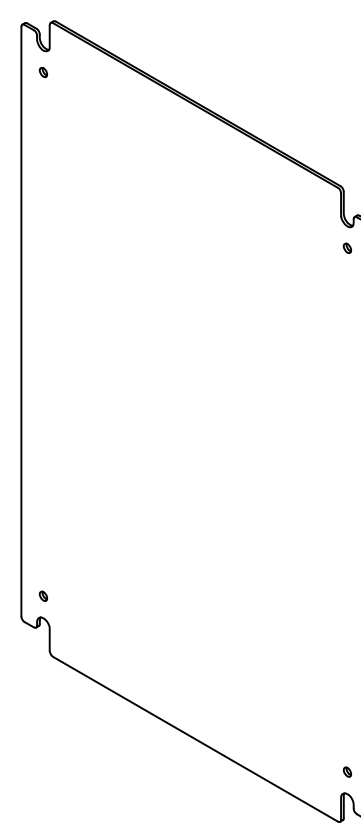

Isometric View

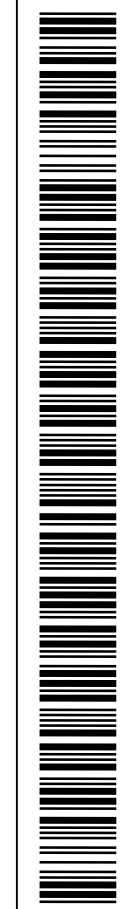

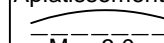
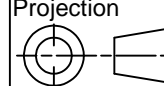
 Tél: (450) 979-4373 Fax: (450) 979-4626 www.exmweb.com		Flatness Aplatissement  Max 3.0mm	
		Projection 	
Customer Client		Date	
Drawn By Dessiné Par BoxCad: Annie		Date 16/09/2014	
Material Matière 12 Ga Galvanized (2.5mm)			
Color Couleur Unpainted		Finish Fini Unpainted	
Description 6412ESW 600mm x 400mm Inner Panel Part			Detail Rev.
Part Number Numéro Pièce 6412ESW040640IP		Rev. 0	1 / 3

SEE BILL OF MATERIAL ON LAST PAGE

This drawing is confidential and must not be reproduced or used without the consent of EXM

Ce dessin est confidentiel et ne doit pas être reproduit ou utilisé sans le consentement de EXM

No.	Revisions	Date	By/Par

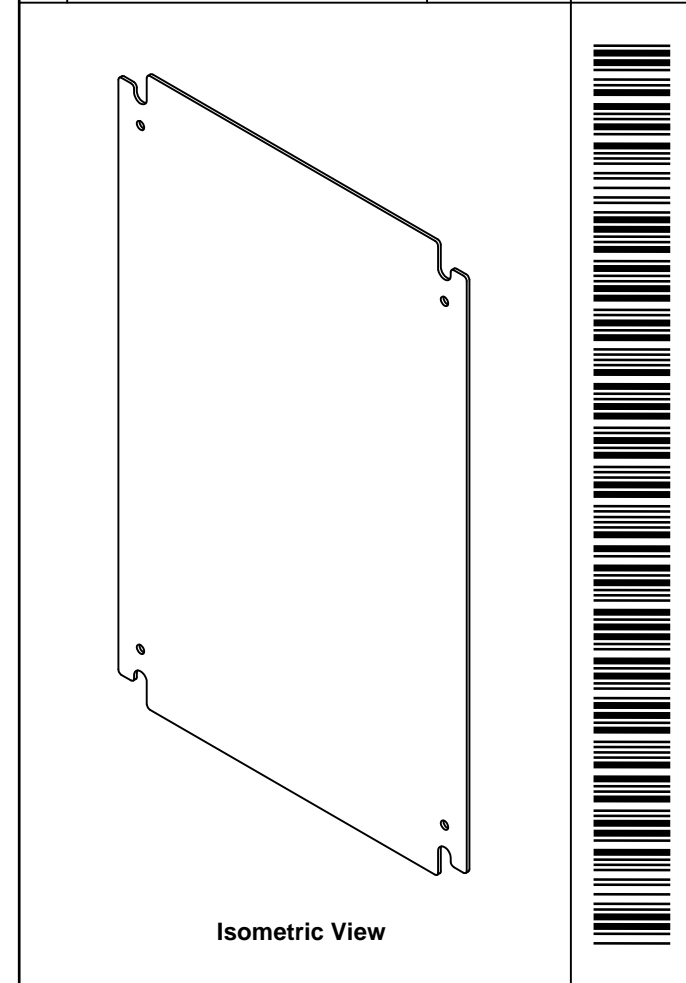

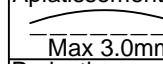
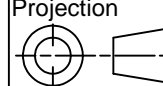
 Tél: (450) 979-4373 Fax: (450) 979-4626 www.exmweb.com		Flatness Aplatissement  Max 3.0mm Projection 
Customer Client	Date	
Drawn By Dessiné Par	BoxCad: Annie	Date 16/09/2014
Material Matière	12 Ga Galvanized (2.5mm)	
Color Couleur	Unpainted	Finish Fini Unpainted
Description	Detail Rev.	
6412ESW 600mm x 400mm Inner Panel Part		
Part Number Numéro Pièce	Rev.	3
6412ESW040640IP	0	3

Qty	Part Number	Rev	Description
1	6412ESW040640IP-P	0	6412ESW 600mm x 400mm Inner Panel Part
Parts List			