

This drawing is confidential and must not be reproduced or used without the consent of EXM

Ce dessin est confidentiel et ne doit pas être reproduit ou utilisé sans le consentement de EXM

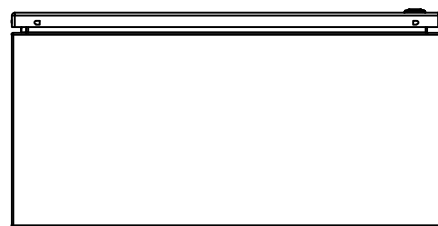

TOP



BACK

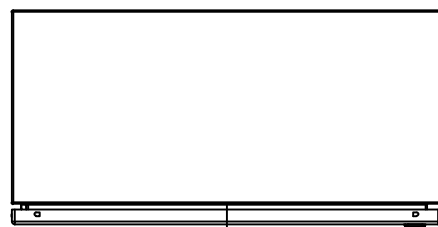

BOTTOM

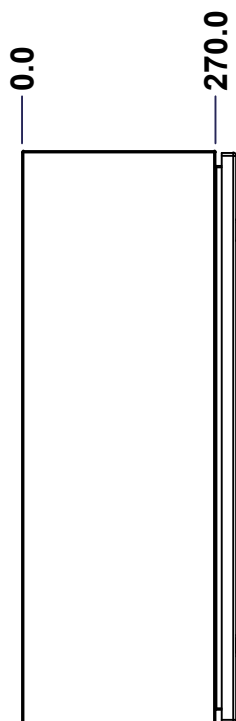

LEFT

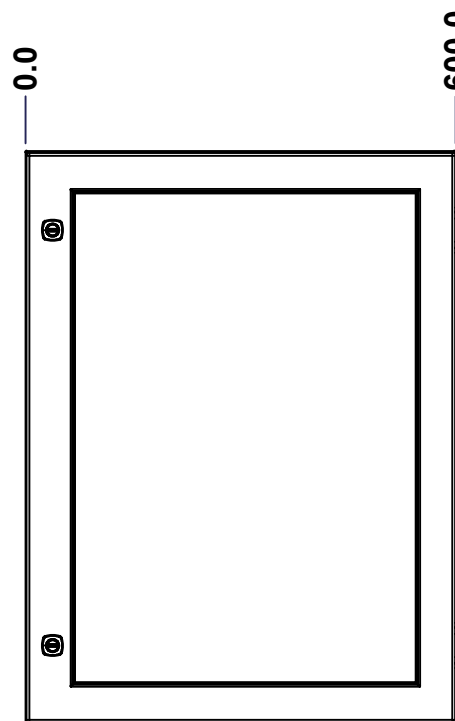

FRONT

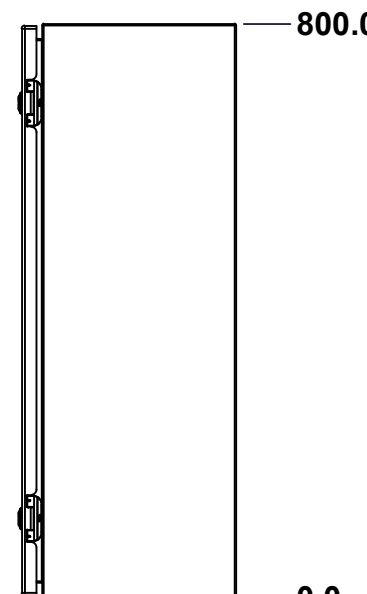

RIGHT

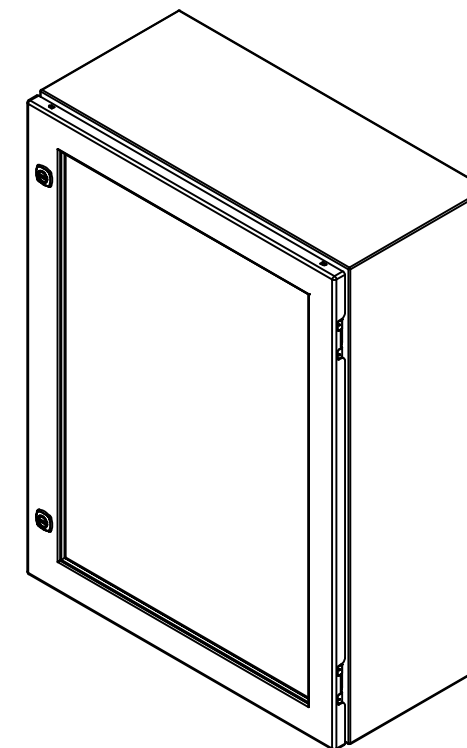

Isometric View

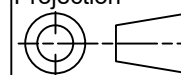

No.	Revisions	Date	By/Par

 Tél: (450) 979-4373 Fax: (450) 979-4626 <a href="http://www.exmweb.com">www.exmweb.com</a>		Flatness Aplatissement Max 3.0mm Projection 
Customer Client	Date	
Drawn By Dessiné Par	BoxCad: BoxCad	Date 15-Aug-14
Material Matière	16 Ga Cold Rolled A1008 CS Type B (1.4mm)	
Color Couleur	Light Grey RAL7035	Finish Fini Textured
Description	Detail Rev.	
6412ESW 800mm x 600mm x 270mm Assembly		
Part Number Numéro Pièce	Rev.	1
<b>6412ESW060830</b>	<b>0</b>	9

SEE BILL OF MATERIAL ON LAST PAGE

This drawing is confidential and must not be reproduced or used without the consent of EXM

Ce dessin est confidentiel et ne doit pas être reproduit ou utilisé sans le consentement de EXM

NOTE	
ITEM	DESCRIPTION
1	NEMA 4, 12 Enclosure (IP66)
2	C/W Standard ground studs on box and cover
3	W/O Standard door stiffener
4	C/W Standard inner panel (Included)
5	C/W Standard inner panel mounting studs

No.	Revisions	Date	By/Par

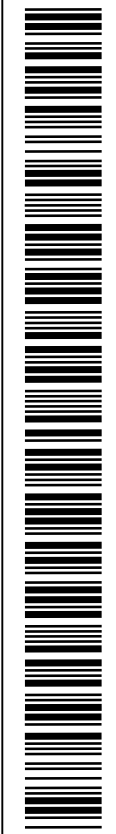
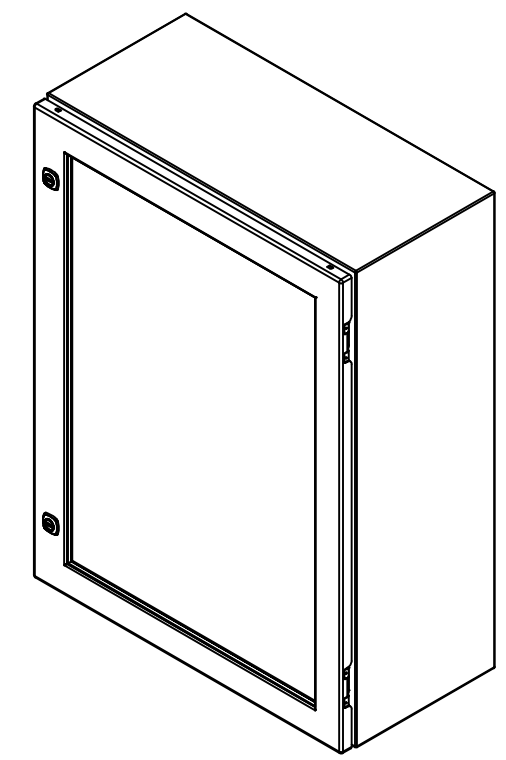

Isometric View



Tél: (450) 979-4373  
 Fax: (450) 979-4626  
[www.exmweb.com](http://www.exmweb.com)

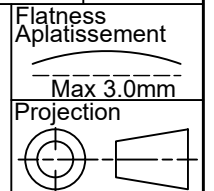

Customer Client	Date
Drawn By / Dessiné Par: BoxCad: BoxCad	Date: 15-Aug-14
Material / Matière: 16 Ga Cold Rolled A1008 CS Type B (1.4mm)	

Color / Couleur: Light Grey RAL7035	Finish / Fini: Textured
Description: 6412ESW 800mm x 600mm x 270mm Assembly	Detail Rev.
Part Number / Numéro Pièce: <b>6412ESW060830</b>	Rev. 0

PACKING		
ITEM	QTY	DESCRIPTION
Cardboard sleeve	2	Top and Bottom
Cardboard strip	2	Between back of enclosure and inner panel
Plastic bag	1	To protect cover surface and inside gasket
Plastic strap - Black	2	To Squeeze the 2 cardboard sleeve together
Packaging label	1	White label with product number

Qty	Part Number	Rev	Description
1	886 SP0608ES	0	886 SP - Inner Panel
2	STK-K-01320	0	5412 ES Inner Panel Accessory Kit
1	STK-K-01800	5	5412 ES Accessory Kit
1	6412ESW060830C	0	6412ESW 800mm x 600mm Cover
1	6412ESW060830B	0	6412ESW 800mm x 600mm x 270mm Body
2	STK-Q-04050-08	0	M6 x 8mm Hexagon Socket Head Machine Screw

Parts List

This drawing is confidential and must not be reproduced or used without the consent of EXM

Ce dessin est confidentiel et ne doit pas être reproduit ou utilisé sans le consentement de EXM

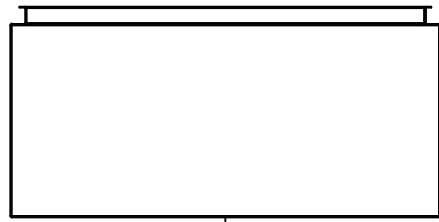

TOP

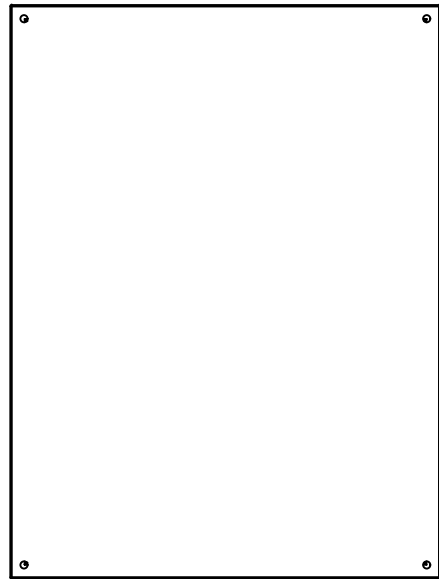

BACK



BOTTOM

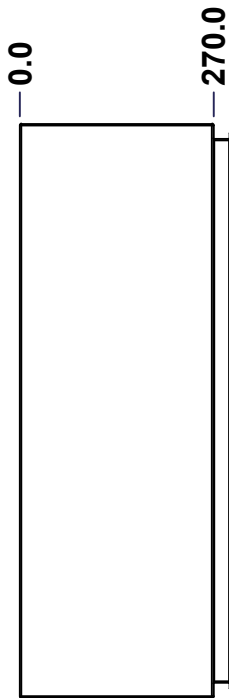

LEFT

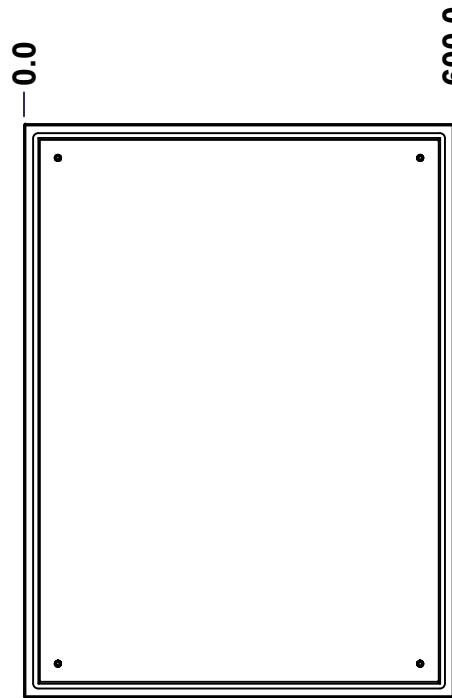

FRONT

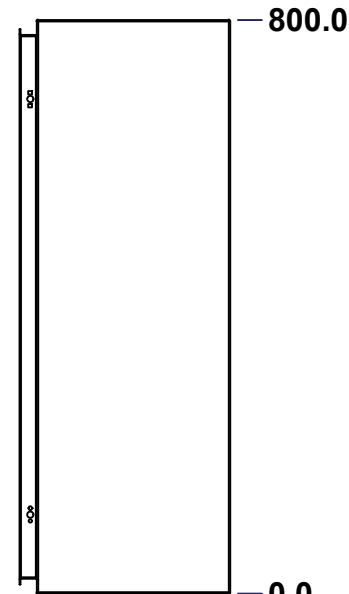

RIGHT

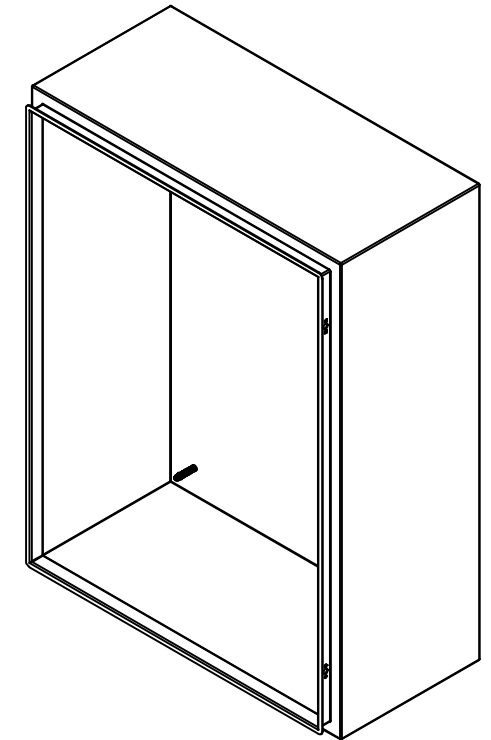

Isometric View

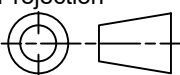

No.	Revisions	Date	By/Par

 Tél: (450) 979-4373 Fax: (450) 979-4626 <a href="http://www.exmweb.com">www.exmweb.com</a>		Flatness Aplatissement Max 3.0mm Projection 
Customer Client	Date	
Drawn By Dessiné Par	BoxCad: BoxCad	Date 15-Aug-14
Material Matière	16 Ga Cold Rolled A1008 CS Type B (1.4mm)	
Color Couleur	Light Grey RAL7035	Finish Fini Textured
Description 6412ESW 800mm x 600mm x 270mm Body		Detail Rev.
Part Number Numéro Pièce	6412ESW060830B	Rev. 3 0 9

SEE BILL OF MATERIAL ON LAST PAGE

This drawing is confidential and must not be reproduced or used without the consent of EXM

Ce dessin est confidentiel et ne doit pas être reproduit ou utilisé sans le consentement de EXM

STANDARD FEATURES ARE NOT LISTED IN THIS HOLE TABLE			
HOLE TABLE - RIGHT VIEW (CUSTOM FEATURE ONLY)			
CUT-OUT	XDIM	YDIM	DESCRIPTION
1	231.9	50.8	GND STUD M6 x 16mm (Inside)
2	219.2	749.2	LABEL_EXM (Inside)

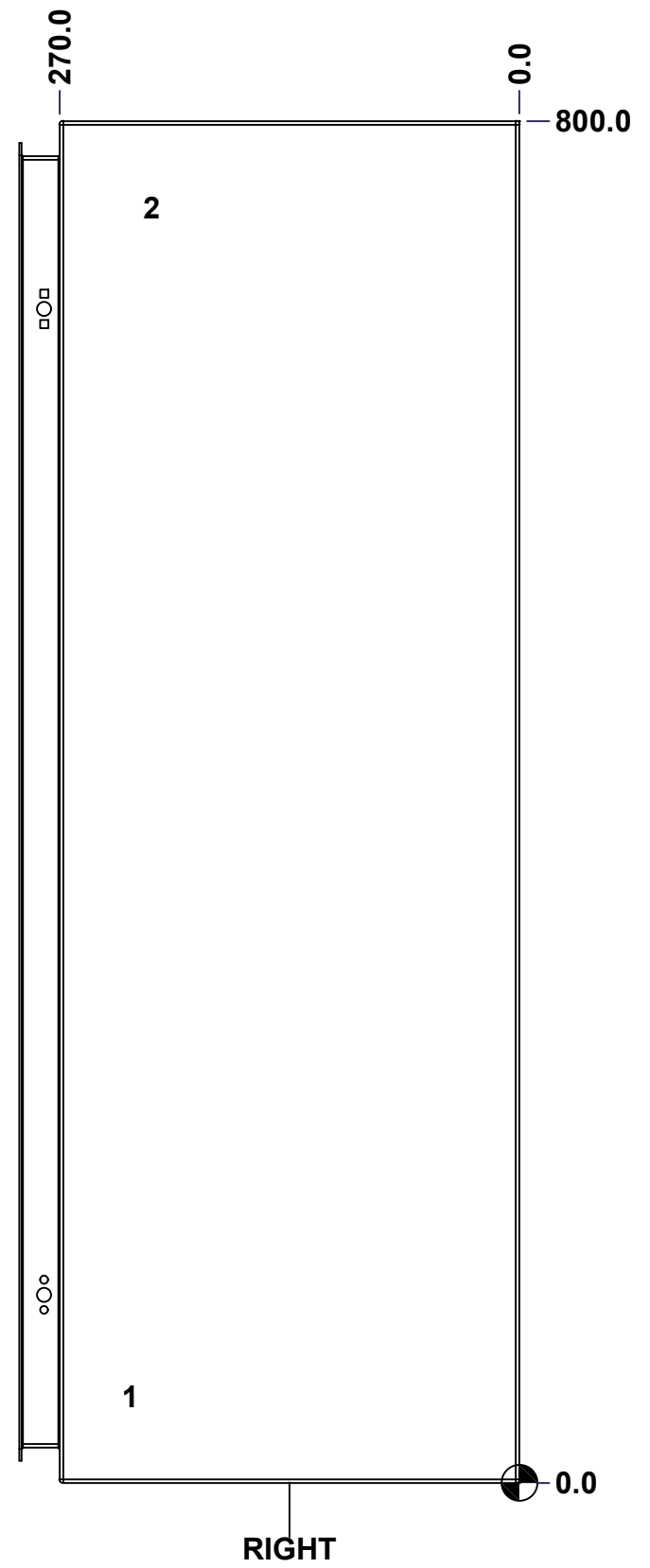

	Description 6412ESW 800mm x 600mm x 270mm Body	Status (NULL)
	Part Number Numéro Pièce <b>6412ESW060830B</b>	Rev. 4 <b>0</b> / 9

This drawing is confidential and must not be reproduced or used without the consent of EXM

Ce dessin est confidentiel et ne doit pas être reproduit ou utilisé sans le consentement de EXM

**STANDARD FEATURES ARE NOT LISTED IN THIS HOLE TABLE**

**HOLE TABLE - BACK VIEW (CUSTOM FEATURE ONLY)**

CUT-OUT	XDIM	YDIM	DESCRIPTION
1	47.6	47.6	IP STUD M8 x 35mm (Inside)
2	47.6	752.4	IP STUD M8 x 35mm (Inside)
3	552.4	752.4	IP STUD M8 x 35mm (Inside)
4	552.4	47.6	IP STUD M8 x 35mm (Inside)
-----			
5	581.0	19.1	RND Ø9.9
6	581.0	781.0	RND Ø9.9
7	19.1	781.0	RND Ø9.9
8	19.1	19.1	RND Ø9.9

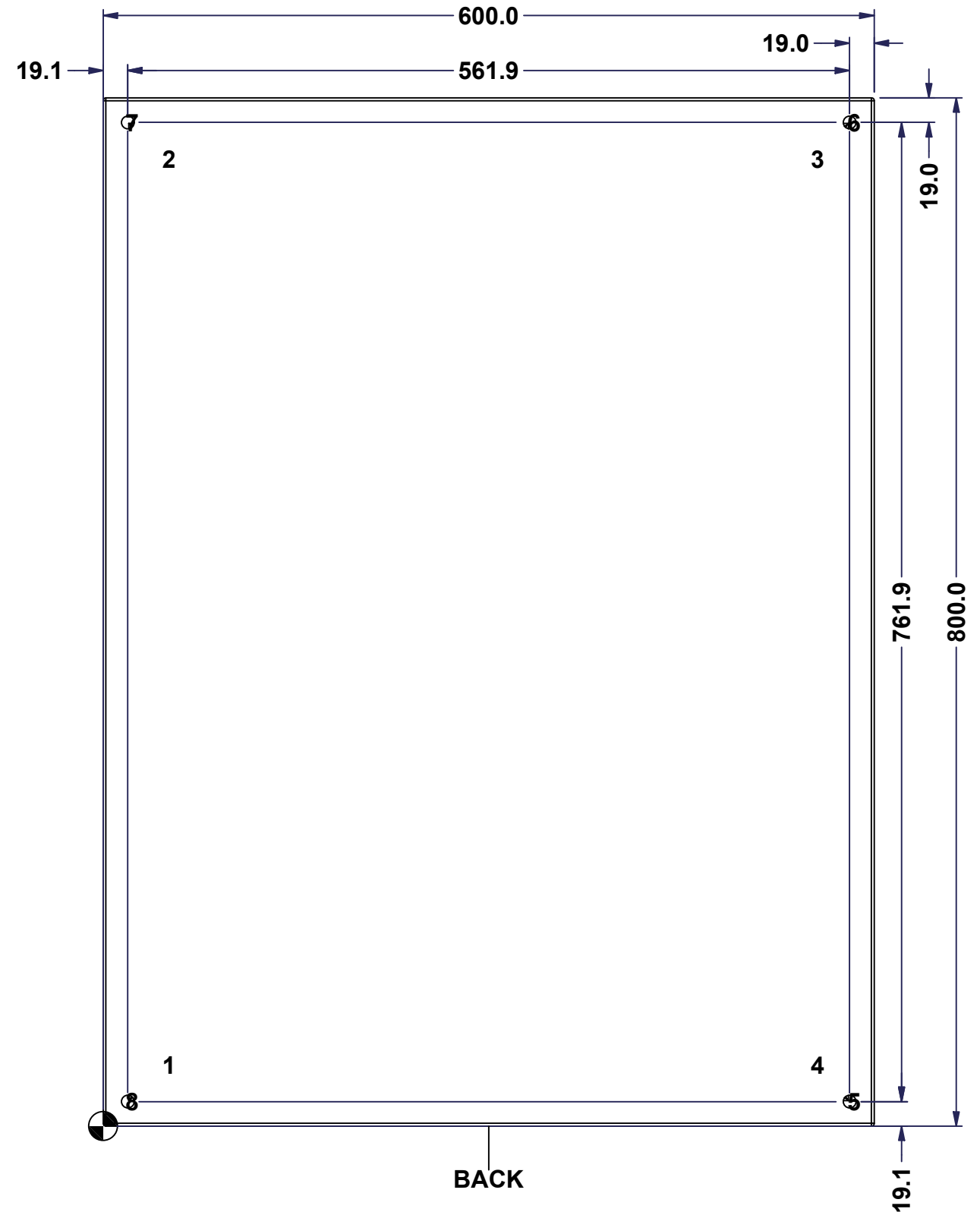

BACK

	Description 6412ESW 800mm x 600mm x 270mm Body	Status (NULL)
	Part Number Numéro Pièce <b>6412ESW060830B</b>	Rev. 5 <b>0</b> / 9

This drawing is confidential and must not be reproduced or used without the consent of EXM

Ce dessin est confidentiel et ne doit pas être reproduit ou utilisé sans le consentement de EXM

No.	Revisions	Date	By/Par

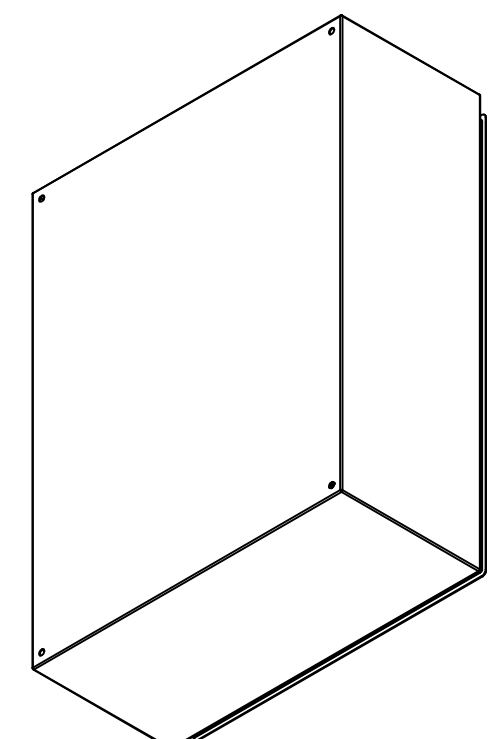

Isometric View

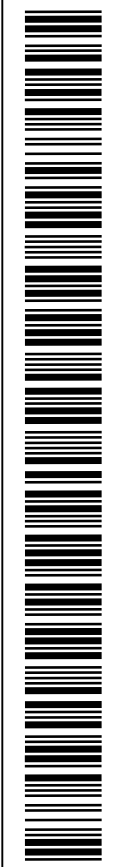

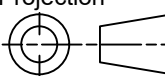
 Tél: (450) 979-4373 Fax: (450) 979-4626 <a href="http://www.exmweb.com">www.exmweb.com</a>		Flatness Aplatissement Max 3.0mm Projection 
Customer Client	Date	
Drawn By / Dessiné Par: BoxCad: BoxCad	Date: 15-Aug-14	
Material / Matière: 16 Ga Cold Rolled A1008 CS Type B (1.4mm)	Color / Couleur: Light Grey RAL7035	
Description: 6412ESW 800mm x 600mm x 270mm Body		Finish / Fini: Textured
Part Number / Numéro Pièce: <b>6412ESW060830B</b>	Rev.:	6
		9

Qty	Part Number	Rev	Description
1	STK-S-00100	0	3.5" x 2" Silver Milar Flexcon Sticker
1	STK-Q-16080	0	Ground Stud M6 x 16mm Steel
1	STK-P-03820R	0	Powder Paint (Light Grey / Rough Textured)
4	STK-Q-16005	0	Stud M8 x 35mm Steel
1	6412ESW060830B-P	0	6412ESW 800mm x 600mm x 270mm Body Part
Parts List			

This drawing is confidential and must not be reproduced or used without the consent of EXM

Ce dessin est confidentiel et ne doit pas être reproduit ou utilisé sans le consentement de EXM

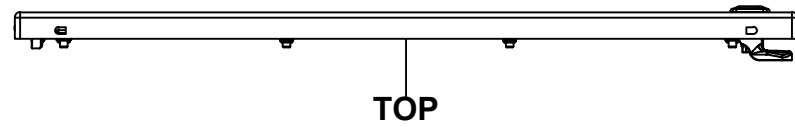

TOP

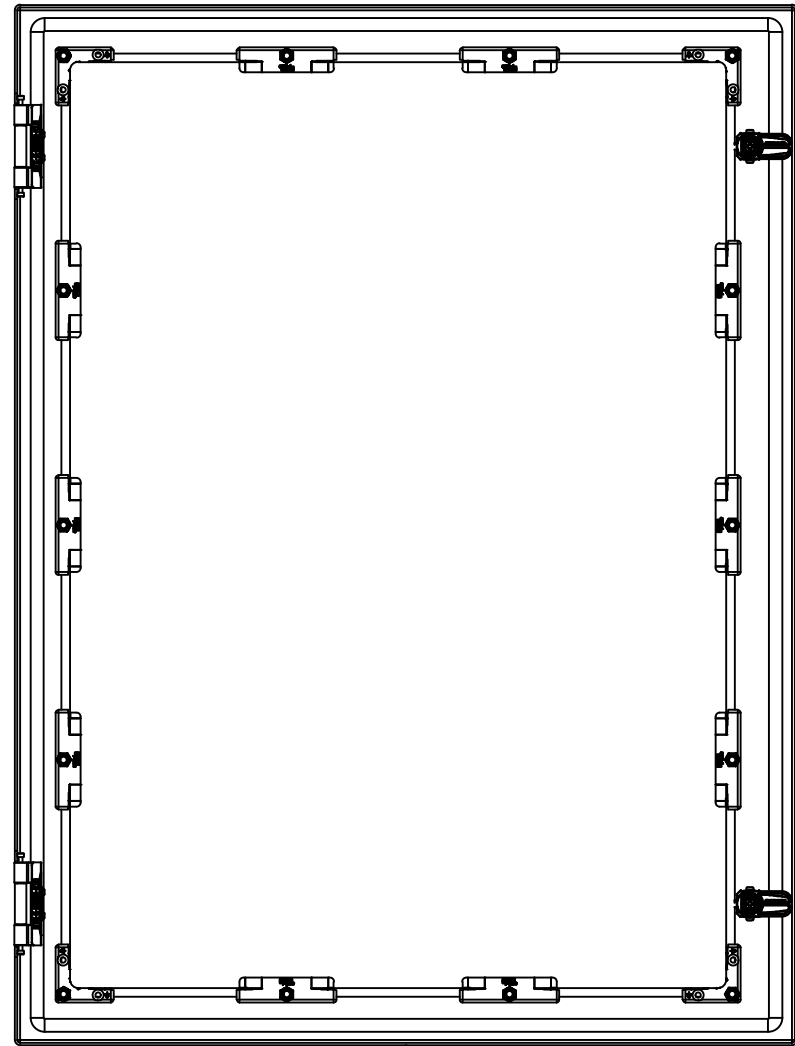

BACK



BOTTOM

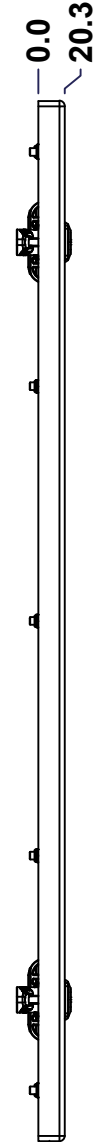

LEFT

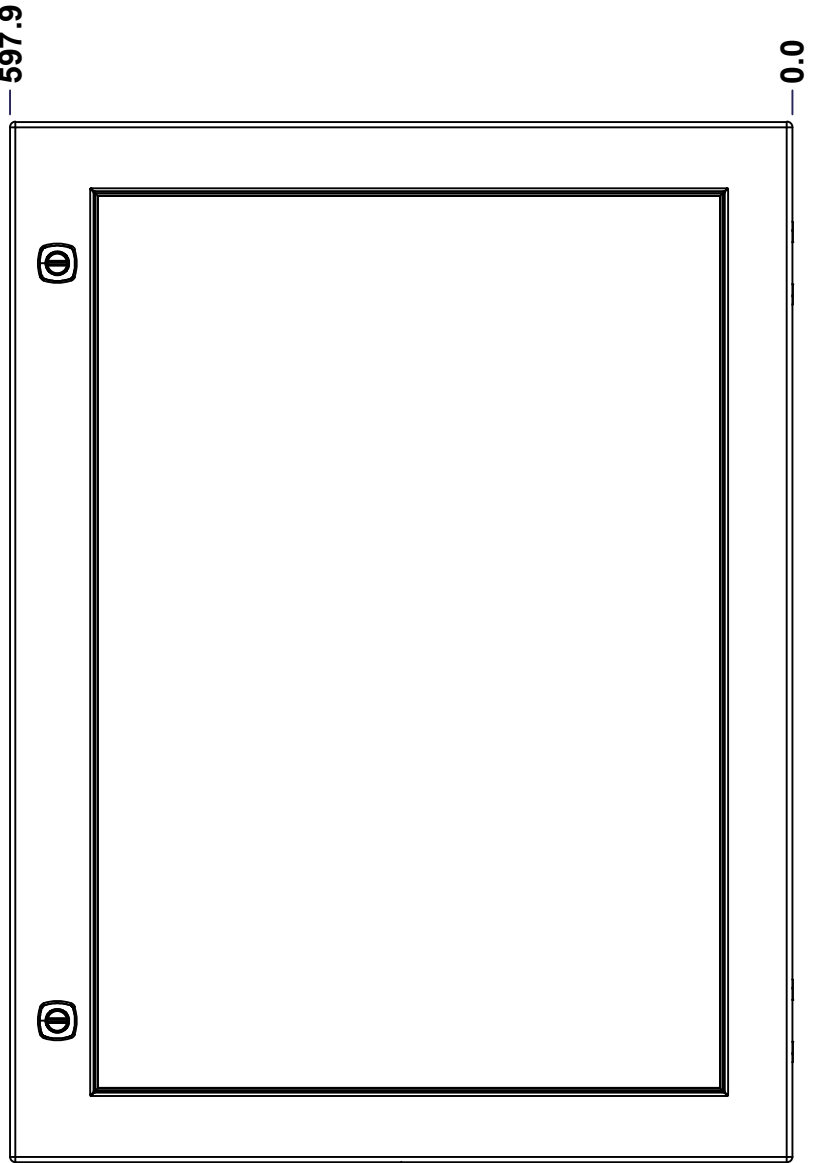

FRONT

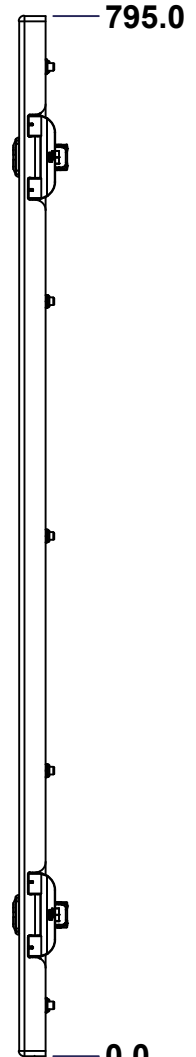

RIGHT

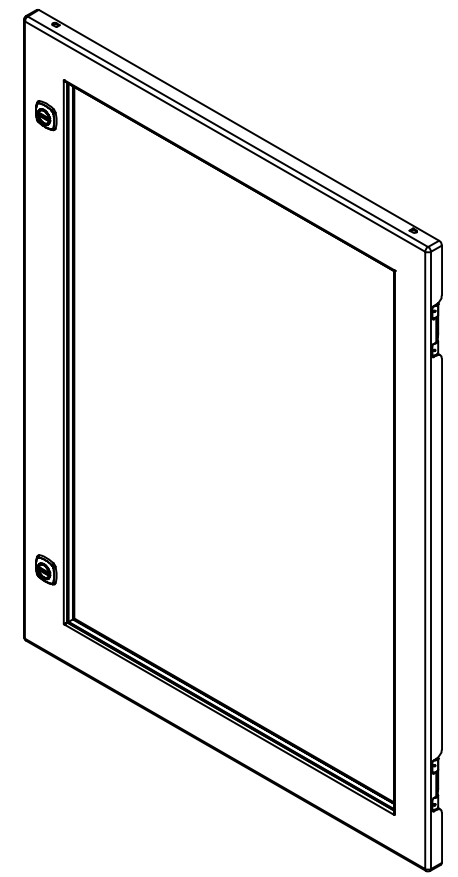

Isometric View

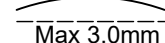
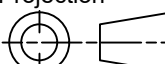

No.	Revisions	Date	By/Par

 Tél: (450) 979-4373 Fax: (450) 979-4626 <a href="http://www.exmweb.com">www.exmweb.com</a>		Flatness Aplatissement  Max 3.0mm Projection 
Customer Client	Date	
Drawn By Dessiné Par	BoxCad: BoxCad	Date 15-Aug-14
Material Matière	14 Ga Cold Rolled A1008 CS Type B (1.7mm)	
Color Couleur	Light Grey RAL7035	Finish Fini Textured
Description		Detail Rev.
6412ESW 800mm x 600mm Cover		
Part Number Numéro Pièce	Rev.	7
6412ESW060830C	0	9

SEE BILL OF MATERIAL ON LAST PAGE

This drawing is confidential and must not be reproduced or used without the consent of EXM

Ce dessin est confidentiel et ne doit pas être reproduit ou utilisé sans le consentement de EXM

**STANDARD FEATURES ARE NOT LISTED IN THIS HOLE TABLE**

**HOLE TABLE - FRONT VIEW (CUSTOM FEATURE ONLY)**

CUT-OUT	XDIM	YDIM	DESCRIPTION
1	37.3	218.1	STUD M6 x 25mm (Inside)
2	548.4	218.1	STUD M6 x 25mm (Inside)
3	37.3	397.5	STUD M6 x 25mm (Inside)
4	548.4	397.5	STUD M6 x 25mm (Inside)
5	37.3	576.9	STUD M6 x 25mm (Inside)
6	548.4	576.9	STUD M6 x 25mm (Inside)
7	37.3	756.2	STUD M6 x 25mm (Inside)
8	37.3	38.8	STUD M6 x 25mm (Inside)
9	207.7	756.2	STUD M6 x 25mm (Inside)
10	207.7	38.8	STUD M6 x 25mm (Inside)
11	378.0	756.2	STUD M6 x 25mm (Inside)
12	378.0	38.8	STUD M6 x 25mm (Inside)
13	548.4	756.2	STUD M6 x 25mm (Inside)
14	548.4	38.8	STUD M6 x 25mm (Inside)
-----			
15	561.7	687.0	LOCK 880 SCQ4-SL @ 180.0°
16	561.7	108.0	LOCK 880 SCQ4-SL @ 180.0°

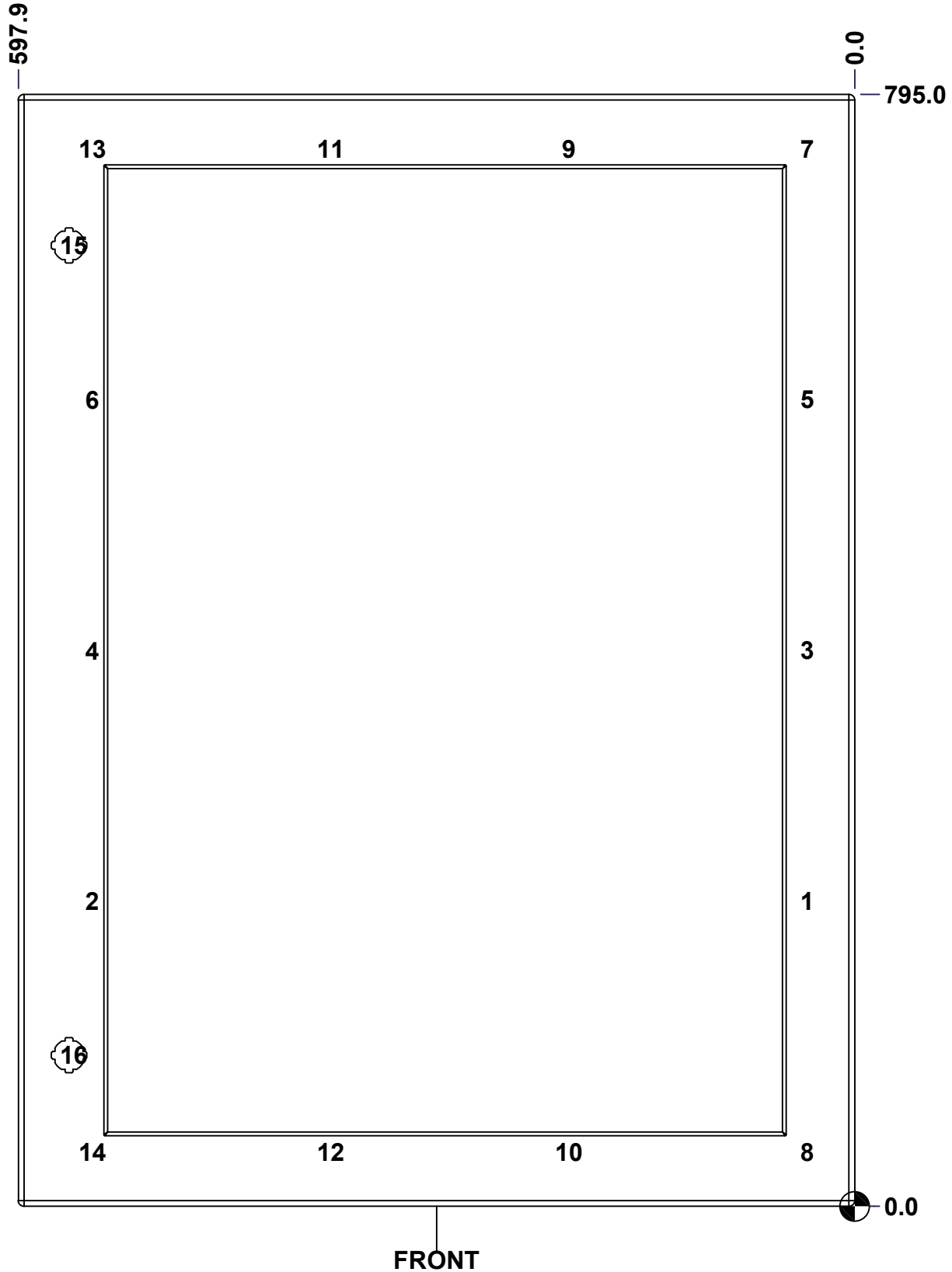

	Description	Status
	6412ESW 800mm x 600mm Cover	(NULL)
Part Number Numéro Pièce <b>6412ESW060830C</b>	Rev.	8
	<b>0</b>	9



This drawing is confidential and must not be reproduced or used without the consent of EXM

Ce dessin est confidentiel et ne doit pas être reproduit ou utilisé sans le consentement de EXM

No.	Revisions	Date	By/Par

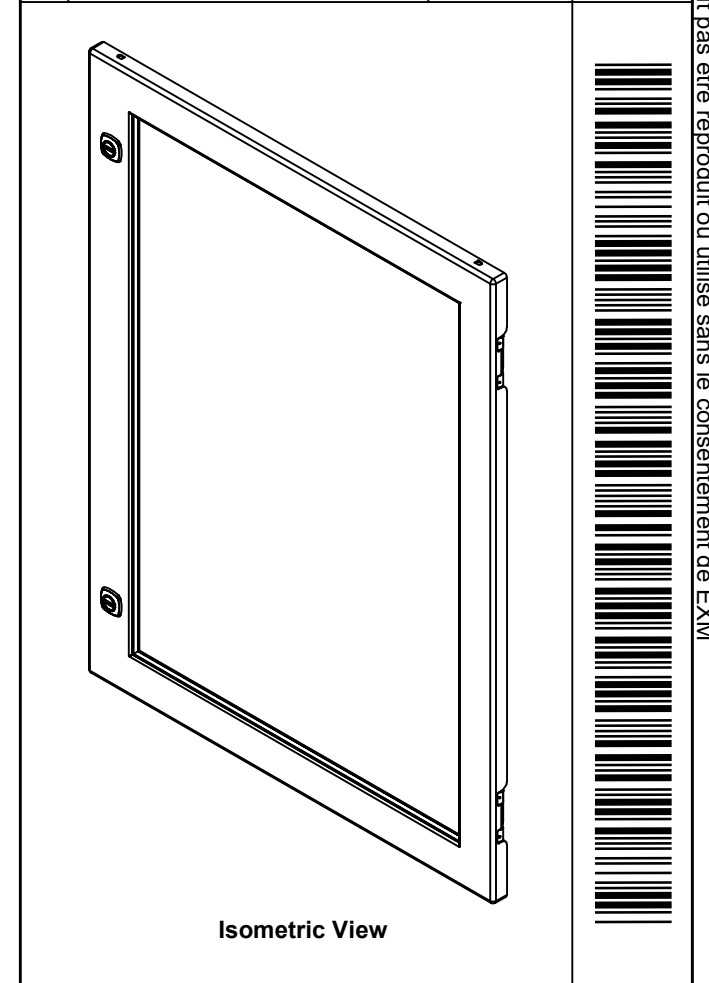

**EXM**  
www.exmweb.com

Tél: (450) 979-4373  
Fax: (450) 979-4626

Flatness  
Aplatissement  
Max 3.0mm

Projection

2	STK-K-12500	19	5412 ES 1/4 Turn Lock
1	STK-P-03820R	0	Powder Paint (Light Grey / Rough Textured)
1	STK-A-60703	0	5412 ESW Lexan Bracket Kit
14	STK-Q-16012	0	Stud M6 x 25mm Steel
1	STK-G-02710	0	880 HWKG - Windows Kit Gasket
1	6412ESW060830LXG	0	6412ESW 800mm x 600mm Lexan Gasket Part
1	6412ESW060830LX	0	6412ESW 707.9mm x 501.6mm Lexan Part
1	6412ESW060830G	0	6412ESW 800mm x 600mm Cover Gasket Part
1	6412ESW060830C-P	0	6412ESW 800mm x 600mm Cover Part
2	STK-K-09800		5412 ES Hinge with 2 Captive Hinge Pins
10	STK-Q-60701	2.1	880 WK - Lexan 1/4" Fixing Bracket
QTY	Part Number	Rev	Description
Parts List			

Customer Client

Drawn By / Dessiné Par: BoxCad: BoxCad

Material / Matière: 14 Ga Cold Rolled A1008 CS Type B (1.7mm)

Color / Couleur: Light Grey RAL7035

Finish / Fini: Textured

Description: 6412ESW 800mm x 600mm Cover

Part Number / Numéro Pièce: **6412ESW060830C**

Date: 15-Aug-14

Detail Rev.:

Rev.	9
<b>0</b>	<b>9</b>

This drawing is confidential and must not be reproduced or used without the consent of EXM

Ce dessin est confidentiel et ne doit pas être reproduit ou utilisé sans le consentement de EXM

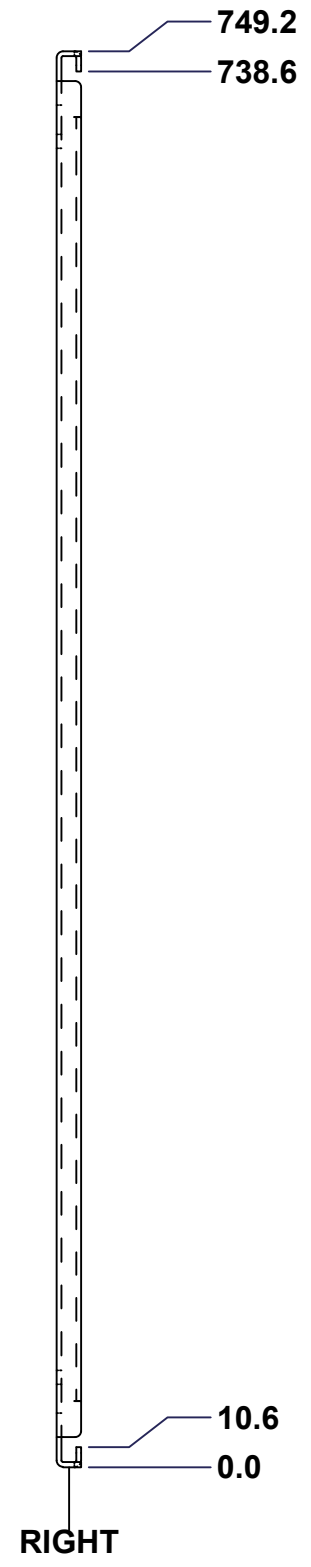
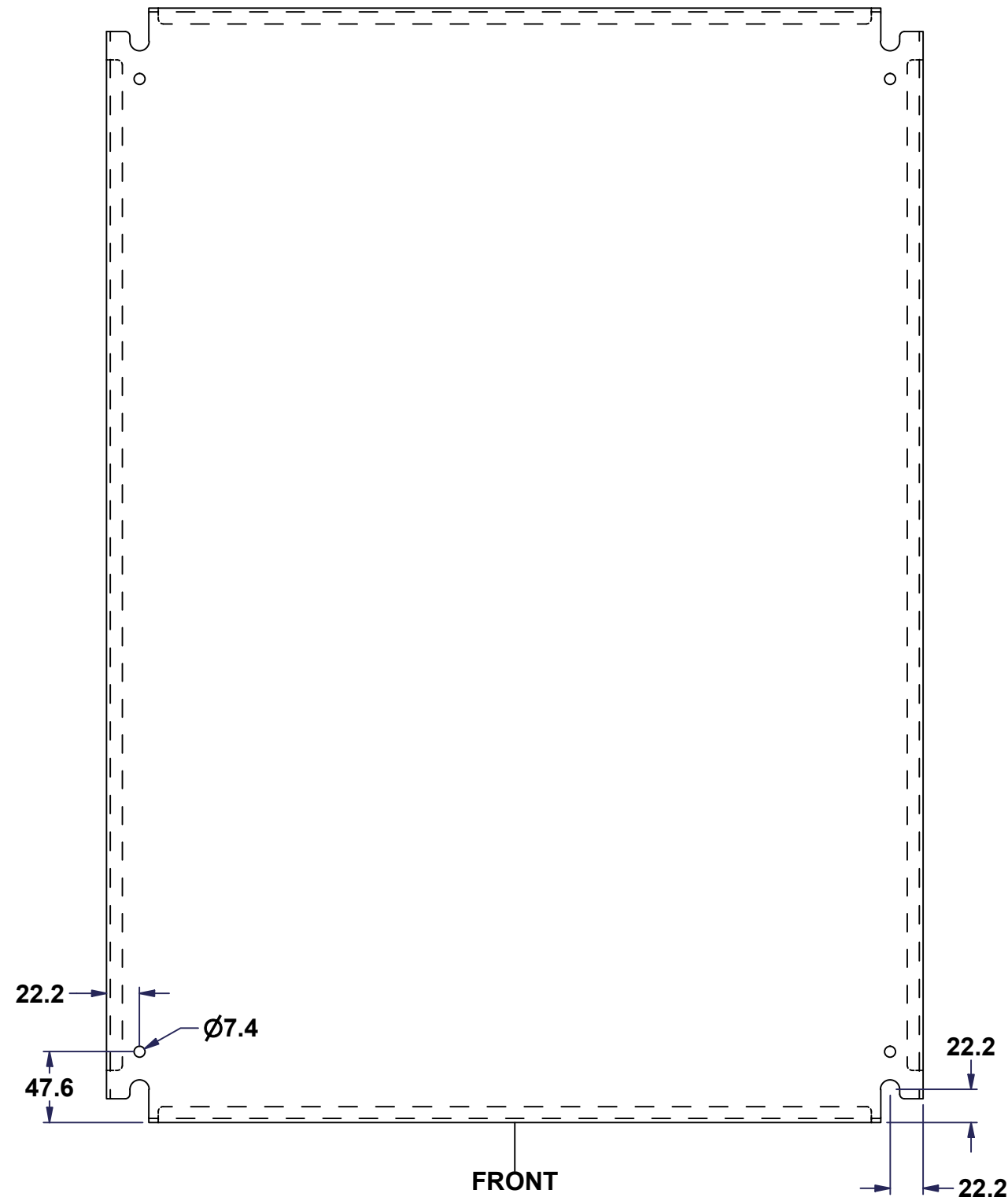
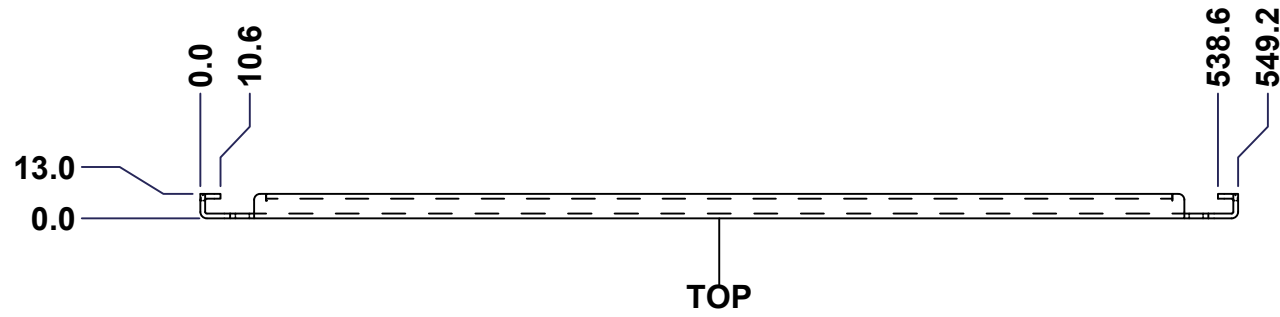

No.	Revisions	Date	By/Par

Isometric View

Tél: (450) 979-4373 Fax: (450) 979-4626 www.exmweb.com		Flatness Aplatissement Max 3.0mm
Projection 		Date 23-Jan-07
Customer Client	Date	
Drawn By Dessiné Par	BoxCad	Date 23-Jan-07
Material Matière	12 Ga Galvanized (2.5mm)	
Color Couleur	Unpainted	Finish Fini Unpainted
Description	Detail Rev.	
886 SP - Inner Panel		
Part Number Numéro Pièce	Rev.	1
<b>886 SP0608ES</b>	<b>0</b>	2

SEE BILL OF MATERIAL ON LAST PAGE

This drawing is confidential and must not be reproduced or used without the consent of EXM

Ce dessin est confidentiel et ne doit pas être reproduit ou utilisé sans le consentement de EXM

No.	Revisions	Date	By/Par

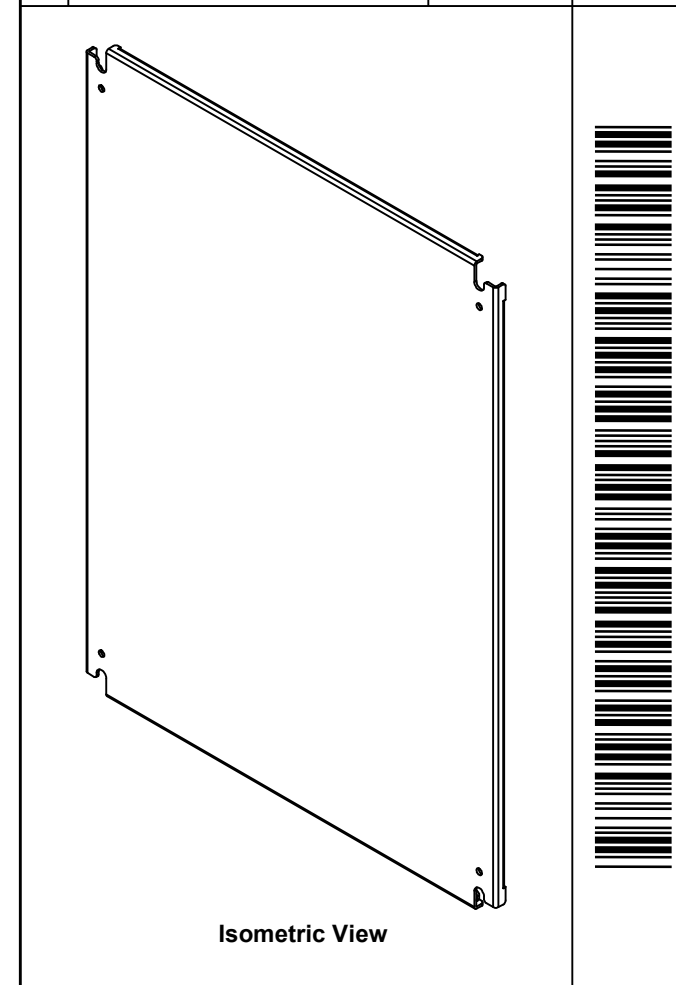

 Tél: (450) 979-4373 Fax: (450) 979-4626 www.exmweb.com	Flatness Aplatissement
	Max 3.0mm
Projection	

Customer Client	Date
-----------------	------

Drawn By Dessiné Par	BoxCad	Date	23-Jan-07
-------------------------	--------	------	-----------

Material Matière	12 Ga Galvanized (2.5mm)
---------------------	--------------------------

Color Couleur	Unpainted	Finish Fini	Unpainted
------------------	-----------	----------------	-----------

Description	Detail Rev.
886 SP - Inner Panel	

Qty	Part Number	Rev	Description
1	886 SP0608ES-P	0	886 SP - Inner Panel Part
Parts List			

Part Number Numéro Pièce	Rev.	2
<b>886 SP0608ES</b>	<b>0</b>	<b>2</b>