

This drawing is confidential and must not be reproduced or used without the consent of EXM

Ce dessin est confidentiel et ne doit pas être reproduit ou utilisé sans le consentement de EXM

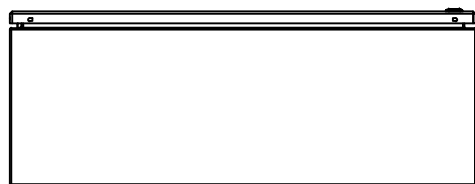

TOP

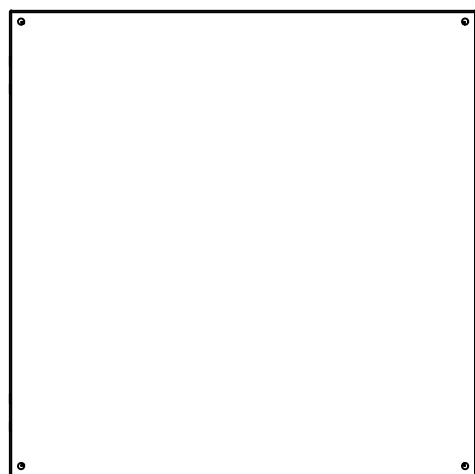

BACK

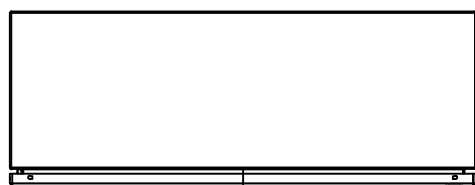

BOTTOM

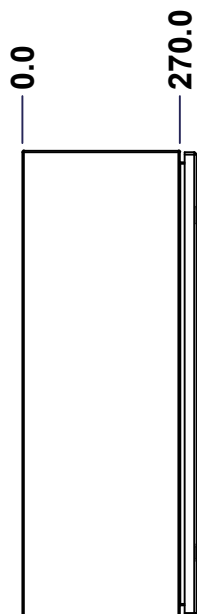

LEFT

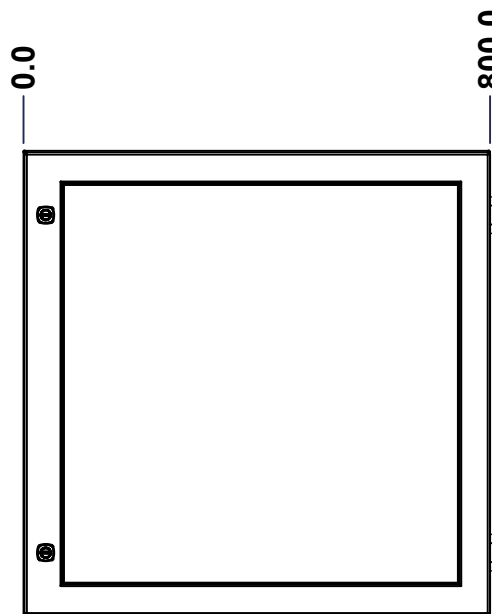

FRONT

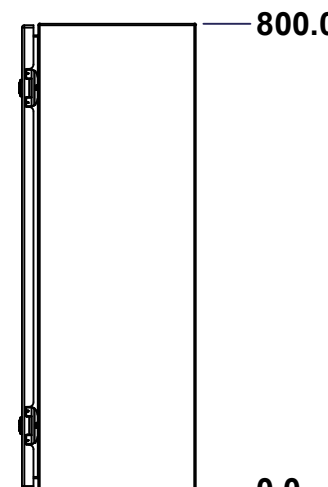

RIGHT

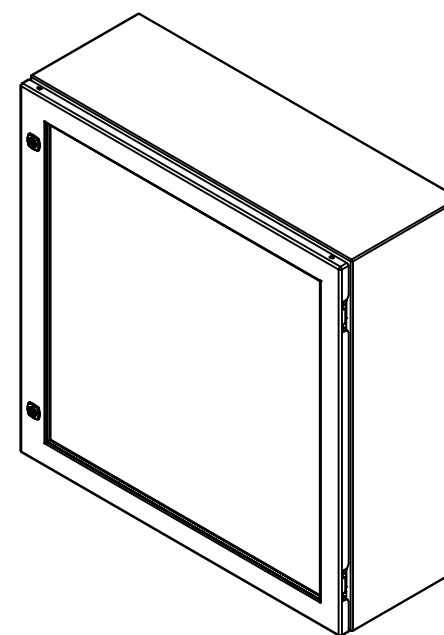

Isometric View

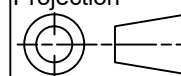

No.	Revisions	Date	By/Par

 Tél: (450) 979-4373 Fax: (450) 979-4626 www.exmweb.com		Flatness Aplatissement Max 3.0mm Projection 
Customer Client	Date	
Drawn By Dessiné Par	BoxCad: BoxCad	Date 15-Aug-14
Material Matière	14 Ga Cold Rolled A1008 CS Type B (1.7mm)	
Color Couleur	Light Grey RAL7035	Finish Fini Textured
Description	Detail Rev.	
6412ESW 800mm x 800mm x 270mm Assembly		
Part Number Numéro Pièce	Rev.	1
6412ESW080830	0	9

SEE BILL OF MATERIAL ON LAST PAGE

This drawing is confidential and must not be reproduced or used without the consent of EXM

Ce dessin est confidentiel et ne doit pas être reproduit ou utilisé sans le consentement de EXM

NOTE	
ITEM	DESCRIPTION
1	NEMA 4, 12 Enclosure (IP66)
2	C/W Standard ground studs on box and cover
3	W/O Standard door stiffener
4	C/W Standard inner panel (Included)
5	C/W Standard inner panel mounting studs

No.	Revisions	Date	By/Par

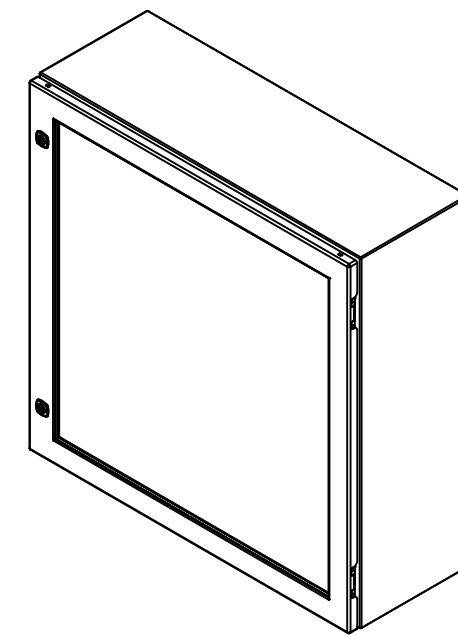

Isometric View



Tél: (450) 979-4373
 Fax: (450) 979-4626
www.exmweb.com

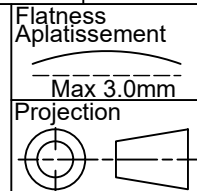

Customer Client	Date
Drawn By / Dessiné Par: BoxCad: BoxCad	Date: 15-Aug-14
Material / Matière: 14 Ga Cold Rolled A1008 CS Type B (1.7mm)	

Color / Couleur: Light Grey RAL7035	Finish / Fini: Textured
Description: 6412ESW 800mm x 800mm x 270mm Assembly	
Part Number / Numéro Pièce: 6412ESW080830	Rev. / Révis: 0
	2 / 9

PACKING		
ITEM	QTY	DESCRIPTION
Cardboard sleeve	2	Top and Bottom
Cardboard strip	2	Between back of enclosure and inner panel
Plastic bag	1	To protect cover surface and inside gasket
Plastic strap - Black	2	To Squeeze the 2 cardboard sleeve together
Packaging label	1	White label with product number

Qty	Part Number	Rev	Description
1	886 SP0808ES	0	886 SP - Inner Panel
2	STK-K-01320	0	5412 ES Inner Panel Accessory Kit
1	STK-K-01800	5	5412 ES Accessory Kit
1	6412ESW080830C	0	6412ESW 800mm x 800mm Cover
1	6412ESW080830B	0	6412ESW 800mm x 800mm x 270mm Body
2	STK-Q-04050-08	0	M6 x 8mm Hexagon Socket Head Machine Screw
Parts List			

This drawing is confidential and must not be reproduced or used without the consent of EXM

Ce dessin est confidentiel et ne doit pas être reproduit ou utilisé sans le consentement de EXM



TOP

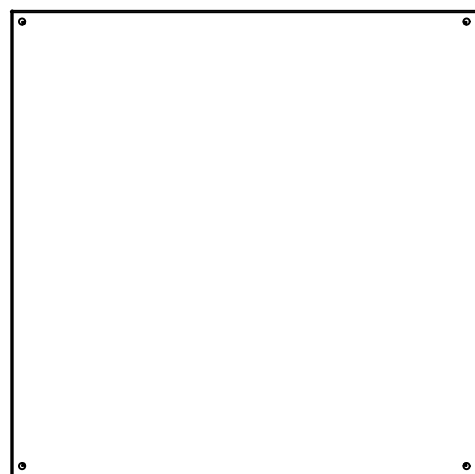

BACK

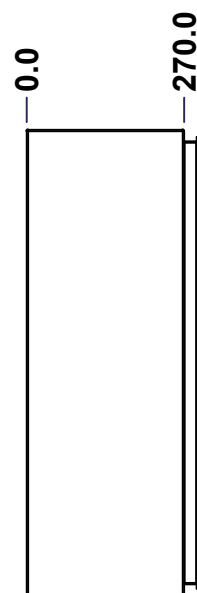

LEFT

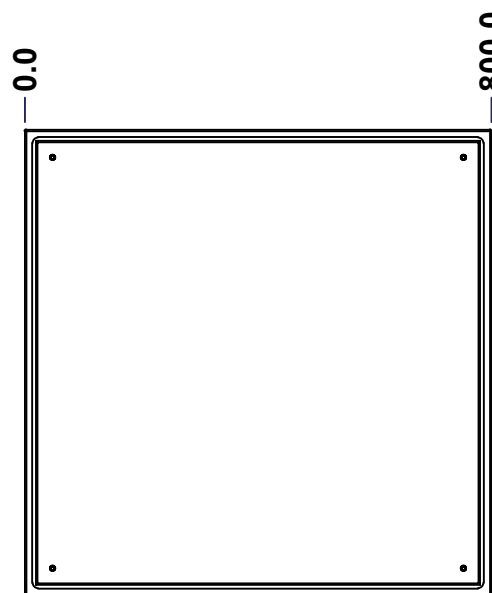

FRONT

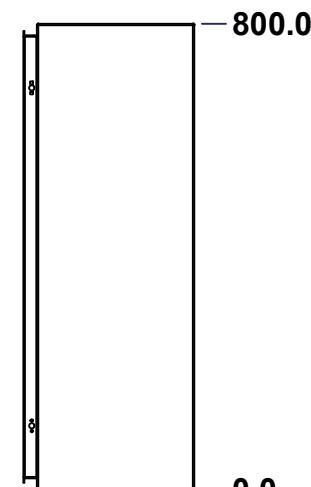

RIGHT

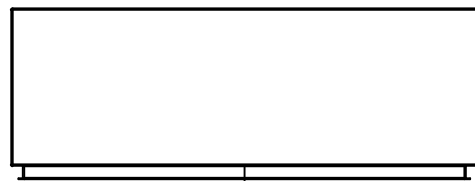

BOTTOM

No.	Revisions	Date	By/Par

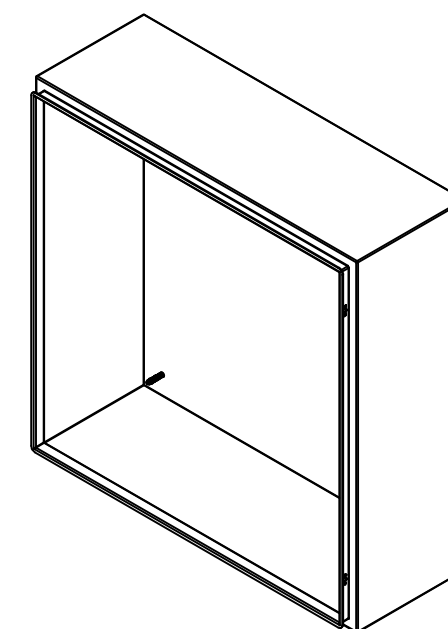

Isometric View



Tél: (450) 979-4373
 Fax: (450) 979-4626
www.exmweb.com

Flatness
Aplatissement

Max 3.0mm

Projection



Customer Client	Date
Drawn By / Dessiné Par: BoxCad: BoxCad	Date: 15-Aug-14
Material / Matière: 14 Ga Cold Rolled A1008 CS Type B (1.7mm)	
Color / Couleur: Light Grey RAL7035	Finish / Fini: Textured
Description: 6412ESW 800mm x 800mm x 270mm Body	
Detail Rev.	
Part Number / Numéro Pièce: 6412ESW080830B	Rev. 3
	9

SEE BILL OF MATERIAL ON LAST PAGE

This drawing is confidential and must not be reproduced or used without the consent of EXM

Ce dessin est confidentiel et ne doit pas être reproduit ou utilisé sans le consentement de EXM

STANDARD FEATURES ARE NOT LISTED IN THIS HOLE TABLE			
HOLE TABLE - RIGHT VIEW (CUSTOM FEATURE ONLY)			
CUT-OUT	XDIM	YDIM	DESCRIPTION
1	231.9	50.8	GND STUD M6 x 16mm (Inside)
2	219.2	749.2	LABEL_EXM (Inside)

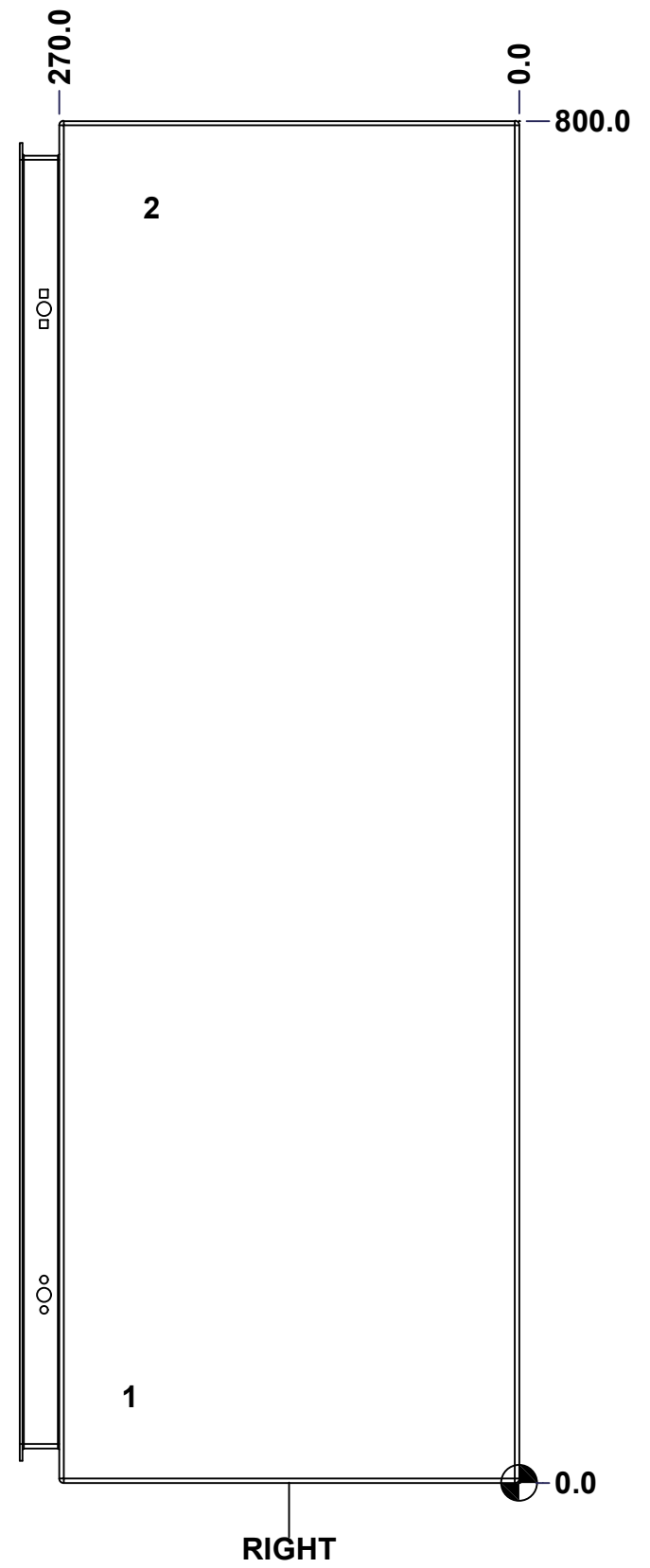

	Description 6412ESW 800mm x 800mm x 270mm Body		Status (NULL)
	Part Number Numéro Pièce 6412ESW080830B		Rev. 4 0 / 9

This drawing is confidential and must not be reproduced or used without the consent of EXM

Ce dessin est confidentiel et ne doit pas être reproduit ou utilisé sans le consentement de EXM

STANDARD FEATURES ARE NOT LISTED IN THIS HOLE TABLE

HOLE TABLE - BACK VIEW (CUSTOM FEATURE ONLY)

CUT-OUT	XDIM	YDIM	DESCRIPTION
1	47.6	47.6	IP STUD M8 x 35mm (Inside)
2	47.6	752.4	IP STUD M8 x 35mm (Inside)
3	752.4	752.4	IP STUD M8 x 35mm (Inside)
4	752.4	47.6	IP STUD M8 x 35mm (Inside)

5	781.0	19.1	RND Ø9.9
6	781.0	781.0	RND Ø9.9
7	19.1	781.0	RND Ø9.9
8	19.1	19.1	RND Ø9.9

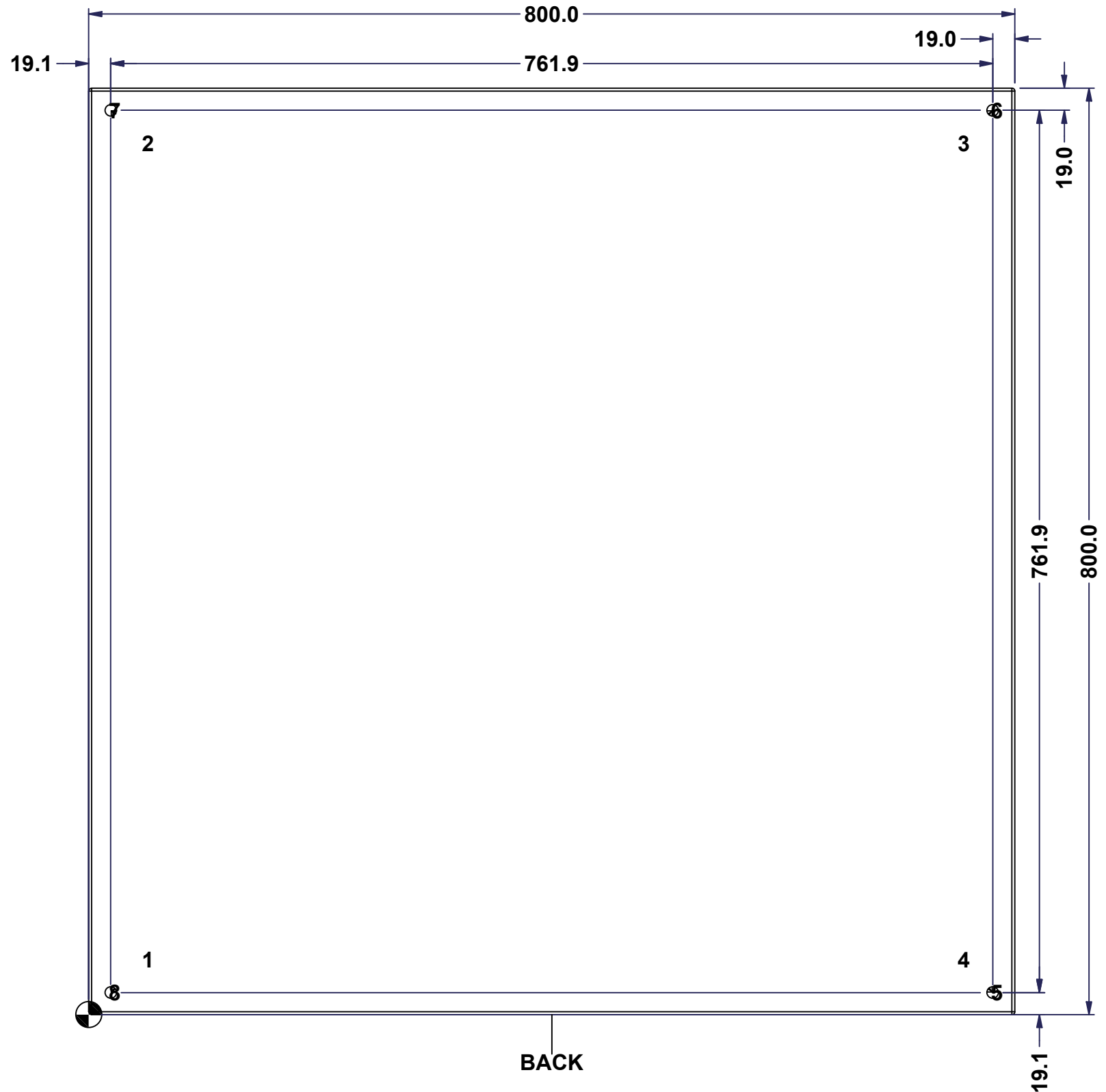

	Description 6412ESW 800mm x 800mm x 270mm Body	Status (NULL)
	Part Number Numéro Pièce 6412ESW080830B	Rev. 5 0 / 9

This drawing is confidential and must not be reproduced or used without the consent of EXM

Ce dessin est confidentiel et ne doit pas être reproduit ou utilisé sans le consentement de EXM

No.	Revisions	Date	By/Par

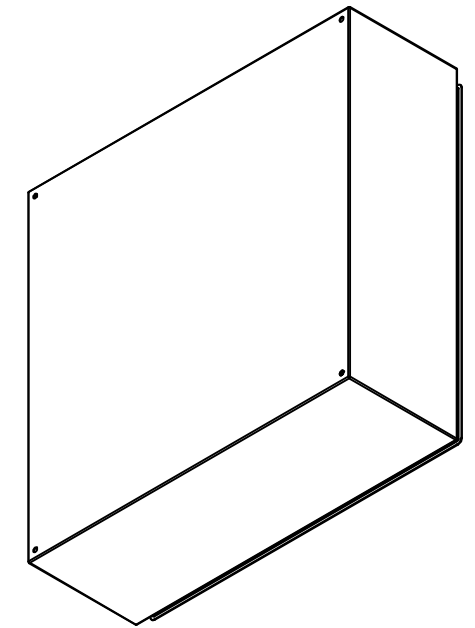

Isometric View

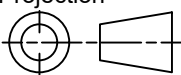

 Tél: (450) 979-4373 Fax: (450) 979-4626 www.exmweb.com	Flatness Aplatissement	Max 3.0mm
	Projection	
Customer Client	Date	
Drawn By Dessiné Par	BoxCad: BoxCad	Date 15-Aug-14
Material Matière	14 Ga Cold Rolled A1008 CS Type B (1.7mm)	
Color Couleur	Light Grey RAL7035	Finish Fini Textured
Description	Detail Rev.	
6412ESW 800mm x 800mm x 270mm Body		
Part Number Numéro Pièce	Rev.	6
6412ESW080830B	0	9

Qty	Part Number	Rev	Description
1	STK-S-00100	0	3.5" x 2" Silver Milar Flexcon Sticker
1	STK-Q-16080	0	Ground Stud M6 x 16mm Steel
1	STK-P-03820R	0	Powder Paint (Light Grey / Rough Textured)
4	STK-Q-16005	0	Stud M8 x 35mm Steel
1	6412ESW080830B-P	0	6412ESW 800mm x 800mm x 270mm Body Part
Parts List			

This drawing is confidential and must not be reproduced or used without the consent of EXM

Ce dessin est confidentiel et ne doit pas être reproduit ou utilisé sans le consentement de EXM

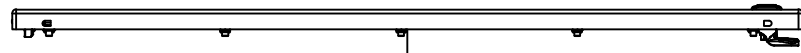

TOP

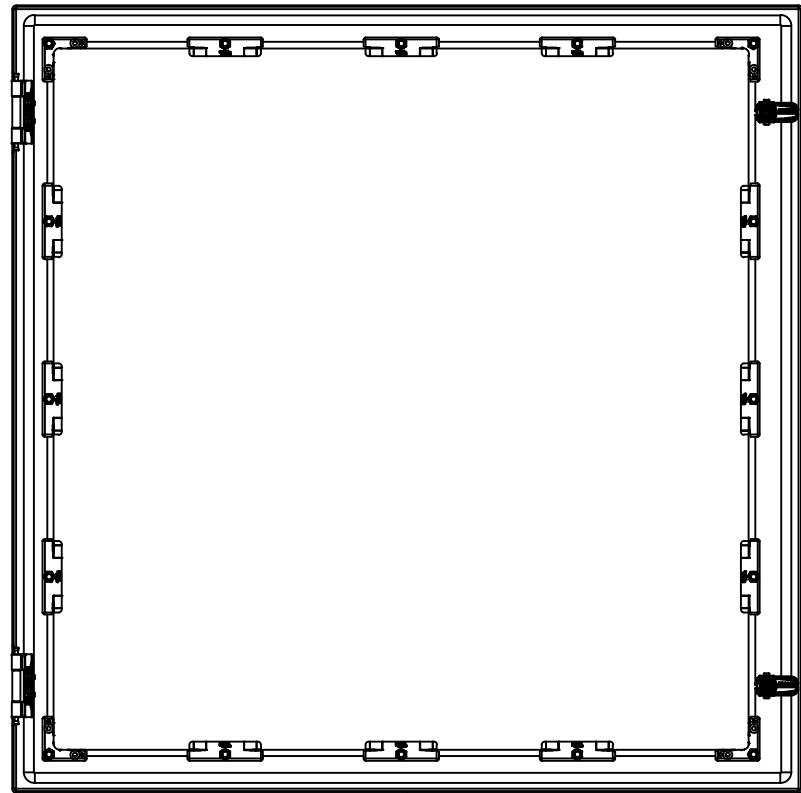

BACK

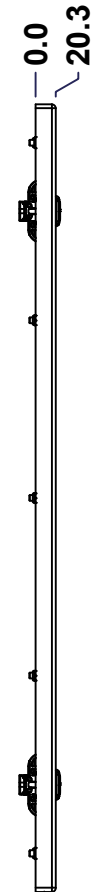

LEFT

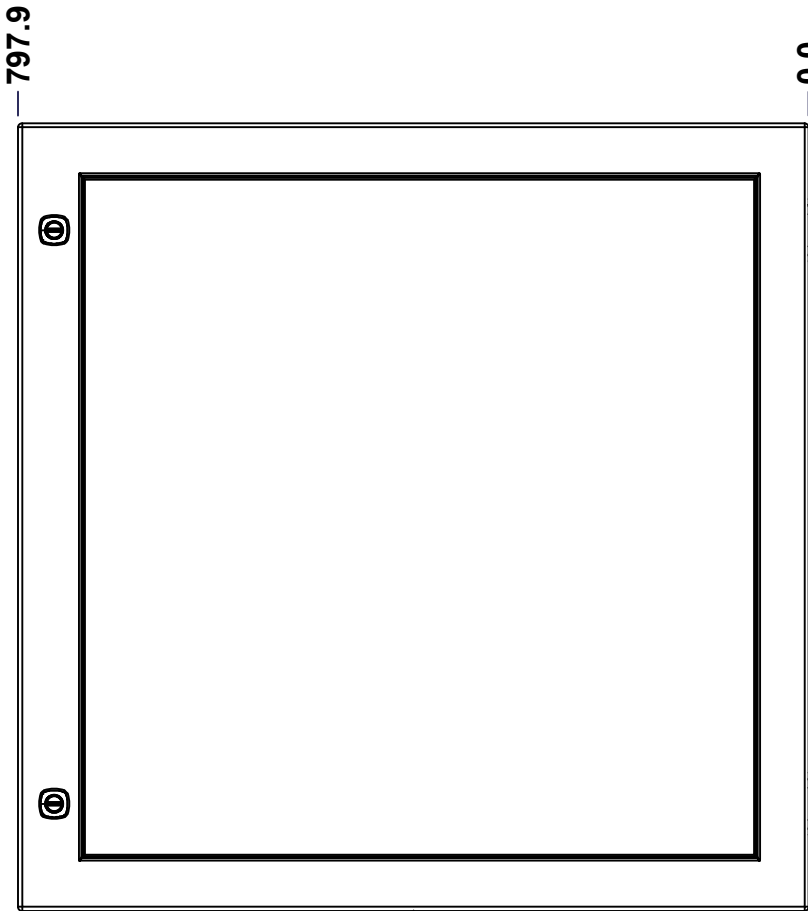

FRONT

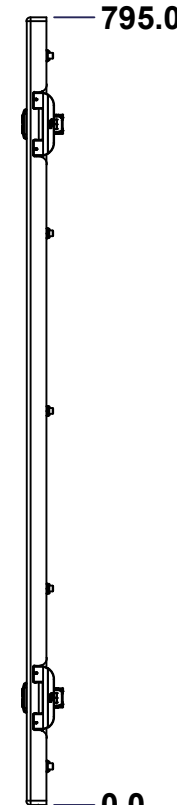

RIGHT

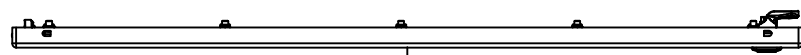

BOTTOM

No.	Revisions	Date	By/Par

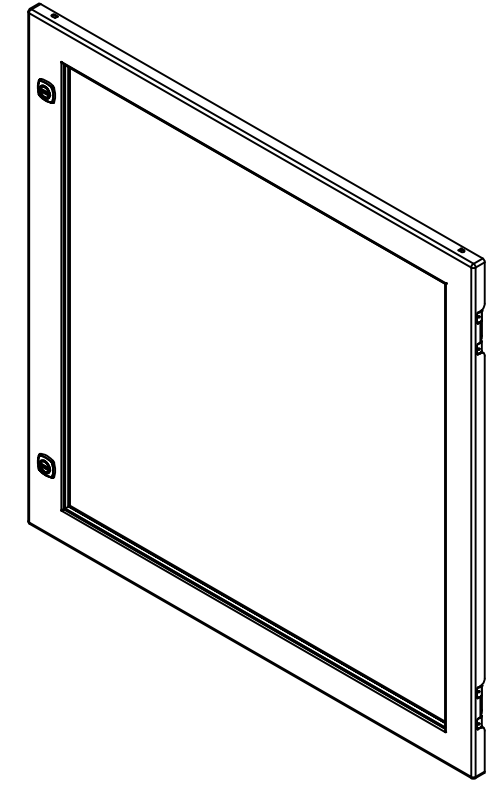

Isometric View



Tél: (450) 979-4373
 Fax: (450) 979-4626
www.exmweb.com

Flatness
 Aplatissement
 Max 3.0mm
 Projection

Customer Client	Date
Drawn By Dessiné Par BoxCad: BoxCad	Date 15-Aug-14
Material Matière 14 Ga Cold Rolled A1008 CS Type B (1.7mm)	
Color Couleur Light Grey RAL7035	Finish Fini Textured
Description 6412ESW 800mm x 800mm Cover	Detail Rev.
Part Number Numéro Pièce 6412ESW080830C	Rev. 0

SEE BILL OF MATERIAL ON LAST PAGE

This drawing is confidential and must not be reproduced or used without the consent of EXM

Ce dessin est confidentiel et ne doit pas être reproduit ou utilisé sans le consentement de EXM

STANDARD FEATURES ARE NOT LISTED IN THIS HOLE TABLE			
HOLE TABLE - FRONT VIEW (CUSTOM FEATURE ONLY)			
CUT-OUT	XDIM	YDIM	DESCRIPTION
1	37.3	218.1	STUD M6 x 25mm (Inside)
2	748.4	218.1	STUD M6 x 25mm (Inside)
3	37.3	397.5	STUD M6 x 25mm (Inside)
4	748.4	397.5	STUD M6 x 25mm (Inside)
5	37.3	576.9	STUD M6 x 25mm (Inside)
6	748.4	576.9	STUD M6 x 25mm (Inside)
7	37.3	756.2	STUD M6 x 25mm (Inside)
8	37.3	38.8	STUD M6 x 25mm (Inside)
9	215.1	756.2	STUD M6 x 25mm (Inside)
10	215.1	38.8	STUD M6 x 25mm (Inside)
11	392.8	756.2	STUD M6 x 25mm (Inside)
12	392.8	38.8	STUD M6 x 25mm (Inside)
13	570.6	756.2	STUD M6 x 25mm (Inside)
14	570.6	38.8	STUD M6 x 25mm (Inside)
15	748.4	756.2	STUD M6 x 25mm (Inside)
16	748.4	38.8	STUD M6 x 25mm (Inside)

17	761.7	687.0	LOCK 880 SCQ4-SL @ 180.0°
18	761.7	108.0	LOCK 880 SCQ4-SL @ 180.0°

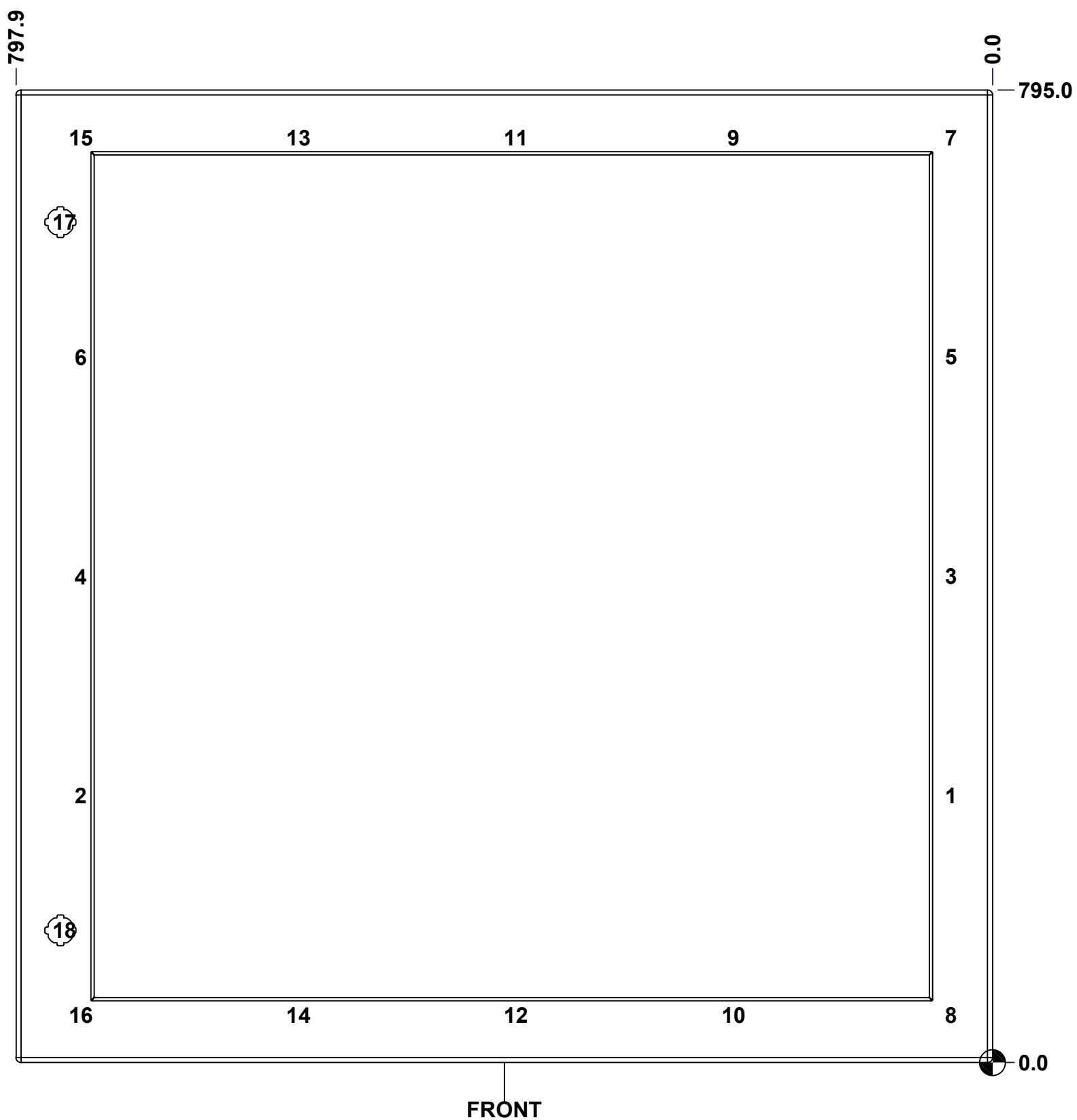

	Description	Status
	6412ESW 800mm x 800mm Cover	(NULL)
	Part Number Numéro Pièce	Rev.
	6412ESW080830C	0
		8
		9

This drawing is confidential and must not be reproduced or used without the consent of EXM

Ce dessin est confidentiel et ne doit pas être reproduit ou utilisé sans le consentement de EXM

No.	Revisions	Date	By/Par

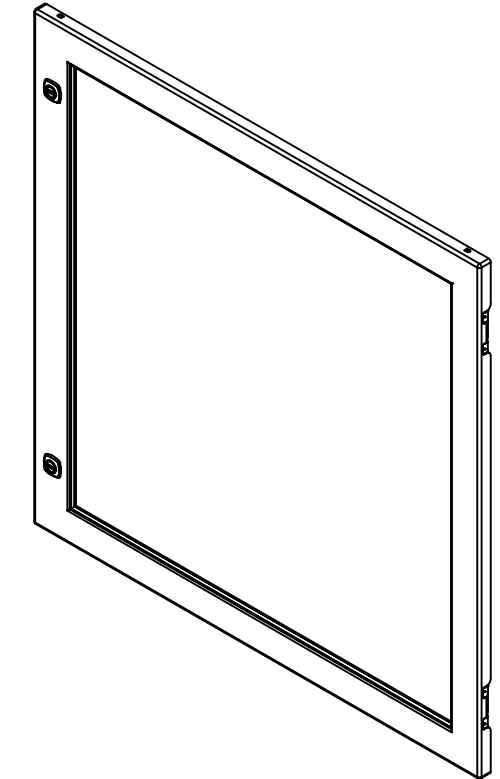

Isometric View



Tél: (450) 979-4373
 Fax: (450) 979-4626
www.exmweb.com

Flatness
Aplatissement
Max 3.0mm
Projection

2	STK-K-12500	19	5412 ES 1/4 Turn Lock
1	STK-P-03820R	0	Powder Paint (Light Grey / Rough Textured)
1	STK-A-60703	0	5412 ESW Lexan Bracket Kit
16	STK-Q-16012	0	Stud M6 x 25mm Steel
1	STK-G-02710	0	880 HWKG - Windows Kit Gasket
1	6412ESW080830LXG	0	6412ESW 800mm x 800mm Lexan Gasket Part
1	6412ESW080830LX	0	6412ESW 707.9mm x 701.6mm Lexan Part
1	6412ESW080830G	0	6412ESW 800mm x 800mm Cover Gasket Part
1	6412ESW080830C-P	0	6412ESW 800mm x 800mm Cover Part
2	STK-K-09800		5412 ES Hinge with 2 Captive Hinge Pins
12	STK-Q-60701	2.1	880 WK - Lexan 1/4" Fixing Bracket

Customer Client	Date
Drawn By Dessiné Par BoxCad: BoxCad	Date 15-Aug-14
Material Matière 14 Ga Cold Rolled A1008 CS Type B (1.7mm)	
Color Couleur Light Grey RAL7035	Finish Fini Textured
Description 6412ESW 800mm x 800mm Cover	Detail Rev.
Part Number Numéro Pièce 6412ESW080830C	Rev. 0

QTY	Part Number	Rev	Description
Parts List			

9
9

This drawing is confidential and must not be reproduced or used without the consent of EXM

Ce dessin est confidentiel et ne doit pas être reproduit ou utilisé sans le consentement de EXM

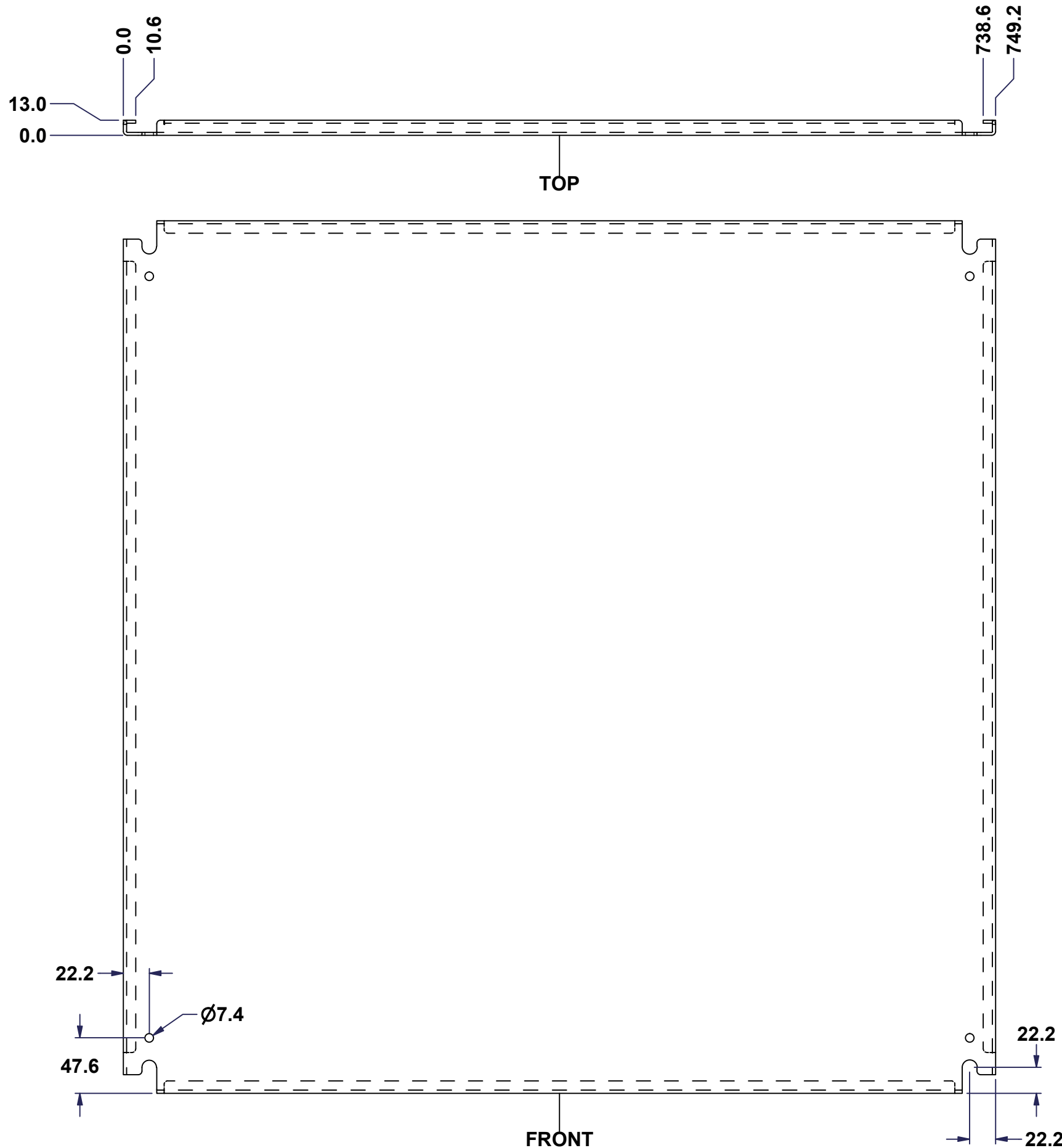

SEE BILL OF MATERIAL ON LAST PAGE

No.	Revisions	Date	By/Par

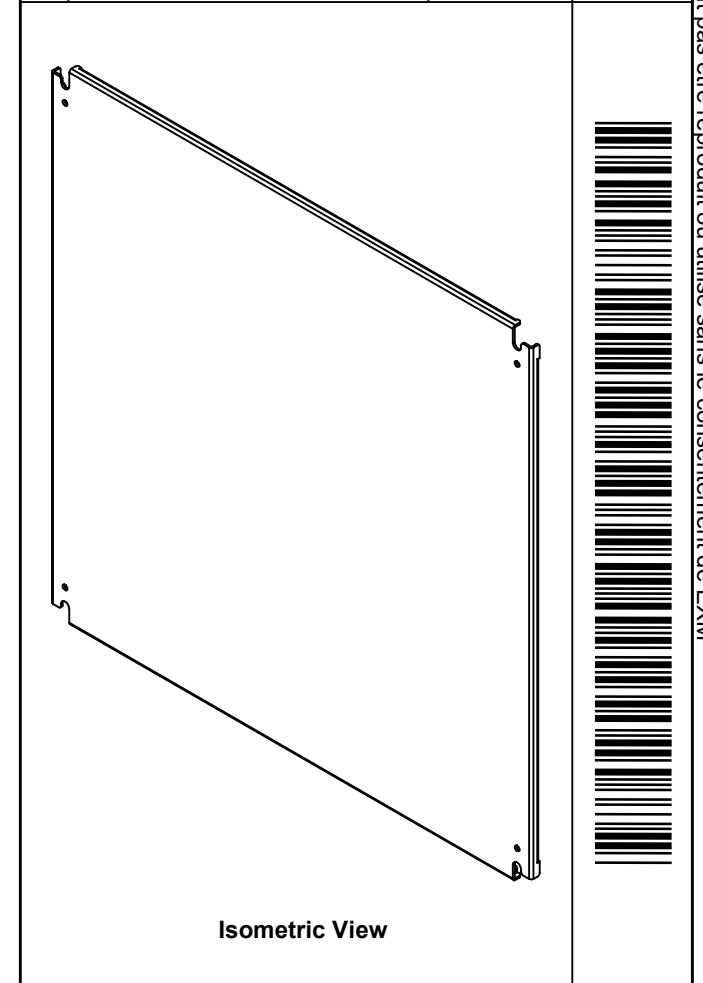

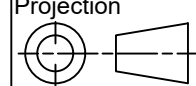
 Tél: (450) 979-4373 Fax: (450) 979-4626 www.exmweb.com		Flatness Aplatissement Max 3.0mm
Projection 		Customer Client Date
Drawn By Dessiné Par BoxCad		Date 23-Jan-07
Material Matière 12 Ga Galvanized (2.5mm)		
Color Couleur Unpainted	Finish Fini Unpainted	
Description 886 SP - Inner Panel		Detail Rev.
Part Number Numéro Pièce 886 SP0808ES		Rev. 1 0

2

This drawing is confidential and must not be reproduced or used without the consent of EXM

Ce dessin est confidentiel et ne doit pas être reproduit ou utilisé sans le consentement de EXM

No.	Revisions	Date	By/Par

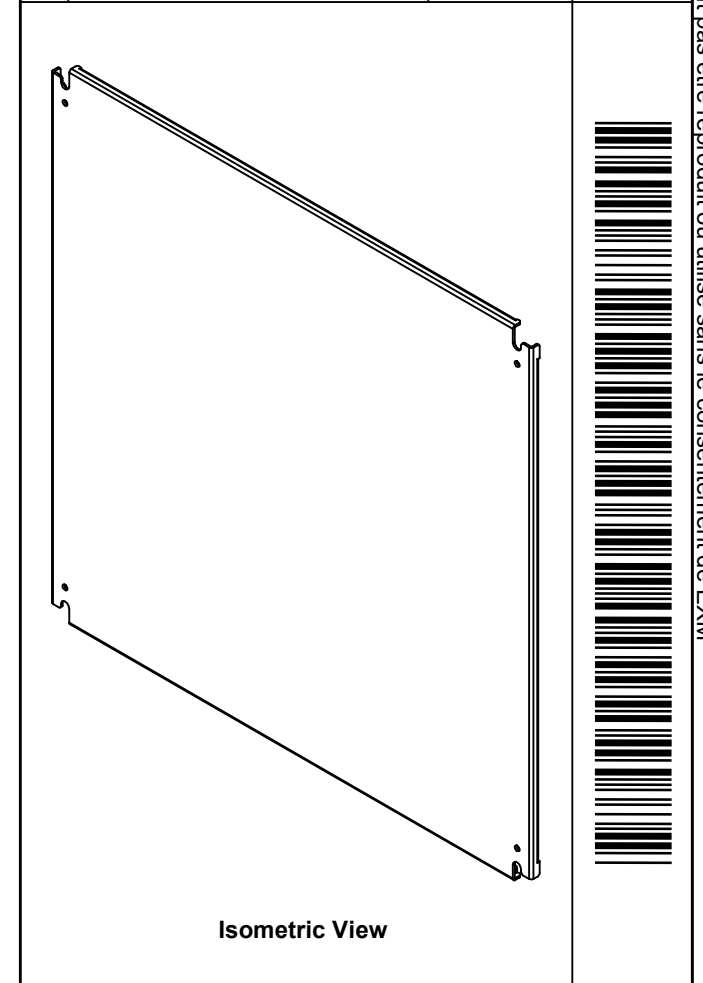

 Tél: (450) 979-4373 Fax: (450) 979-4626 www.exmweb.com		Flatness Aplatissement Max 3.0mm
Customer Client		Date
Drawn By / Dessiné Par: BoxCad		Date: 23-Jan-07
Material / Matière: 12 Ga Galvanized (2.5mm)		
Color / Couleur: Unpainted	Finish / Fini: Unpainted	
Description: 886 SP - Inner Panel		Detail Rev.
Part Number / Numéro Pièce: 886 SP0808ES		Rev. 0 / 2

Qty	Part Number	Rev	Description
1	886 SP0808ES-P	0	886 SP - Inner Panel Part
Parts List			