

This drawing is confidential and must not be reproduced or used without the consent of EXM

Ce dessin est confidentiel et ne doit pas être reproduit ou utilisé sans le consentement de EXM

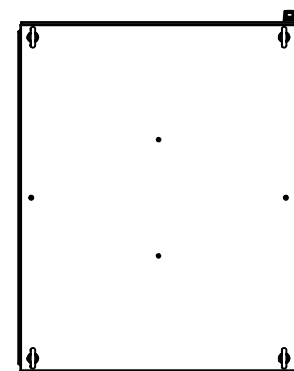

TOP

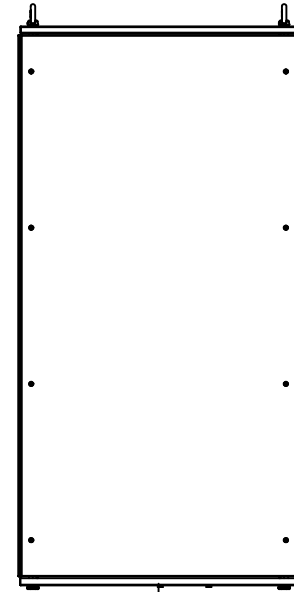

BACK

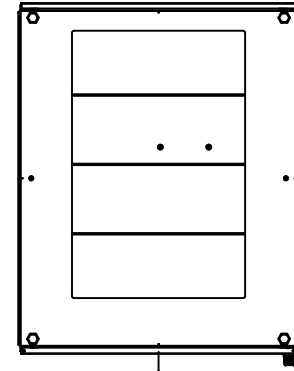

BOTTOM

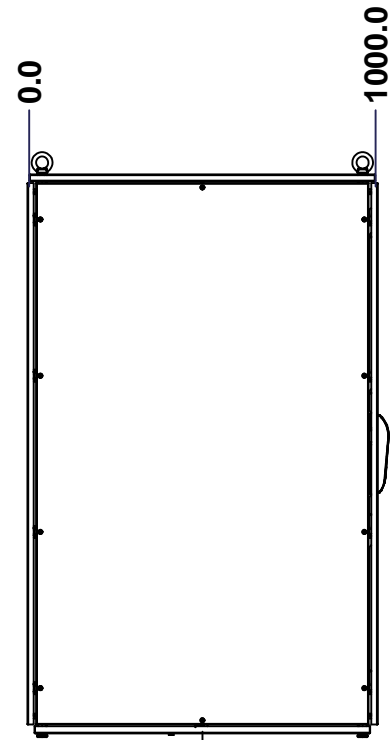

LEFT

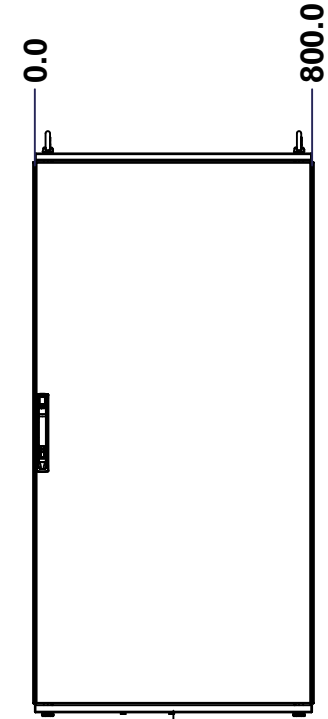

FRONT

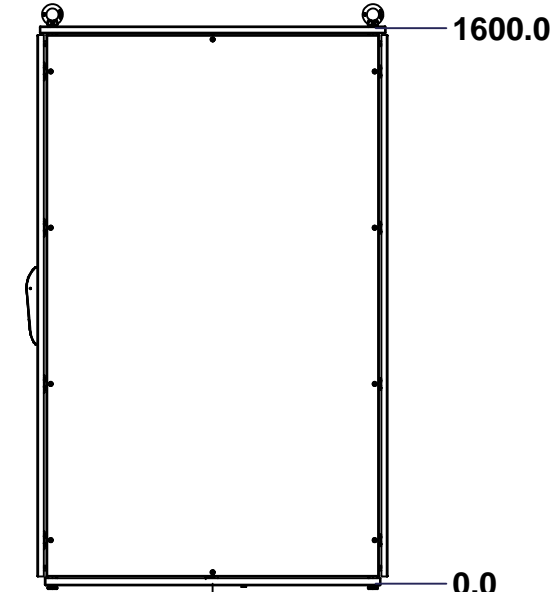

RIGHT

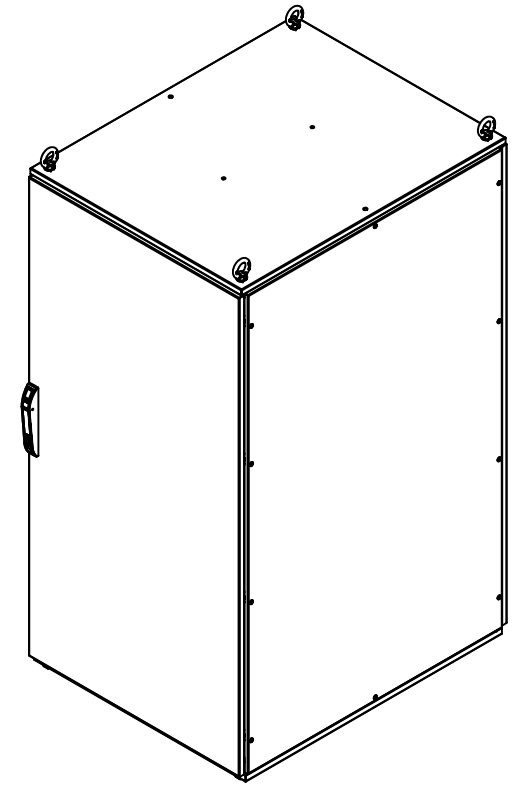

Isometric View

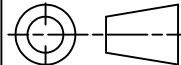

No.	Revisions	Date	By/Par

 Tél: (450) 979-4373 Fax: (450) 979-4626 www.exmweb.com		Flatness Aplatissement Max 3.0mm Projection 
Customer Client	Date	Date
Drawn By Dessiné Par	BoxCad: Annie	Date 04/02/2015
Material Matière	See Part List	
Color Couleur	See Part List	Finish Fini See Part List
Description 6500MX 1600mm x 800mm x 1000mm Assembly	Detail Rev.	
Part Number Numéro Pièce	Rev. 0	1 2

SEE BILL OF MATERIAL ON LAST PAGE

6500MXK160810

This drawing is confidential and must not be reproduced or used without the consent of EXM

Ce dessin est confidentiel et ne doit pas être reproduit ou utilisé sans le consentement de EXM

No.	Revisions	Date	By/Par

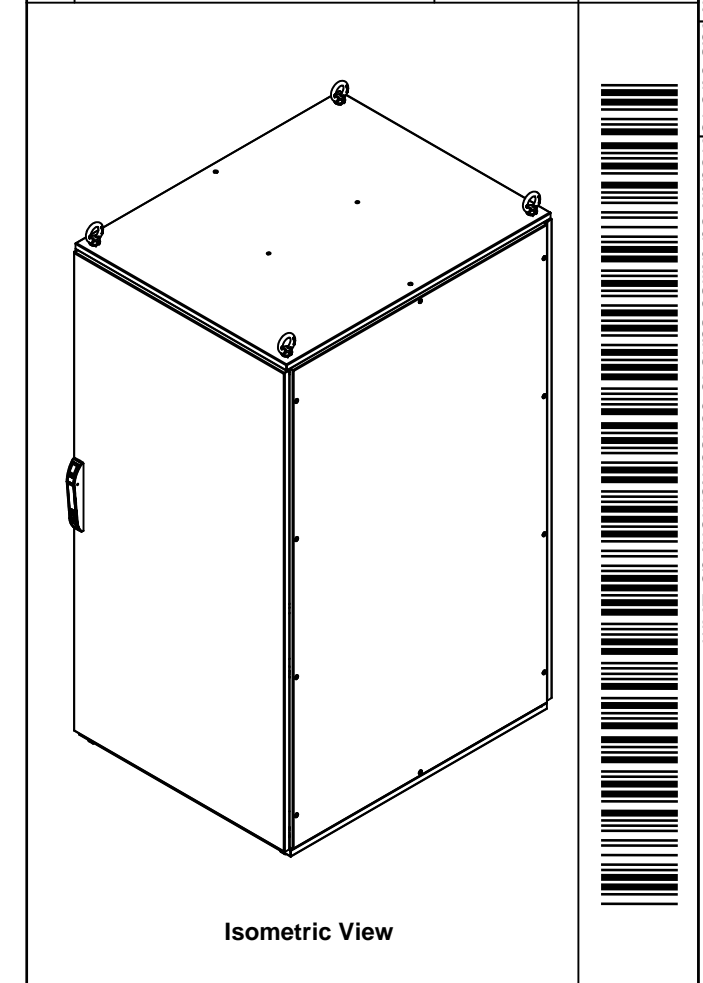

Tél: (450) 979-4373 Fax: (450) 979-4626 www.exmweb.com		Flatness Aplatissement
		Max 3.0mm
Projection		Date
Customer Client		Date 04/02/2015
Drawn By / Dessiné Par: Annie BoxCad: Annie		
Material / Matière		See Part List
Color / Couleur	See Part List	Finish / Fini: See Part List
Description		Detail Rev.
6500MX 1600mm x 800mm x 1000mm Assembly		
Part Number / Numéro Pièce		Rev. 2
6500MXK160810		0

Qty	Part Number	Rev	Description
1	6500MXK160810BIP	0	6500 MXM 1600mm x 800mm Back Inner Panel
1	6500MXK160810R	0	6500 MXC 1600mm x 1000mm Right
1	6500MXK160810L	0	6500 MXC 1600mm x 1000mm Left
1	6500MXK160810F	0	6500 MXD 1600mm x 800mm Front
1	6500MXK160810B	0	6500 MXR 1600mm x 800mm Back
1	6500MXK160810BT	0	6500 MXB 800mm x 1000mm Bottom
1	6500MXK160810T	0	6500 MXT 800mm x 1000mm Top
1	6500MXK160810FR	0	6500 MX 1600mm x 800mm x 1000mm Frame
Parts List			

This drawing is confidential and must not be reproduced or used without the consent of EXM

Ce dessin est confidentiel et ne doit pas être reproduit ou utilisé sans le consentement de EXM

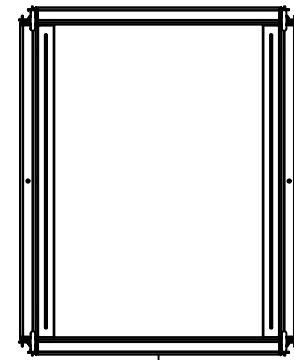

TOP

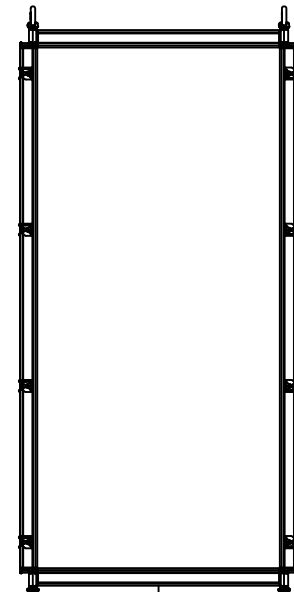

BACK

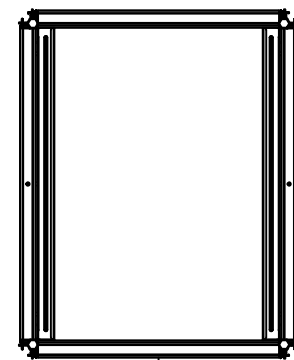

BOTTOM

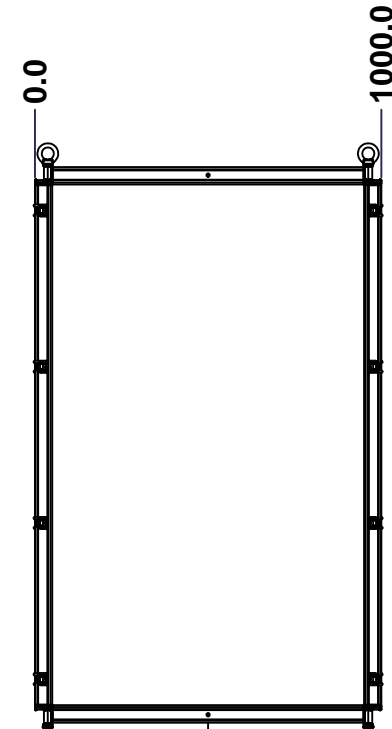

LEFT

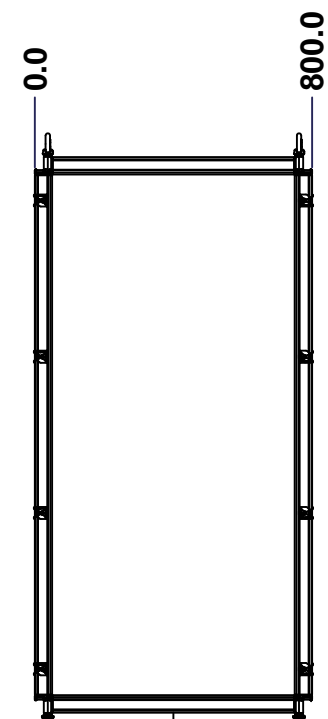

FRONT

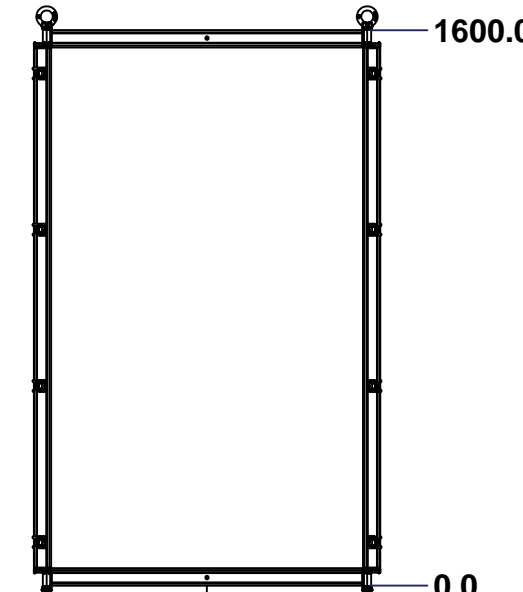

RIGHT

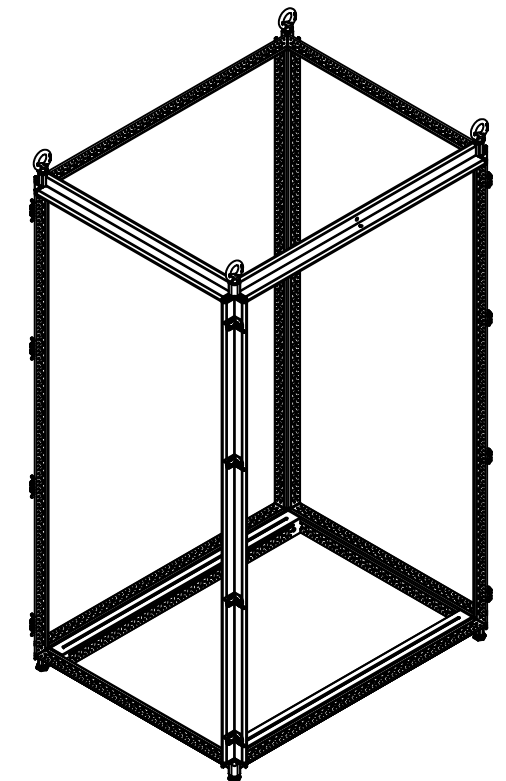

Isometric View

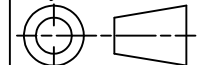

No.	Revisions	Date	By/Par

 Tél: (450) 979-4373 Fax: (450) 979-4626 www.exmweb.com		Flatness Aplatissement Max 3.0mm Projection 
Customer Client	Date	
Drawn By Dessiné Par	BoxCad: Annie	Date 04/02/2015
Material Matière	16 Ga Electro-Galvanized (1.4mm)	
Color Couleur	Iron Grey RAL7011	Finish Fini Rough Textured
Description	Detail Rev.	
6500 MX 1600mm x 800mm x 1000mm Frame		
Part Number Numéro Pièce	Rev.	1 2
6500MXK160810FR	0	

SEE BILL OF MATERIAL ON LAST PAGE

This drawing is confidential and must not be reproduced or used without the consent of EXM

Ce dessin est confidentiel et ne doit pas être reproduit ou utilisé sans le consentement de EXM

No.	Revisions	Date	By/Par

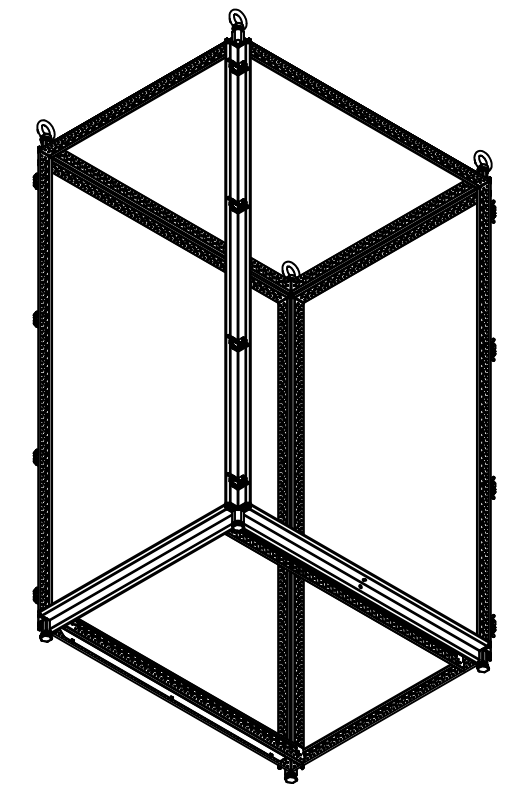

Isometric View



Qty	Part Number	Rev	Description
1	STK-P-03810R	0	Powder Paint (Iron Grey / Rough Textured)
1	STK-Q-49071	3	6500 MXM Inner Panel Slider 1000mm
1	STK-Q-49071-L	3	6500 MXM Inner Panel Slider 1000mm
4	STK-Q-49500	3	M12 Eye Bolt (0.34T)
4	STK-Q-61110	0	M12 Feet Leveler
8	STK-Q-00610	1	M18 x 30.5mm Bolt - Cover
4	STK-Q-47251-16	3	6500 MX 1600mm Vertical Frame Post Part
4	STK-Q-47250-08	3	6500 MX 800mm Horizontal Frame Post Part
4	STK-Q-47250-10	3	6500 MX 1000mm Horizontal Frame Post Part
8	STK-Q-49445	2	6500 MX - Frame Corner Bracket Casting
16	STK-K-11001	2	3 Way Fixed Bracket Kit
Parts List			

Tél: (450) 979-4373 Fax: (450) 979-4626 www.exmweb.com		Flatness Aplatissement Max 3.0mm Projection
Customer Client	Date	Date 04/02/2015
Drawn By Dessiné Par	BoxCad: Annie	
Material Matière	16 Ga Electro-Galvanized (1.4mm)	
Color Couleur	Iron Grey RAL7011	Finish Fini Rough Textured
Description	Detail Rev.	
6500 MX 1600mm x 800mm x 1000mm Frame		
Part Number Numéro Pièce	Rev.	2
6500MXK160810FR	0	2

This drawing is confidential and must not be reproduced or used without the consent of EXM

Ce dessin est confidentiel et ne doit pas être reproduit ou utilisé sans le consentement de EXM

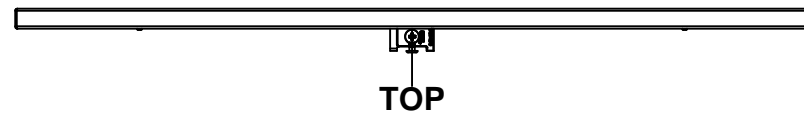

TOP

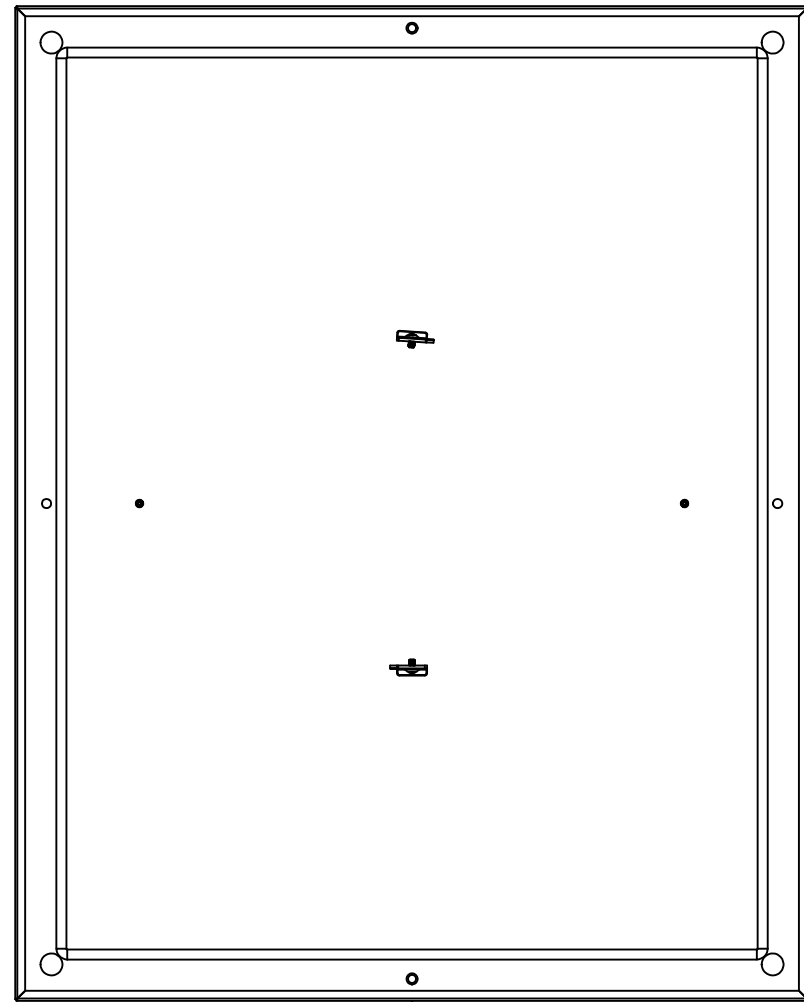

BACK



BOTTOM

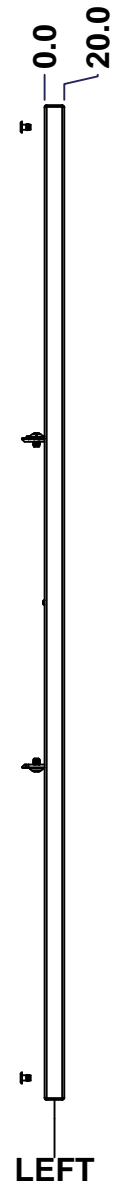

LEFT

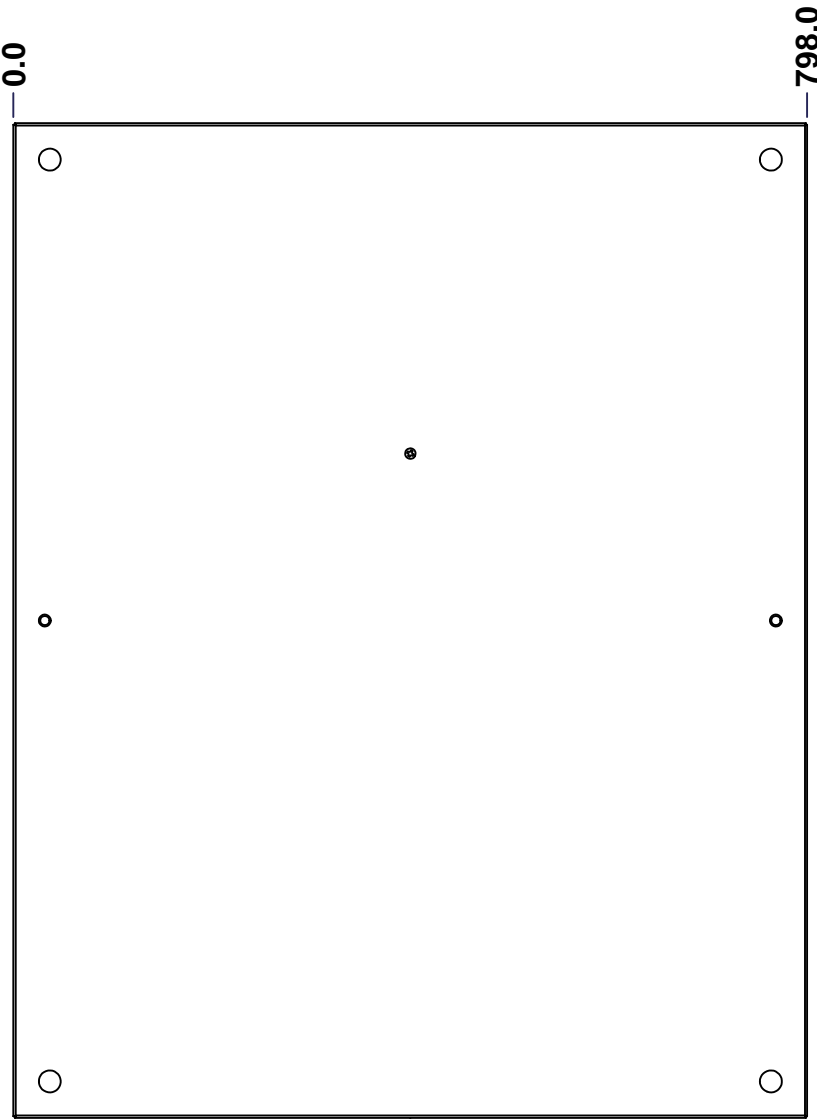

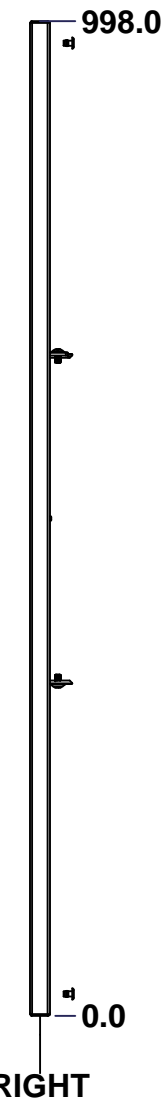

FRONT

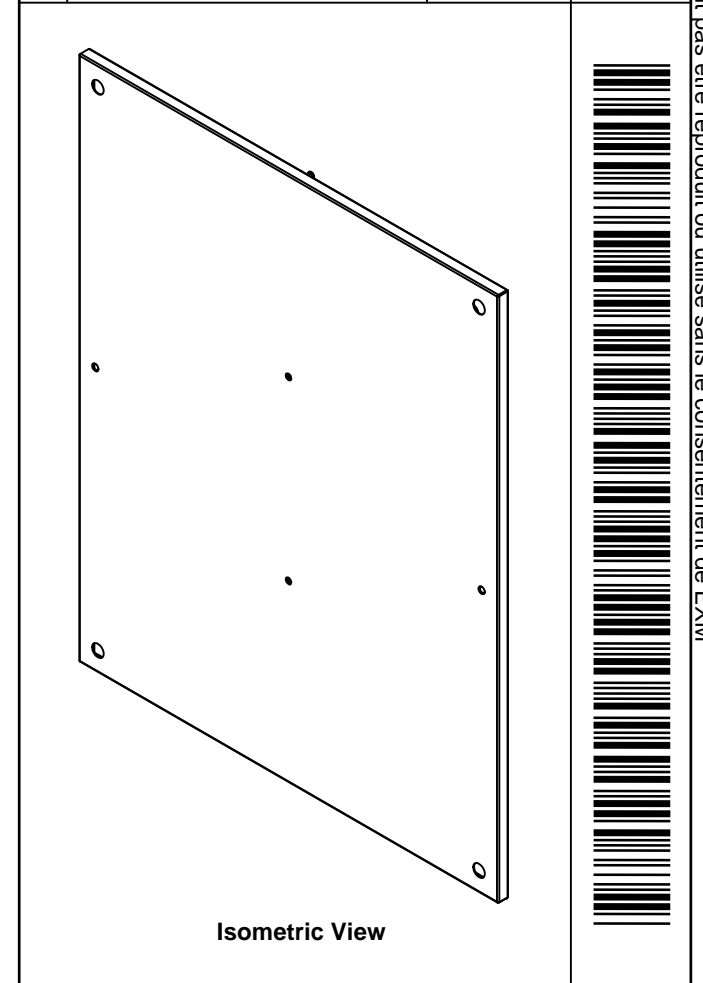

RIGHT

No.	Revisions	Date	By/Par



 Tél: (450) 979-4373 Fax: (450) 979-4626 www.exmweb.com		Flatness Aplatissement	
		Max 3.0mm	
Customer Client		Date	
Drawn By Dessiné Par BoxCad: Annie		Date 04/02/2015	
Material Matière 16 Ga H.R.P. & O. (1.4mm)			
Color Couleur Iron Grey RAL7011		Finish Fini Rough Textured	
Description 6500 MXT 800mm x 1000mm Top			Detail Rev.
Part Number Numéro Pièce 6500MXK160810T		Rev. 0	1 3

SEE BILL OF MATERIAL ON LAST PAGE

This drawing is confidential and must not be reproduced or used without the consent of EXM

Ce dessin est confidentiel et ne doit pas être reproduit ou utilisé sans le consentement de EXM

STANDARD FEATURES ARE NOT LISTED IN THIS HOLE TABLE			
HOLE TABLE - FRONT VIEW (CUSTOM FEATURE ONLY)			
CUT-OUT	XDIM	YDIM	DESCRIPTION
1	125.0	499.0	GND STUD M6 x 16mm (Inside)
2	673.0	499.0	GND STUD M6 x 16mm (Inside)

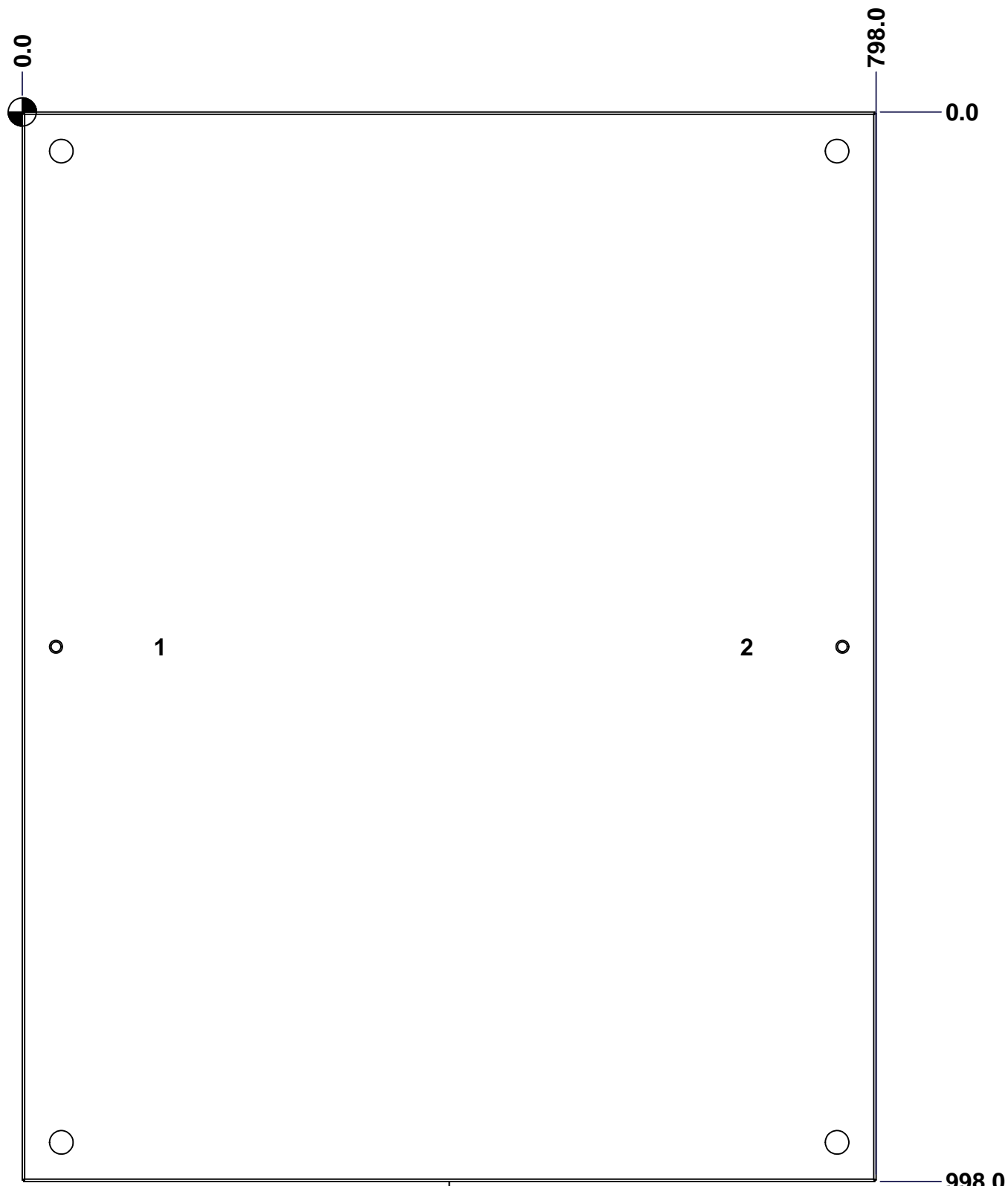

FRONT

	Description		Status
	6500 MXT 800mm x 1000mm Top		(NULL)
	Part Number Numéro Pièce		Rev.
	6500MXK160810T		0 / 2 / 3

This drawing is confidential and must not be reproduced or used without the consent of EXM

Ce dessin est confidentiel et ne doit pas être reproduit ou utilisé sans le consentement de EXM

No.	Revisions	Date	By/Par

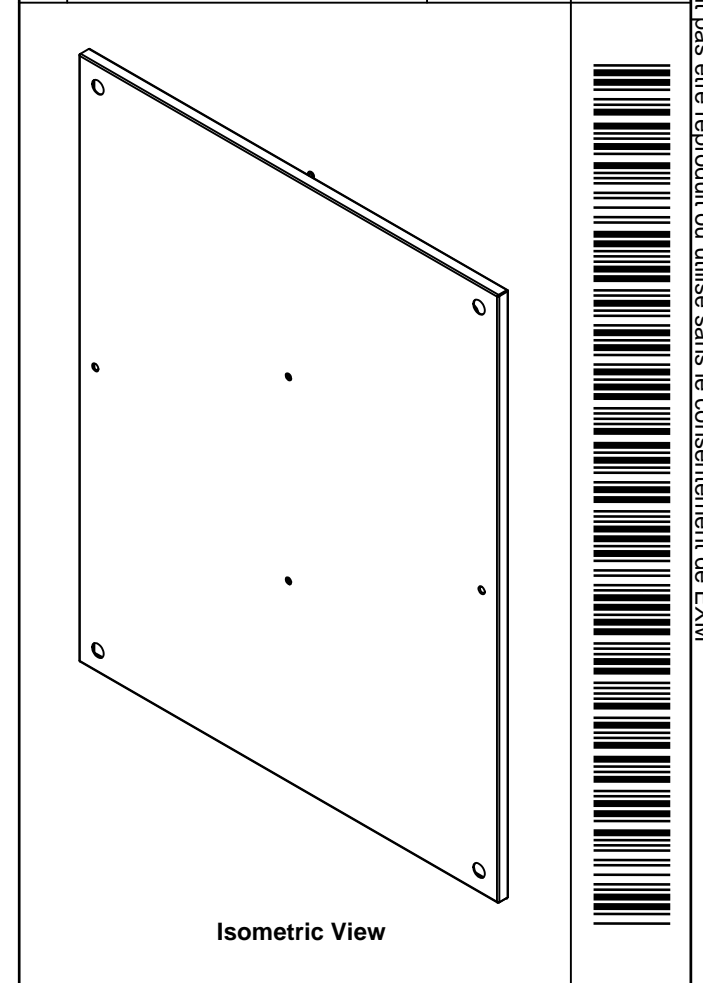

Tél: (450) 979-4373 Fax: (450) 979-4626 www.exmweb.com		Flatness Aplatissement	
		Max 3.0mm Projection	
Customer Client		Date	
Drawn By Dessiné Par BoxCad: Annie		Date 04/02/2015	
Material Matière		16 Ga H.R.P. & O. (1.4mm)	
Color Couleur Iron Grey RAL7011		Finish Fini Rough Textured	
Description 6500 MXT 800mm x 1000mm Top			Detail Rev.
Part Number Numéro Pièce		Rev.	3
6500MXK160810T		0	3

Qty	Part Number	Rev	Description
1	STK-P-03810R	0	Powder Paint (Iron Grey / Rough Textured)
2	STK-Q-16055	1	M6 x 18mm Stud (No Paint Cap Required)
2	STK-Q-77120	1	6500MX-Frame Rubber Plug
2	STK-Q-03072	2	M6 x 17mm Phillips Flat Head Screw
1	6500MXK160810TG	0	6500 MXT 800mm x 1000mm Top Gasket
1	6500MXK160810T-P	0	6500 MXT 800mm x 1000mm Top Part
2	STK-K-11010	3	Partial Fixed Bracket Kit
Parts List			

This drawing is confidential and must not be reproduced or used without the consent of EXM

Ce dessin est confidentiel et ne doit pas être reproduit ou utilisé sans le consentement de EXM

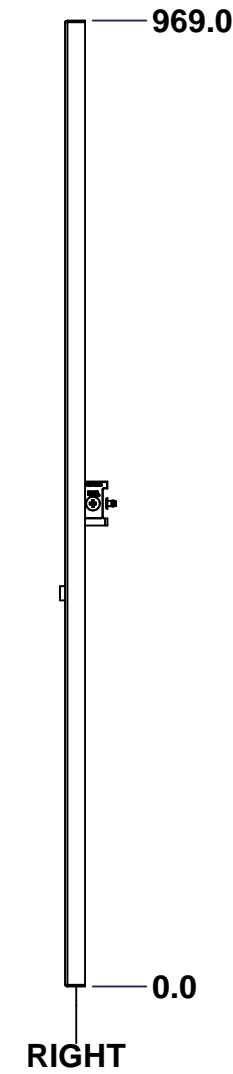
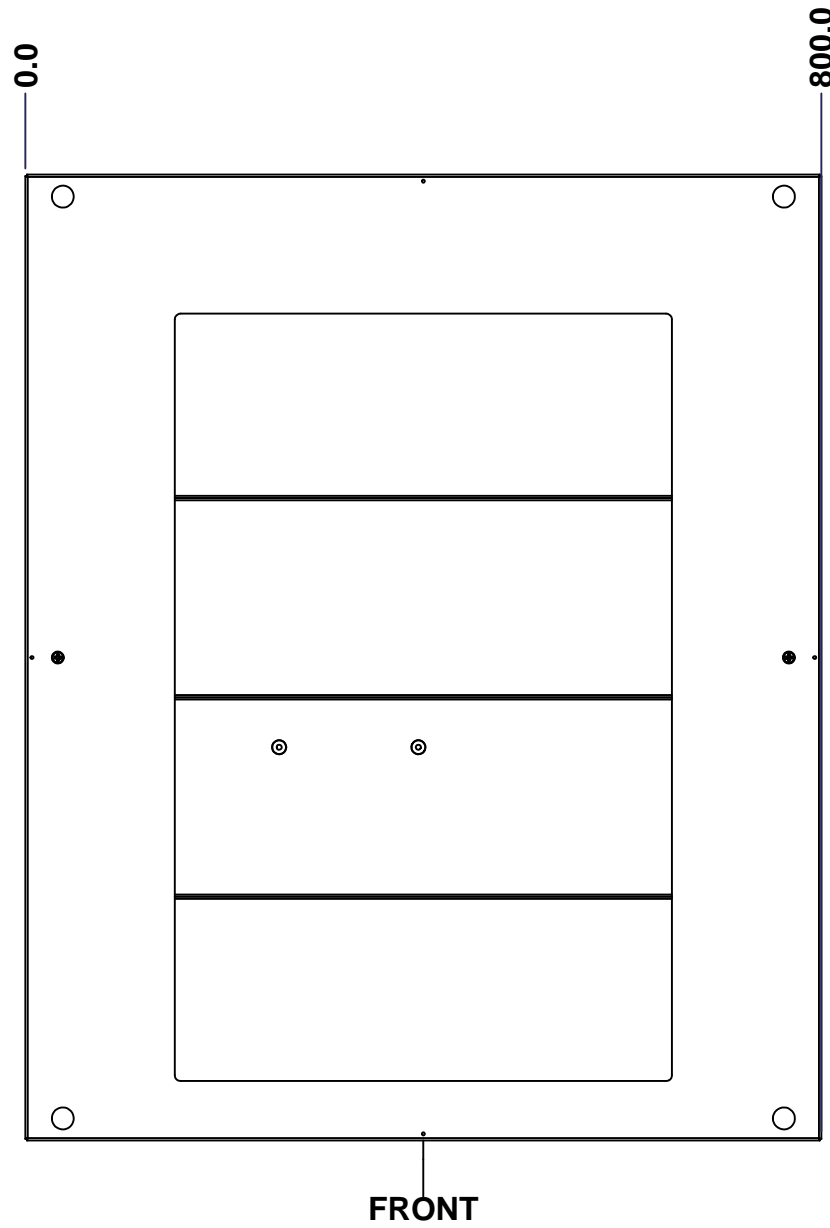
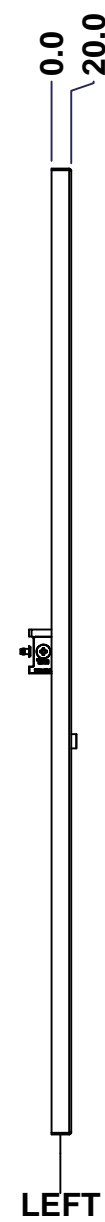
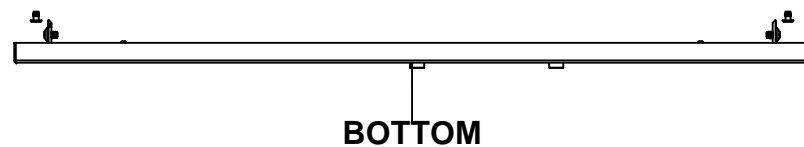
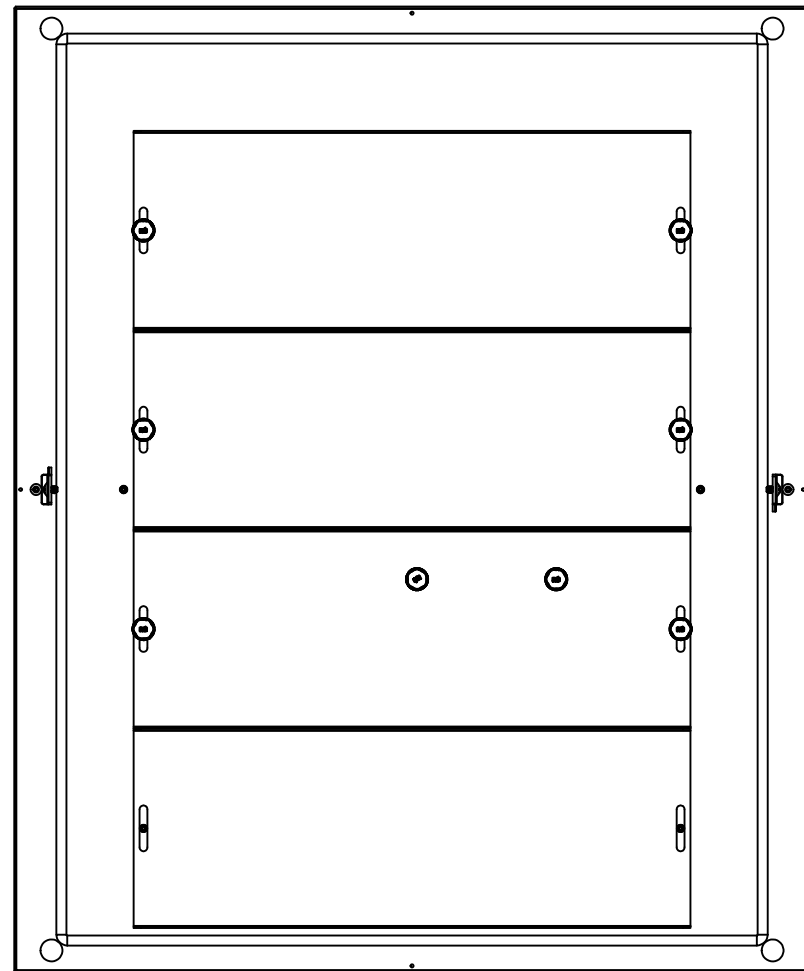
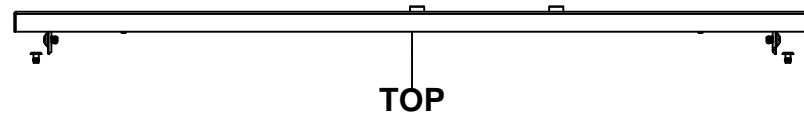

No.	Revisions	Date	By/Par

Isometric View

<p>Tél: (450) 979-4373 Fax: (450) 979-4626 www.exmweb.com</p>		Flatness Aplatissement	
		Max 3.0mm	
Customer Client		Date	
Drawn By Dessiné Par BoxCad: Annie		Date 04/02/2015	
Material Matière		16 Ga H.R.P. & O. (1.4mm)	
Color Couleur	Iron Grey RAL7011	Finish Fini	Rough Textured
Description		Detail Rev.	
6500 MXB 800mm x 1000mm Bottom			
Part Number Numéro Pièce		Rev.	1
6500MXK160810BT		0	3

SEE BILL OF MATERIAL ON LAST PAGE

This drawing is confidential and must not be reproduced or used without the consent of EXM

Ce dessin est confidentiel et ne doit pas être reproduit ou utilisé sans le consentement de EXM

STANDARD FEATURES ARE NOT LISTED IN THIS HOLE TABLE

HOLE TABLE - FRONT VIEW (CUSTOM FEATURE ONLY)

CUT-OUT	XDIM	YDIM	DESCRIPTION
1	110.0	484.5	GND STUD M6 x 16mm (Inside)
2	690.0	484.5	GND STUD M6 x 16mm (Inside)
3	130.0	744.5	GP STUD M6 x 10mm (Inside)
4	670.0	744.5	GP STUD M6 x 10mm (Inside)
5	130.0	544.5	GP STUD M6 x 10mm (Inside)
6	670.0	544.5	GP STUD M6 x 10mm (Inside)
7	130.0	344.5	GP STUD M6 x 10mm (Inside)
8	670.0	344.5	GP STUD M6 x 10mm (Inside)
9	130.0	144.5	GP STUD M6 x 10mm (Inside)
10	670.0	144.5	GP STUD M6 x 10mm (Inside)

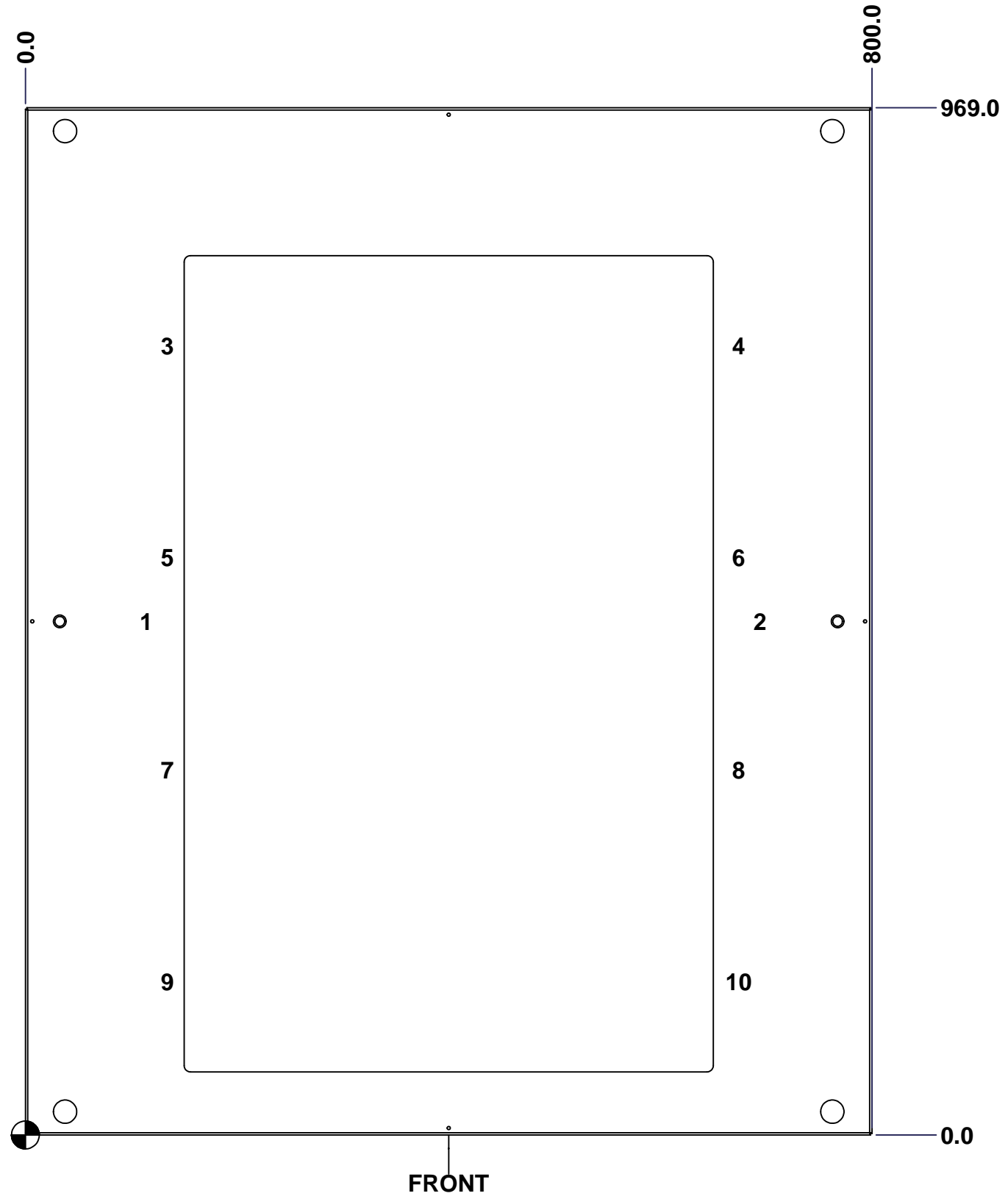

	Description	Status
	6500 MXB 800mm x 1000mm Bottom	(NULL)
	Part Number Numéro Pièce	Rev.
	6500MXK160810BT	0
		2
		3

This drawing is confidential and must not be reproduced or used without the consent of EXM

Ce dessin est confidentiel et ne doit pas être reproduit ou utilisé sans le consentement de EXM

No.	Revisions	Date	By/Par

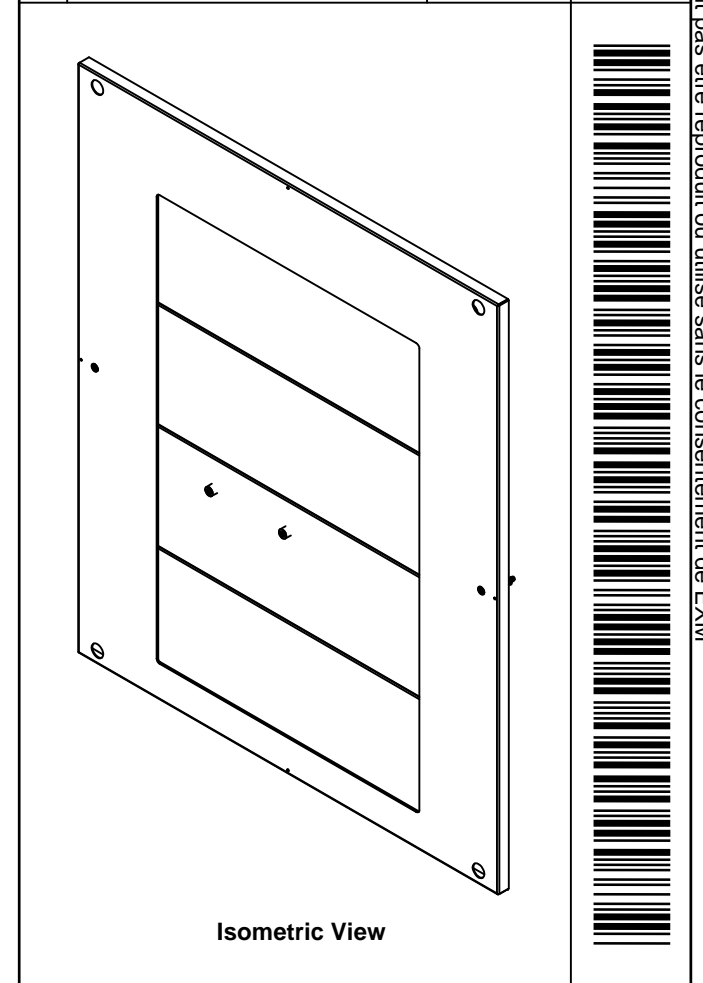

1	STK-P-03810R	0	Powder Paint (Iron Grey / Rough Textured)
2	STK-Q-06001	0	Mtrx - Gland Plate M6 Plastic Thumb Nut
2	STK-Q-16055	1	M6 x 18mm Stud (No Paint Cap Required)
2	STK-Q-77120	1	6500MX-Frame Rubber Plug
2	STK-Q-03072	2	M6 x 17mm Phillips Flat Head Screw
6			
4	6500MXK160810GP200-P	0	6500 MXB 800mm Gland Plate Part (200mm)
8	STK-Q-16031	0	M6 x 10mm Stud (No Paint Cap Required)
1	6500MXK160810BTGPG	0	6500 MXB 800mm x 1000mm Bottom Gland Plate Gasket
1	6500MXK160810BTG	0	6500 MXB 800mm x 1000mm Bottom Gasket
1	6500MXK160810BT-P	0	6500 MXB 800mm x 1000mm Bottom Part
2	STK-K-11010	3	Partial Fixed Bracket Kit
Qty	Part Number	Rev	Description
Parts List			

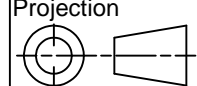
 Tél: (450) 979-4373 Fax: (450) 979-4626 www.exmweb.com		Flatness Aplatissement Max 3.0mm Projection 	
Customer Client		Date	
Drawn By / Dessiné Par: BoxCad: Annie		Date: 04/02/2015	
Material / Matière: 16 Ga H.R.P. & O. (1.4mm)			
Color / Couleur: Iron Grey RAL7011		Finish / Fini: Rough Textured	
Description: 6500 MXB 800mm x 1000mm Bottom			Detail Rev.
Part Number / Numéro Pièce: 6500MXK160810BT			Rev. 3
			0
			3

This drawing is confidential and must not be reproduced or used without the consent of EXM

Ce dessin est confidentiel et ne doit pas être reproduit ou utilisé sans le consentement de EXM

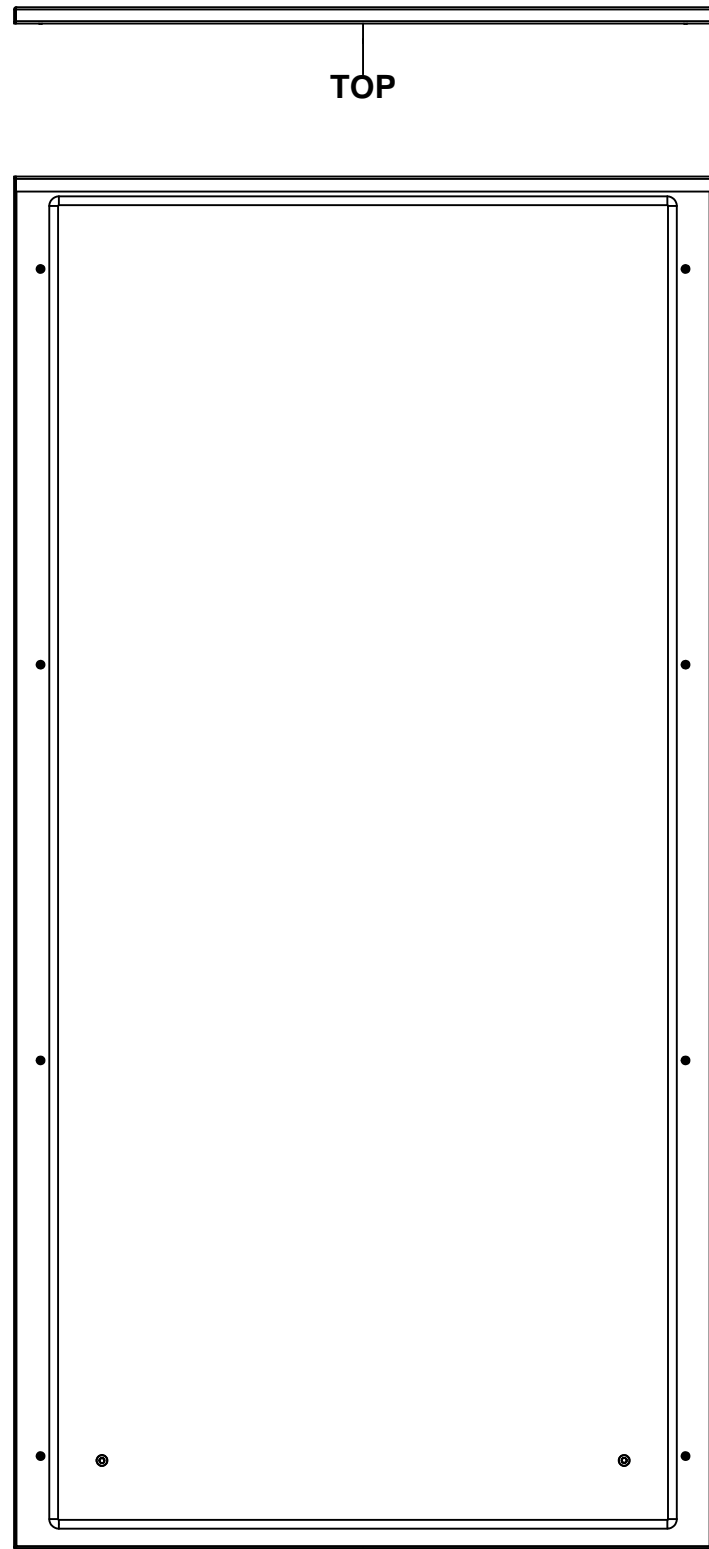

TOP

BACK

BOTTOM

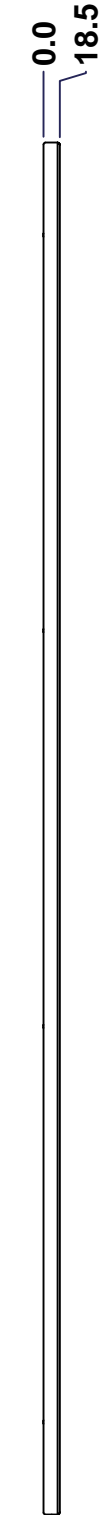

LEFT

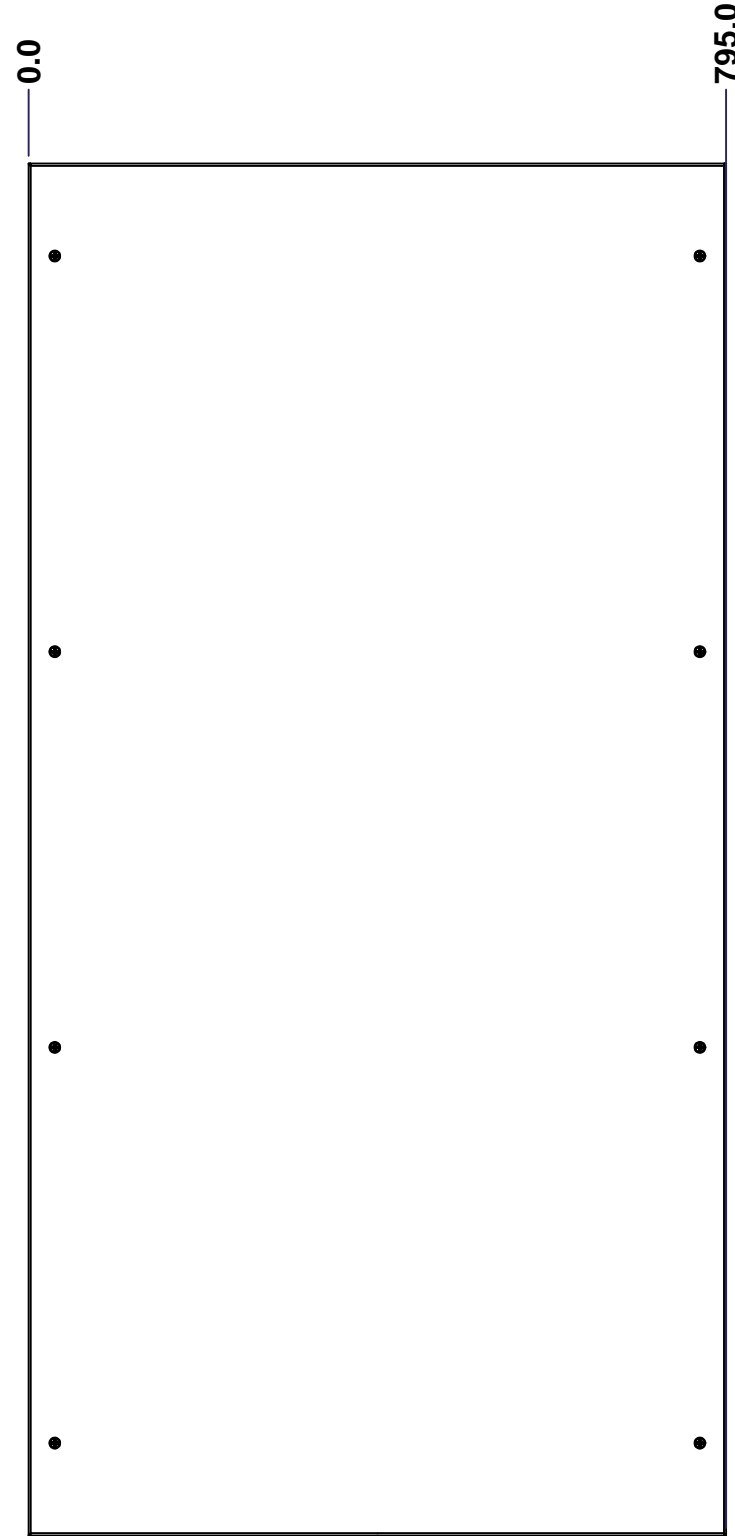

FRONT

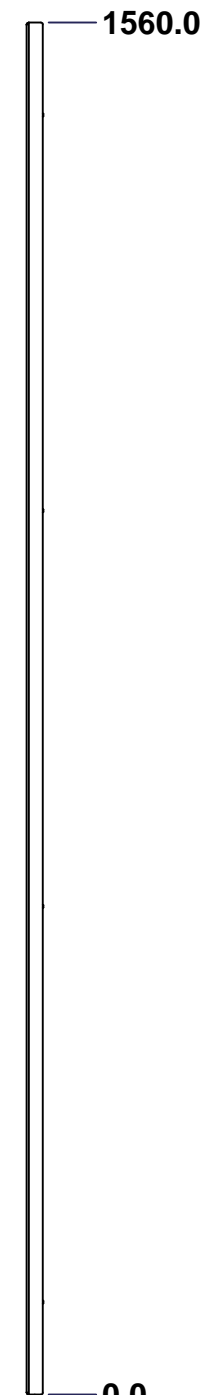

RIGHT

No.	Revisions	Date	By/Par

Isometric View

Tél: (450) 979-4373 Fax: (450) 979-4626 www.exmweb.com		Flatness Aplatissement	
		Max 3.0mm	
Customer Client		Projection	
Date			
Drawn By Dessiné Par		Date	
BoxCad: Annie		04/02/2015	
Material Matière		14 Ga H.R.P. & O. (1.7mm)	
Color Couleur		Light Grey RAL7035	Finish Fini
			Rough Textured
Description		Detail Rev.	
6500 MXR 1600mm x 800mm Back			
Part Number Numéro Pièce		Rev.	
6500MXK160810B		0	1 3

SEE BILL OF MATERIAL ON LAST PAGE

This drawing is confidential and must not be reproduced or used without the consent of EXM

Ce dessin est confidentiel et ne doit pas être reproduit ou utilisé sans le consentement de EXM

STANDARD FEATURES ARE NOT LISTED IN THIS HOLE TABLE			
HOLE TABLE - FRONT VIEW (CUSTOM FEATURE ONLY)			
CUT-OUT	XDIM	YDIM	DESCRIPTION
1	100.0	100.0	GND STUD M6 x 16mm (Inside)
2	695.0	100.0	GND STUD M6 x 16mm (Inside)

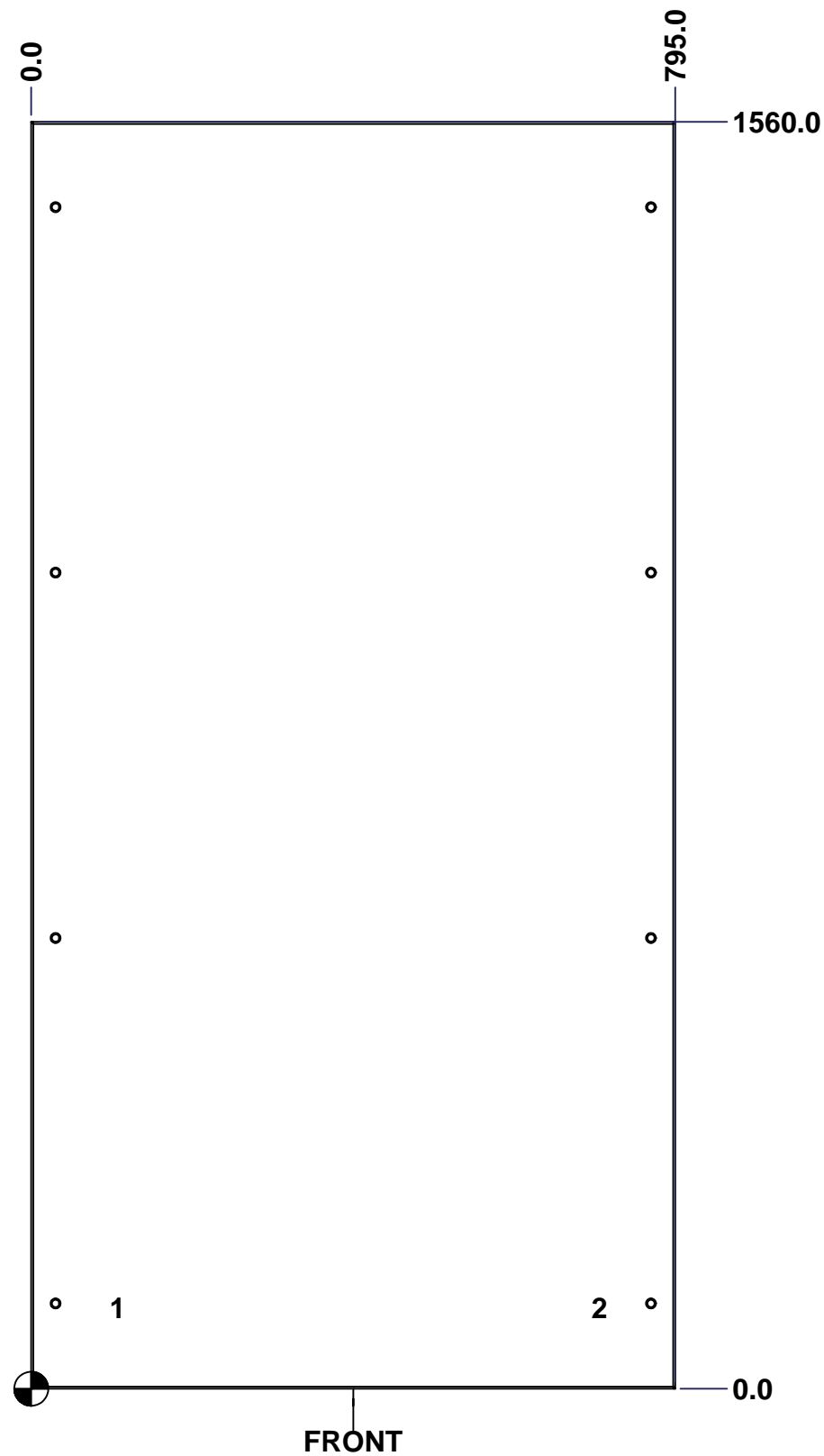

	Description	Status
	6500 MXR 1600mm x 800mm Back	(NULL)
	Part Number Numéro Pièce	Rev.
	6500MXK160810B	0
		2
		3

This drawing is confidential and must not be reproduced or used without the consent of EXM

Ce dessin est confidentiel et ne doit pas être reproduit ou utilisé sans le consentement de EXM

No.	Revisions	Date	By/Par

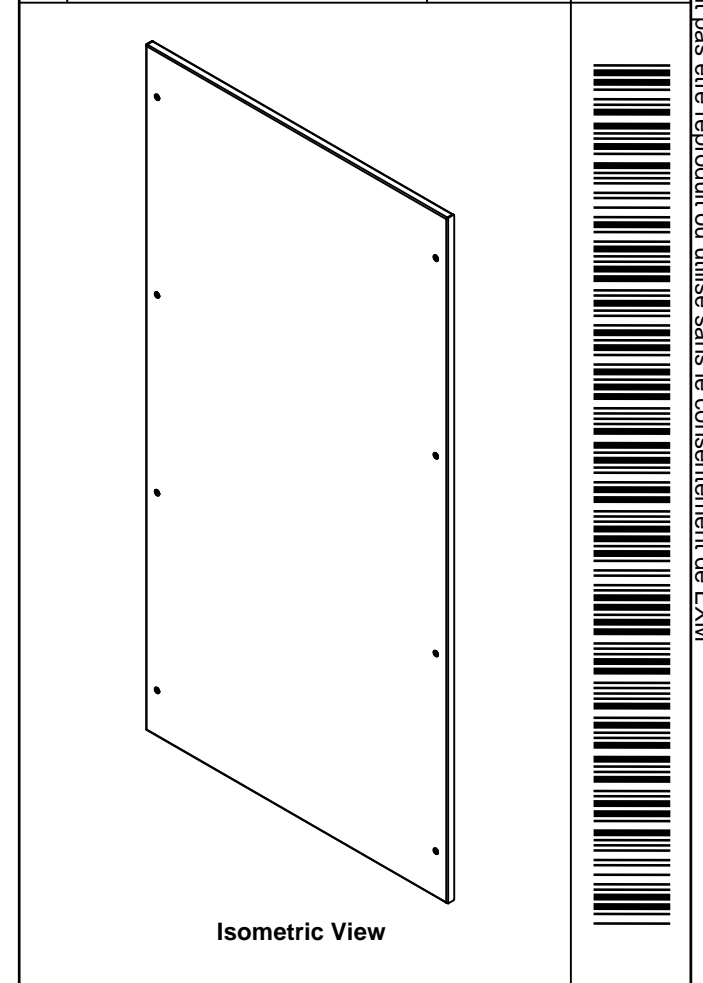

Tél: (450) 979-4373 Fax: (450) 979-4626 www.exmweb.com		Flatness Aplatissement	
		Max 3.0mm Projection	
Customer Client		Date	
Drawn By Dessiné Par BoxCad: Annie		Date 04/02/2015	
Material Matière 14 Ga H.R.P. & O. (1.7mm)			
Color Couleur Light Grey RAL7035		Finish Fini Rough Textured	
Description 6500 MXR 1600mm x 800mm Back			Detail Rev.
Part Number Numéro Pièce 6500MXK160810B		Rev. 0	3 3

Qty	Part Number	Rev	Description
1	STK-P-03820R	0	Powder Paint (Light Grey / Rough Textured)
8	STK-Q-03072	2	M6 x 17mm Phillips Flat Head Screw
2	STK-Q-16080	0.1.1	M6 x 16mm Ground Stud
1	6500MXK160810BG	0	6500 MXR 1600mm x 800mm Back Gasket
1	6500MXK160810B-P	0	6500 MXR 1600mm x 800mm Back Part
Parts List			

This drawing is confidential and must not be reproduced or used without the consent of EXM

Ce dessin est confidentiel et ne doit pas être reproduit ou utilisé sans le consentement de EXM



TOP

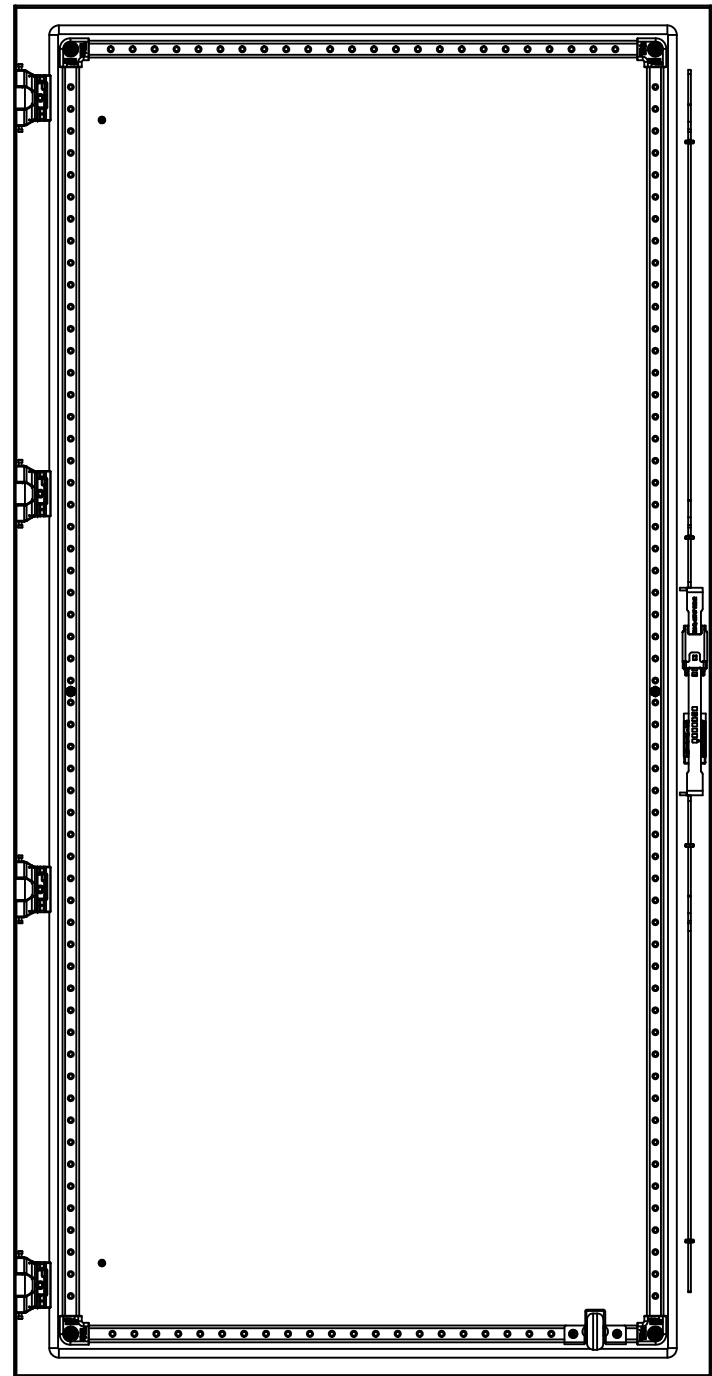

BACK



BOTTOM

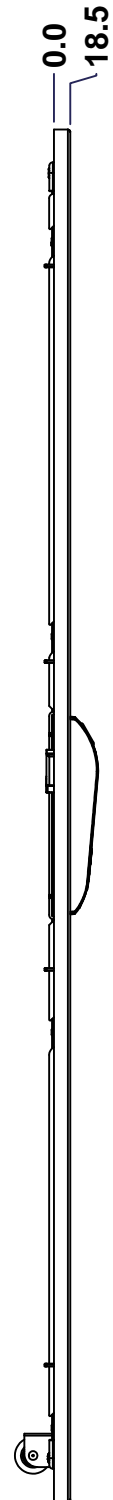

LEFT

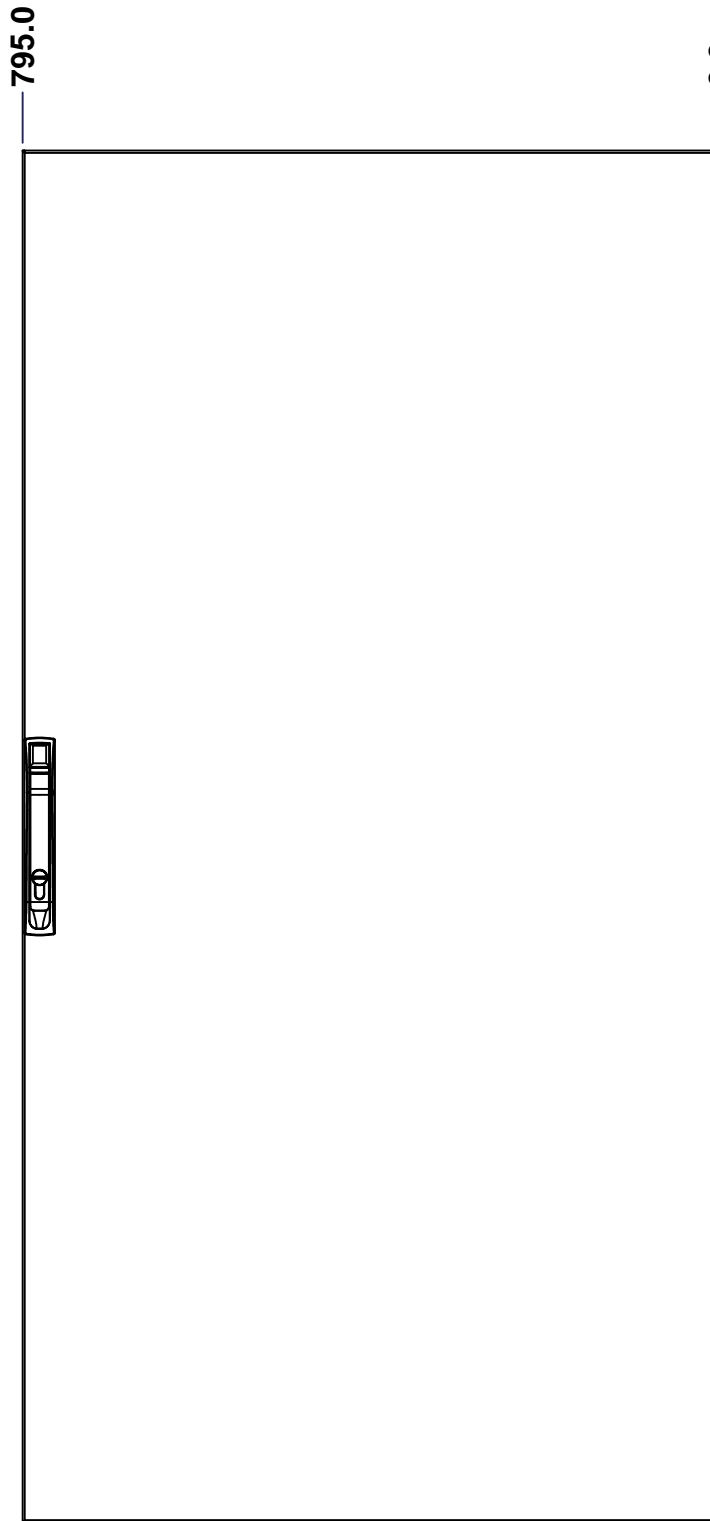

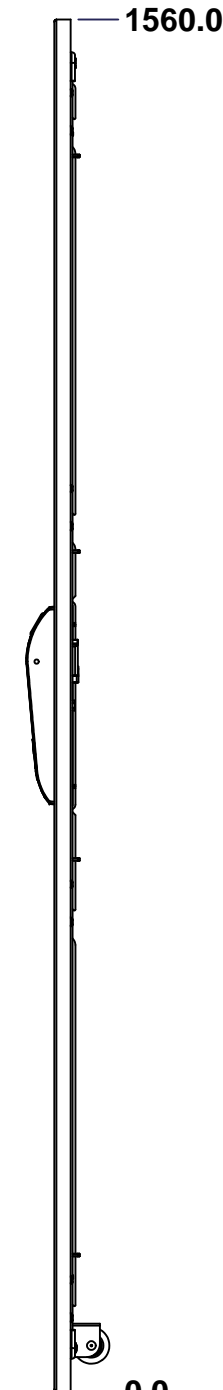

FRONT

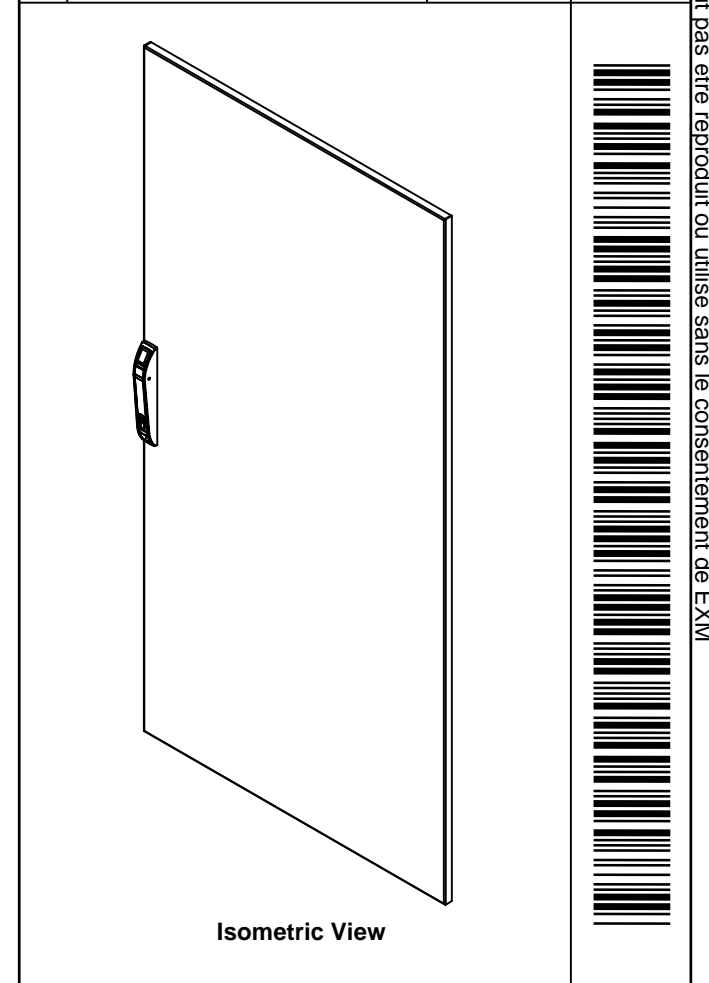

RIGHT

No.	Revisions	Date	By/Par

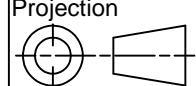

 Tél: (450) 979-4373 Fax: (450) 979-4626 www.exmweb.com		Flatness Aplatissement	
		Max 3.0mm	
Customer Client		Date	
Drawn By Dessiné Par BoxCad: Annie		Date 04/02/2015	
Material Matière 14 Ga H.R.P. & O. (1.7mm)		 Projection	
Color Couleur Light Grey RAL7035	Finish Fini Rough Textured	Description	
6500 MXD 1600mm x 800mm Front		Detail Rev.	
Part Number Numéro Pièce 6500MXK160810F		Rev. 0	1 3

SEE BILL OF MATERIAL ON LAST PAGE

This drawing is confidential and must not be reproduced or used without the consent of EXM

Ce dessin est confidentiel et ne doit pas être reproduit ou utilisé sans le consentement de EXM

STANDARD FEATURES ARE NOT LISTED IN THIS HOLE TABLE

HOLE TABLE - FRONT VIEW (CUSTOM FEATURE ONLY)

CUT-OUT	XDIM	YDIM	DESCRIPTION
1	100.0	130.0	GND STUD M6 x 16mm (Inside)
2	100.0	1430.0	GND STUD M6 x 16mm (Inside)
3	64.5	49.5	STIFF. STUD M6 x 18mm (Inside)
4	64.5	780.0	STIFF. STUD M6 x 18mm (Inside)
5	64.5	1510.5	STIFF. STUD M6 x 18mm (Inside)
6	730.5	49.5	STIFF. STUD M6 x 18mm (Inside)
7	730.5	780.0	STIFF. STUD M6 x 18mm (Inside)
8	730.5	1510.5	STIFF. STUD M6 x 18mm (Inside)
9	769.5	155.0	CLOSING BAR GUIDE (Inside)
10	769.5	1405.0	CLOSING BAR GUIDE (Inside)
11	769.5	605.0	CLOSING BAR GUIDE (Inside)
12	769.5	955.0	CLOSING BAR GUIDE (Inside)

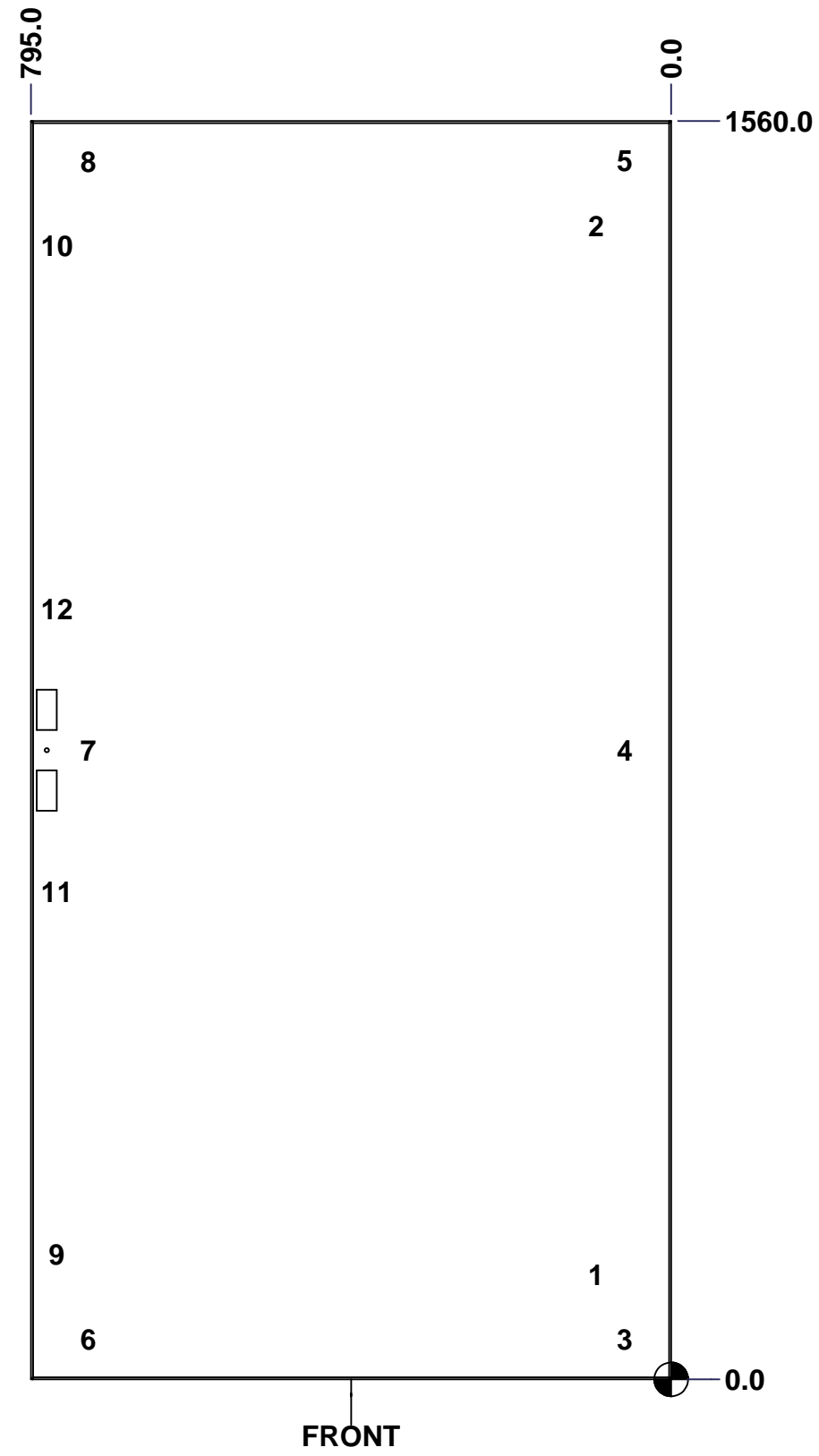

	Description 6500 MXD 1600mm x 800mm Front	Status (NULL)
	Part Number Numéro Pièce 6500MXK160810F	Rev. 2 0

This drawing is confidential and must not be reproduced or used without the consent of EXM

Ce dessin est confidentiel et ne doit pas être reproduit ou utilisé sans le consentement de EXM

No.	Revisions	Date	By/Par

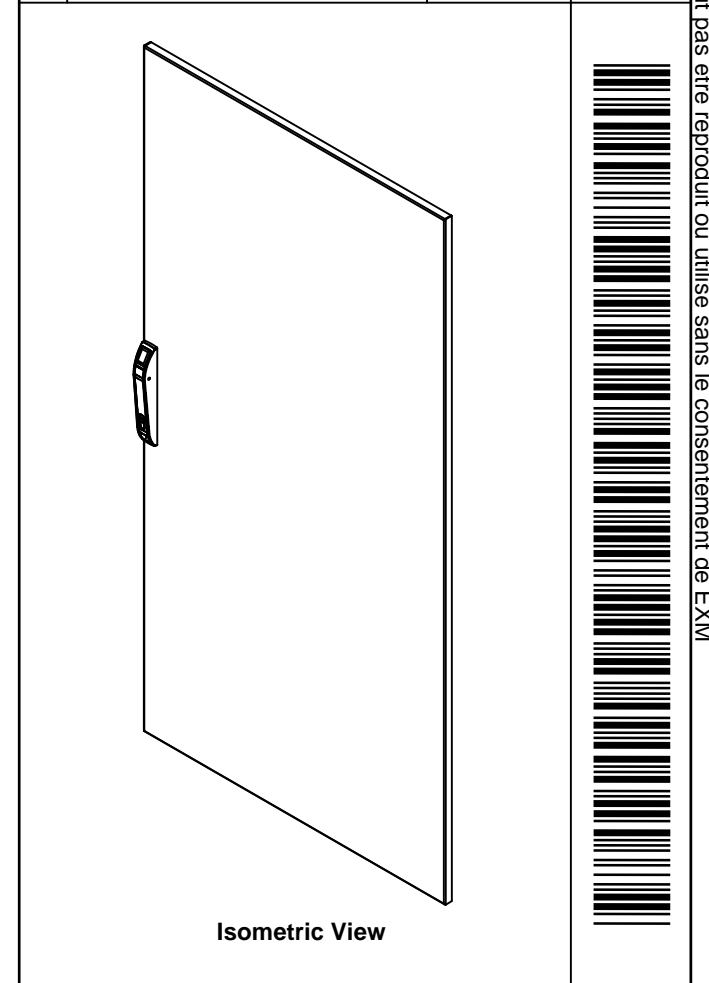

1	STK-P-03820R	0	Powder Paint (Light Grey / Rough Textured)
1	6500MXSRK	1	6500 MXRSK Door Support Roller
4	STK-Q-78022	0	Mtrx Closing Bar Slider
1	STK-Q-45746-16	1	6500 MXD - Lock Door Closing Bar
4	STK-Q-33105	4	5412 ESBU Buttable Hinge (Cover Part)
1	STK-Q-45729-16	2	6500 MXD - Lock Door Top Closing Bar
1	886PHD-S	4	Euroform Pull Handle Kit
8	STK-Q-16055	1	M6 x 18mm Stud (No Paint Cap Required)
1	6500MXK160810DS1	5	6500 MX 1600mm x 800mm Door Stiffener
1	6500MXK160810FG	0	6500 MXD 1600mm x 800mm Front Gasket
1	6500MXK160810F-P	0	6500 MXD 1600mm x 800mm Front Part
4	STK-K-06811	1	6500 MX - Hinge Assy
Qty	Part Number	Rev	Description
Parts List			

<p>Tél: (450) 979-4373 Fax: (450) 979-4626 www.exmweb.com</p>	Flatness Aplatissement	Max 3.0mm
	Projection	
Customer Client	Date	
Drawn By Dessiné Par	BoxCad: Annie	Date 04/02/2015
Material Matière	14 Ga H.R.P. & O. (1.7mm)	
Color Couleur	Light Grey RAL7035	Finish Fini Rough Textured
Description	Detail Rev.	
6500 MXD 1600mm x 800mm Front		
Part Number Numéro Pièce	Rev.	3
6500MXK160810F	0	3

This drawing is confidential and must not be reproduced or used without the consent of EXM

Ce dessin est confidentiel et ne doit pas être reproduit ou utilisé sans le consentement de EXM

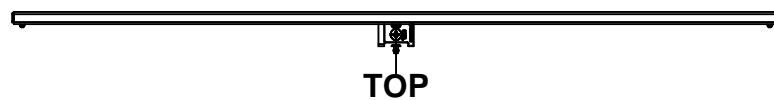

TOP

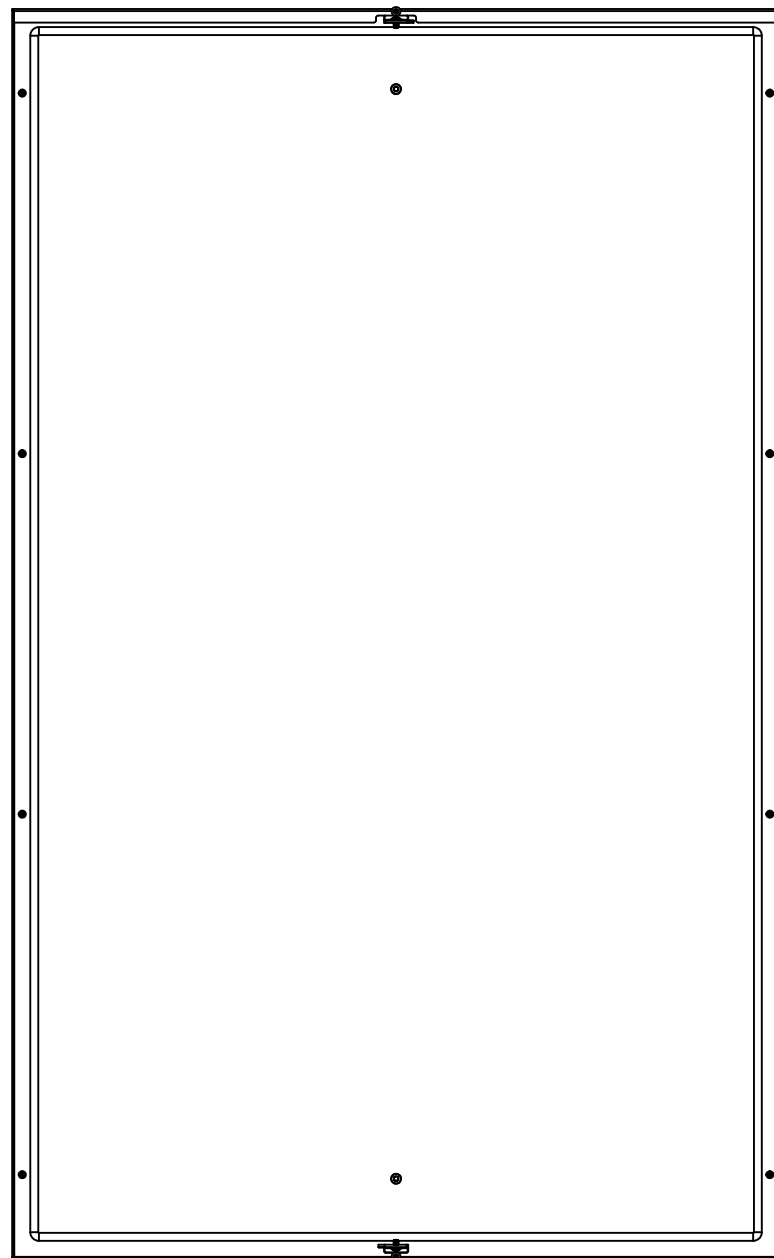

BACK

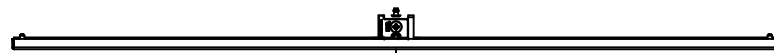

BOTTOM

0.0
13.0

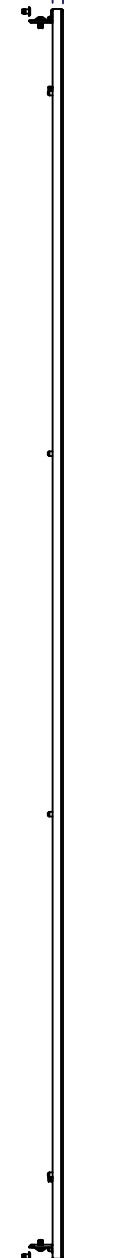

LEFT

0.0
960.0

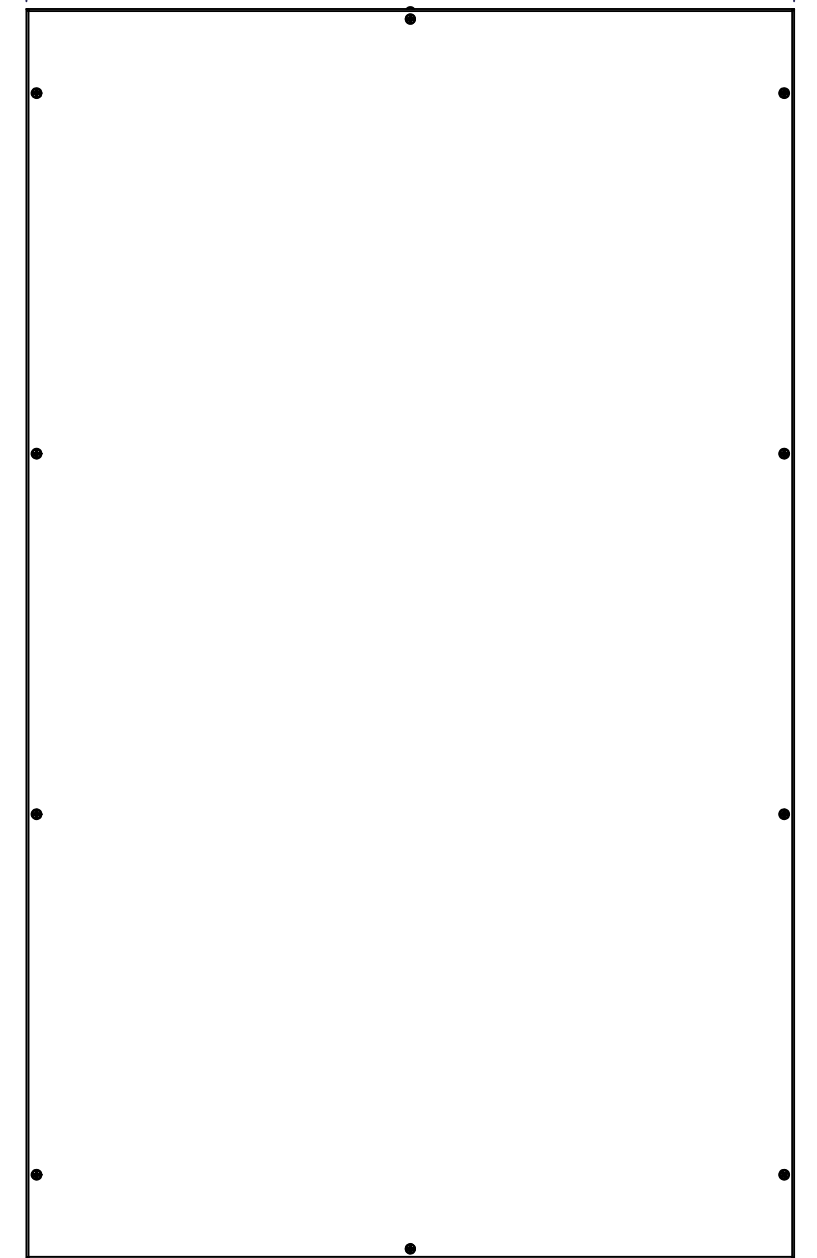

FRONT

1560.0

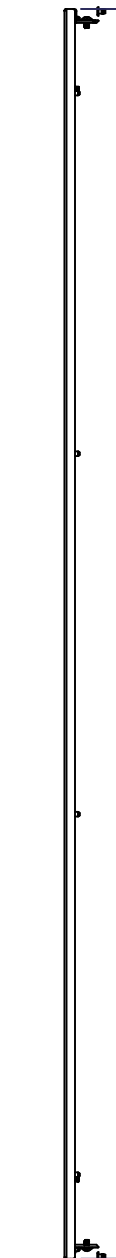

RIGHT

0.0

No.	Revisions	Date	By/Par

Isometric View

<p>Tél: (450) 979-4373 Fax: (450) 979-4626 www.exmweb.com</p>		Flatness Aplatissement	
		Max 3.0mm	
Customer Client		Projection	
Date			
Drawn By Dessiné Par		Date	
BoxCad: Annie		04/02/2015	
Material Matière		14 Ga H.R.P. & O. (1.7mm)	
Color Couleur		Finish Fini	
Light Grey RAL7035		Rough Textured	
Description		Detail Rev.	
6500 MXC 1600mm x 1000mm Left			
Part Number Numéro Pièce		Rev.	
6500MXK160810L		0	
		1	
		3	

SEE BILL OF MATERIAL ON LAST PAGE

This drawing is confidential and must not be reproduced or used without the consent of EXM

Ce dessin est confidentiel et ne doit pas être reproduit ou utilisé sans le consentement de EXM

STANDARD FEATURES ARE NOT LISTED IN THIS HOLE TABLE			
HOLE TABLE - FRONT VIEW (CUSTOM FEATURE ONLY)			
CUT-OUT	XDIM	YDIM	DESCRIPTION
1	480.0	100.0	GND STUD M6 x 16mm (Inside)
2	480.0	1460.0	GND STUD M6 x 16mm (Inside)

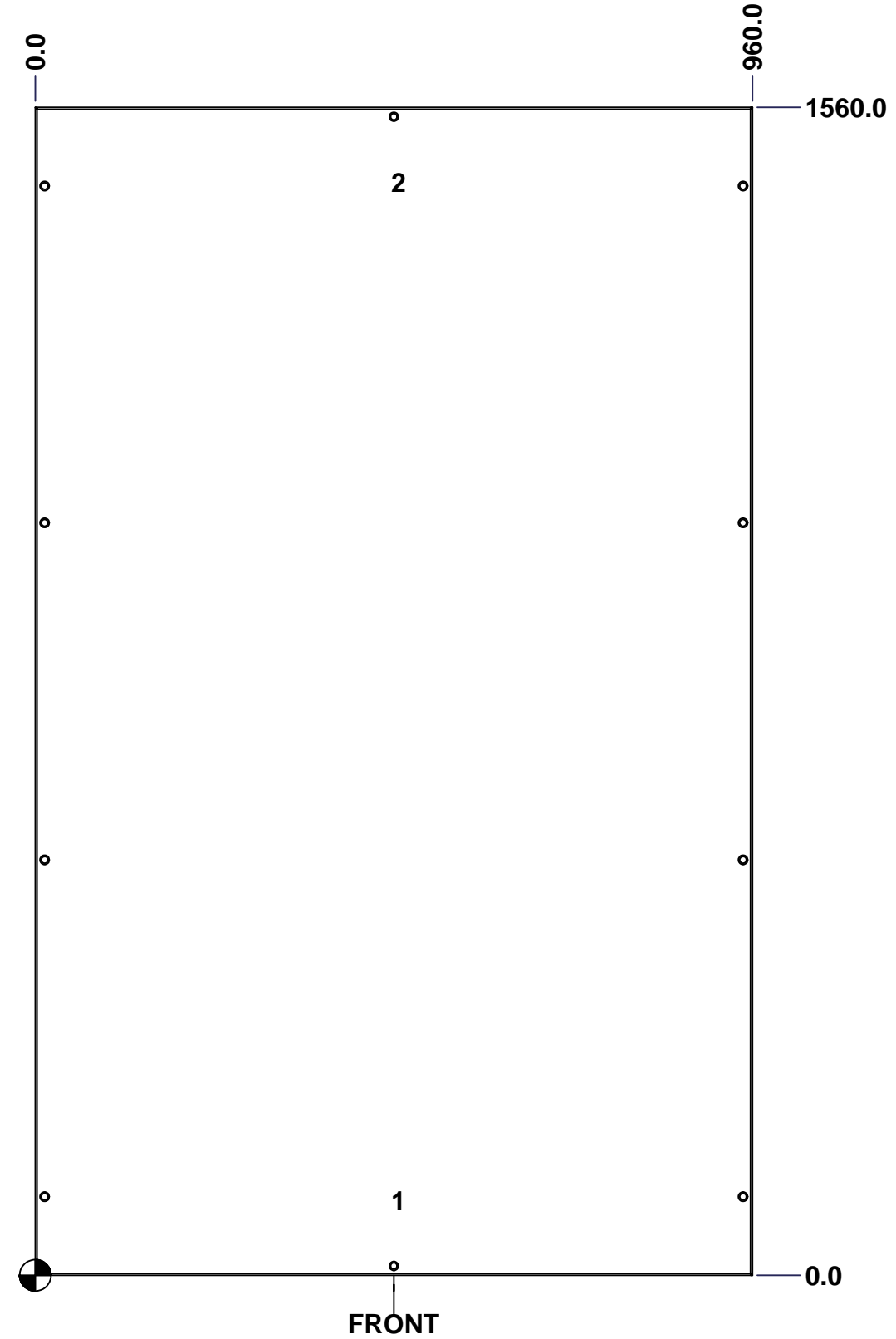



	Description	Status
	6500 MXC 1600mm x 1000mm Left	(NULL)
	Part Number Numéro Pièce	Rev.
	6500MXK160810L	0
		2
		3

This drawing is confidential and must not be reproduced or used without the consent of EXM

Ce dessin est confidentiel et ne doit pas être reproduit ou utilisé sans le consentement de EXM

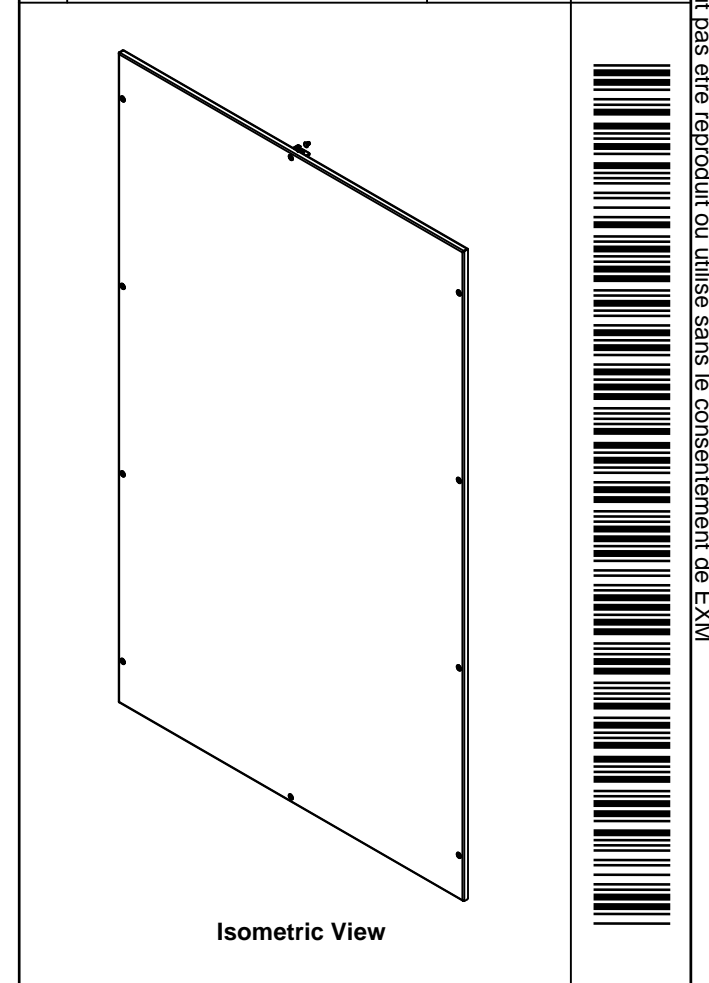
No.	Revisions	Date	By/Par

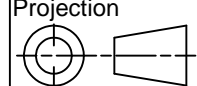

 Tél: (450) 979-4373 Fax: (450) 979-4626 www.exmweb.com		Flatness Aplatissement Max 3.0mm Projection 
Customer Client	Date	
Drawn By Dessiné Par	BoxCad: Annie	Date 04/02/2015
Material Matière	14 Ga H.R.P. & O. (1.7mm)	
Color Couleur	Light Grey RAL7035	Finish Fini Rough Textured
Description		Detail Rev.
6500 MXC 1600mm x 1000mm Left		
Part Number Numéro Pièce	Rev.	3
6500MXK160810L	0	3

Qty	Part Number	Rev	Description
1	STK-P-03820R	0	Powder Paint (Light Grey / Rough Textured)
2	STK-Q-77120	1	6500MX-Frame Rubber Plug
10	STK-Q-03072	2	M6 x 17mm Phillips Flat Head Screw
2	STK-Q-16080	0.1.1	M6 x 16mm Ground Stud
1	6500MXK160810LG	0	6500 MXC 1600mm x 1000mm Left Gasket
1	6500MXK160810L-P	0	6500 MXC 1600mm x 1000mm Left Part
2	STK-K-11010	3	Partial Fixed Bracket Kit
Parts List			

This drawing is confidential and must not be reproduced or used without the consent of EXM

Ce dessin est confidentiel et ne doit pas être reproduit ou utilisé sans le consentement de EXM

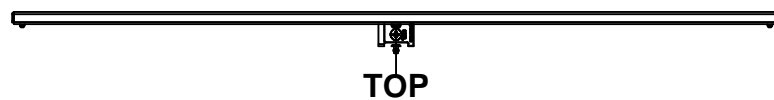

TOP

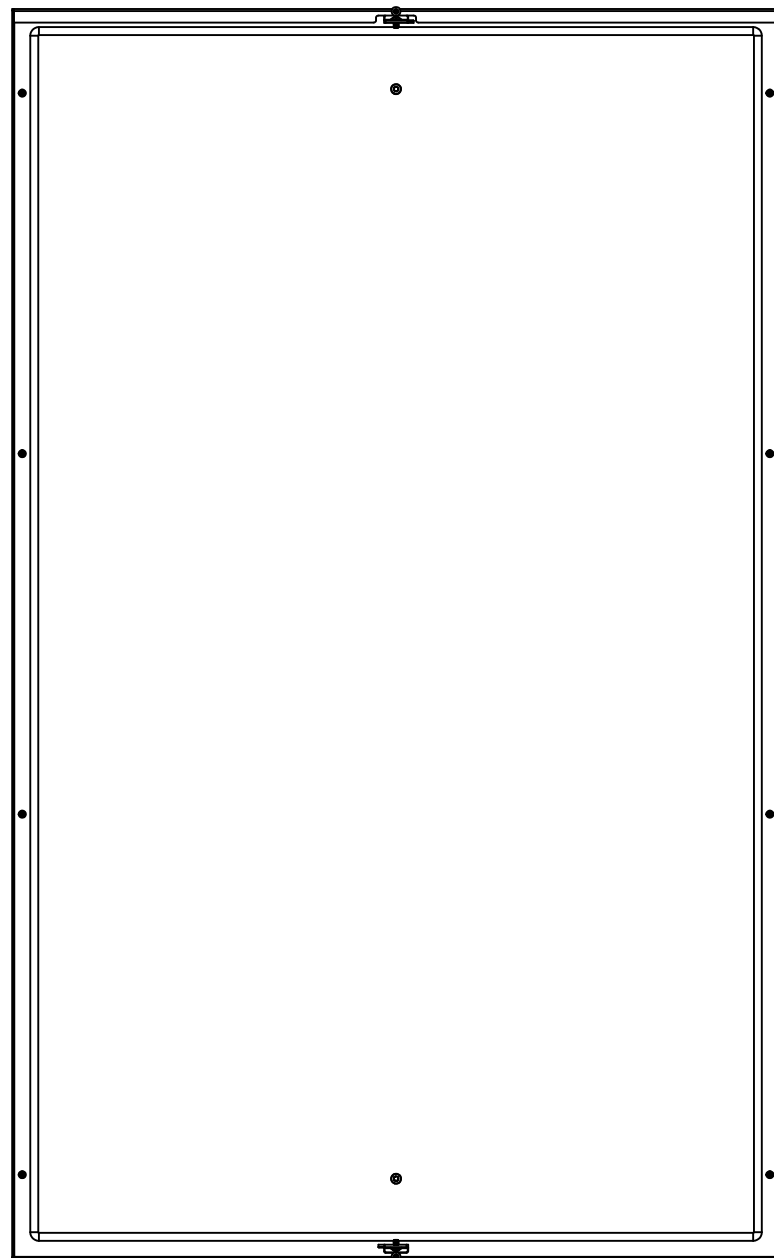

BACK

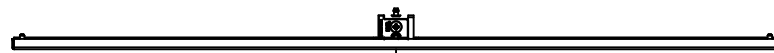

BOTTOM

0.0
13.0

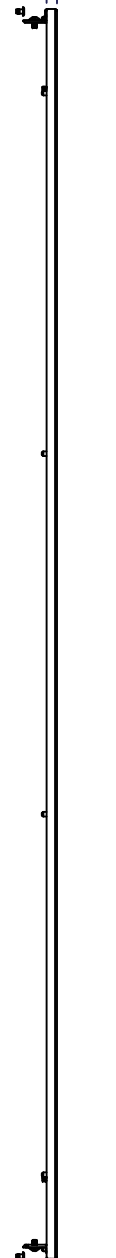

LEFT

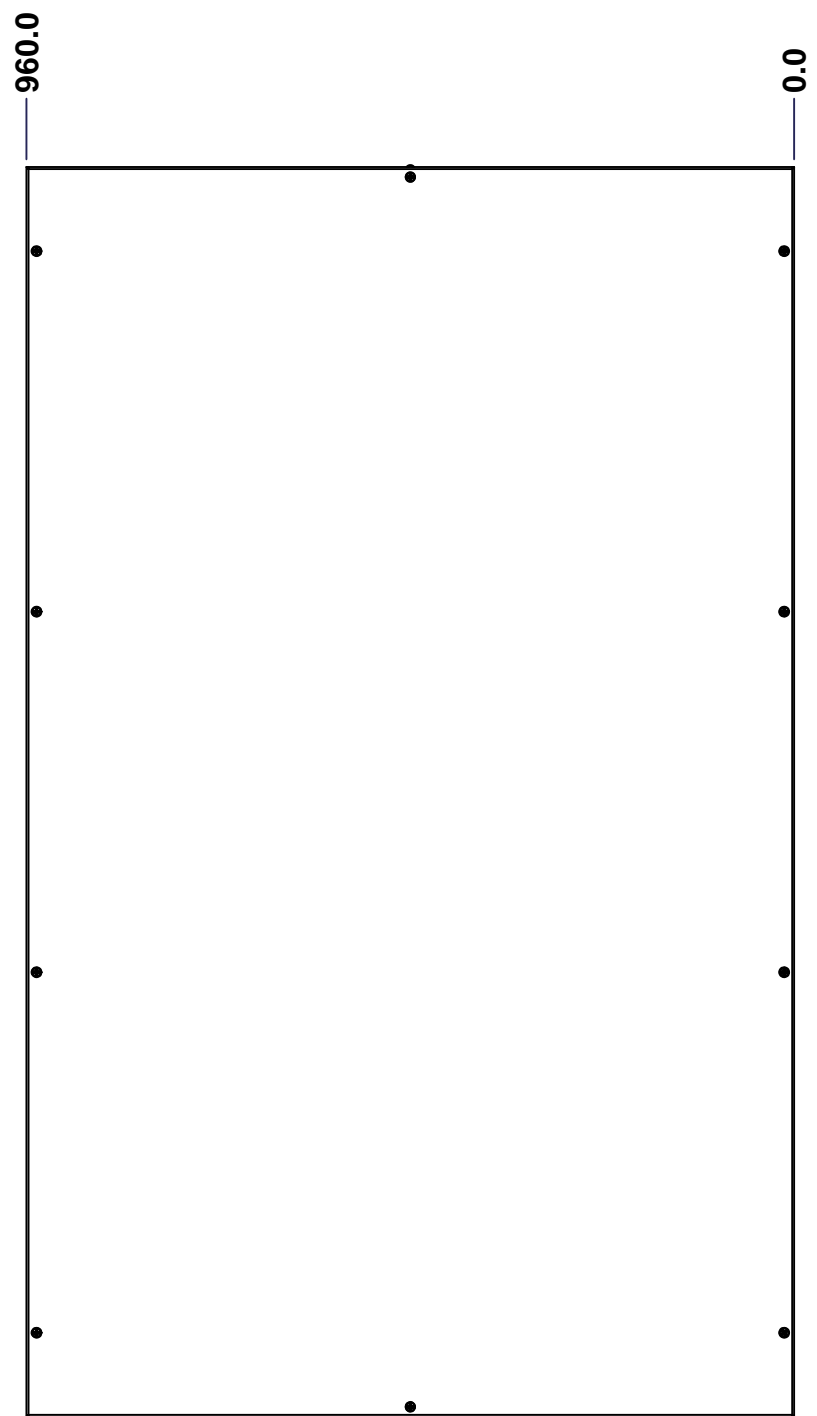

FRONT

0.0

1560.0

RIGHT

0.0

No.	Revisions	Date	By/Par

Isometric View

		Flatness Aplatissement Max 3.0mm	
Tél: (450) 979-4373 Fax: (450) 979-4626 www.exmweb.com		Projection 	
Customer Client		Date	
Drawn By Dessiné Par BoxCad: Annie		Date 04/02/2015	
Material Matière		14 Ga H.R.P. & O. (1.7mm)	
Color Couleur	Light Grey RAL7035	Finish Fini	Rough Textured
Description		Detail Rev.	
6500 MXC 1600mm x 1000mm Right			
Part Number Numéro Pièce		Rev.	1
6500MXK160810R		0	3

SEE BILL OF MATERIAL ON LAST PAGE

This drawing is confidential and must not be reproduced or used without the consent of EXM

Ce dessin est confidentiel et ne doit pas être reproduit ou utilisé sans le consentement de EXM

STANDARD FEATURES ARE NOT LISTED IN THIS HOLE TABLE			
HOLE TABLE - FRONT VIEW (CUSTOM FEATURE ONLY)			
CUT-OUT	XDIM	YDIM	DESCRIPTION
1	480.0	100.0	GND STUD M6 x 16mm (Inside)
2	480.0	1460.0	GND STUD M6 x 16mm (Inside)

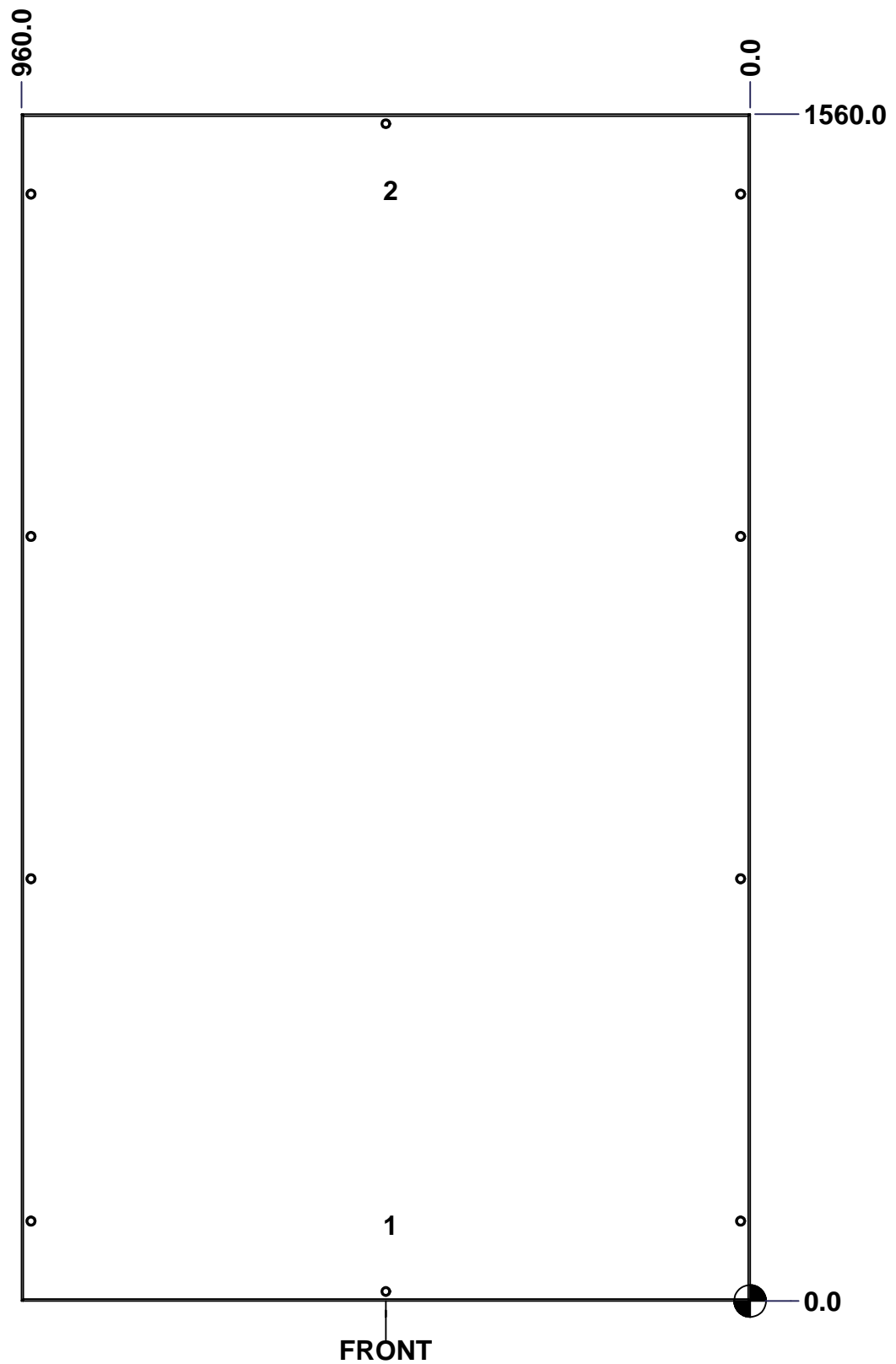



	Description	Status
	6500 MXC 1600mm x 1000mm Right	(NULL)
	Part Number Numéro Pièce	Rev.
	6500MXK160810R	0
		2
		3

This drawing is confidential and must not be reproduced or used without the consent of EXM

Ce dessin est confidentiel et ne doit pas être reproduit ou utilisé sans le consentement de EXM

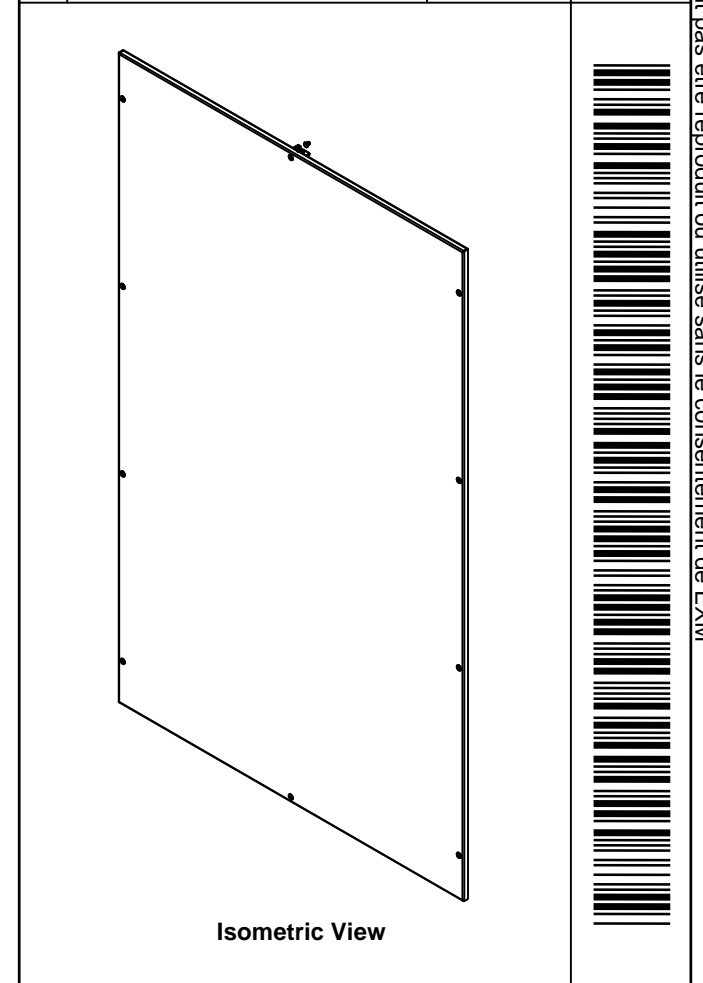
No.	Revisions	Date	By/Par

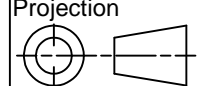

 Tél: (450) 979-4373 Fax: (450) 979-4626 www.exmweb.com		Flatness Aplatissement Max 3.0mm Projection 
Customer Client	Date	Date
Drawn By Dessiné Par	BoxCad: Annie	Date 04/02/2015
Material Matière	14 Ga H.R.P. & O. (1.7mm)	
Color Couleur	Light Grey RAL7035	Finish Fini Rough Textured
Description	Detail Rev.	
6500 MXC 1600mm x 1000mm Right		
Part Number Numéro Pièce	Rev.	3
6500MXK160810R		0

Qty	Part Number	Rev	Description
1	STK-P-03820R	0	Powder Paint (Light Grey / Rough Textured)
2	STK-Q-77120	1	6500MX-Frame Rubber Plug
10	STK-Q-03072	2	M6 x 17mm Phillips Flat Head Screw
2	STK-Q-16080	0.1.	M6 x 16mm Ground Stud
1	6500MXK160810LG	0	6500 MXC 1600mm x 1000mm Left Gasket
1	6500MXK160810L-P	0	6500 MXC 1600mm x 1000mm Left Part
2	STK-K-11010	3	Partial Fixed Bracket Kit
Parts List			

This drawing is confidential and must not be reproduced or used without the consent of EXM

Ce dessin est confidentiel et ne doit pas être reproduit ou utilisé sans le consentement de EXM

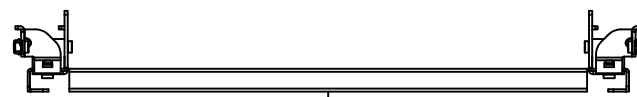

TOP

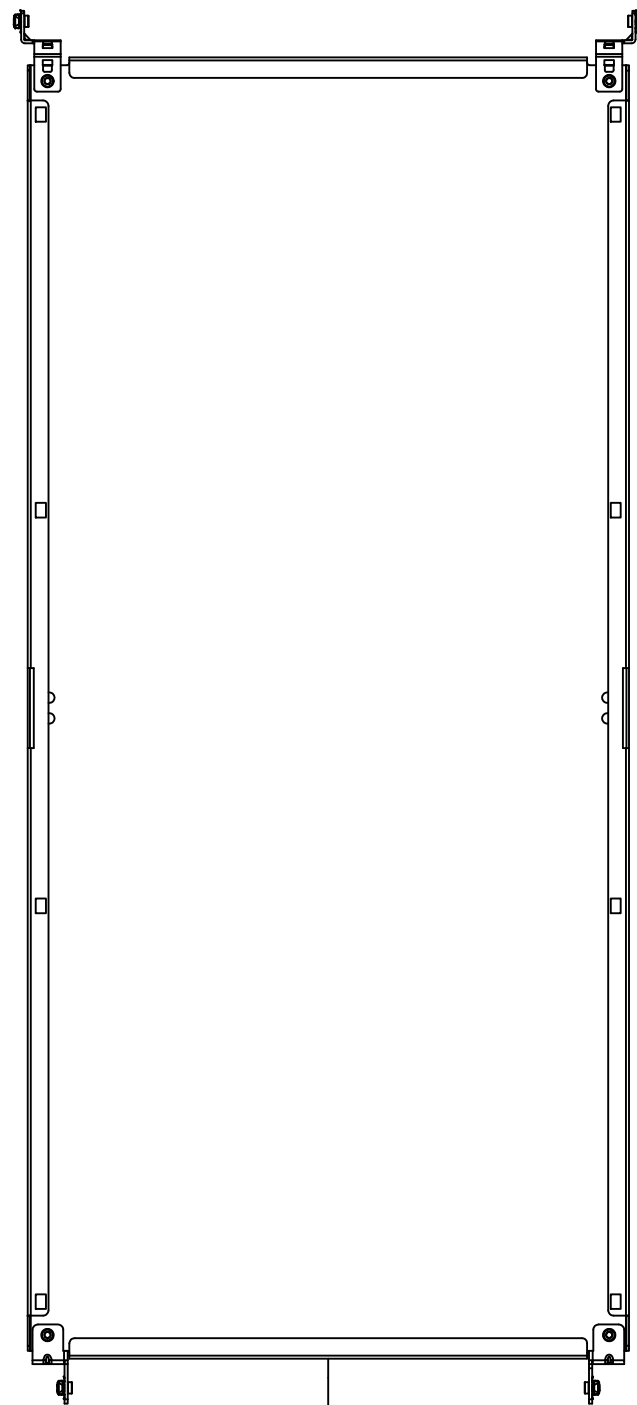

BACK



BOTTOM

0.0
26.0

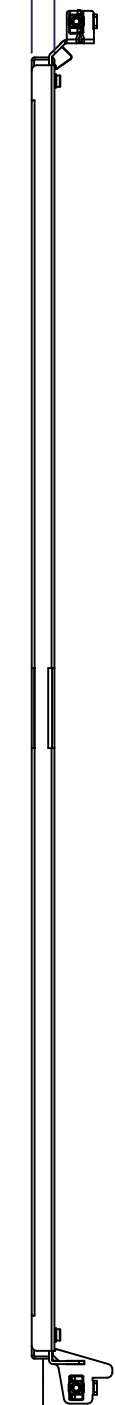

LEFT

0.0

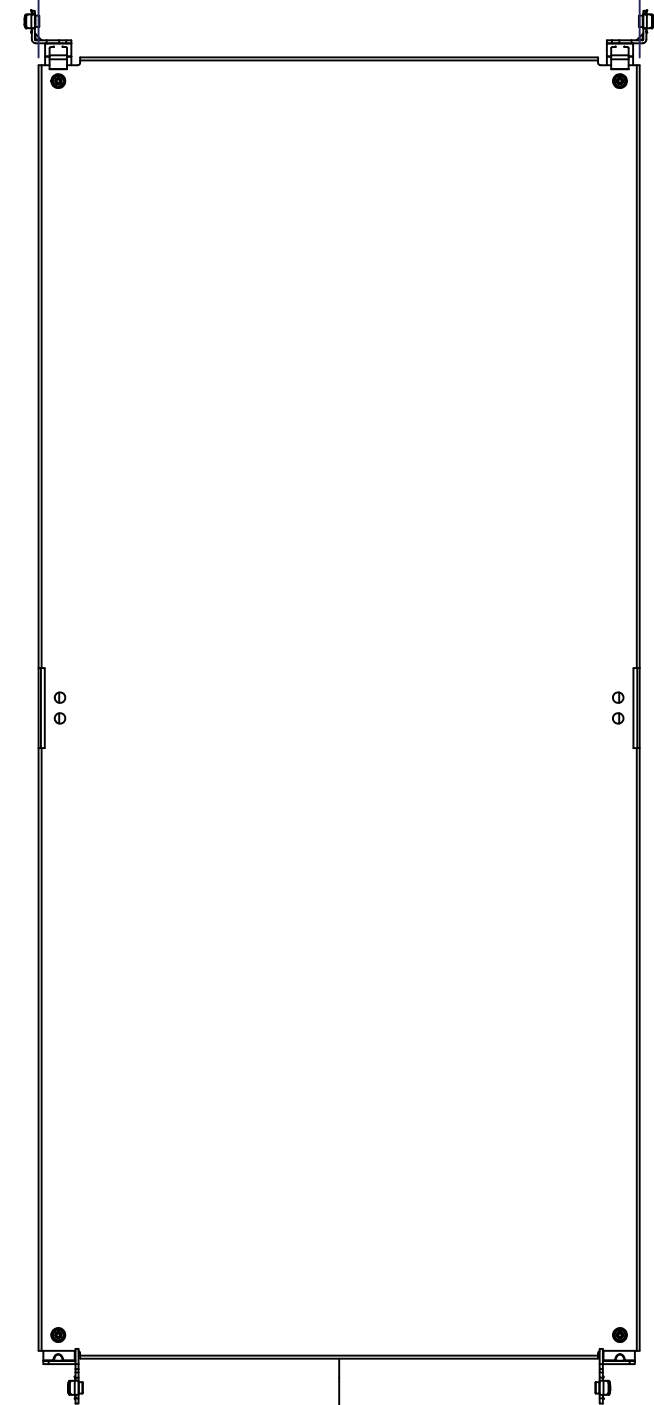

FRONT

1480.0

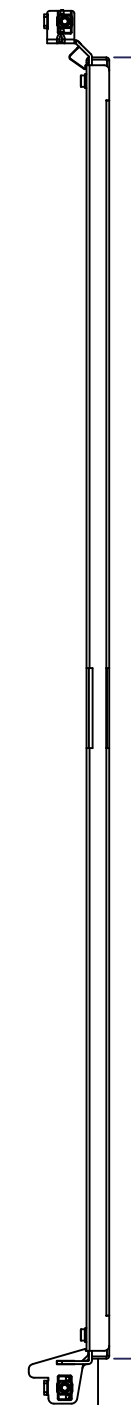

RIGHT

No.	Revisions	Date	By/Par

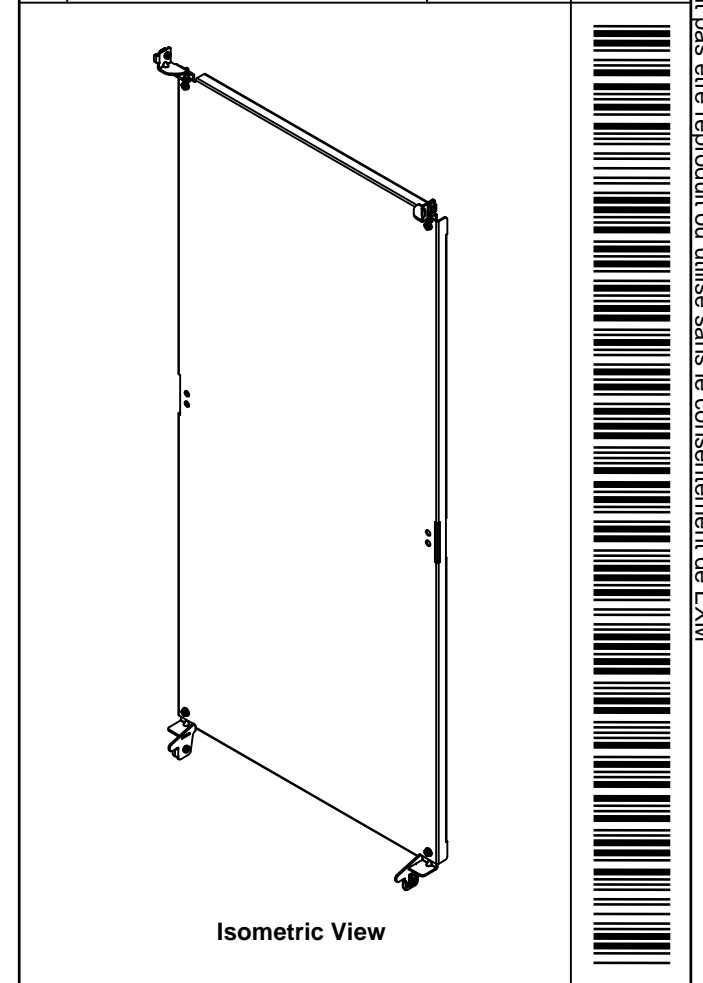

Isometric View

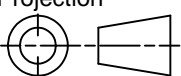

 Tél: (450) 979-4373 Fax: (450) 979-4626 www.exmweb.com		Flatness Aplatissement Max 3.0mm Projection 
Customer Client	Date	
Drawn By Dessiné Par	BoxCad: Annie	Date 04/02/2015
Material Matière	12 Ga Galvanized (2.5mm)	
Color Couleur	Unpainted	Finish Fini Unpainted
Description	Detail Rev.	
6500 MXM 1600mm x 800mm Back Inner Panel		
Part Number Numéro Pièce	Rev.	1
6500MXK160810BIP	0	3

SEE BILL OF MATERIAL ON LAST PAGE

This drawing is confidential and must not be reproduced or used without the consent of EXM

Ce dessin est confidentiel et ne doit pas être reproduit ou utilisé sans le consentement de EXM

No.	Revisions	Date	By/Par

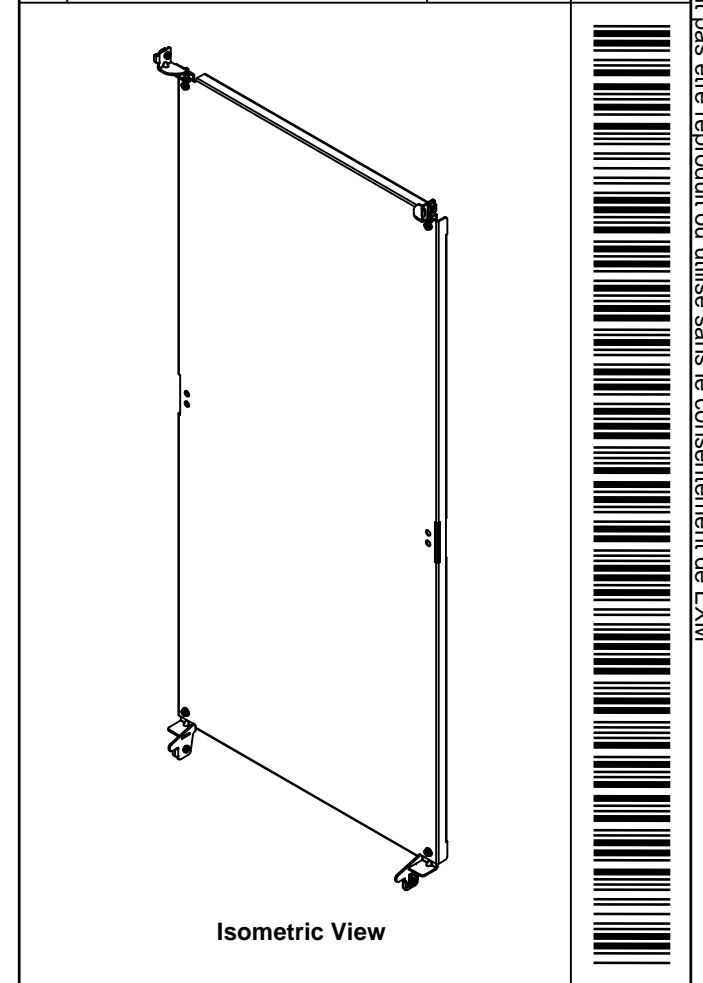

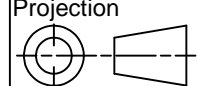
 Tél: (450) 979-4373 Fax: (450) 979-4626 www.exmweb.com		Flatness Aplatissement Max 3.0mm Projection 
Customer Client	Date	
Drawn By Dessiné Par	BoxCad: Annie	Date 04/02/2015
Material Matière	12 Ga Galvanized (2.5mm)	
Color Couleur	Unpainted	Finish Fini Unpainted
Description	Detail Rev.	
6500 MXM 1600mm x 800mm Back Inner Panel		
Part Number Numéro Pièce	Rev. 3	3
6500MXK160810BIP	0	3

Qty	Part Number	Rev	Description
1	STK-A-49005	0	6500MXM - Bottom Inner Panel Support Kit (Right)
1	STK-A-49000	0	6500MXM - Bottom Inner Panel Support Kit (Left)
1	STK-A-49015	0	6500MXM - Top Inner Panel Support Kit (Right)
1	STK-A-49010	0	6500MXM - Top Inner Panel Support Kit (Left)
1	6500MXK160810BIP-P	0	6500 MXM 1600mm x 800mm Back Inner Panel Part
Parts List			