

This drawing is confidential and must not be reproduced or used without the consent of EXM

Ce dessin est confidentiel et ne doit pas être reproduit ou utilisé sans le consentement de EXM

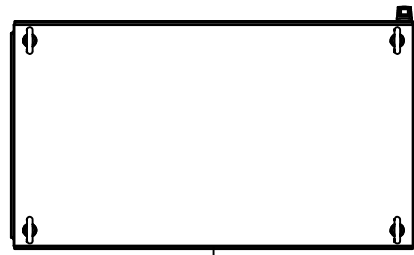

TOP

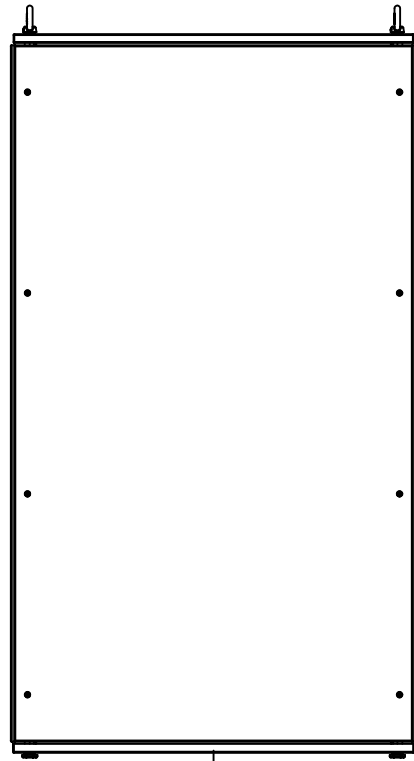

BACK

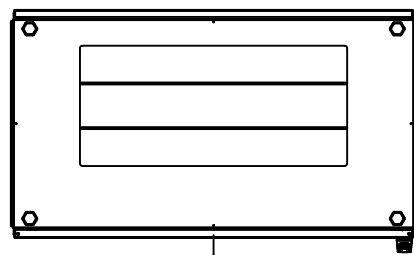

BOTTOM

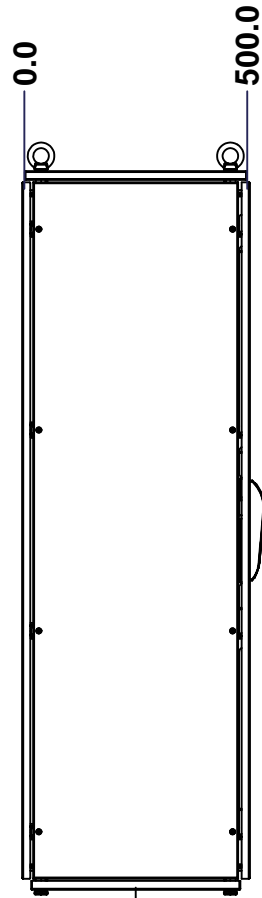

LEFT

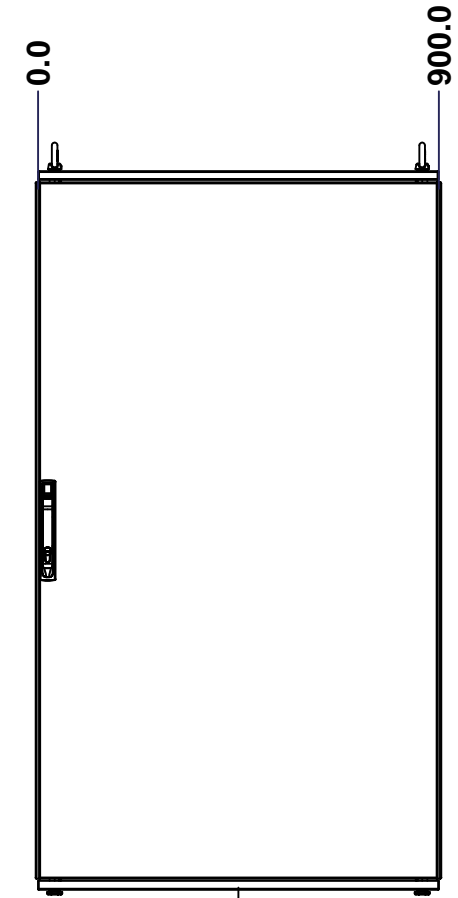

FRONT

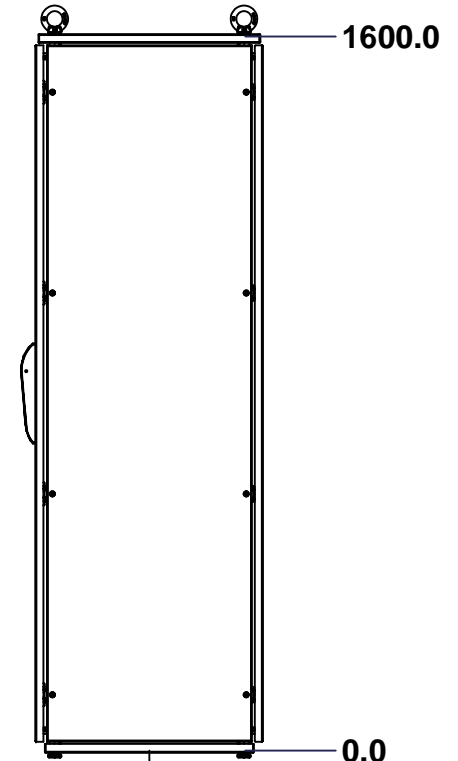

RIGHT

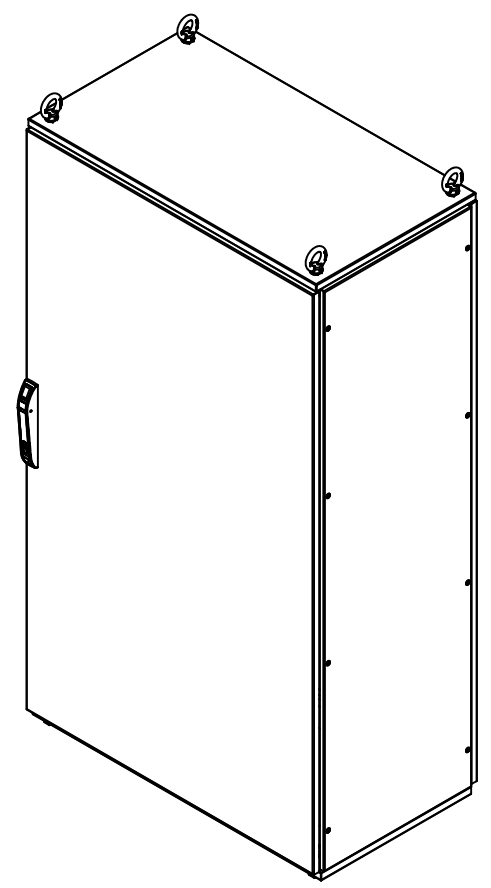

Isometric View

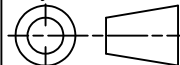

No.	Revisions	Date	By/Par

 Tél: (450) 979-4373 Fax: (450) 979-4626 <a href="http://www.exmweb.com">www.exmweb.com</a>		Flatness Aplatissement Max 3.0mm Projection 
Customer Client	Date	Date
Drawn By Dessiné Par	BoxCad: Annie	Date 05/02/2015
Material Matière	See Part List	
Color Couleur	See Part List	Finish Fini See Part List
Description	Detail Rev.	
6500MX 1600mm x 900mm x 500mm Assembly		
Part Number Numéro Pièce	Rev.	
6500MXK160905	0	1 2

SEE BILL OF MATERIAL ON LAST PAGE

This drawing is confidential and must not be reproduced or used without the consent of EXM

Ce dessin est confidentiel et ne doit pas être reproduit ou utilisé sans le consentement de EXM

No.	Revisions	Date	By/Par

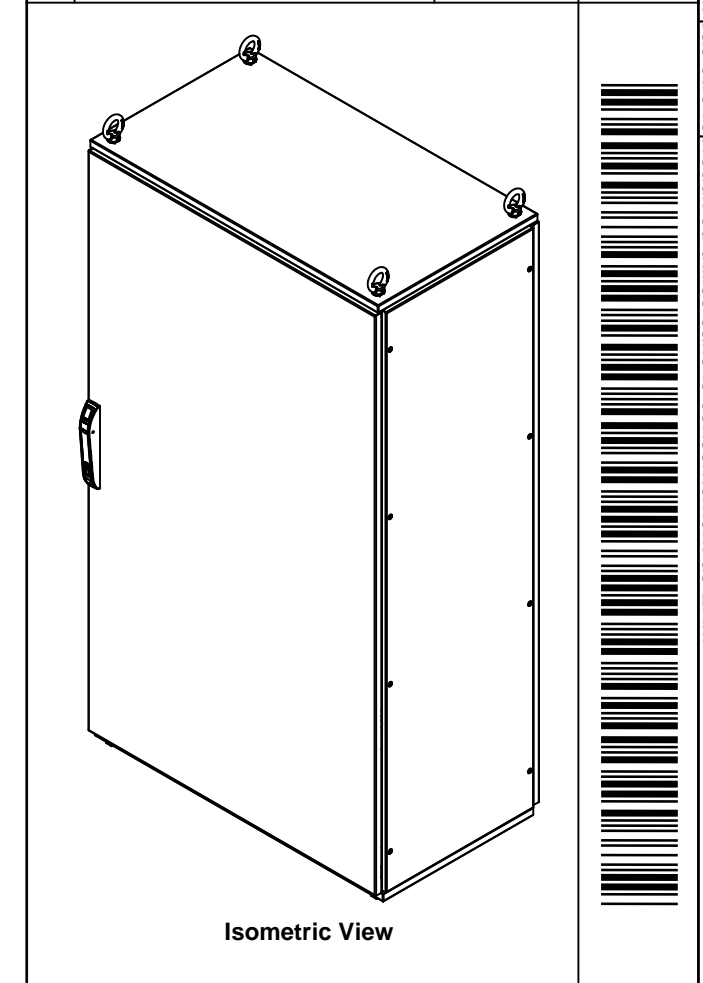

Tél: (450) 979-4373 Fax: (450) 979-4626 <a href="http://www.exmweb.com">www.exmweb.com</a>		Flatness Aplatissement
		Max 3.0mm
Customer Client		Date
Drawn By Dessiné Par BoxCad: Annie		Date 05/02/2015
Material Matière		See Part List
Color Couleur	See Part List	Finish Finis See Part List
Description 6500MX 1600mm x 900mm x 500mm Assembly		Detail Rev.
Part Number Numéro Pièce		Rev. 2
<b>6500MXK160905</b>		<b>0</b>

Qty	Part Number	Rev	Description
1	6500MXK160905BIP	0	6500 MXM 1600mm x 900mm Back Inner Panel
1	6500MXK160905R	0	6500 MXC 1600mm x 500mm Right
1	6500MXK160905L	0	6500 MXC 1600mm x 500mm Left
1	6500MXK160905F	0	6500 MXD 1600mm x 900mm Front
1	6500MXK160905B	0	6500 MXR 1600mm x 900mm Back
1	6500MXK160905BT	0	6500 MXB 900mm x 500mm Bottom
1	6500MXK160905T	0	6500 MXT 900mm x 500mm Top
1	6500MXK160905FR	0	6500 MX 1600mm x 900mm x 500mm Frame
Parts List			

This drawing is confidential and must not be reproduced or used without the consent of EXM

Ce dessin est confidentiel et ne doit pas être reproduit ou utilisé sans le consentement de EXM



TOP

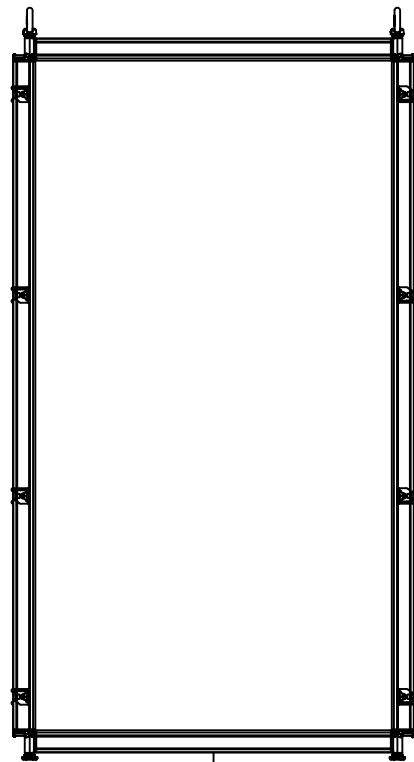

BACK



BOTTOM

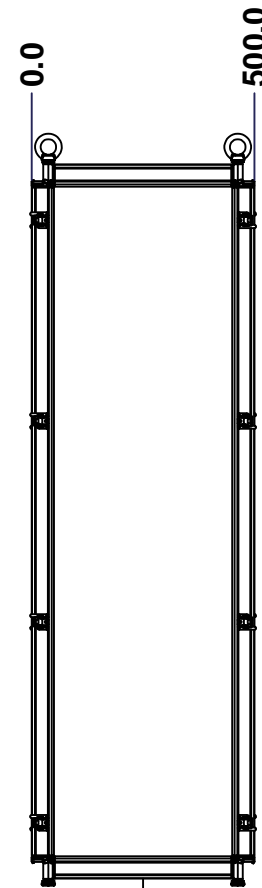

LEFT

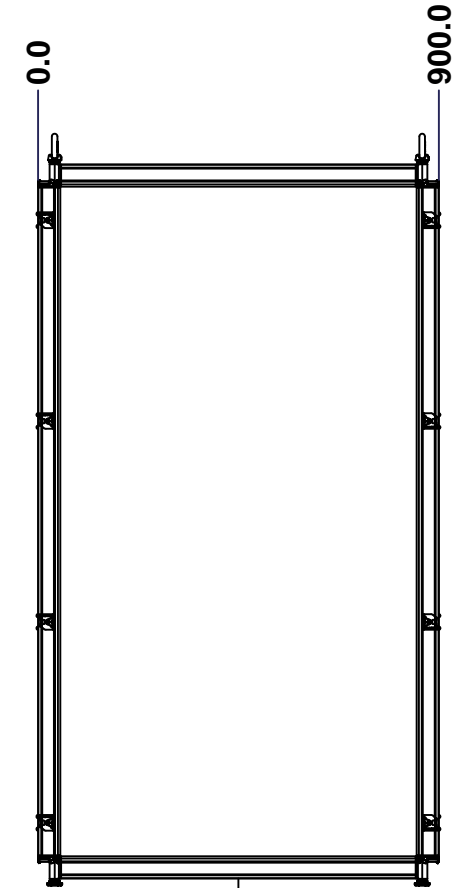

FRONT

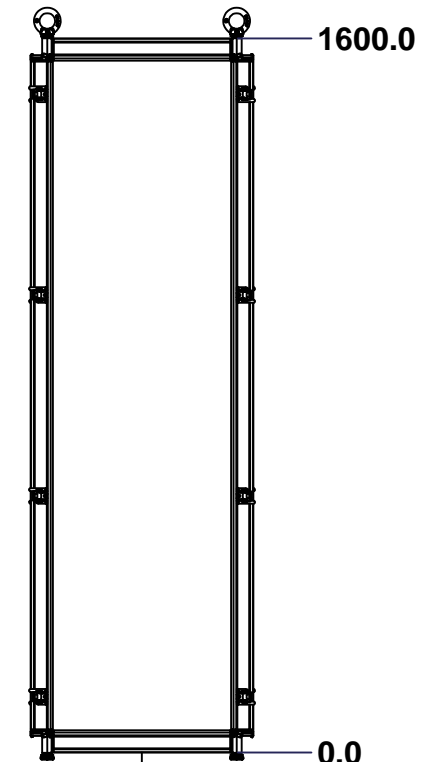

RIGHT

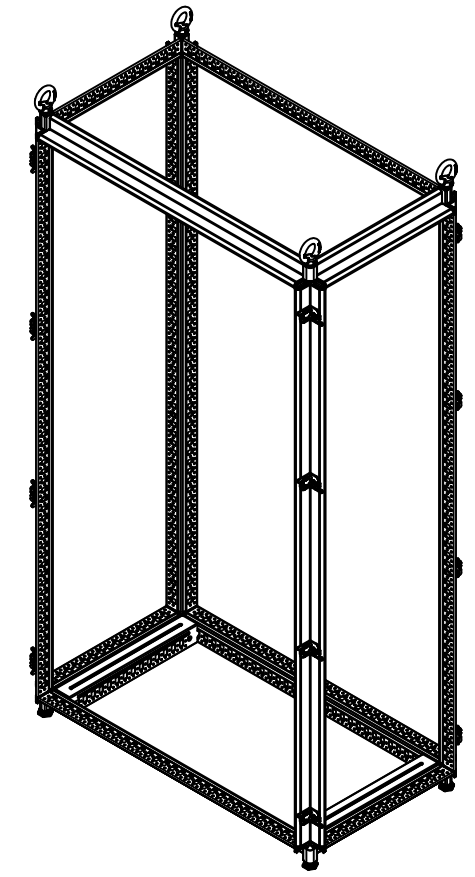

Isometric View

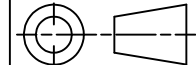

No.	Revisions	Date	By/Par

 Tél: (450) 979-4373 Fax: (450) 979-4626 <a href="http://www.exmweb.com">www.exmweb.com</a>		Flatness Aplatissement Max 3.0mm Projection 
Customer Client	Date	
Drawn By Dessiné Par	BoxCad: Annie	Date 05/02/2015
Material Matière	16 Ga Electro-Galvanized (1.4mm)	
Color Couleur	Iron Grey RAL7011	Finish Fin Rough Textured
Description	Detail Rev.	
6500 MX 1600mm x 900mm x 500mm Frame		
Part Number Numéro Pièce	Rev.	1 2
<b>6500MXK160905FR</b>	<b>0</b>	

SEE BILL OF MATERIAL ON LAST PAGE

This drawing is confidential and must not be reproduced or used without the consent of EXM

Ce dessin est confidentiel et ne doit pas être reproduit ou utilisé sans le consentement de EXM

No.	Revisions	Date	By/Par

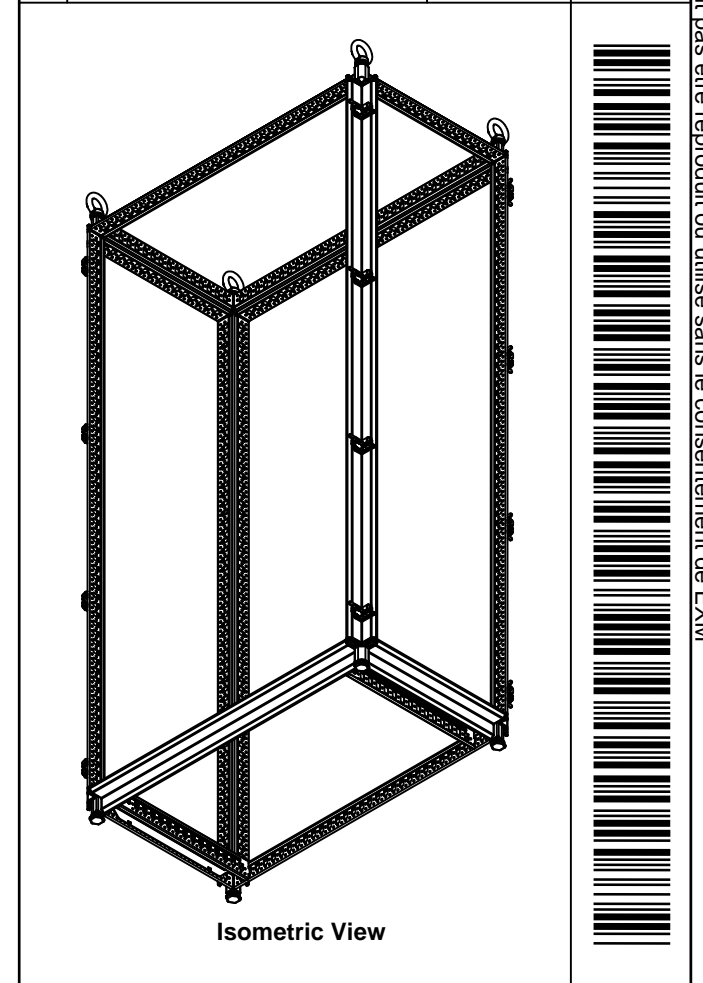

1	STK-P-03810R	0	Powder Paint (Iron Grey / Rough Textured)
1	STK-Q-49055	3	6500 MXM Inner Panel Slider 500mm
1	STK-Q-49055-L	3	6500 MXM Inner Panel Slider 500mm
4	STK-Q-49500	3	M12 Eye Bolt (0.34T)
4	STK-Q-61110	0	M12 Feet Leveler
8	STK-Q-00610	1	M18 x 30.5mm Bolt - Cover
4	STK-Q-47251-16	3	6500 MX 1600mm Vertical Frame Post Part
4	STK-Q-47250-09	3	6500 MX 900mm Horizontal Frame Post Part
4	STK-Q-47250-05	3	6500 MX 500mm Horizontal Frame Post Part
8	STK-Q-49445	2	6500 MX - Frame Corner Bracket Casting
16	STK-K-11001	2	3 Way Fixed Bracket Kit
Qty	Part Number	Rev	Description
Parts List			



Tél: (450) 979-4373  
Fax: (450) 979-4626  
[www.exmweb.com](http://www.exmweb.com)

Flatness  
Aplatissement  
Max 3.0mm

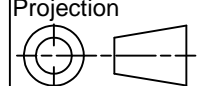
Projection  

Customer Client		Date
Drawn By / Dessiné Par: BoxCad: Annie		Date: 05/02/2015
Material / Matière: 16 Ga Electro-Galvanized (1.4mm)		
Color / Couleur: Iron Grey RAL7011	Finish / Fini: Rough Textured	
Description: 6500 MX 1600mm x 900mm x 500mm Frame		Detail Rev.
Part Number / Numéro Pièce: <b>6500MXK160905FR</b>		Rev. 2
		<b>0</b>

This drawing is confidential and must not be reproduced or used without the consent of EXM

Ce dessin est confidentiel et ne doit pas être reproduit ou utilisé sans le consentement de EXM



TOP

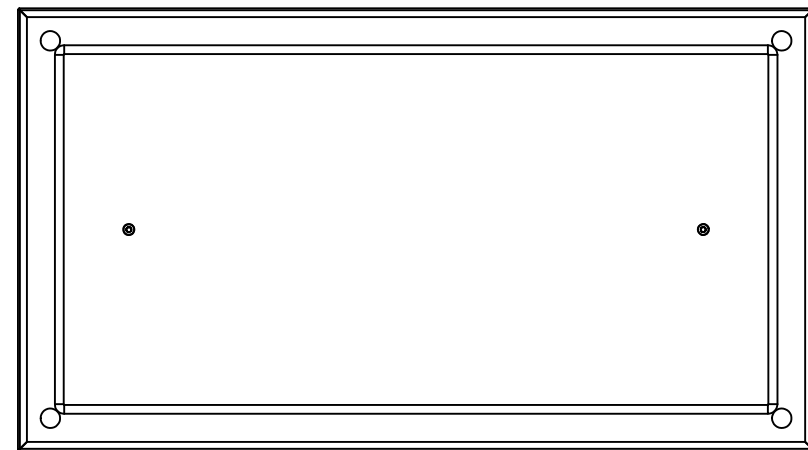

BACK

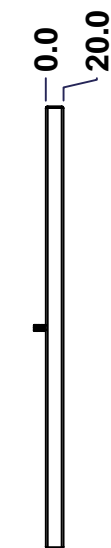

LEFT

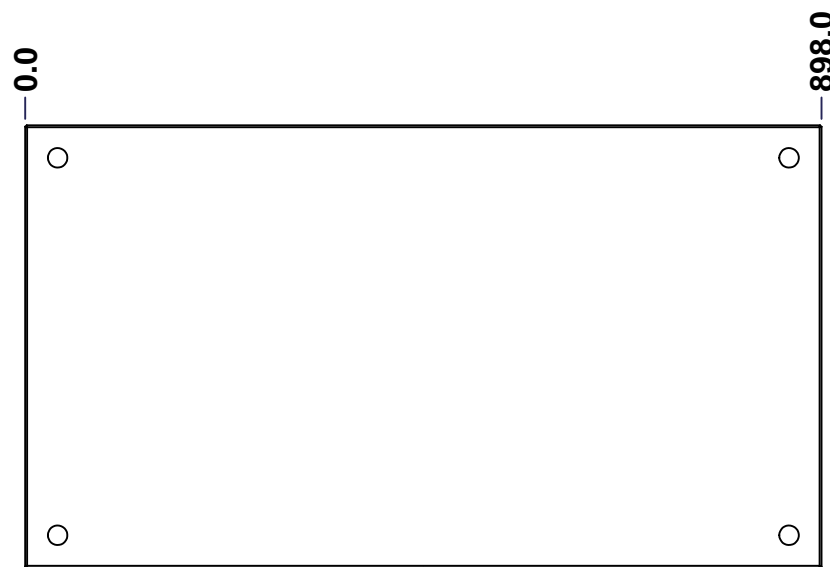

FRONT

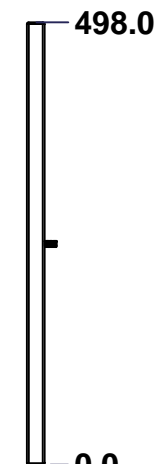

RIGHT

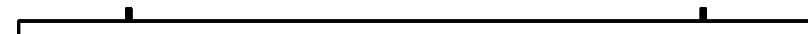

BOTTOM

No.	Revisions	Date	By/Par

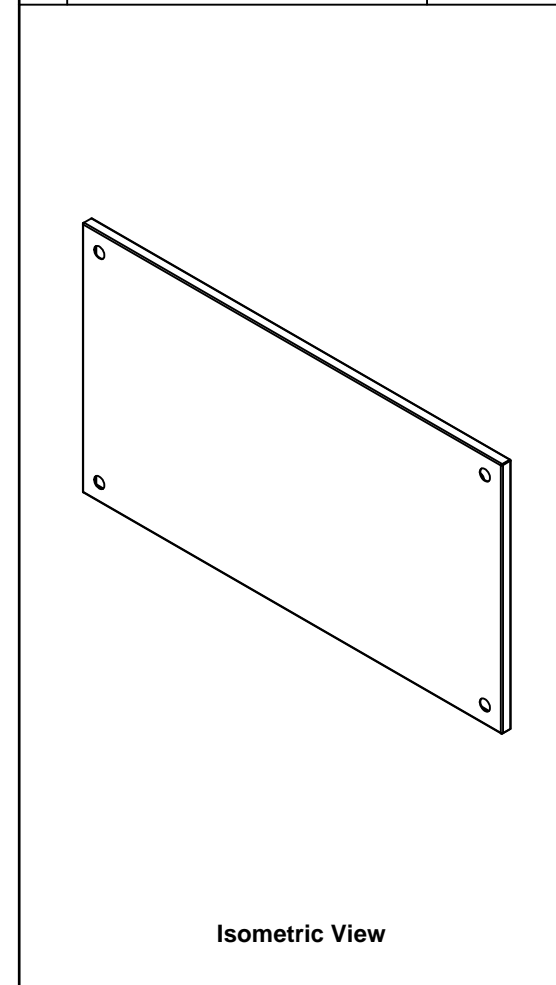

Isometric View

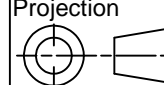

 Tél: (450) 979-4373 Fax: (450) 979-4626 <a href="http://www.exmweb.com">www.exmweb.com</a>		Flatness Aplatissement Max 3.0mm Projection 
Customer Client	Date	
Drawn By / Dessiné Par: BoxCad: Annie	Date: 05/02/2015	
Material / Matière: 16 Ga H.R.P. & O. (1.4mm)		
Color / Couleur: Iron Grey RAL7011	Finish / Fini: Rough / Textured	
Description: 6500 MXT 900mm x 500mm Top		Detail Rev.
Part Number / Numéro Pièce: 6500MXK160905T	Rev. 0	1 / 3

SEE BILL OF MATERIAL ON LAST PAGE

This drawing is confidential and must not be reproduced or used without the consent of EXM

Ce dessin est confidentiel et ne doit pas être reproduit ou utilisé sans le consentement de EXM

STANDARD FEATURES ARE NOT LISTED IN THIS HOLE TABLE			
HOLE TABLE - FRONT VIEW (CUSTOM FEATURE ONLY)			
CUT-OUT	XDIM	YDIM	DESCRIPTION
1	125.0	249.0	GND STUD M6 x 16mm (Inside)
2	773.0	249.0	GND STUD M6 x 16mm (Inside)

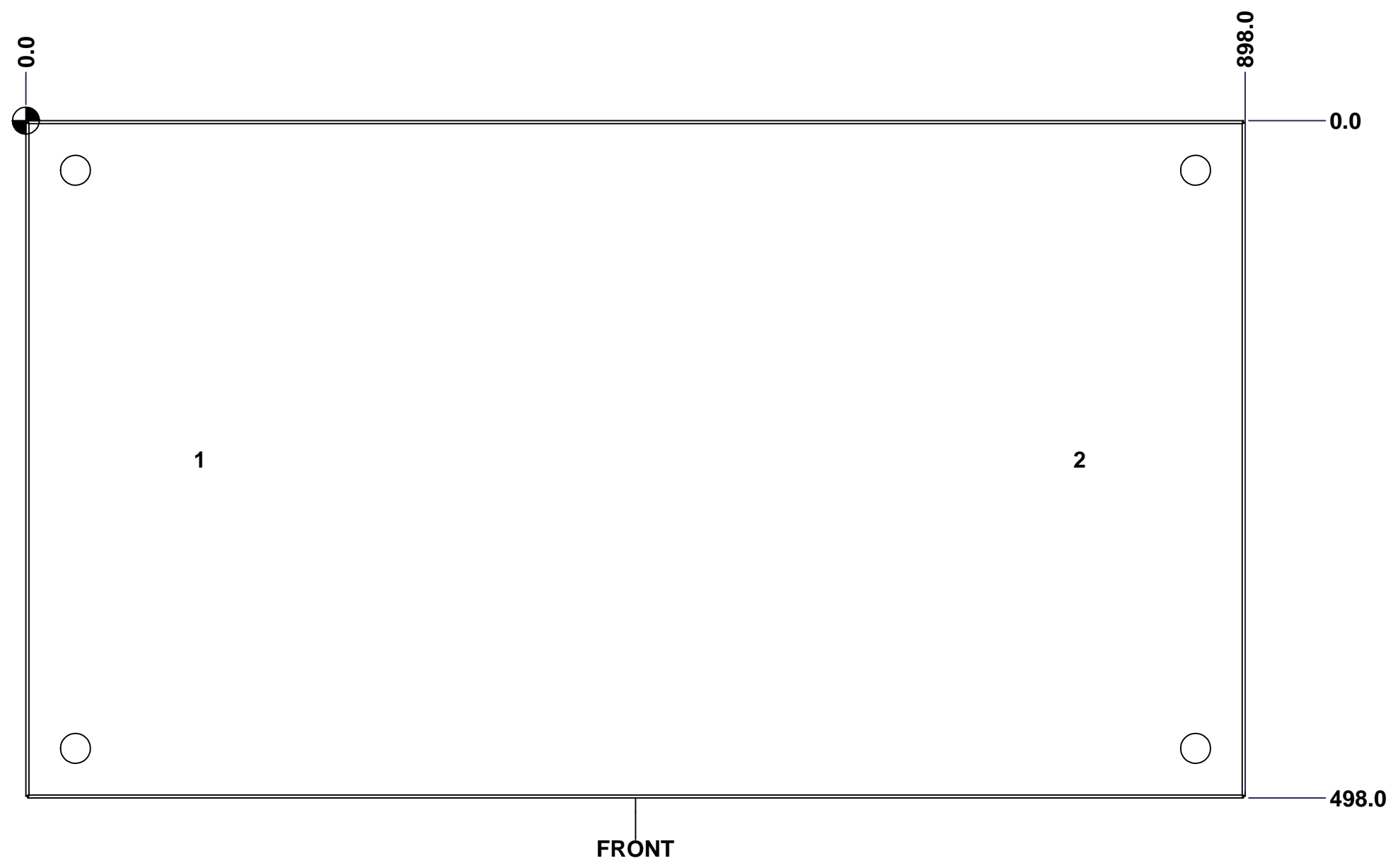



	Description		Status
	6500 MXT 900mm x 500mm Top		(NULL)
Part Number Numéro Pièce		Rev.	2
<b>6500MXK160905T</b>		<b>0</b>	3

This drawing is confidential and must not be reproduced or used without the consent of EXM

Ce dessin est confidentiel et ne doit pas être reproduit ou utilisé sans le consentement de EXM

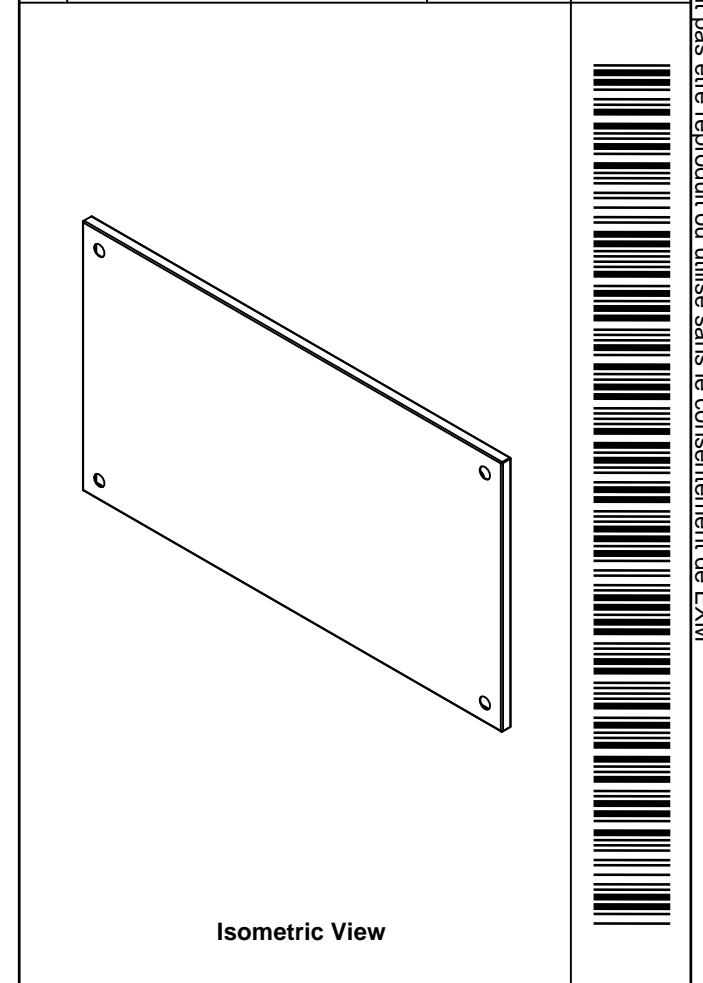
No.	Revisions	Date	By/Par

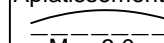
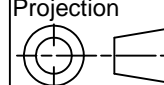

 Tél: (450) 979-4373 Fax: (450) 979-4626 <a href="http://www.exmweb.com">www.exmweb.com</a>		Flatness Aplatissement  Max 3.0mm Projection 
Customer Client	Date	
Drawn By Dessiné Par	BoxCad: Annie	Date 05/02/2015
Material Matière	16 Ga H.R.P. & O. (1.4mm)	
Color Couleur	Iron Grey RAL7011	Finish Fini Rough Textured
Description	Detail Rev.	
6500 MXT 900mm x 500mm Top		
Part Number Numéro Pièce	Rev.	3
<b>6500MXK160905T</b>	<b>0</b>	<b>3</b>

Qty	Part Number	Rev	Description
1	STK-P-03810R	0	Powder Paint (Iron Grey / Rough Textured)
2	STK-Q-16080	0.1.1	M6 x 16mm Ground Stud
1	6500MXK160905TG	0	6500 MXT 900mm x 500mm Top Gasket
1	6500MXK160905T-P	0	6500 MXT 900mm x 500mm Top Part
Parts List			

This drawing is confidential and must not be reproduced or used without the consent of EXM

Ce dessin est confidentiel et ne doit pas être reproduit ou utilisé sans le consentement de EXM

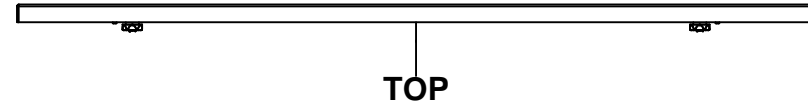

TOP

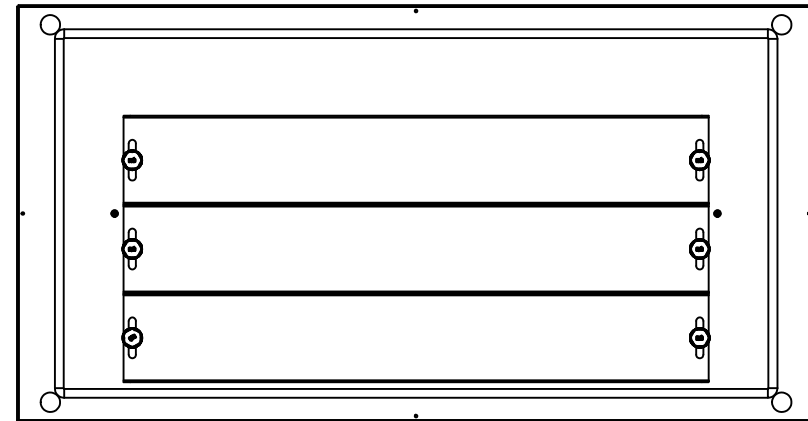

BACK

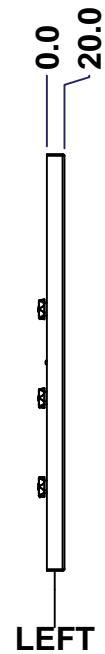

LEFT

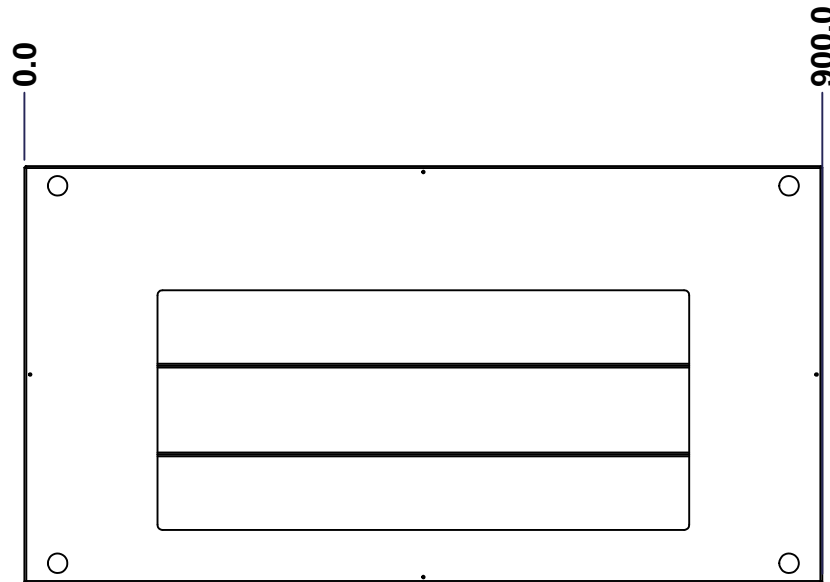

FRONT

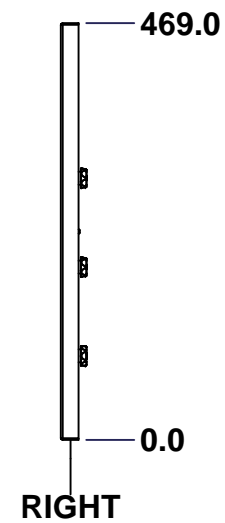

RIGHT



BOTTOM

No.	Revisions	Date	By/Par

**Isometric View**

Tél: (450) 979-4373 Fax: (450) 979-4626 <a href="http://www.exmweb.com">www.exmweb.com</a>		Flatness Aplatissement	
		Max 3.0mm	
Customer Client		Date	
Drawn By Dessiné Par BoxCad: Annie		Date 05/02/2015	
Material Matière 16 Ga H.R.P. & O. (1.4mm)			
Color Couleur Iron Grey RAL7011		Finish Fini Rough Textured	
Description 6500 MXB 900mm x 500mm Bottom			Detail Rev.
Part Number Numéro Pièce <b>6500MXK160905BT</b>		Rev. <b>0</b>	1 3

SEE BILL OF MATERIAL ON LAST PAGE



This drawing is confidential and must not be reproduced or used without the consent of EXM

Ce dessin est confidentiel et ne doit pas être reproduit ou utilisé sans le consentement de EXM

**STANDARD FEATURES ARE NOT LISTED IN THIS HOLE TABLE**

**HOLE TABLE - FRONT VIEW (CUSTOM FEATURE ONLY)**

CUT-OUT	XDIM	YDIM	DESCRIPTION
1	110.0	234.5	GND STUD M6 x 16mm (Inside)
2	790.0	234.5	GND STUD M6 x 16mm (Inside)
3	130.0	294.5	GP STUD M6 x 10mm (Inside)
4	770.0	294.5	GP STUD M6 x 10mm (Inside)
5	130.0	194.5	GP STUD M6 x 10mm (Inside)
6	770.0	194.5	GP STUD M6 x 10mm (Inside)
7	130.0	94.5	GP STUD M6 x 10mm (Inside)
8	770.0	94.5	GP STUD M6 x 10mm (Inside)

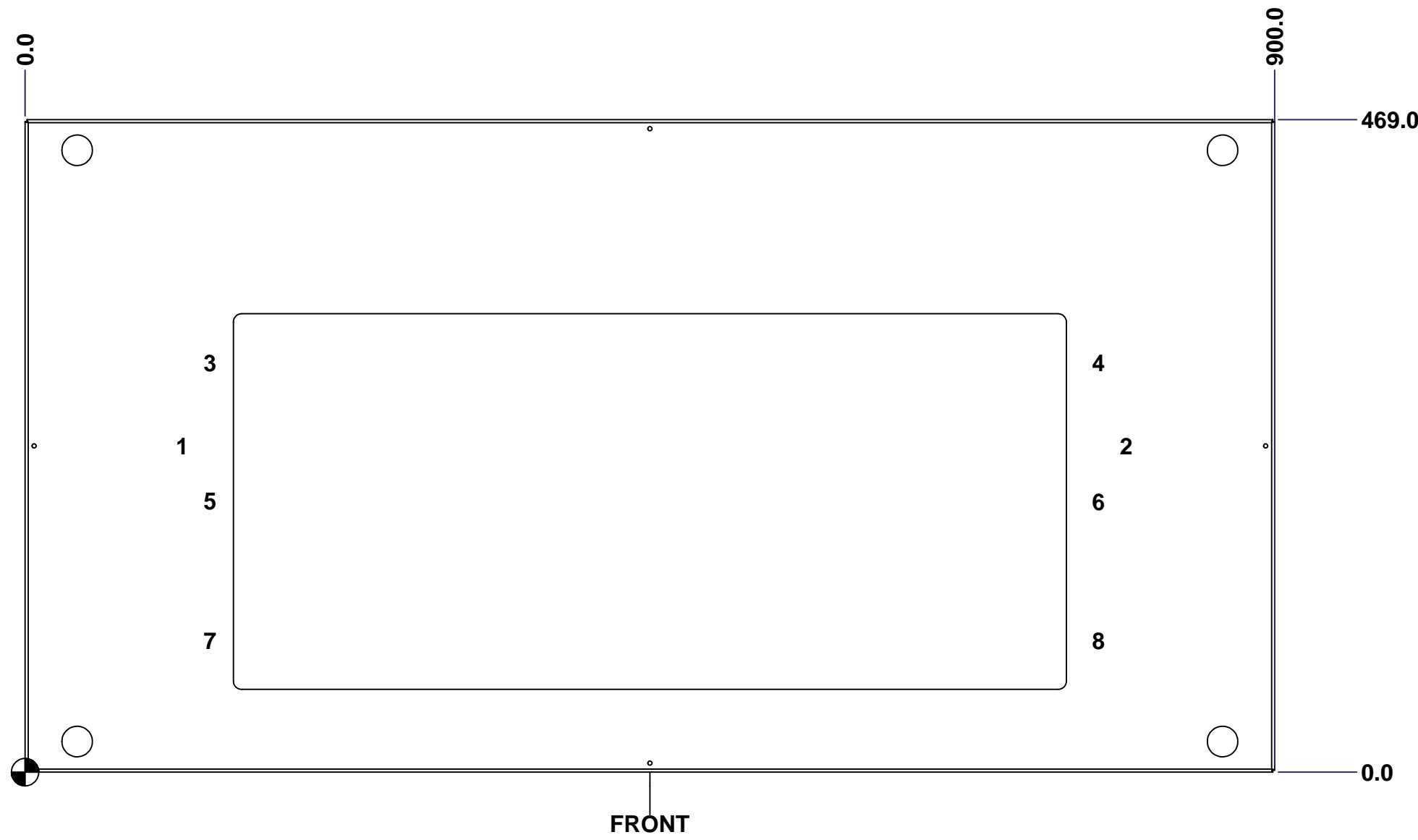

	Description	Status
	6500 MXB 900mm x 500mm Bottom	(NULL)
	Part Number Numéro Pièce	Rev.
	<b>6500MXK160905BT</b>	<b>0</b> / 2 / 3

This drawing is confidential and must not be reproduced or used without the consent of EXM

Ce dessin est confidentiel et ne doit pas être reproduit ou utilisé sans le consentement de EXM

No.	Revisions	Date	By/Par

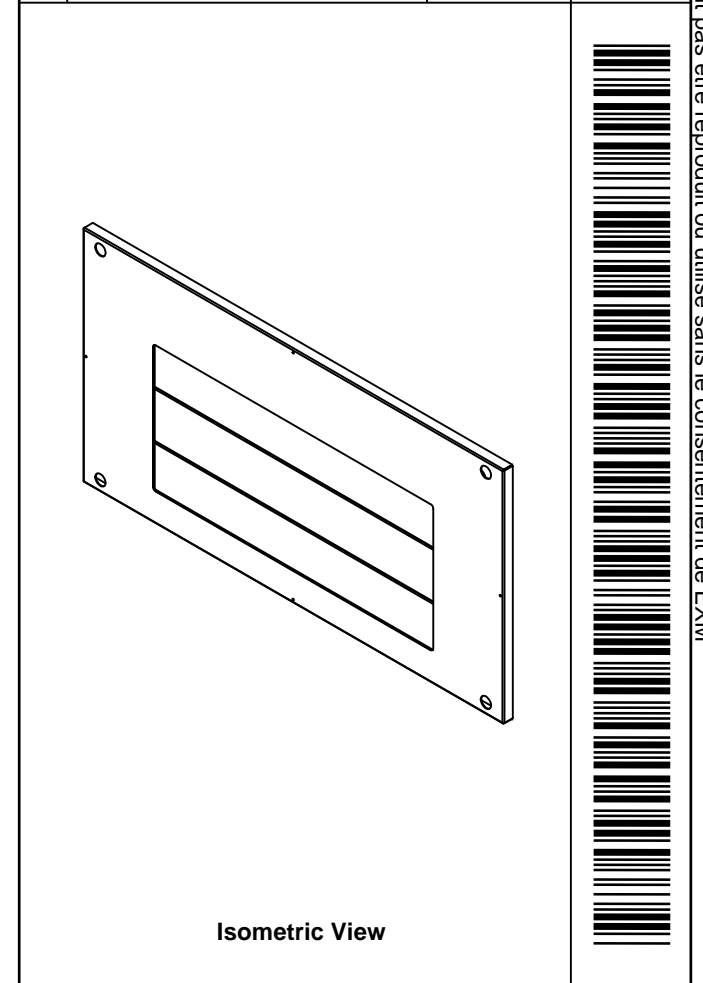

Tél: (450) 979-4373 Fax: (450) 979-4626 <a href="http://www.exmweb.com">www.exmweb.com</a>		Flatness Aplatissement	
		Max 3.0mm Projection	
Customer Client		Date	
Drawn By Dessiné Par BoxCad: Annie		Date 05/02/2015	
Material Matière		16 Ga H.R.P. & O. (1.4mm)	
Color Couleur Iron Grey RAL7011		Finish Fini Rough Textured	
Description 6500 MXB 900mm x 500mm Bottom			Detail Rev.
Part Number Numéro Pièce		Rev.	3
<b>6500MXK160905BT</b>		<b>0</b>	<b>3</b>

Qty	Part Number	Rev	Description
1	STK-P-03810R	0	Powder Paint (Iron Grey / Rough Textured)
6	STK-Q-06001	0	Mtrx - Gland Plate M6 Plastic Thumb Nut
2	STK-Q-16055	1	M6 x 18mm Stud (No Paint Cap Required)
3	6500MXK160905GP100-P	0	6500 MXB 900mm Gland Plate Part (100mm)
6	STK-Q-16031	0	M6 x 10mm Stud (No Paint Cap Required)
1	6500MXK160905BTGPG	0	6500 MXB 900mm x 500mm Bottom Gland Plate Gasket
1	6500MXK160905BTG	0	6500 MXB 900mm x 500mm Bottom Gasket
1	6500MXK160905BT-P	0	6500 MXB 900mm x 500mm Bottom Part
Parts List			

This drawing is confidential and must not be reproduced or used without the consent of EXM

Ce dessin est confidentiel et ne doit pas être reproduit ou utilisé sans le consentement de EXM

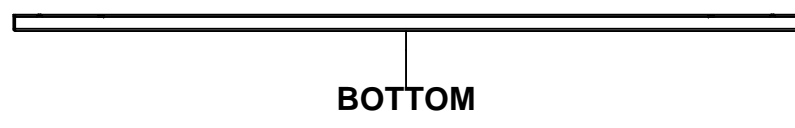
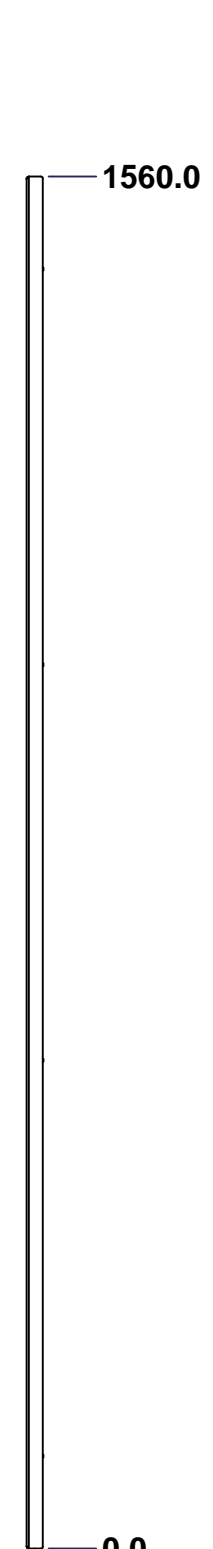
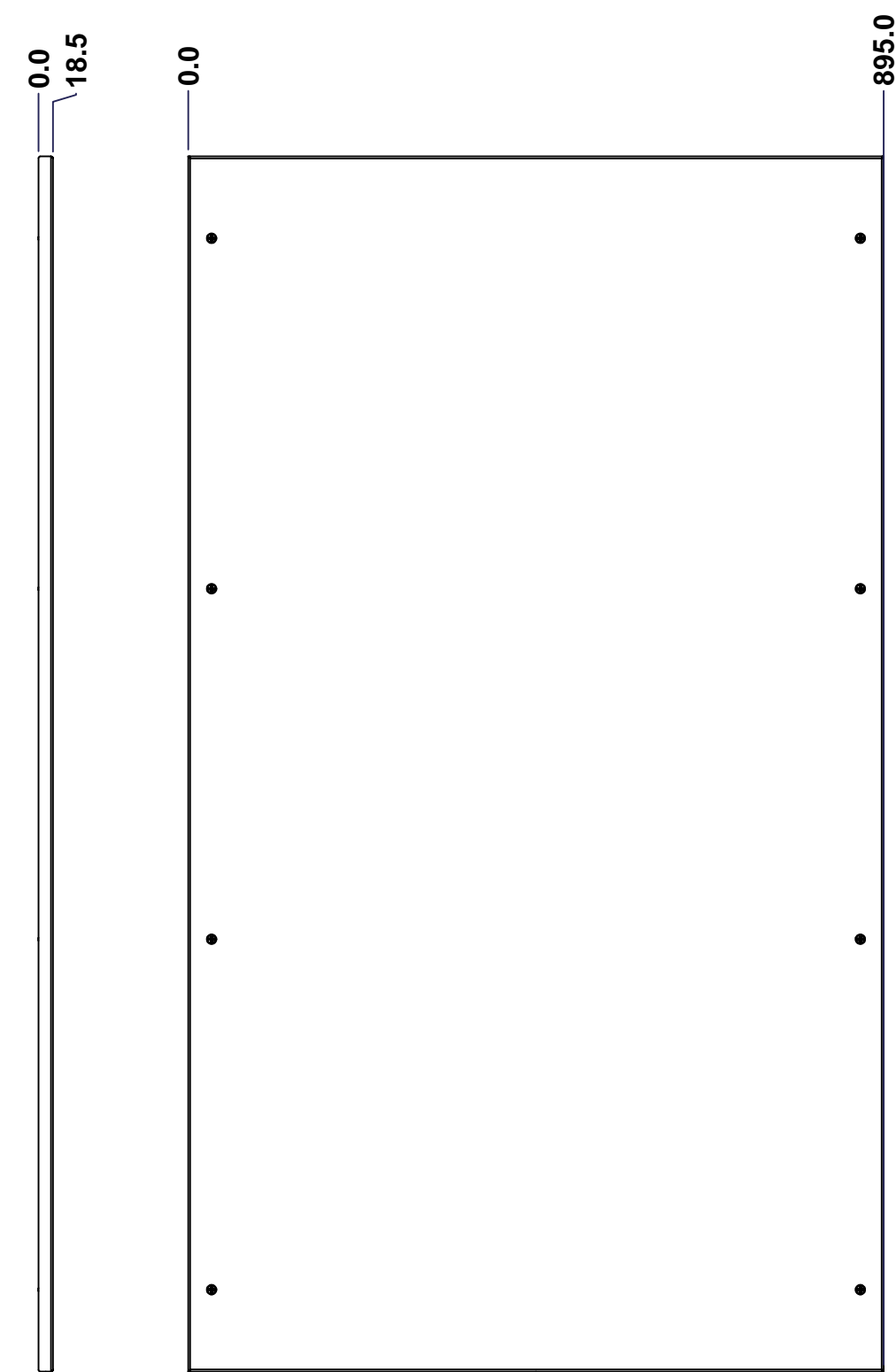
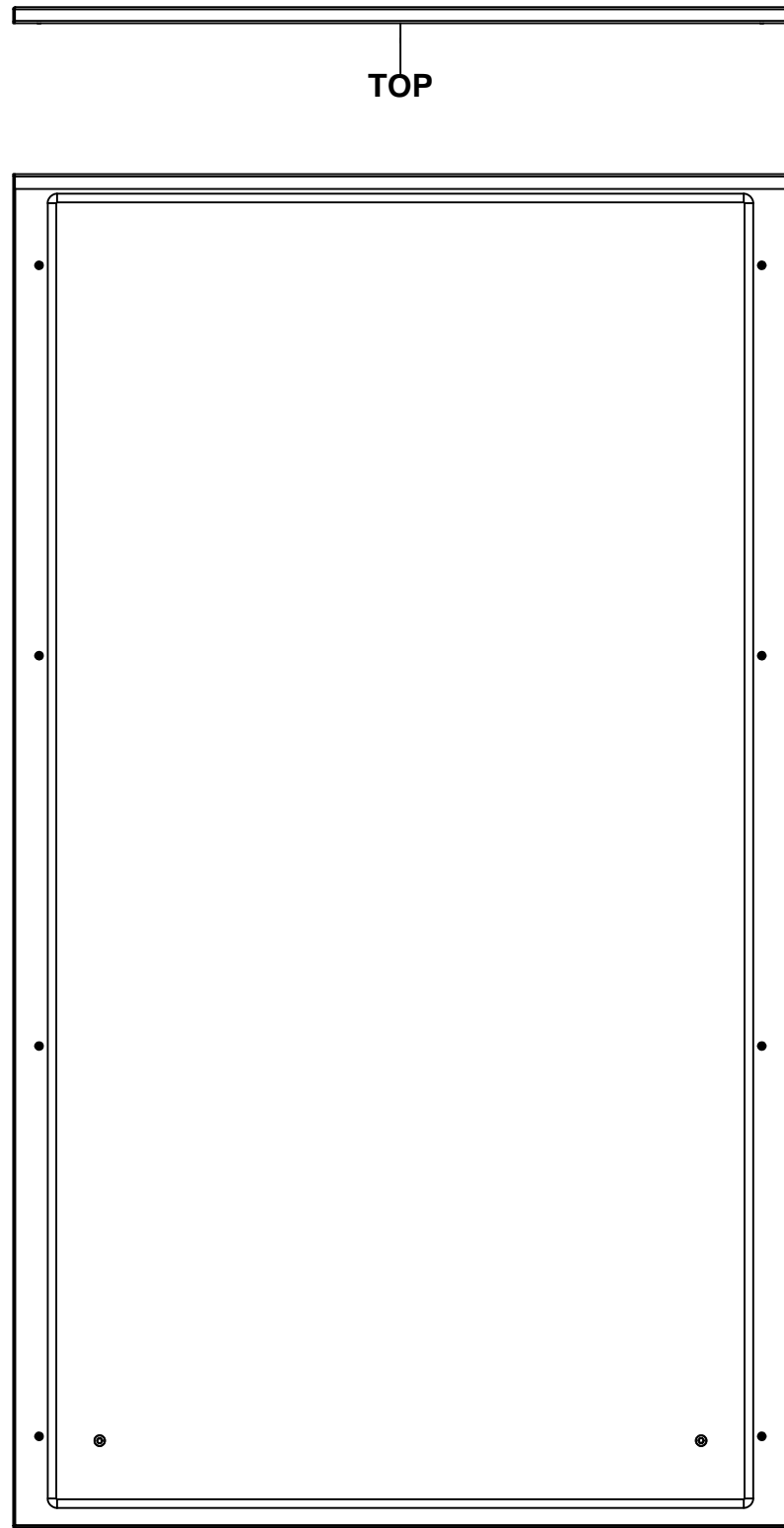

No.	Revisions	Date	By/Par

**Isometric View**

		Flatness Aplatissement Max 3.0mm	
Tél: (450) 979-4373 Fax: (450) 979-4626 <a href="http://www.exmweb.com">www.exmweb.com</a>		Projection 	
Customer Client		Date	
Drawn By Dessiné Par BoxCad: Annie		Date 05/02/2015	
Material Matière		14 Ga H.R.P. & O. (1.7mm)	
Color Couleur	Light Grey RAL7035	Finish Fini	Rough Textured
Description		Detail Rev.	
6500 MXR 1600mm x 900mm Back			
Part Number Numéro Pièce		Rev.	1 3
<b>6500MXK160905B</b>		<b>0</b>	

**SEE BILL OF MATERIAL ON LAST PAGE**

This drawing is confidential and must not be reproduced or used without the consent of EXM

Ce dessin est confidentiel et ne doit pas être reproduit ou utilisé sans le consentement de EXM

STANDARD FEATURES ARE NOT LISTED IN THIS HOLE TABLE			
HOLE TABLE - FRONT VIEW (CUSTOM FEATURE ONLY)			
CUT-OUT	XDIM	YDIM	DESCRIPTION
1	100.0	100.0	GND STUD M6 x 16mm (Inside)
2	795.0	100.0	GND STUD M6 x 16mm (Inside)

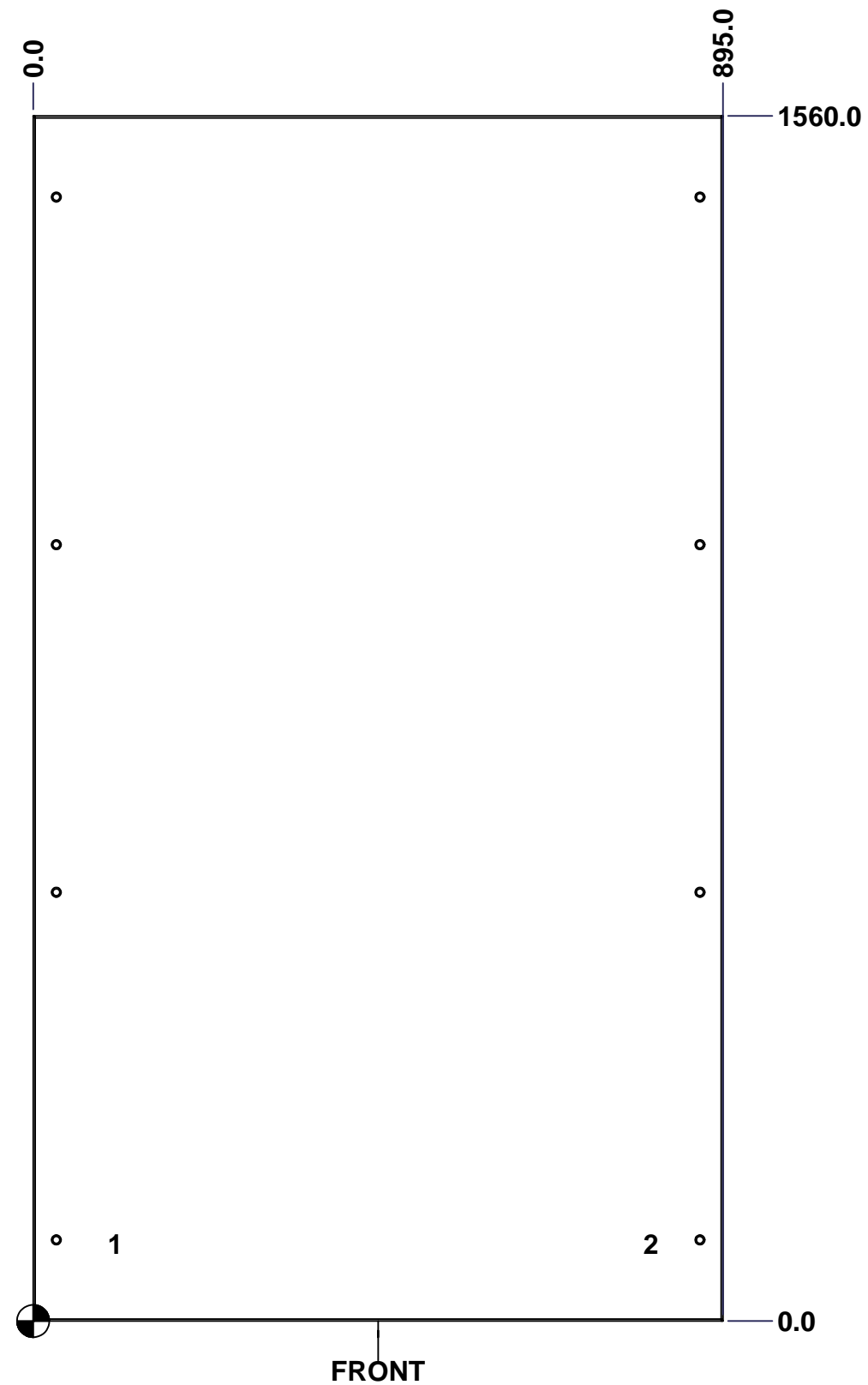

	Description	Status
	6500 MXR 1600mm x 900mm Back	(NULL)
Part Number Numéro Pièce <b>6500MXK160905B</b>	Rev.	2
	<b>0</b>	3

This drawing is confidential and must not be reproduced or used without the consent of EXM

Ce dessin est confidentiel et ne doit pas être reproduit ou utilisé sans le consentement de EXM

No.	Revisions	Date	By/Par

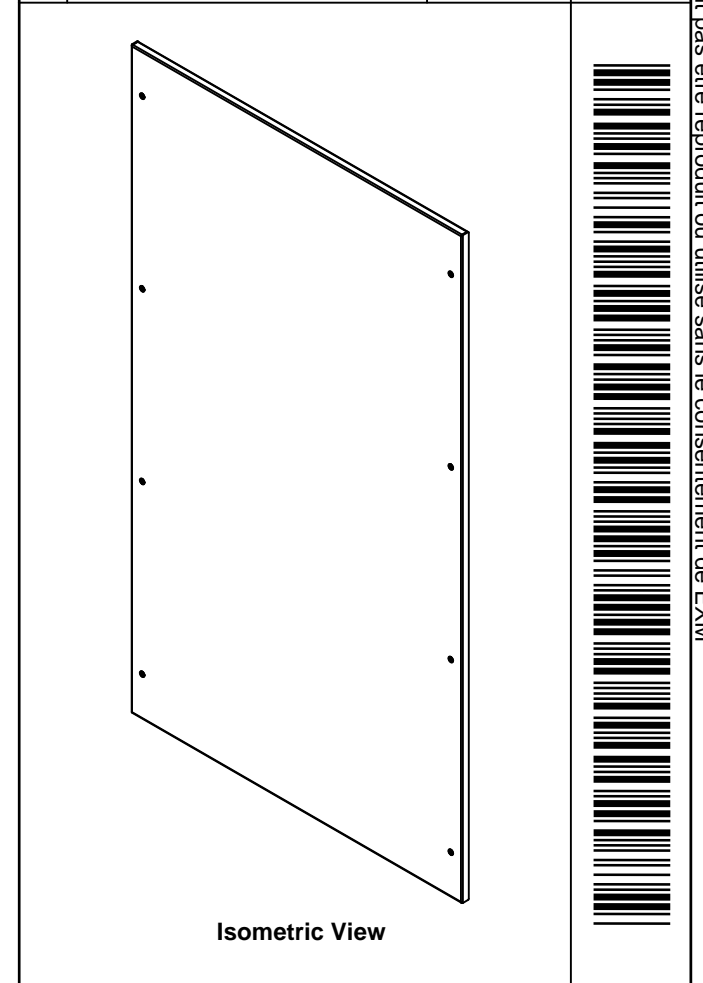

Tél: (450) 979-4373 Fax: (450) 979-4626 <a href="http://www.exmweb.com">www.exmweb.com</a>		Flatness Aplatissement	
		Max 3.0mm Projection	
Customer Client		Date	
Drawn By Dessiné Par BoxCad: Annie		Date 05/02/2015	
Material Matière 14 Ga H.R.P. & O. (1.7mm)			
Color Couleur Light Grey RAL7035		Finish Fini Rough Textured	
Description 6500 MXR 1600mm x 900mm Back			Detail Rev.
Part Number Numéro Pièce <b>6500MXK160905B</b>		Rev. <b>0</b>	3 3

Qty	Part Number	Rev	Description
1	STK-P-03820R	0	Powder Paint (Light Grey / Rough Textured)
8	STK-Q-03072	2	M6 x 17mm Phillips Flat Head Screw
2	STK-Q-16080	0.1.1	M6 x 16mm Ground Stud
1	6500MXK160905BG	0	6500 MXR 1600mm x 900mm Back Gasket
1	6500MXK160905B-P	0	6500 MXR 1600mm x 900mm Back Part
Parts List			

This drawing is confidential and must not be reproduced or used without the consent of EXM

Ce dessin est confidentiel et ne doit pas être reproduit ou utilisé sans le consentement de EXM



TOP

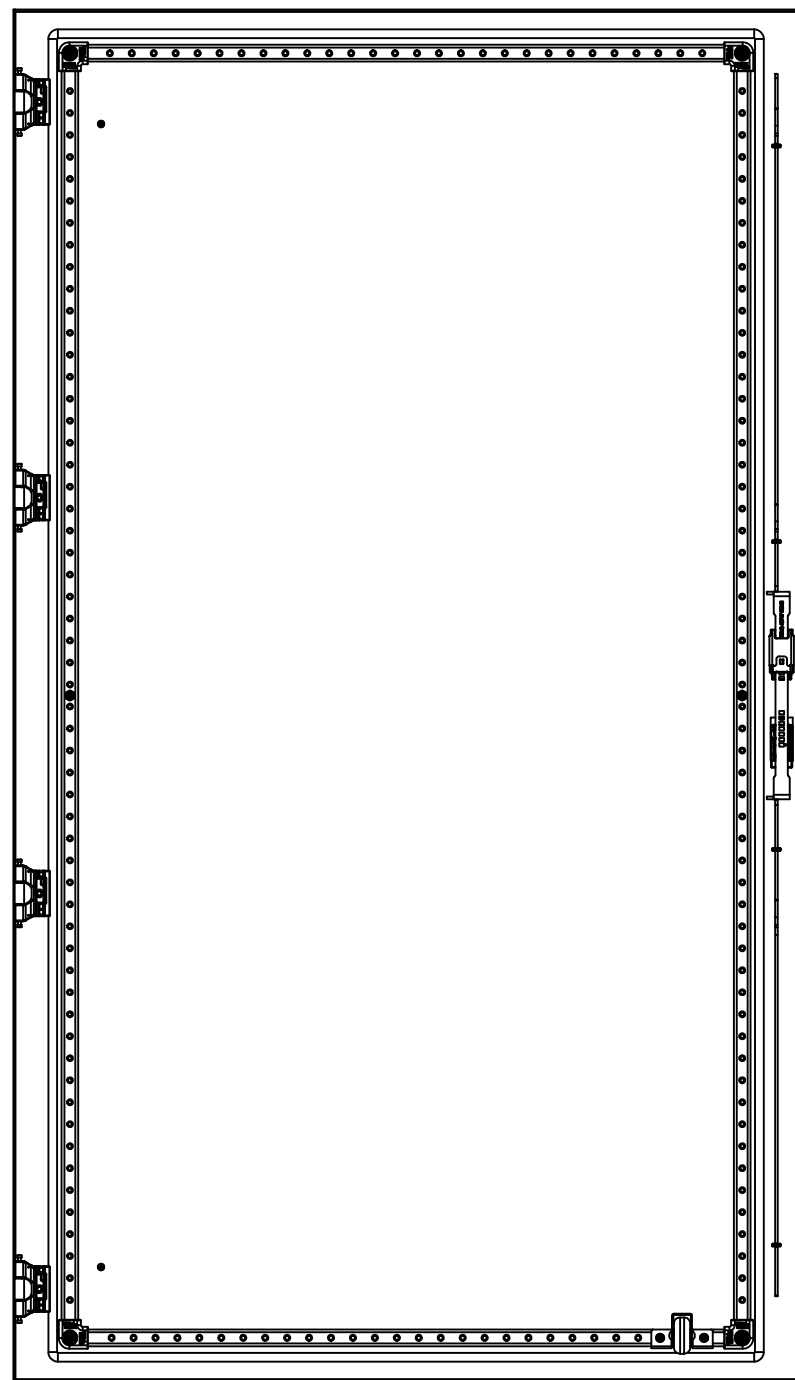

BACK



BOTTOM

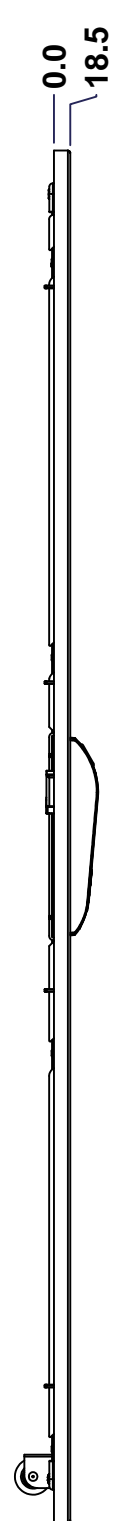

LEFT

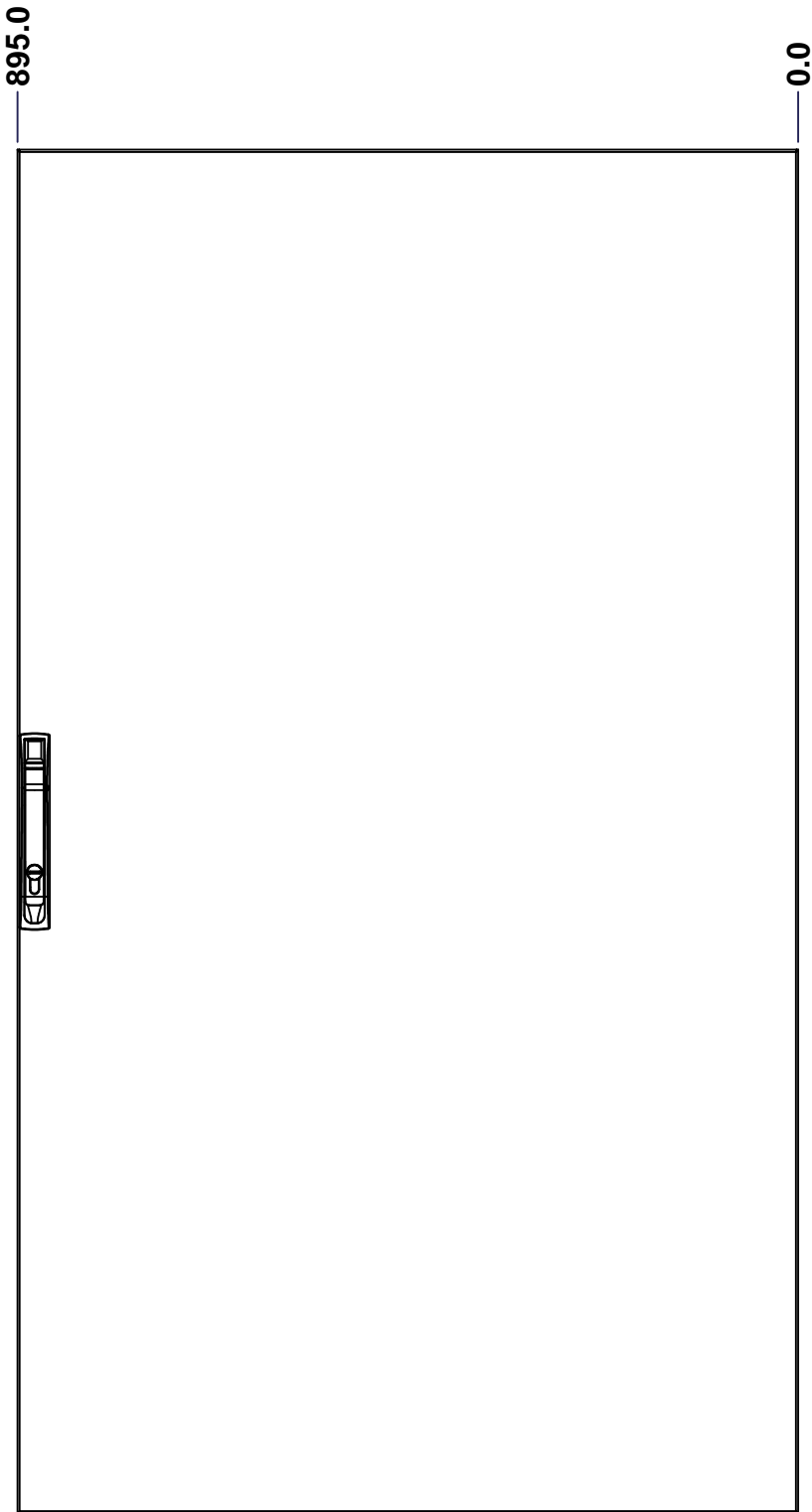

FRONT

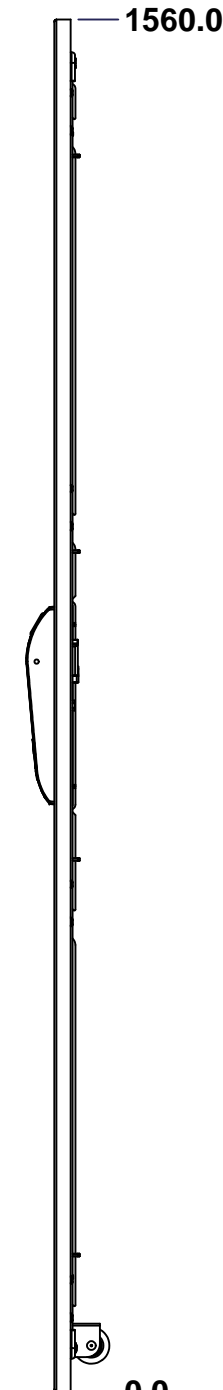

RIGHT

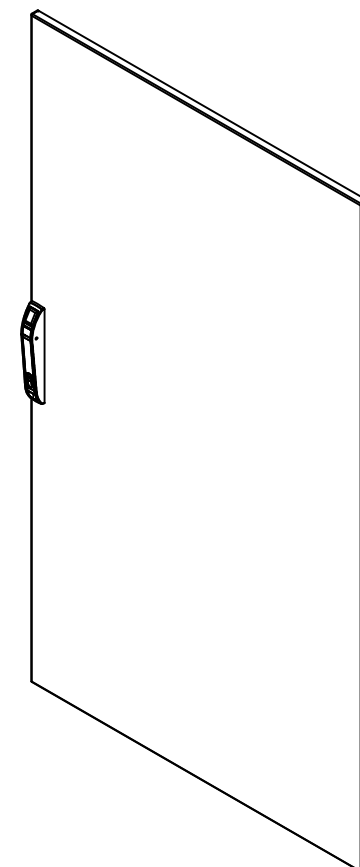

Isometric View

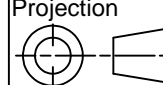

No.	Revisions	Date	By/Par

 Tél: (450) 979-4373 Fax: (450) 979-4626 <a href="http://www.exmweb.com">www.exmweb.com</a>		Flatness Aplatissement Max 3.0mm Projection 
Customer Client	Date	
Drawn By Dessiné Par	BoxCad: Annie	Date 05/02/2015
Material Matière	14 Ga H.R.P. & O. (1.7mm)	
Color Couleur	Light Grey RAL7035	Finish Fini
Description		Detail Rev.
6500 MXD 1600mm x 900mm Front		
Part Number Numéro Pièce	Rev.	1
<b>6500MXK160905F</b>	<b>0</b>	3

SEE BILL OF MATERIAL ON LAST PAGE

This drawing is confidential and must not be reproduced or used without the consent of EXM

Ce dessin est confidentiel et ne doit pas être reproduit ou utilisé sans le consentement de EXM

**STANDARD FEATURES ARE NOT LISTED IN THIS HOLE TABLE**

**HOLE TABLE - FRONT VIEW (CUSTOM FEATURE ONLY)**

CUT-OUT	XDIM	YDIM	DESCRIPTION
1	100.0	130.0	GND STUD M6 x 16mm (Inside)
2	100.0	1430.0	GND STUD M6 x 16mm (Inside)
3	64.5	49.5	STIFF. STUD M6 x 18mm (Inside)
4	64.5	780.0	STIFF. STUD M6 x 18mm (Inside)
5	64.5	1510.5	STIFF. STUD M6 x 18mm (Inside)
6	830.5	49.5	STIFF. STUD M6 x 18mm (Inside)
7	830.5	780.0	STIFF. STUD M6 x 18mm (Inside)
8	830.5	1510.5	STIFF. STUD M6 x 18mm (Inside)
9	869.5	155.0	CLOSING BAR GUIDE (Inside)
10	869.5	1405.0	CLOSING BAR GUIDE (Inside)
11	869.5	605.0	CLOSING BAR GUIDE (Inside)
12	869.5	955.0	CLOSING BAR GUIDE (Inside)

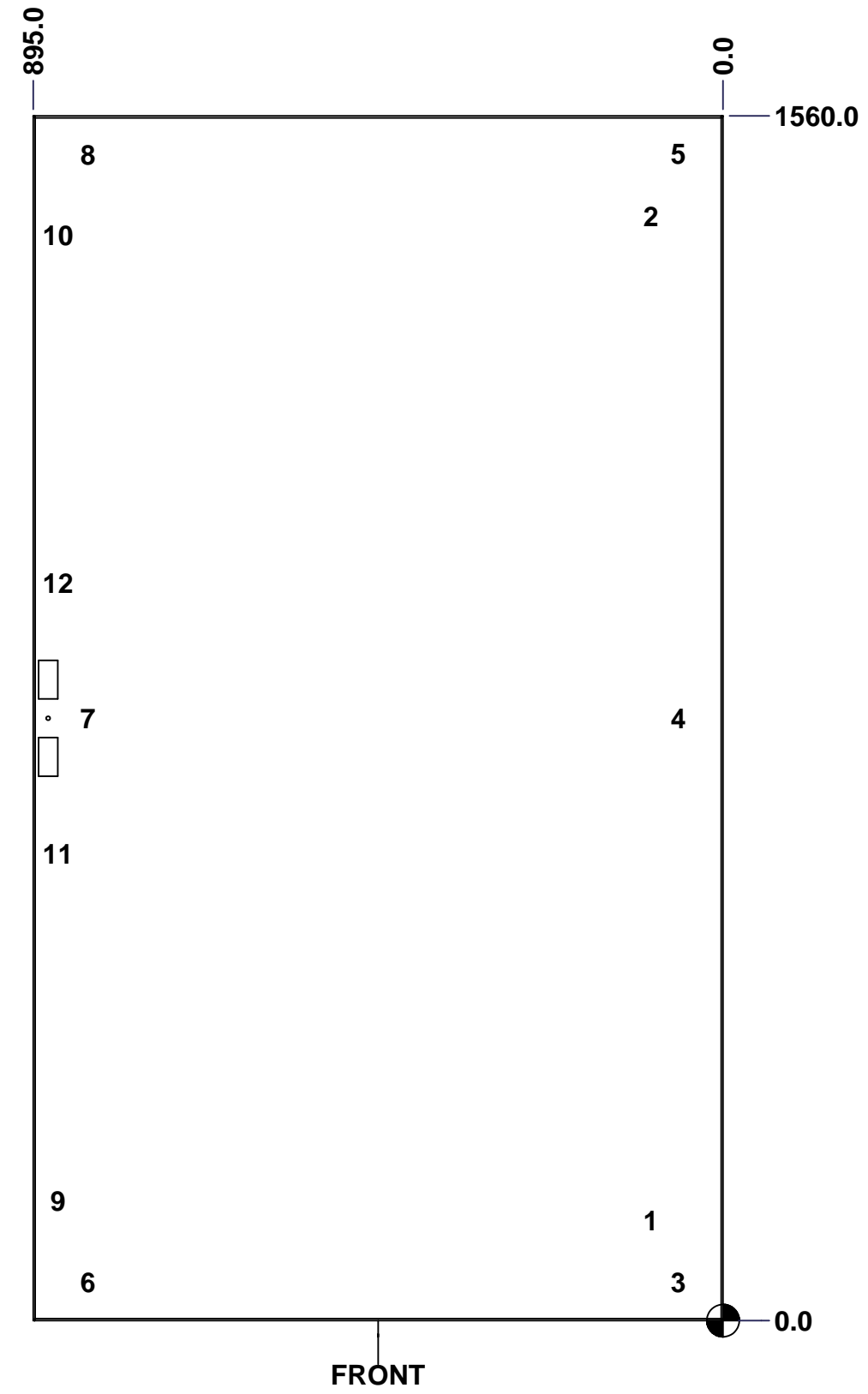

	Description 6500 MXD 1600mm x 900mm Front		Status (NULL)	
	Part Number Numéro Pièce <b>6500MXK160905F</b>		Rev. <b>0</b>	2 3

This drawing is confidential and must not be reproduced or used without the consent of EXM

Ce dessin est confidentiel et ne doit pas être reproduit ou utilisé sans le consentement de EXM

No.	Revisions	Date	By/Par

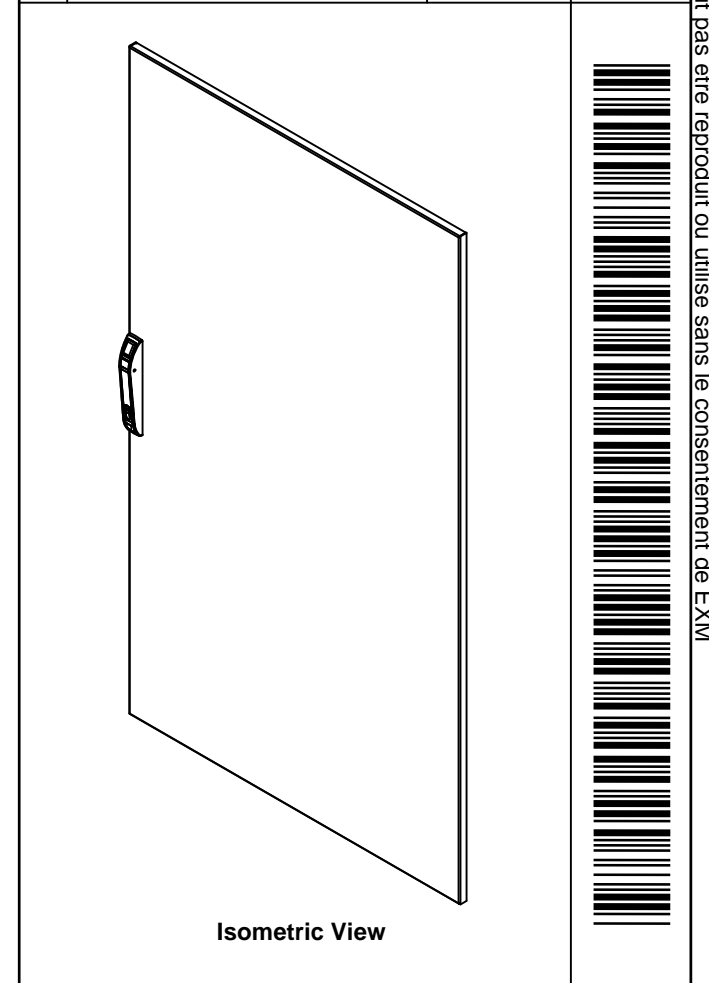

1	STK-P-03820R	0	Powder Paint (Light Grey / Rough Textured)
1	6500MXSRK	1	6500 MXRSK Door Support Roller
4	STK-Q-78022	0	Mtrx Closing Bar Slider
1	STK-Q-45746-16	1	6500 MXD - Lock Door Closing Bar
4	STK-Q-33105	4	5412 ESBU Buttable Hinge (Cover Part)
1	STK-Q-45729-16	2	6500 MXD - Lock Door Top Closing Bar
1	886PHD-S	4	Euroform Pull Handle Kit
8	STK-Q-16055	1	M6 x 18mm Stud (No Paint Cap Required)
1	6500MXK160905DS1	5	6500 MX 1600mm x 900mm Door Stiffener
1	6500MXK160905FG	0	6500 MXD 1600mm x 900mm Front Gasket
1	6500MXK160905F-P	0	6500 MXD 1600mm x 900mm Front Part
4	STK-K-06811	1	6500 MX - Hinge Assy
Qty	Part Number	Rev	Description
Parts List			

<p>Tél: (450) 979-4373 Fax: (450) 979-4626 <a href="http://www.exmweb.com">www.exmweb.com</a></p>	Flatness Aplatissement	Max 3.0mm
	Projection	
Customer Client	Date	
Drawn By Dessiné Par	BoxCad: Annie	Date 05/02/2015
Material Matière	14 Ga H.R.P. & O. (1.7mm)	
Color Couleur	Light Grey RAL7035	Finish Fini
		Rough Textured
Description	Detail Rev.	
6500 MXD 1600mm x 900mm Front		
Part Number Numéro Pièce	Rev.	3
<b>6500MXK160905F</b>	<b>0</b>	<b>3</b>



This drawing is confidential and must not be reproduced or used without the consent of EXM

Ce dessin est confidentiel et ne doit pas être reproduit ou utilisé sans le consentement de EXM

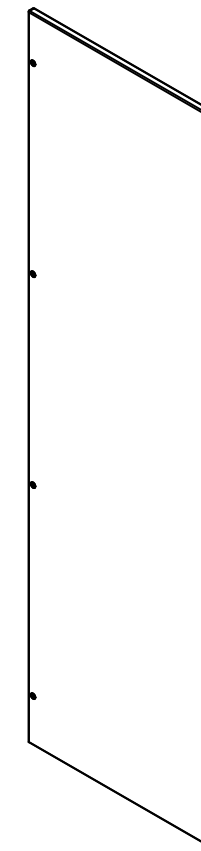
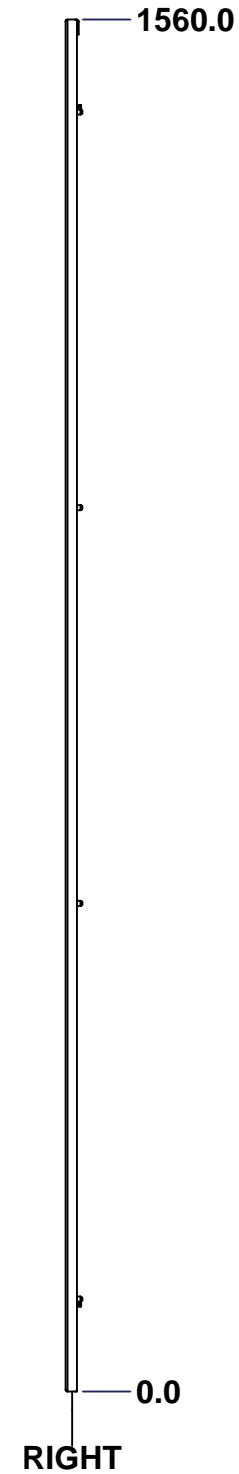
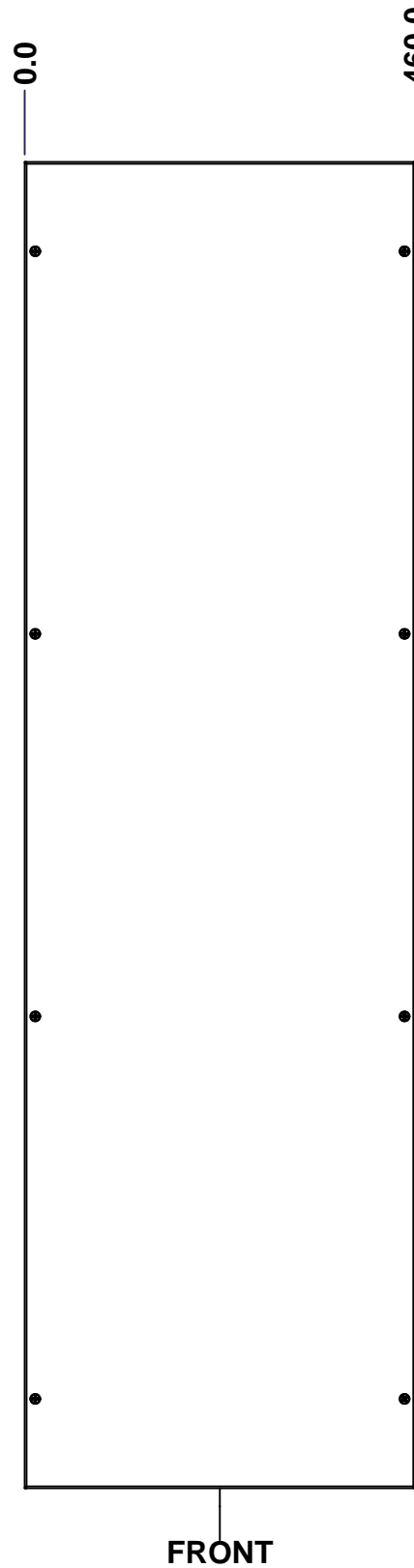
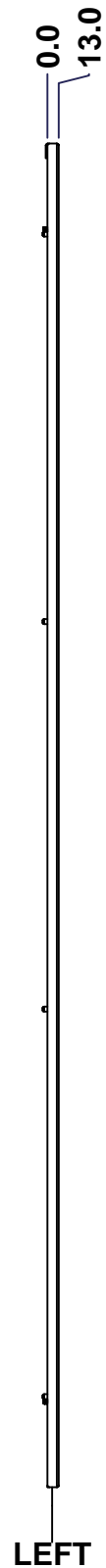
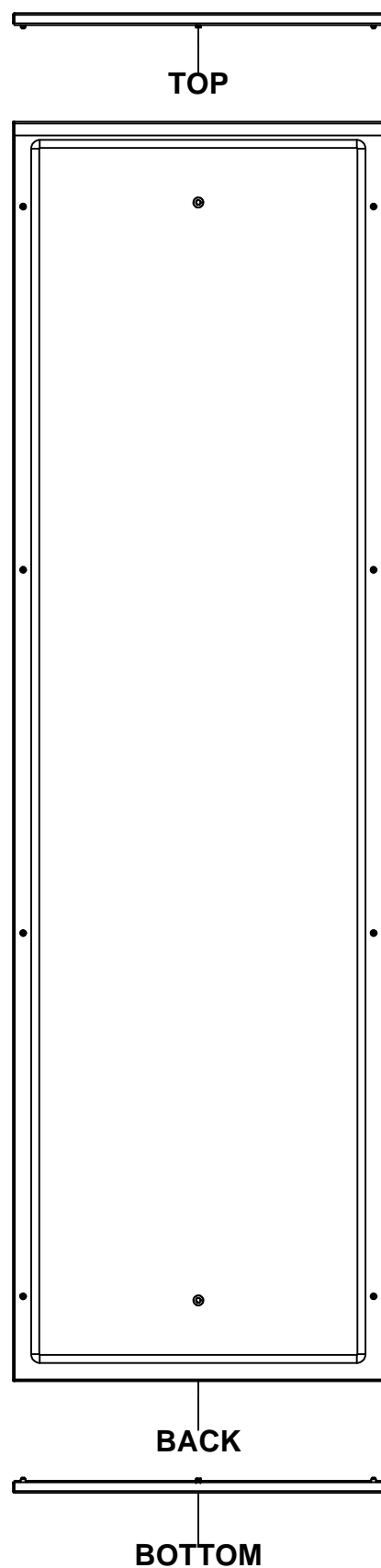

Isometric View

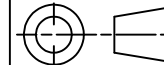

No.	Revisions	Date	By/Par

 Tél: (450) 979-4373 Fax: (450) 979-4626 <a href="http://www.exmweb.com">www.exmweb.com</a>		Flatness Aplatissement Max 3.0mm Projection 
Customer Client	Date	
Drawn By Dessiné Par	BoxCad: Annie	Date 05/02/2015
Material Matière	16 Ga H.R.P. & O. (1.4mm)	
Color Couleur	Light Grey RAL7035	Finish Fini
Description		Detail Rev.
6500 MXC 1600mm x 500mm Left		
Part Number Numéro Pièce	Rev.	
<b>6500MXK160905L</b>	<b>0</b>	1 / 3

SEE BILL OF MATERIAL ON LAST PAGE

This drawing is confidential and must not be reproduced or used without the consent of EXM

Ce dessin est confidentiel et ne doit pas être reproduit ou utilisé sans le consentement de EXM

STANDARD FEATURES ARE NOT LISTED IN THIS HOLE TABLE			
HOLE TABLE - FRONT VIEW (CUSTOM FEATURE ONLY)			
CUT-OUT	XDIM	YDIM	DESCRIPTION
1	230.0	100.0	GND STUD M6 x 16mm (Inside)
2	230.0	1460.0	GND STUD M6 x 16mm (Inside)

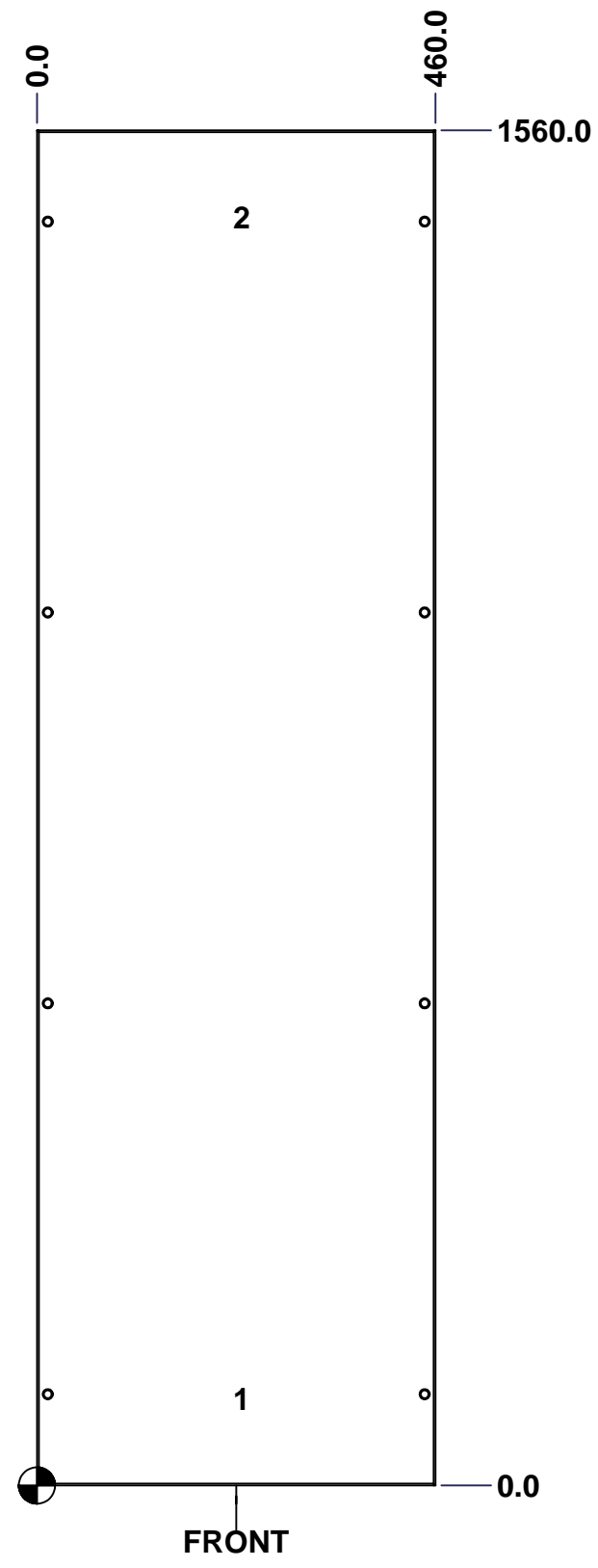

	Description	Status
	6500 MXC 1600mm x 500mm Left	(NULL)
	Part Number Numéro Pièce	Rev.
	<b>6500MXK160905L</b>	<b>0</b>
		2
		3

This drawing is confidential and must not be reproduced or used without the consent of EXM

Ce dessin est confidentiel et ne doit pas être reproduit ou utilisé sans le consentement de EXM

No.	Revisions	Date	By/Par

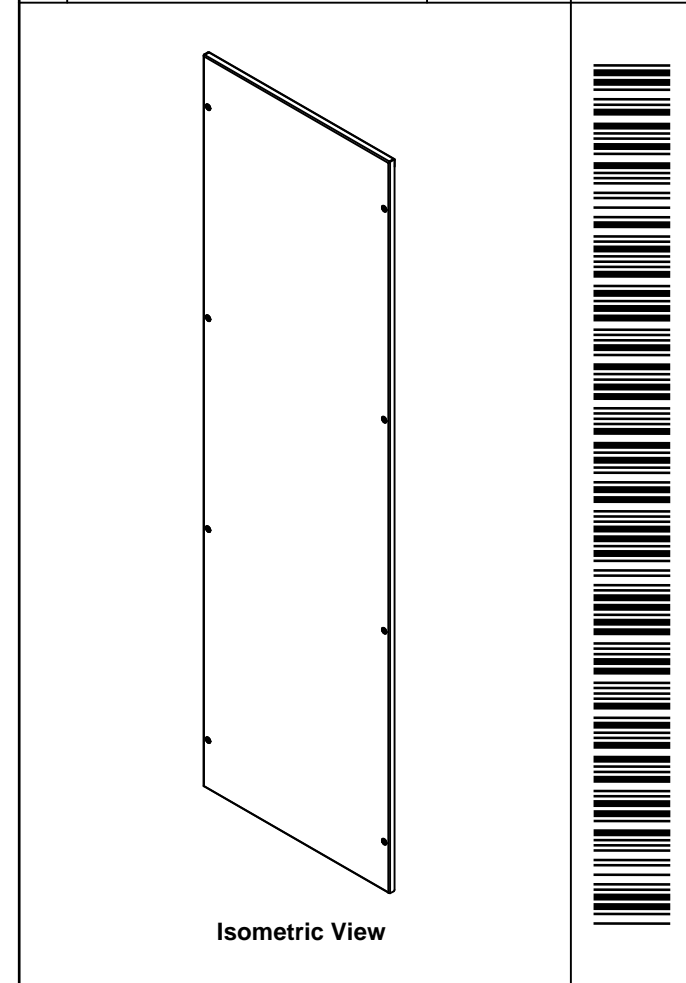

Tél: (450) 979-4373 Fax: (450) 979-4626 <a href="http://www.exmweb.com">www.exmweb.com</a>		Flatness Aplatissement	
		Max 3.0mm Projection	
Customer Client		Date	
Drawn By Dessiné Par BoxCad: Annie		Date 05/02/2015	
Material Matière 16 Ga H.R.P. & O. (1.4mm)			
Color Couleur Light Grey RAL7035		Finish Fini Rough Textured	
Description 6500 MXC 1600mm x 500mm Left			Detail Rev.
Part Number Numéro Pièce <b>6500MXK160905L</b>			Rev. 3

Qty	Part Number	Rev	Description
1	STK-P-03820R	0	Powder Paint (Light Grey / Rough Textured)
8	STK-Q-03072	2	M6 x 17mm Phillips Flat Head Screw
2	STK-Q-16080	0.1.1	M6 x 16mm Ground Stud
1	6500MXK160905LG	0	6500 MXC 1600mm x 500mm Left Gasket
1	6500MXK160905L-P	0	6500 MXC 1600mm x 500mm Left Part
Parts List			

This drawing is confidential and must not be reproduced or used without the consent of EXM

Ce dessin est confidentiel et ne doit pas être reproduit ou utilisé sans le consentement de EXM

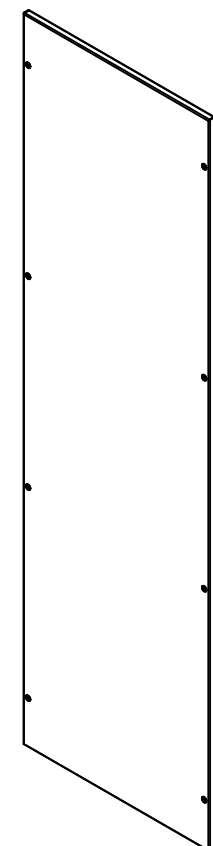
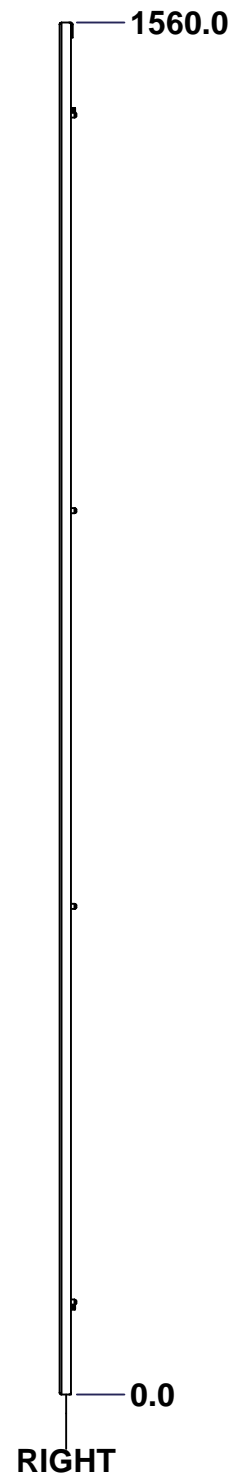
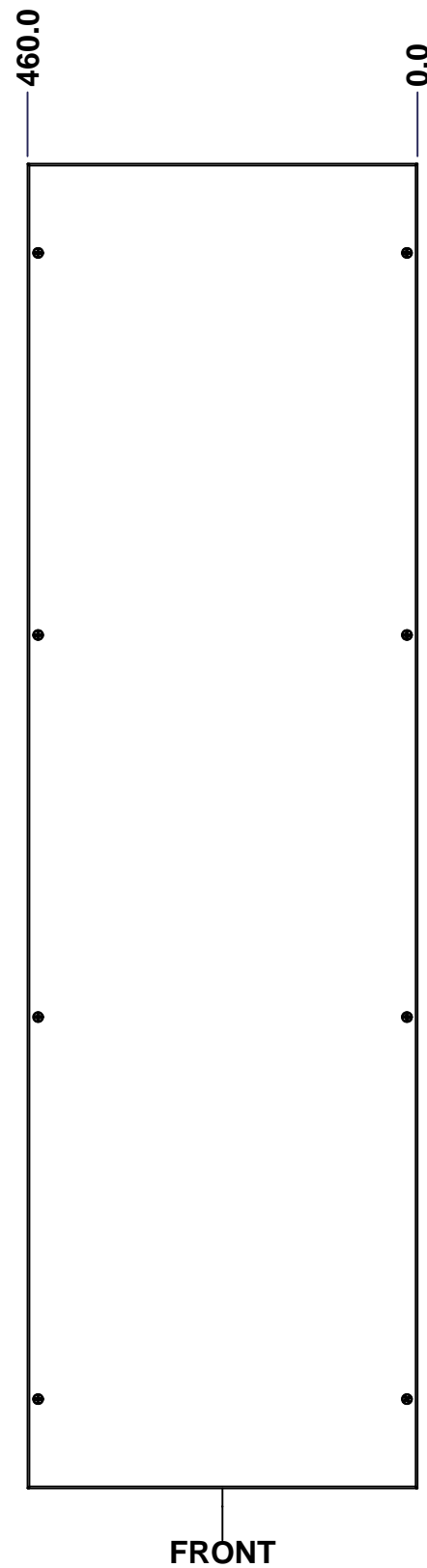
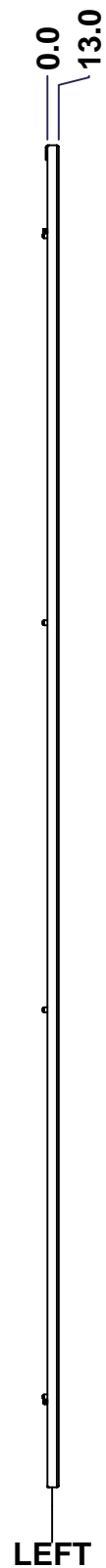
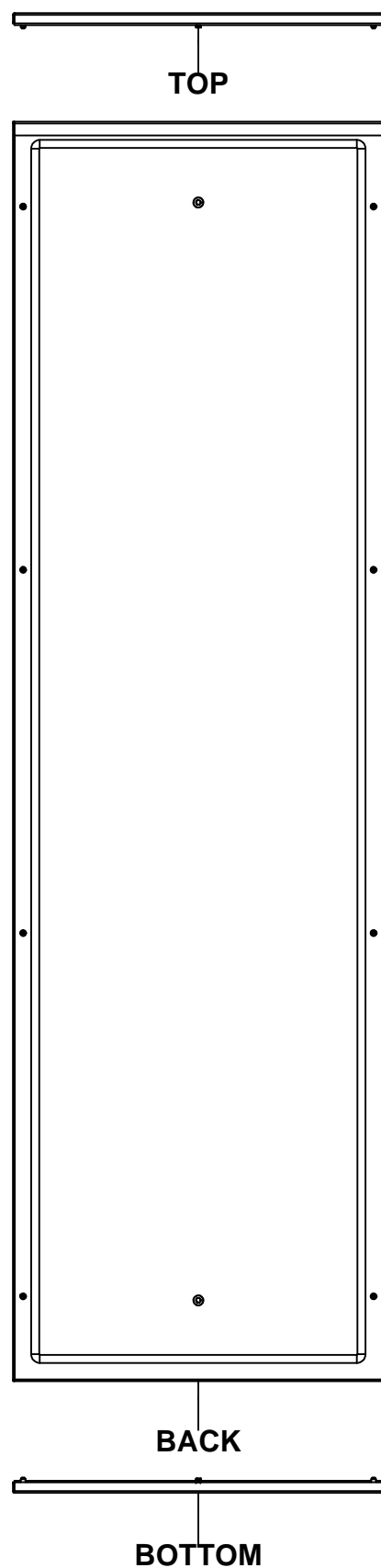

Isometric View

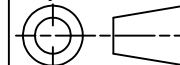

No.	Revisions	Date	By/Par

 Tél: (450) 979-4373 Fax: (450) 979-4626 <a href="http://www.exmweb.com">www.exmweb.com</a>		Flatness Aplatissement Max 3.0mm Projection 
Customer Client	Date	
Drawn By Dessiné Par	BoxCad: Annie	Date 05/02/2015
Material Matière	16 Ga H.R.P. & O. (1.4mm)	
Color Couleur	Light Grey RAL7035	Finish Fin Rough Textured
Description 6500 MXC 1600mm x 500mm Right		Detail Rev.
Part Number Numéro Pièce	6500MXK160905R	Rev. 1 0 3

SEE BILL OF MATERIAL ON LAST PAGE

This drawing is confidential and must not be reproduced or used without the consent of EXM

Ce dessin est confidentiel et ne doit pas être reproduit ou utilisé sans le consentement de EXM

STANDARD FEATURES ARE NOT LISTED IN THIS HOLE TABLE			
HOLE TABLE - FRONT VIEW (CUSTOM FEATURE ONLY)			
CUT-OUT	XDIM	YDIM	DESCRIPTION
1	230.0	100.0	GND STUD M6 x 16mm (Inside)
2	230.0	1460.0	GND STUD M6 x 16mm (Inside)

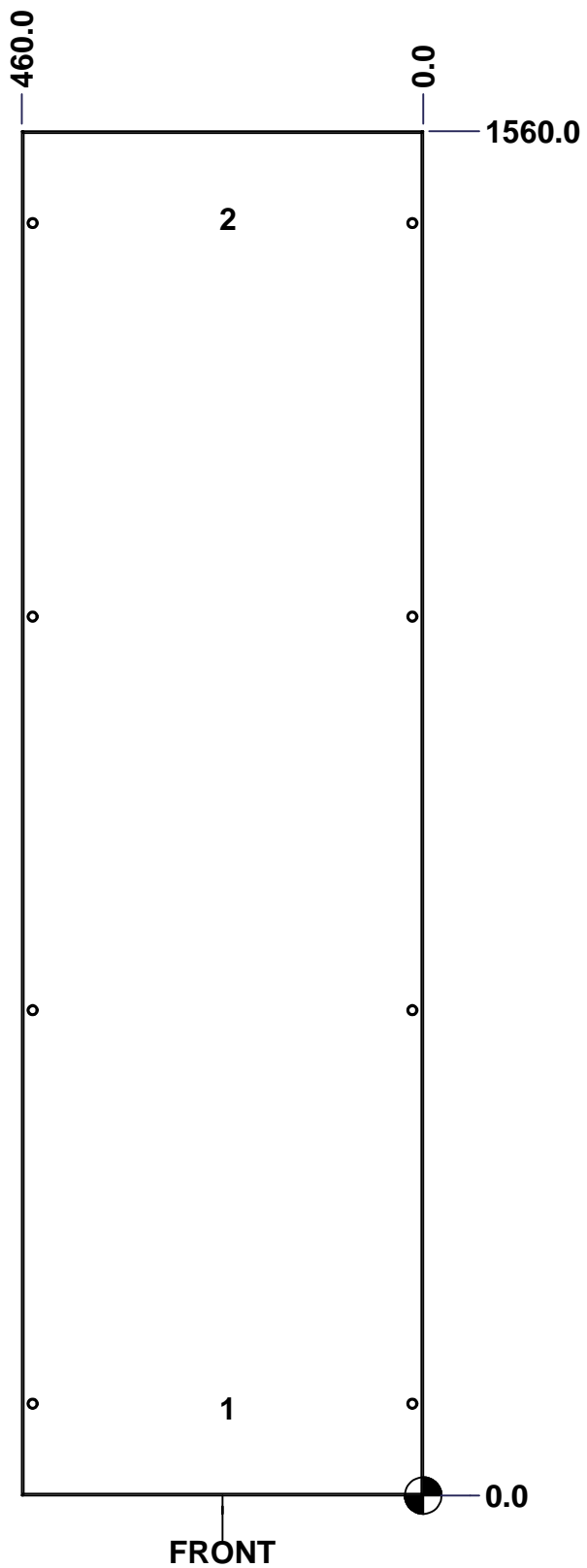

	Description	Status
	6500 MXC 1600mm x 500mm Right	(NULL)
	Part Number Numéro Pièce	Rev.
	<b>6500MXK160905R</b>	<b>0</b>
		2
		3

This drawing is confidential and must not be reproduced or used without the consent of EXM

Ce dessin est confidentiel et ne doit pas être reproduit ou utilisé sans le consentement de EXM

No.	Revisions	Date	By/Par

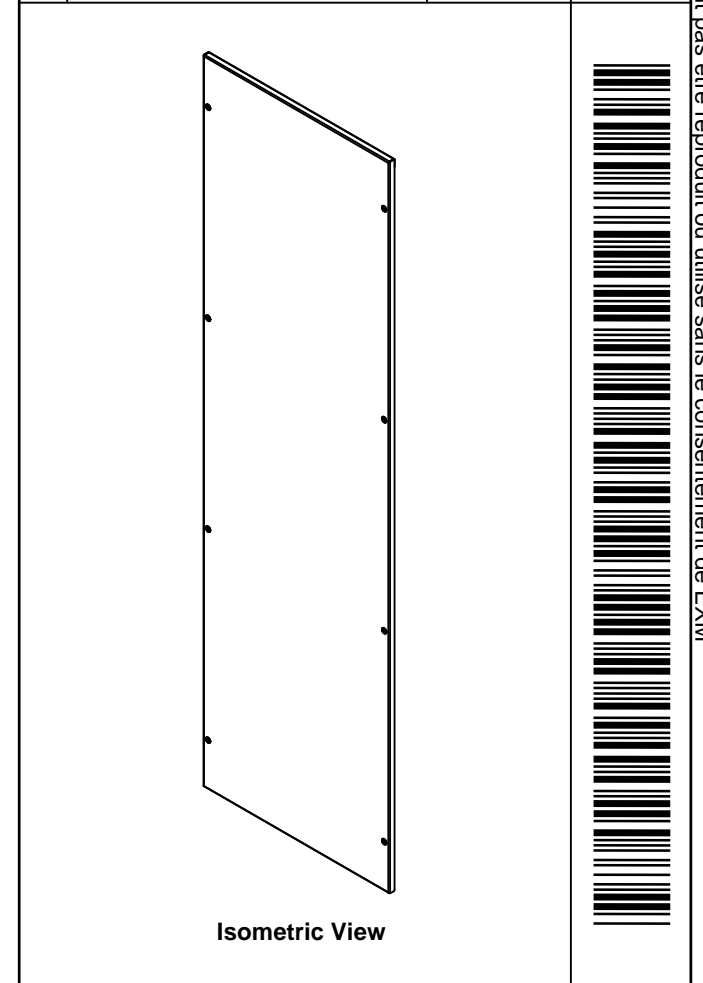

Tél: (450) 979-4373 Fax: (450) 979-4626 <a href="http://www.exmweb.com">www.exmweb.com</a>		Flatness Aplatissement	
		Max 3.0mm Projection	
Customer Client		Date	
Drawn By Dessiné Par BoxCad: Annie		Date 05/02/2015	
Material Matière 16 Ga H.R.P. & O. (1.4mm)			
Color Couleur Light Grey RAL7035		Finish Fini Rough Textured	
Description 6500 MXC 1600mm x 500mm Right			Detail Rev.
Part Number Numéro Pièce <b>6500MXK160905R</b>		Rev. <b>0</b>	3 3

Qty	Part Number	Rev	Description
1	STK-P-03820R	0	Powder Paint (Light Grey / Rough Textured)
8	STK-Q-03072	2	M6 x 17mm Phillips Flat Head Screw
2	STK-Q-16080	0.1.1	M6 x 16mm Ground Stud
1	6500MXK160905RG	0	6500 MXC 1600mm x 500mm Right Gasket
1	6500MXK160905R-P	0	6500 MXC 1600mm x 500mm Right Part
Parts List			

This drawing is confidential and must not be reproduced or used without the consent of EXM

Ce dessin est confidentiel et ne doit pas être reproduit ou utilisé sans le consentement de EXM

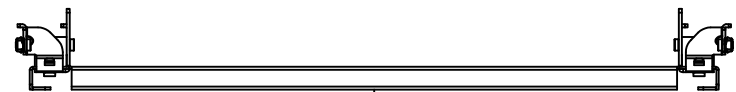

TOP

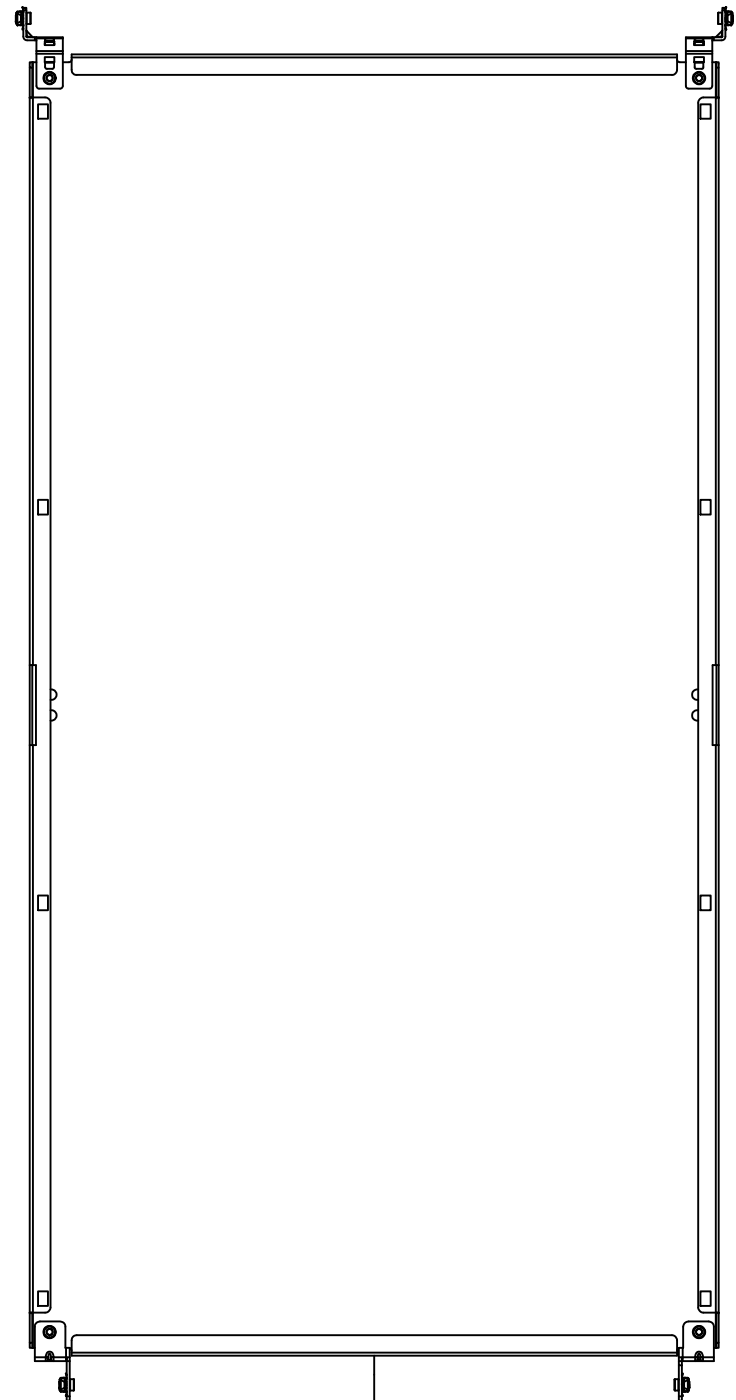

BACK



BOTTOM

0.0  
26.0

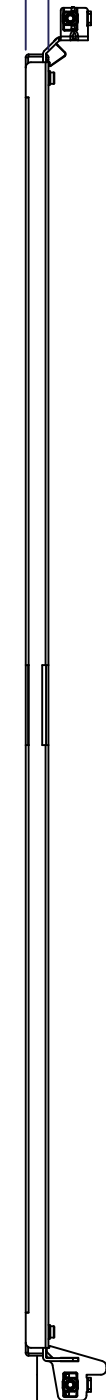

LEFT

0.0  
785.0

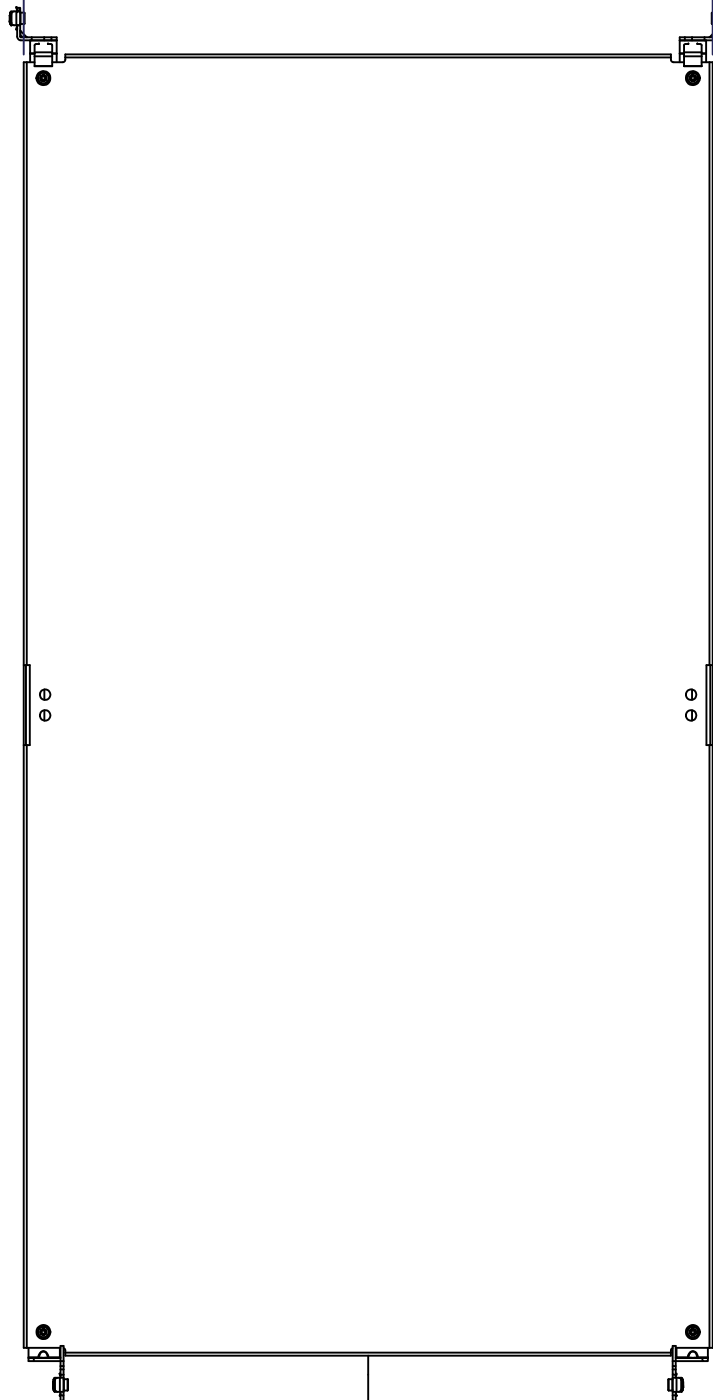

FRONT

1480.0

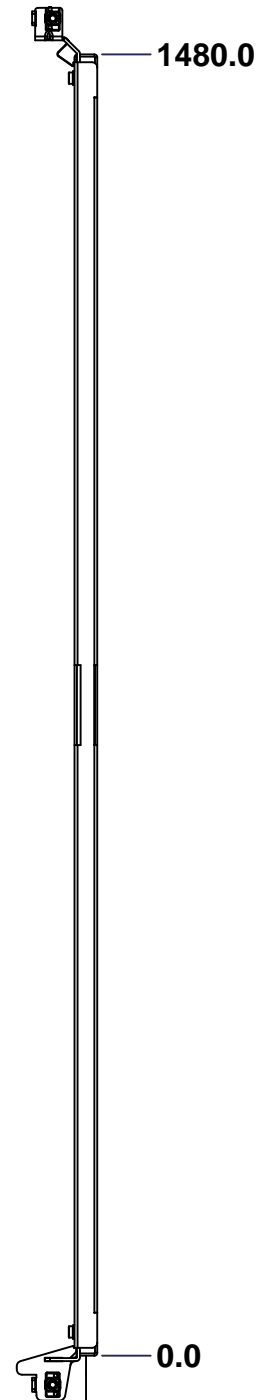

RIGHT

0.0

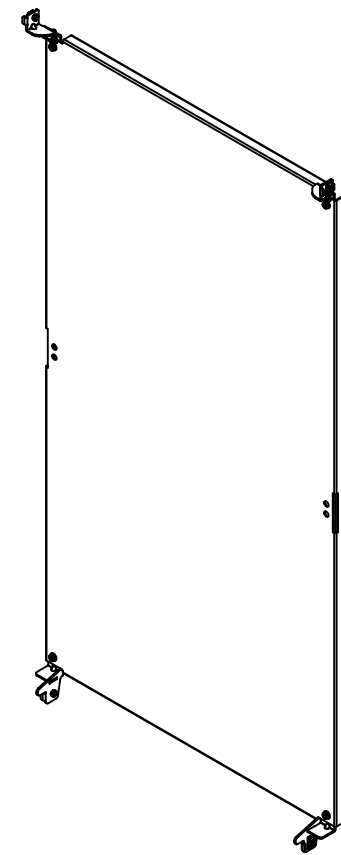

Isometric View



Tél: (450) 979-4373  
Fax: (450) 979-4626  
[www.exmweb.com](http://www.exmweb.com)

Flatness  
Aplatissement

Max 3.0mm

Projection

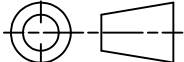

Customer Client	Date
Drawn By Dessiné Par	Date
BoxCad: Annie	05/02/2015

Material Matière: 12 Ga Galvanized (2.5mm)

Color Couleur	Unpainted	Finish Fini	Unpainted
---------------	-----------	-------------	-----------

Description: 6500 MXM 1600mm x 900mm Back Inner Panel  
Detail Rev.

Part Number Numéro Pièce	Rev.	1
<b>6500MXK160905BIP</b>	<b>0</b>	3

SEE BILL OF MATERIAL ON LAST PAGE

This drawing is confidential and must not be reproduced or used without the consent of EXM

Ce dessin est confidentiel et ne doit pas être reproduit ou utilisé sans le consentement de EXM

No.	Revisions	Date	By/Par

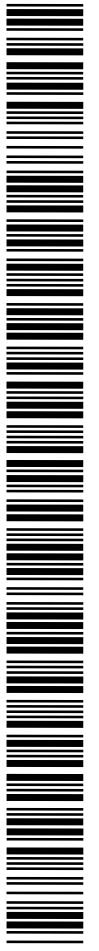
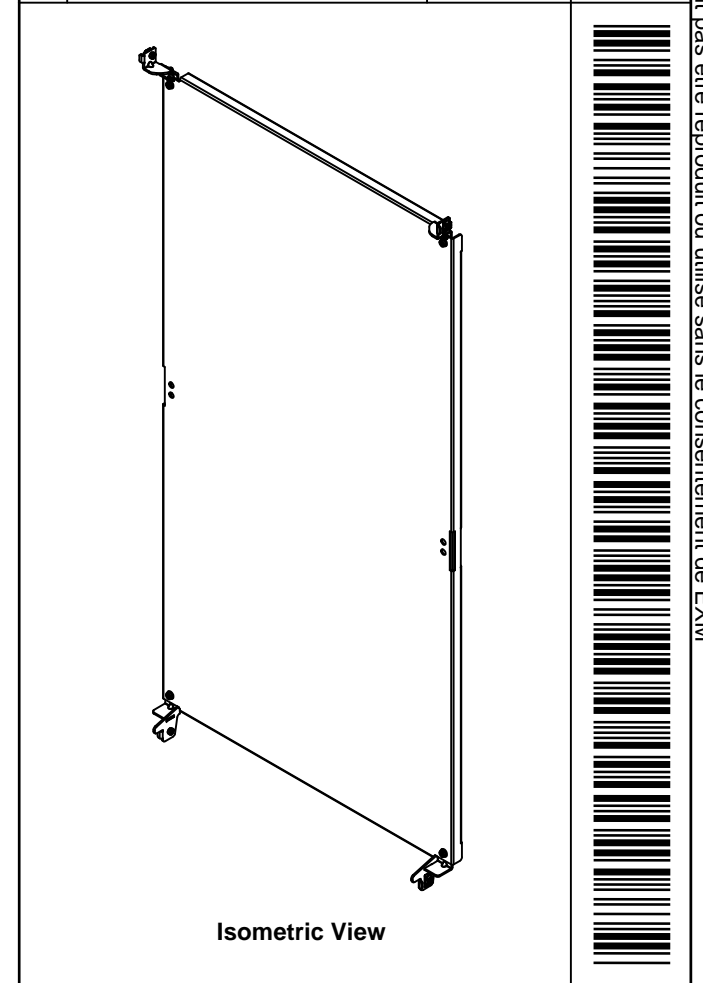

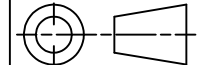
 Tél: (450) 979-4373 Fax: (450) 979-4626 <a href="http://www.exmweb.com">www.exmweb.com</a>		Flatness Aplatissement Max 3.0mm Projection 
Customer Client	Date	
Drawn By Dessiné Par	BoxCad: Annie	Date 05/02/2015
Material Matière	12 Ga Galvanized (2.5mm)	
Color Couleur	Unpainted	Finish Fini Unpainted
Description 6500 MXM 1600mm x 900mm Back Inner Panel		Detail Rev.
Part Number Numéro Pièce	<b>6500MXK160905BIP</b>	Rev. 3
		<b>0</b>

Qty	Part Number	Rev	Description
1	STK-A-49005	0	6500MXM - Bottom Inner Panel Support Kit (Right)
1	STK-A-49000	0	6500MXM - Bottom Inner Panel Support Kit (Left)
1	STK-A-49015	0	6500MXM - Top Inner Panel Support Kit (Right)
1	STK-A-49010	0	6500MXM - Top Inner Panel Support Kit (Left)
1	6500MXK160905BIP-P	0	6500 MXM 1600mm x 900mm Back Inner Panel Part
Parts List			