

This drawing is confidential and must not be reproduced or used without the consent of EXM

Ce dessin est confidentiel et ne doit pas être reproduit ou utilisé sans le consentement de EXM

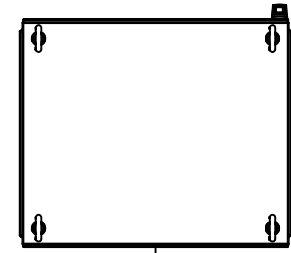

TOP

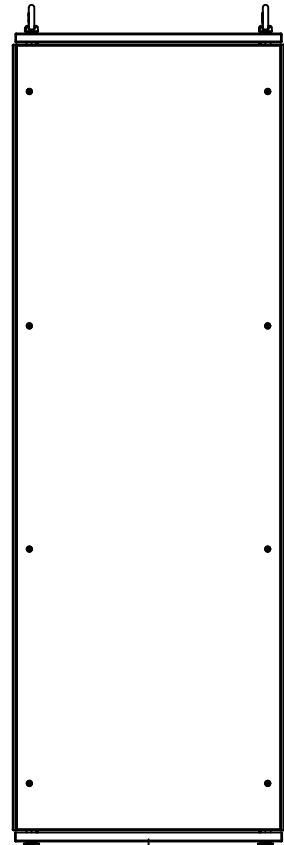

BACK

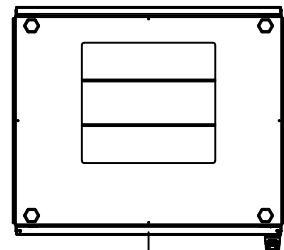

BOTTOM

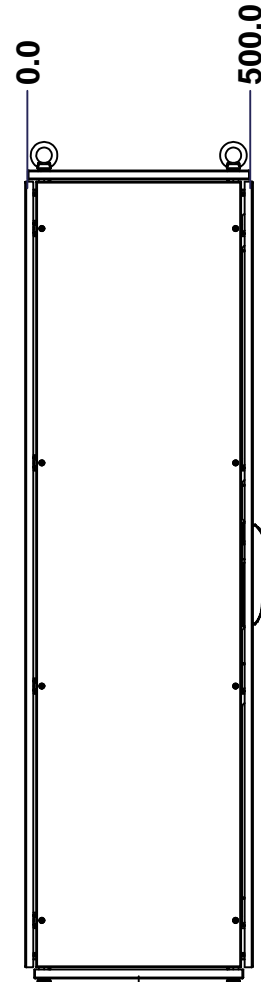

LEFT

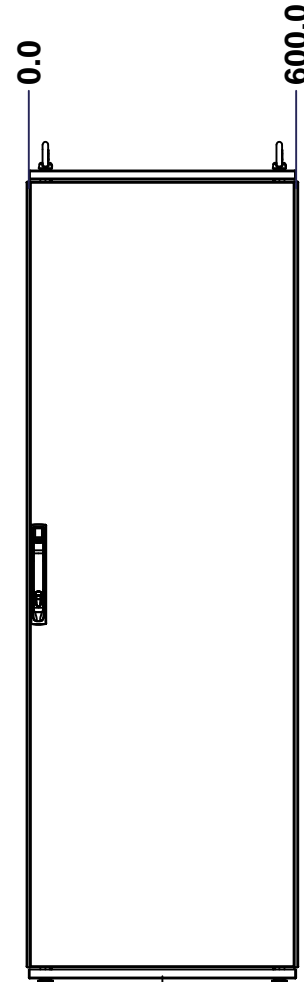

FRONT

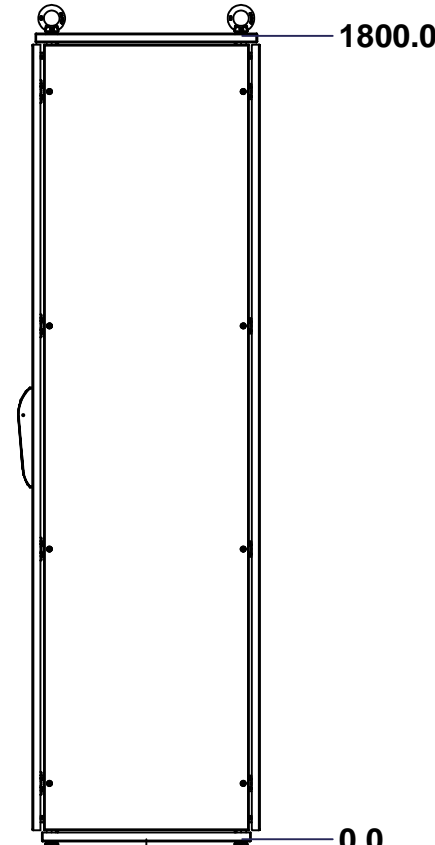

RIGHT

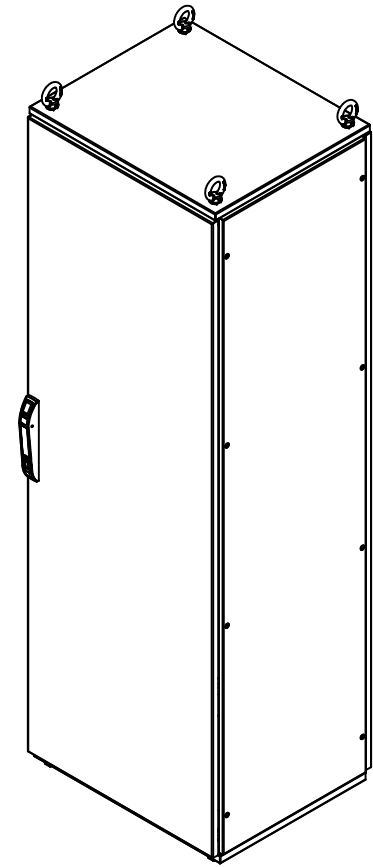

Isometric View

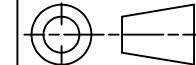

No.	Revisions	Date	By/Par

 Tél: (450) 979-4373 Fax: (450) 979-4626 www.exmweb.com		Flatness Aplatissement Max 3.0mm Projection 
Customer Client	Date	
Drawn By Dessiné Par	BoxCad: Annie	Date 10/02/2015
Material Matière	See Part List	
Color Couleur	See Part List	Finish Finis See Part List
Description 6500MX 1800mm x 600mm x 500mm Assembly	Detail Rev.	
Part Number Numéro Pièce	Rev. 0	1/2

SEE BILL OF MATERIAL ON LAST PAGE

6500MXK180605

This drawing is confidential and must not be reproduced or used without the consent of EXM

Ce dessin est confidentiel et ne doit pas être reproduit ou utilisé sans le consentement de EXM

No.	Revisions	Date	By/Par

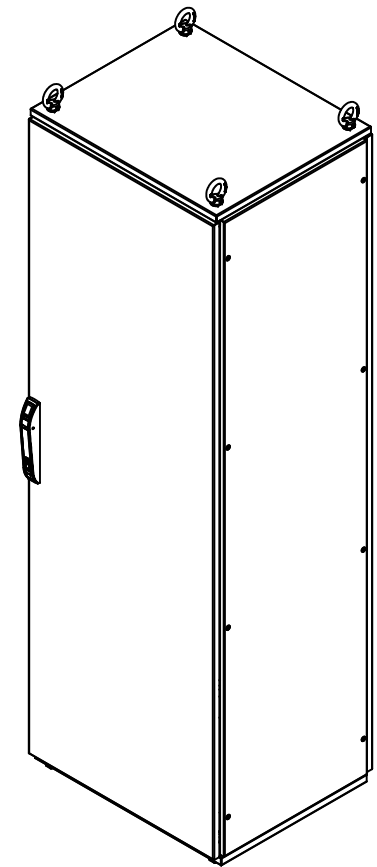

Isometric View



Tél: (450) 979-4373
 Fax: (450) 979-4626
www.exmweb.com

Flatness
Aplatissement
Max 3.0mm
Projection

Customer Client
 Drawn By Dessiné Par BoxCad: Annie
 Date 10/02/2015

Material Matière See Part List

Color Couleur See Part List
 Finish Fini See Part List

Description 6500MX 1800mm x 600mm x 500mm Assembly
 Detail Rev.

Part Number Numéro Pièce **6500MXK180605**
 Rev. 0

Qty	Part Number	Rev	Description
1	6500MXK180605BIP	0	6500 MXM 1800mm x 600mm Back Inner Panel
1	6500MXK180605R	0	6500 MXC 1800mm x 500mm Right
1	6500MXK180605L	0	6500 MXC 1800mm x 500mm Left
1	6500MXK180605F	0	6500 MXD 1800mm x 600mm Front
1	6500MXK180605B	0	6500 MXR 1800mm x 600mm Back
1	6500MXK180605BT	0	6500 MXB 600mm x 500mm Bottom
1	6500MXK180605T	0	6500 MXT 600mm x 500mm Top
1	6500MXK180605FR	0	6500 MX 1800mm x 600mm x 500mm Frame
Parts List			

2
2

This drawing is confidential and must not be reproduced or used without the consent of EXM

Ce dessin est confidentiel et ne doit pas être reproduit ou utilisé sans le consentement de EXM

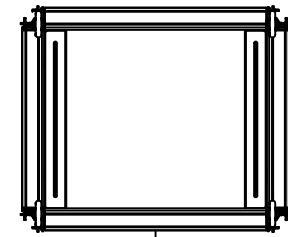

TOP

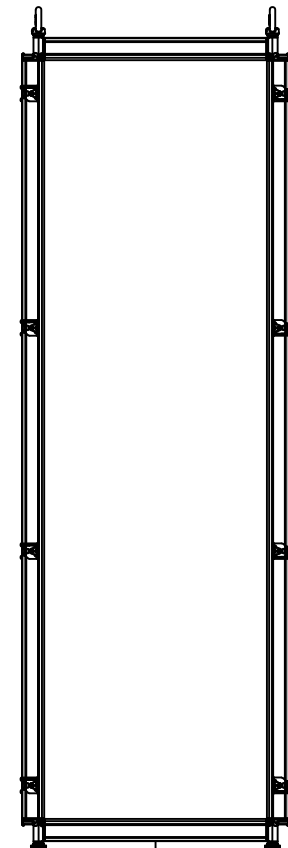

BACK

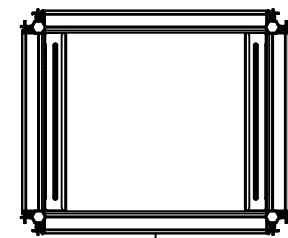

BOTTOM

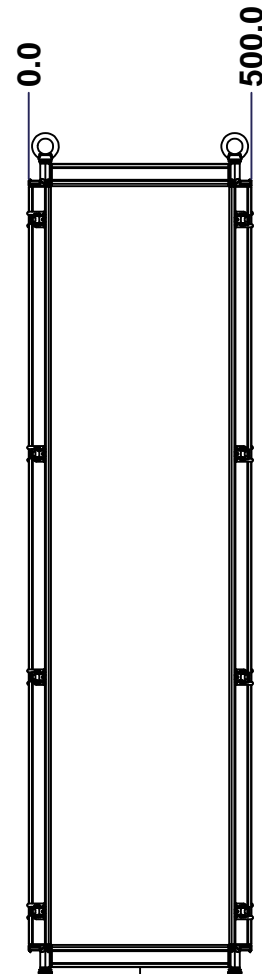

LEFT

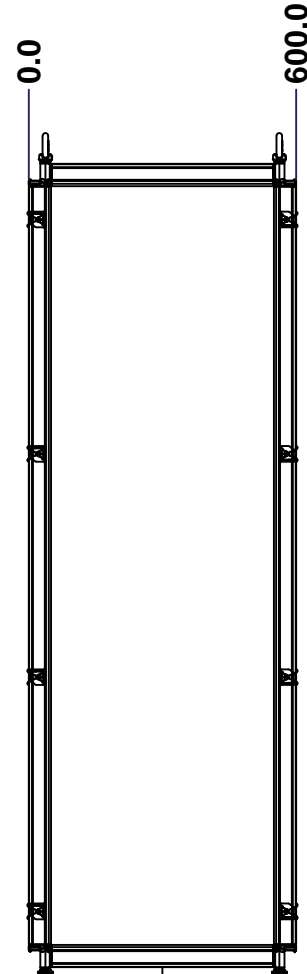

FRONT

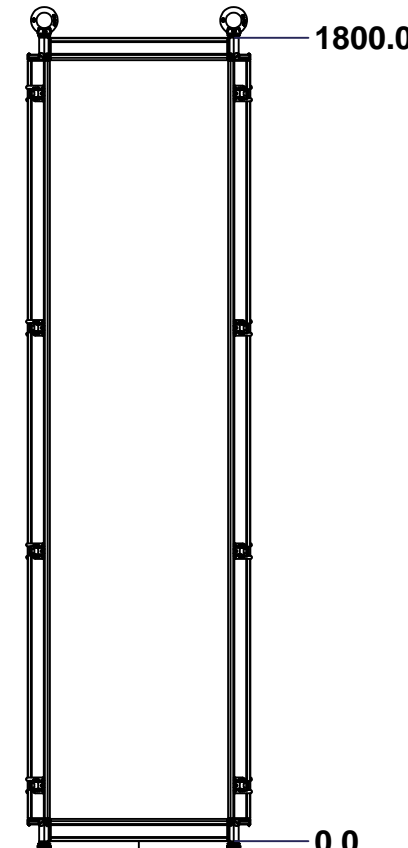

RIGHT

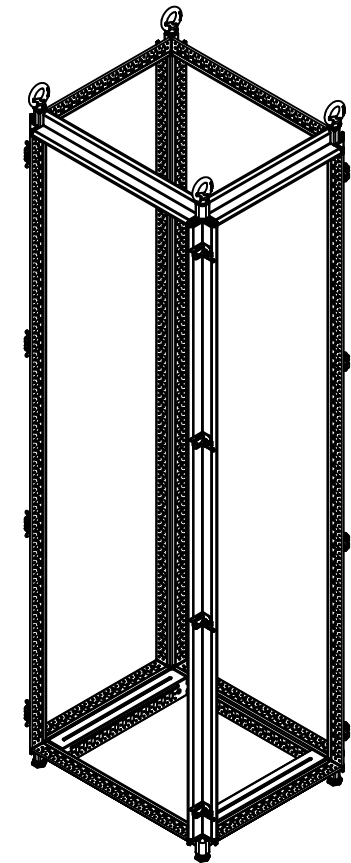

Isometric View

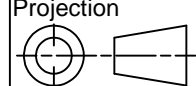

No.	Revisions	Date	By/Par

 Tél: (450) 979-4373 Fax: (450) 979-4626 www.exmweb.com		Flatness Aplatissement Max 3.0mm Projection 
Customer Client	Date	
Drawn By Dessiné Par	BoxCad: Annie	Date 10/02/2015
Material Matière	16 Ga Electro-Galvanized (1.4mm)	
Color Couleur	Iron Grey RAL7011	Finish Fin Rough Textured
Description	Detail Rev.	
6500 MX 1800mm x 600mm x 500mm Frame		
Part Number Numéro Pièce	Rev.	
6500MXK180605FR	0	1 2

SEE BILL OF MATERIAL ON LAST PAGE

This drawing is confidential and must not be reproduced or used without the consent of EXM

Ce dessin est confidentiel et ne doit pas être reproduit ou utilisé sans le consentement de EXM



TOP

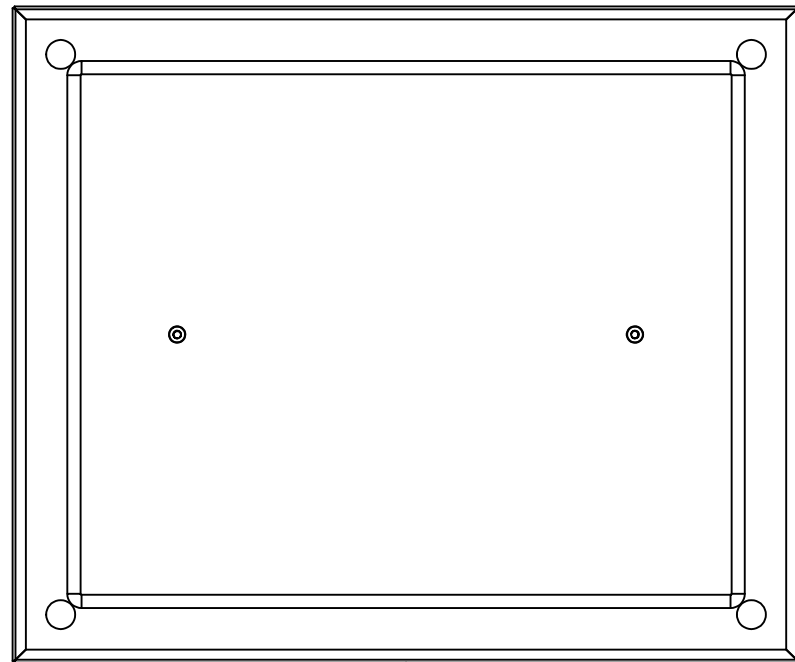

BACK

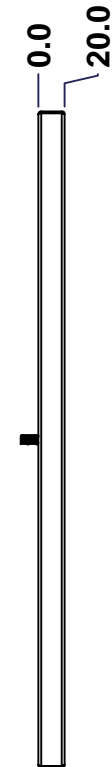

LEFT

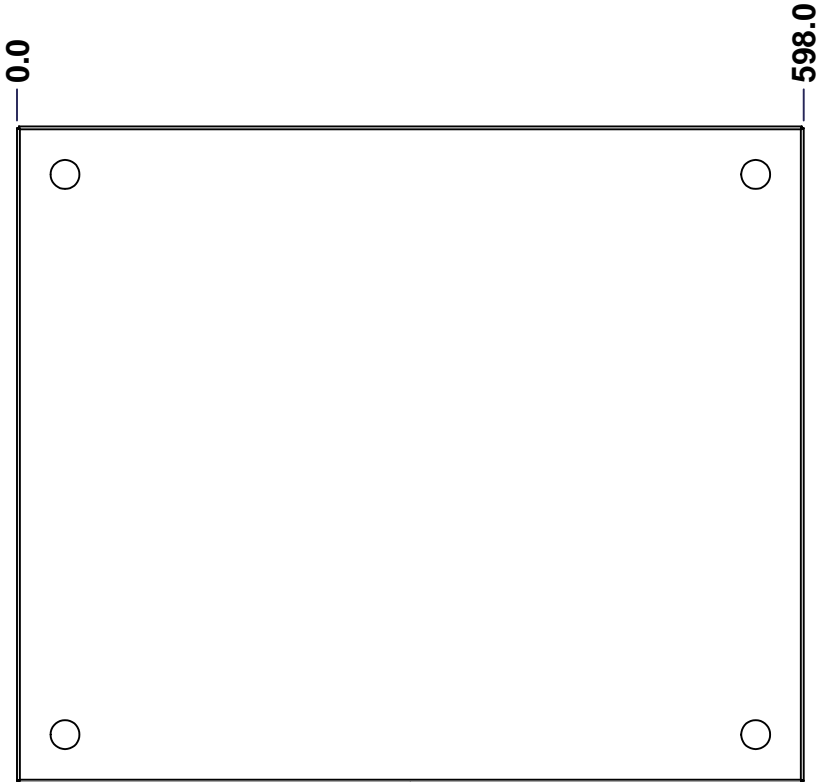

FRONT

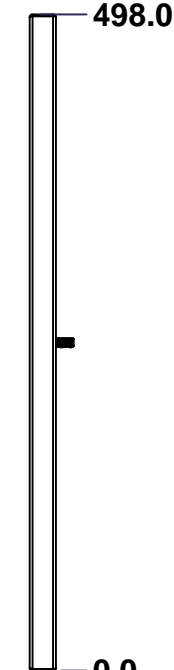

RIGHT

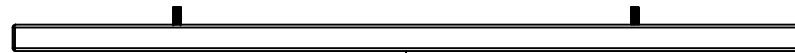

BOTTOM

No.	Revisions	Date	By/Par

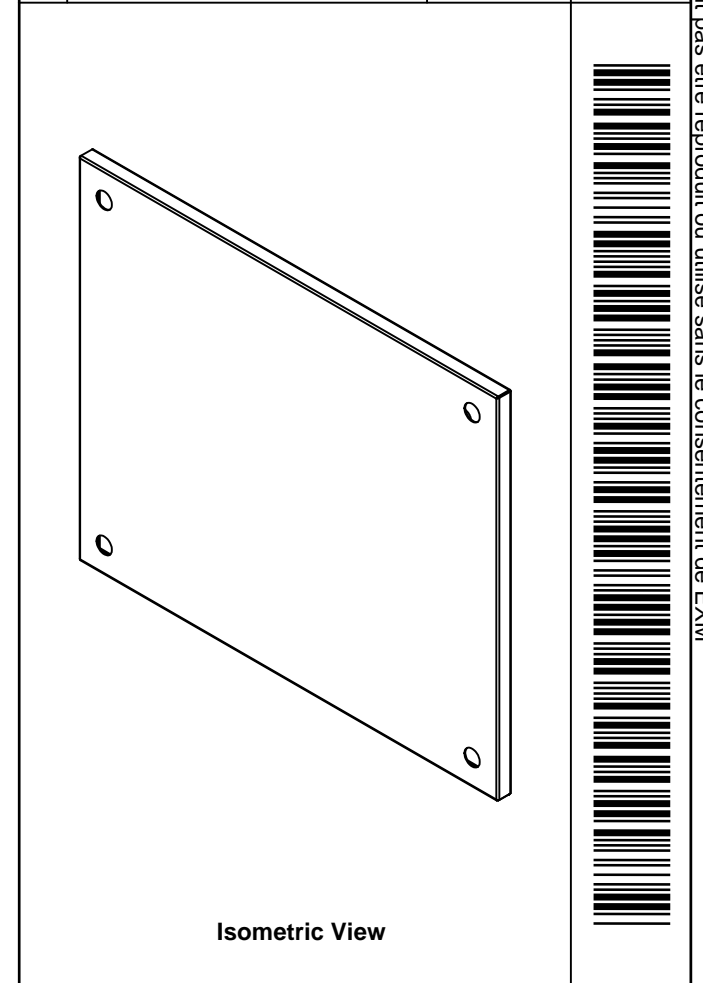

Isometric View



Tél: (450) 979-4373
 Fax: (450) 979-4626
www.exmweb.com

Flatness
 Aplatissement
 Max 3.0mm
 Projection

Customer Client	Date
Drawn By / Dessiné Par: BoxCad: Annie	Date: 10/02/2015
Material / Matière: 16 Ga H.R.P. & O. (1.4mm)	
Color / Couleur: Iron Grey RAL7011	Finish / Fini: Rough / Textured
Description: 6500 MXT 600mm x 500mm Top	
Part Number / Numéro Pièce: 6500MXK180605T	Detail Rev. / Rev. 1
SEE BILL OF MATERIAL ON LAST PAGE	Rev. 0

This drawing is confidential and must not be reproduced or used without the consent of EXM

Ce dessin est confidentiel et ne doit pas être reproduit ou utilisé sans le consentement de EXM

STANDARD FEATURES ARE NOT LISTED IN THIS HOLE TABLE			
HOLE TABLE - FRONT VIEW (CUSTOM FEATURE ONLY)			
CUT-OUT	XDIM	YDIM	DESCRIPTION
1	125.0	249.0	GND STUD M6 x 16mm (Inside)
2	473.0	249.0	GND STUD M6 x 16mm (Inside)



FRONT

	Description	Status
	6500 MXT 600mm x 500mm Top	(NULL)
	Part Number Numéro Pièce	Rev.
	6500MXK180605T	0
		2
		3

This drawing is confidential and must not be reproduced or used without the consent of EXM

Ce dessin est confidentiel et ne doit pas être reproduit ou utilisé sans le consentement de EXM

No.	Revisions	Date	By/Par

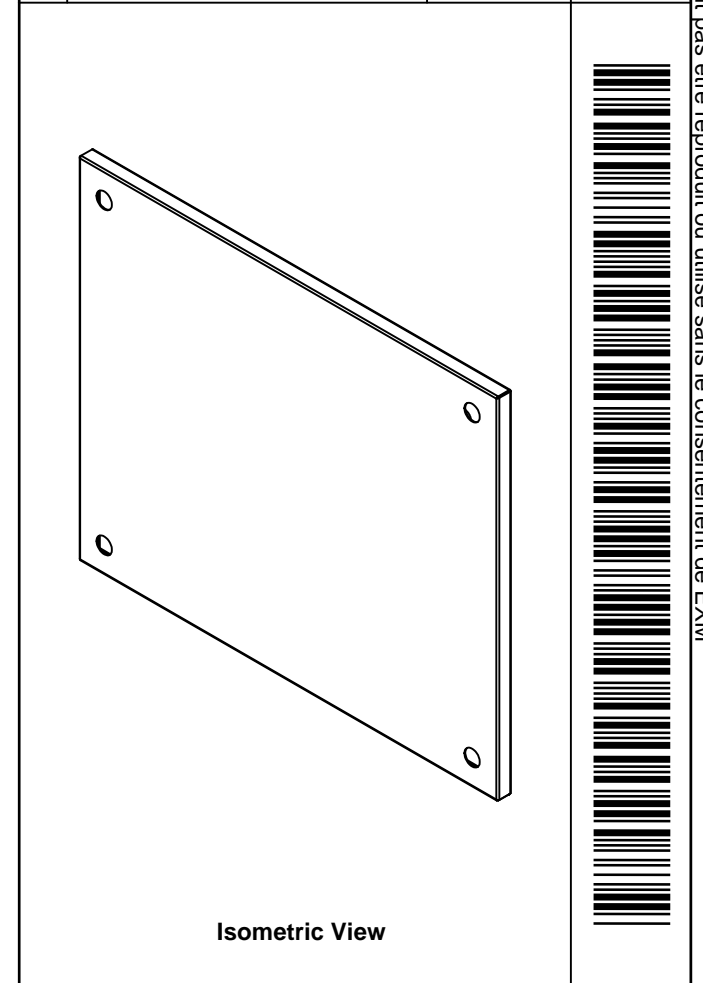

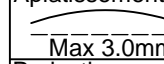
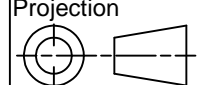
 Tél: (450) 979-4373 Fax: (450) 979-4626 www.exmweb.com		Flatness Aplatissement  Max 3.0mm Projection 
Customer Client	Date	
Drawn By Dessiné Par	BoxCad: Annie	Date 10/02/2015
Material Matière	16 Ga H.R.P. & O. (1.4mm)	
Color Couleur	Iron Grey RAL7011	Finish Fini Rough Textured
Description	Detail Rev.	
6500 MXT 600mm x 500mm Top		
Part Number Numéro Pièce	Rev.	3
6500MXK180605T	0	3

Qty	Part Number	Rev	Description
1	STK-P-03810R	0	Powder Paint (Iron Grey / Rough Textured)
2	STK-Q-16080	0.1.1	M6 x 16mm Ground Stud
1	6500MXK180605TG	0	6500 MXT 600mm x 500mm Top Gasket
1	6500MXK180605T-P	0	6500 MXT 600mm x 500mm Top Part
Parts List			

This drawing is confidential and must not be reproduced or used without the consent of EXM

Ce dessin est confidentiel et ne doit pas être reproduit ou utilisé sans le consentement de EXM



TOP

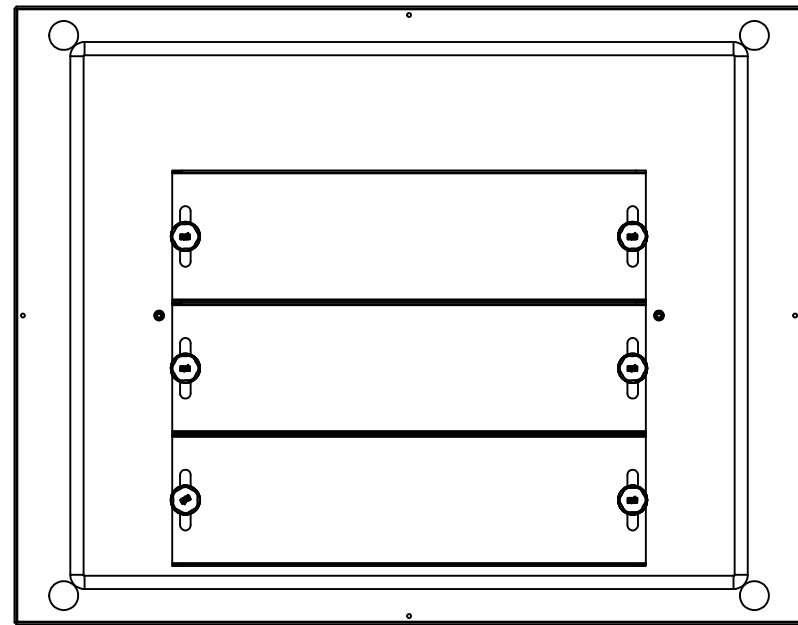

BACK

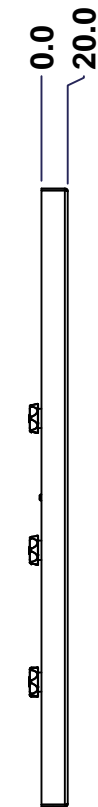

LEFT

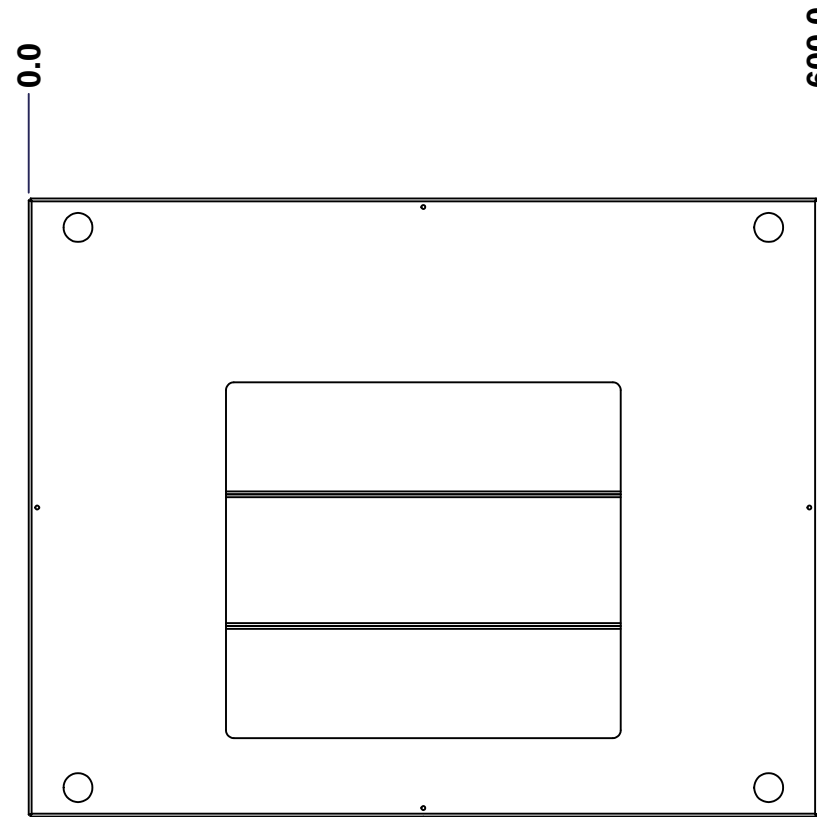

FRONT

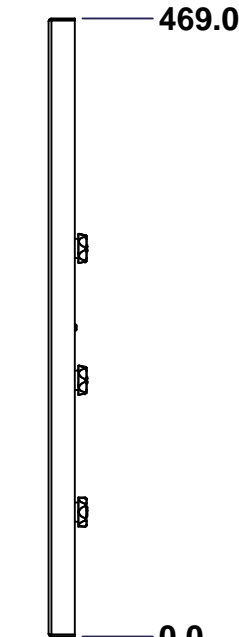

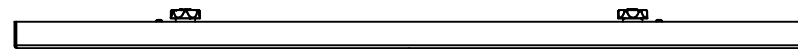

RIGHT

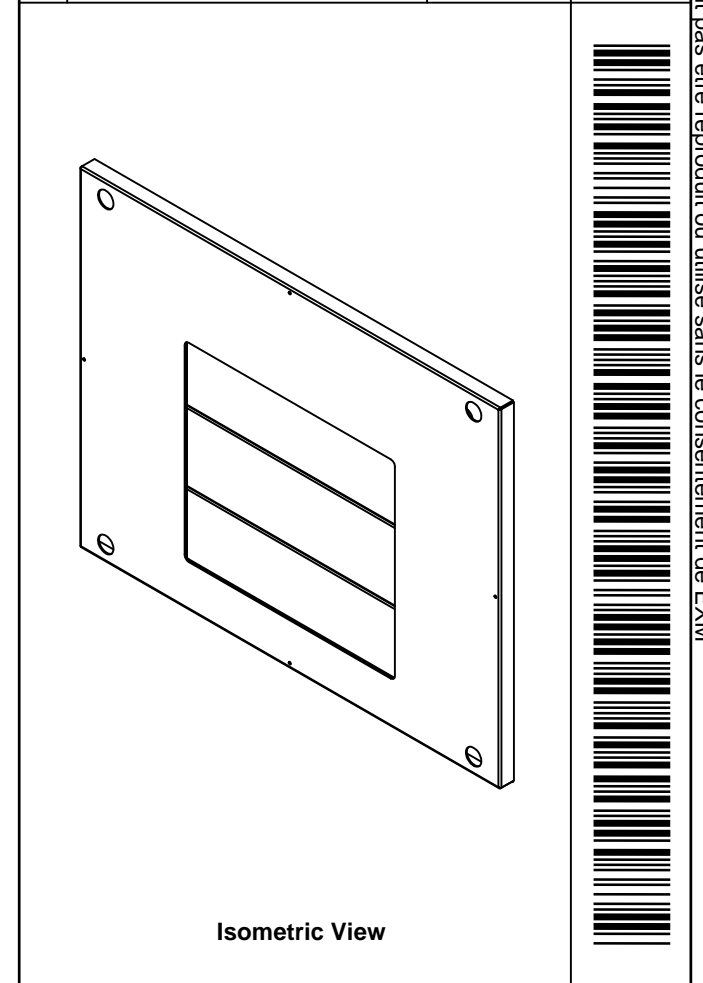

BOTTOM

No.	Revisions	Date	By/Par

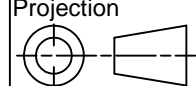

 Tél: (450) 979-4373 Fax: (450) 979-4626 www.exmweb.com		Flatness Aplatissement Max 3.0mm Projection 
Customer Client	Date	
Drawn By / Dessiné Par: BoxCad: Annie	Date: 10/02/2015	
Material / Matière: 16 Ga H.R.P. & O. (1.4mm)	Color / Couleur: Iron Grey RAL7011	
Description: 6500 MXB 600mm x 500mm Bottom		Finish / Fini: Rough / Textured
Part Number / Numéro Pièce: 6500MXK180605BT	Detail Rev.:	Rev. 1 / 3

SEE BILL OF MATERIAL ON LAST PAGE

This drawing is confidential and must not be reproduced or used without the consent of EXM

Ce dessin est confidentiel et ne doit pas être reproduit ou utilisé sans le consentement de EXM

STANDARD FEATURES ARE NOT LISTED IN THIS HOLE TABLE

HOLE TABLE - FRONT VIEW (CUSTOM FEATURE ONLY)

CUT-OUT	XDIM	YDIM	DESCRIPTION
1	110.0	234.5	GND STUD M6 x 16mm (Inside)
2	490.0	234.5	GND STUD M6 x 16mm (Inside)
3	130.0	294.5	GP STUD M6 x 10mm (Inside)
4	470.0	294.5	GP STUD M6 x 10mm (Inside)
5	130.0	194.5	GP STUD M6 x 10mm (Inside)
6	470.0	194.5	GP STUD M6 x 10mm (Inside)
7	130.0	94.5	GP STUD M6 x 10mm (Inside)
8	470.0	94.5	GP STUD M6 x 10mm (Inside)

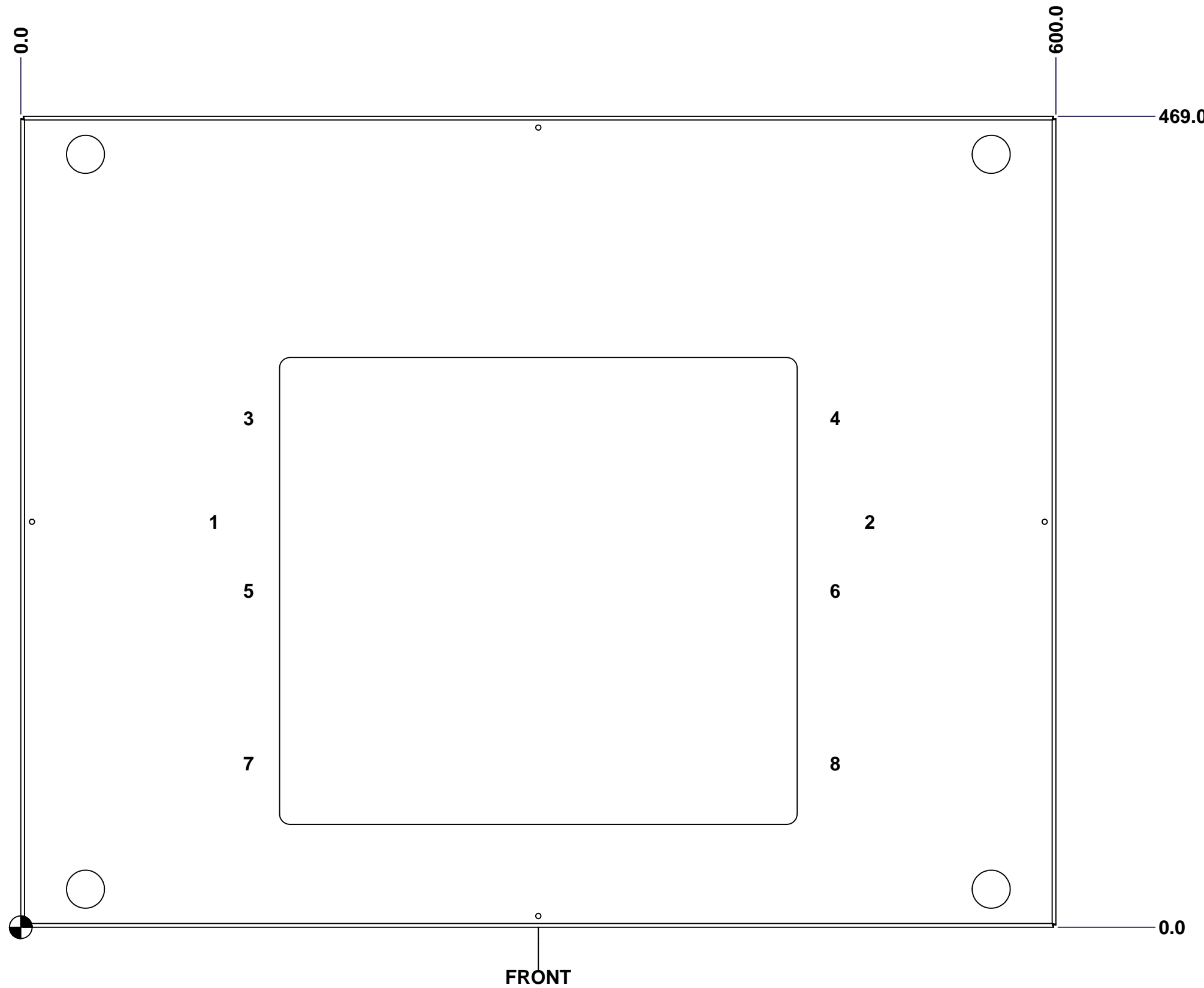

	Description	Status
	6500 MXB 600mm x 500mm Bottom	(NULL)
	Part Number Numéro Pièce	Rev.
	6500MXK180605BT	0
		2
		3

This drawing is confidential and must not be reproduced or used without the consent of EXM

Ce dessin est confidentiel et ne doit pas être reproduit ou utilisé sans le consentement de EXM

No.	Revisions	Date	By/Par

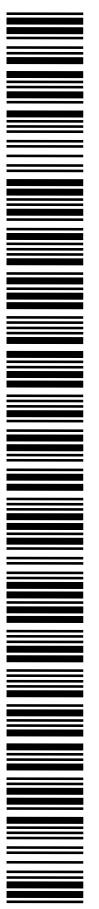
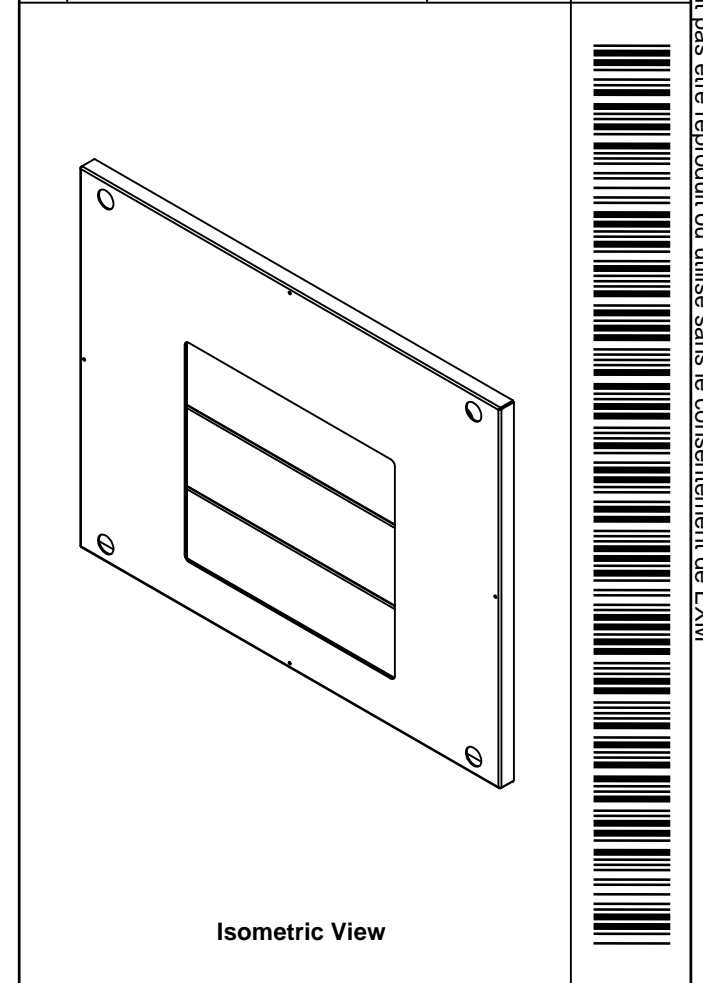

Tél: (450) 979-4373 Fax: (450) 979-4626 www.exmweb.com		Flatness Aplatissement	
		Max 3.0mm Projection	
Customer Client		Date	
Drawn By Dessiné Par		Date	
BoxCad: Annie		10/02/2015	
Material Matière		16 Ga H.R.P. & O. (1.4mm)	
Color Couleur		Iron Grey RAL7011	Finish Fini
			Rough Textured
Description			Detail Rev.
6500 MXB 600mm x 500mm Bottom			
Part Number Numéro Pièce		Rev.	3
6500MXK180605BT		0	3

Qty	Part Number	Rev	Description
1	STK-P-03810R	0	Powder Paint (Iron Grey / Rough Textured)
6	STK-Q-06001	0	Mtrx - Gland Plate M6 Plastic Thumb Nut
2	STK-Q-16055	1	M6 x 18mm Stud (No Paint Cap Required)
3	6500MXK180605GP100-P	0	6500 MXB 600mm Gland Plate Part (100mm)
6	STK-Q-16031	0	M6 x 10mm Stud (No Paint Cap Required)
1	6500MXK180605BTGPG	0	6500 MXB 600mm x 500mm Bottom Gland Plate Gasket
1	6500MXK180605BTG	0	6500 MXB 600mm x 500mm Bottom Gasket
1	6500MXK180605BT-P	0	6500 MXB 600mm x 500mm Bottom Part
Parts List			

This drawing is confidential and must not be reproduced or used without the consent of EXM

Ce dessin est confidentiel et ne doit pas être reproduit ou utilisé sans le consentement de EXM

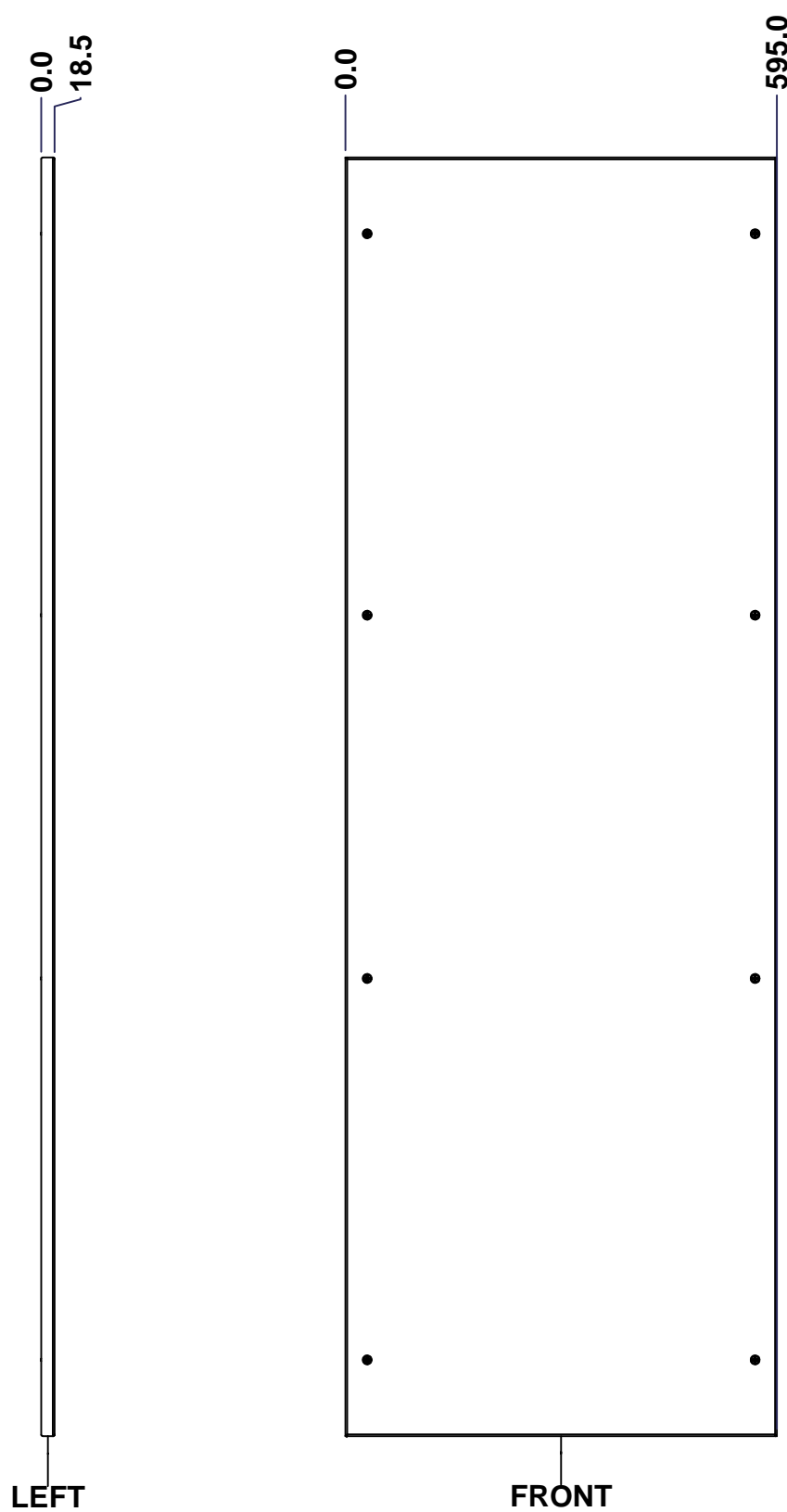
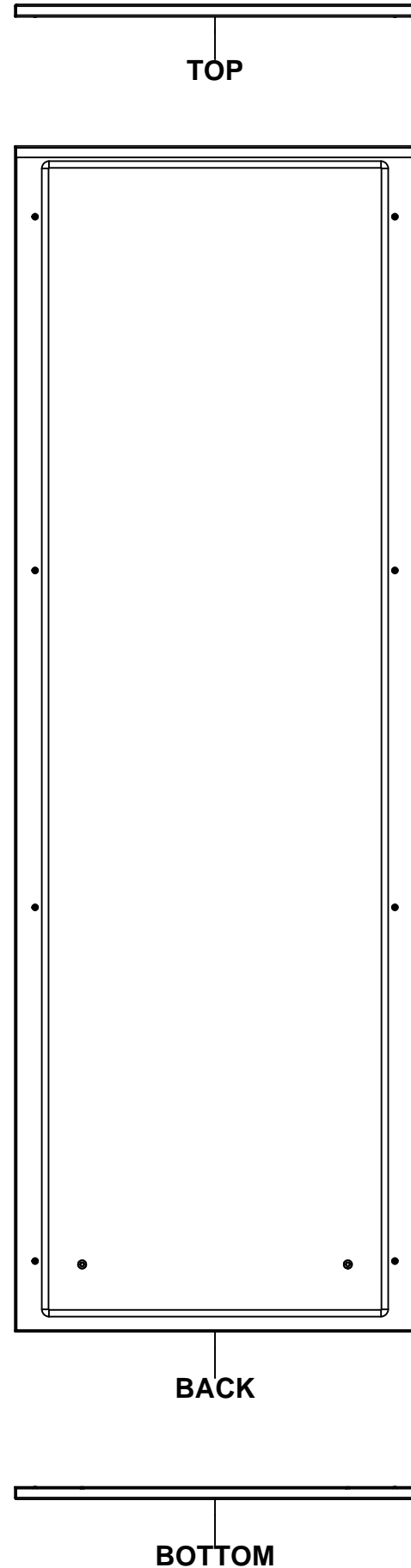

No.	Revisions	Date	By/Par

Isometric View

<p>Tél: (450) 979-4373 Fax: (450) 979-4626 www.exmweb.com</p>		Flatness Aplatissement	
		Max 3.0mm	
Customer Client		Projection	
Date			
Drawn By Dessiné Par		Date	
BoxCad: Annie		10/02/2015	
Material Matière		14 Ga H.R.P. & O. (1.7mm)	
Color Couleur		Finish Fin	
Light Grey RAL7035		Rough Textured	
Description		Detail Rev.	
6500 MXR 1800mm x 600mm Back			
Part Number Numéro Pièce		Rev.	
6500MXK180605B		0	
		1	
		3	

SEE BILL OF MATERIAL ON LAST PAGE

This drawing is confidential and must not be reproduced or used without the consent of EXM

Ce dessin est confidentiel et ne doit pas être reproduit ou utilisé sans le consentement de EXM

STANDARD FEATURES ARE NOT LISTED IN THIS HOLE TABLE			
HOLE TABLE - FRONT VIEW (CUSTOM FEATURE ONLY)			
CUT-OUT	XDIM	YDIM	DESCRIPTION
1	100.0	100.0	GND STUD M6 x 16mm (Inside)
2	495.0	100.0	GND STUD M6 x 16mm (Inside)

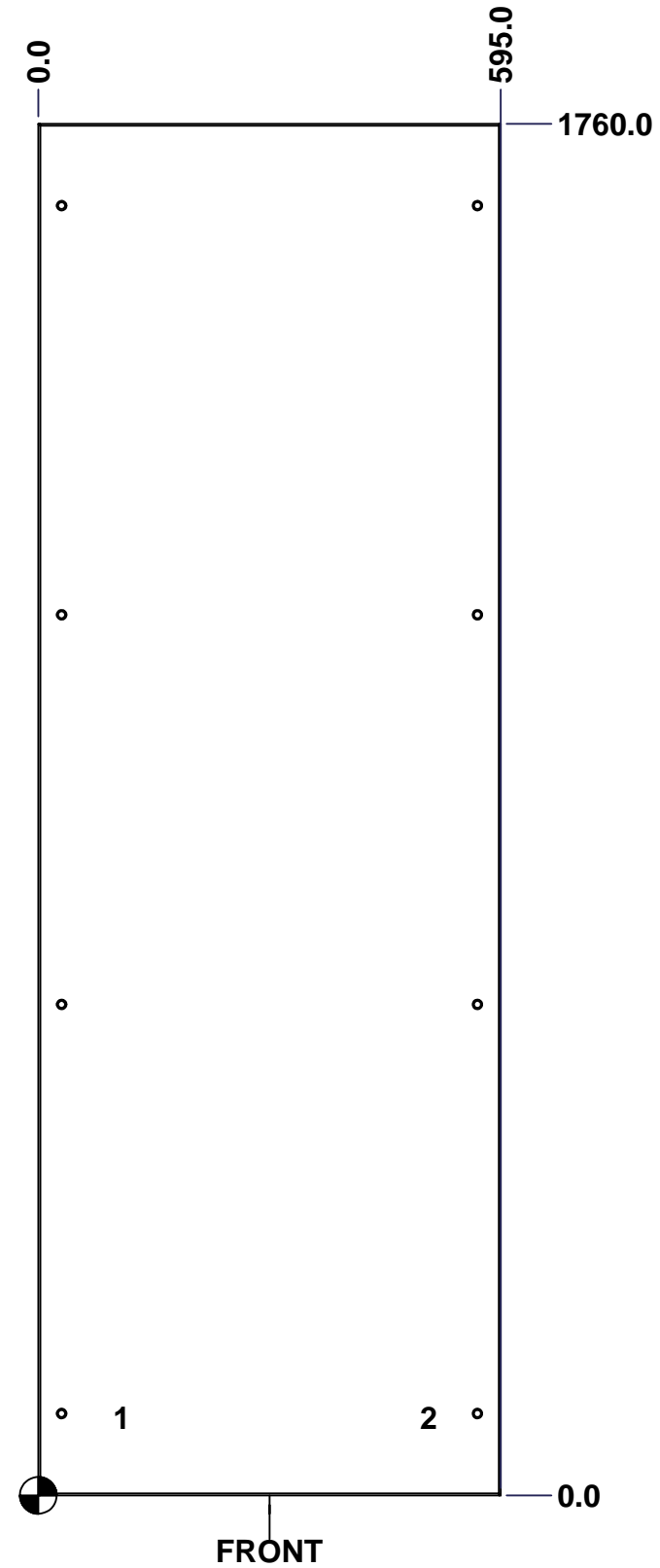



	Description 6500 MXR 1800mm x 600mm Back	Status (NULL)
	Part Number Numéro Pièce 6500MXK180605B	Rev. 2 0 / 3

This drawing is confidential and must not be reproduced or used without the consent of EXM

Ce dessin est confidentiel et ne doit pas être reproduit ou utilisé sans le consentement de EXM

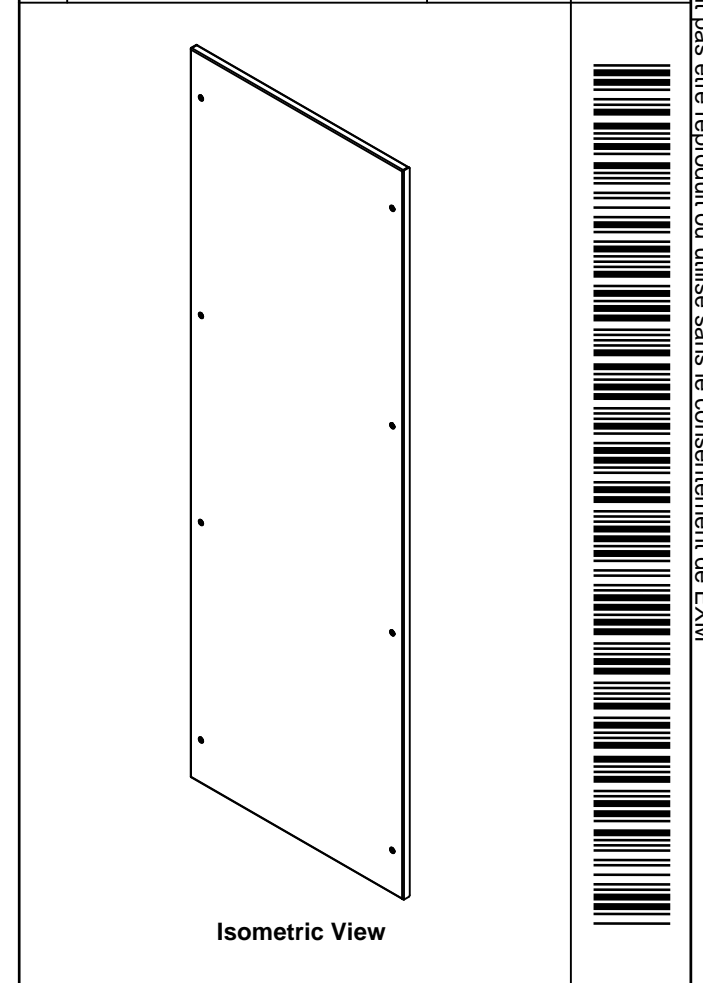
No.	Revisions	Date	By/Par

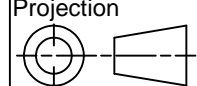

 Tél: (450) 979-4373 Fax: (450) 979-4626 www.exmweb.com		Flatness Aplatissement Max 3.0mm Projection 	
Customer Client		Date	
Drawn By / Dessiné Par: BoxCad: Annie		Date: 10/02/2015	
Material / Matière: 14 Ga H.R.P. & O. (1.7mm)			
Color / Couleur: Light Grey RAL7035		Finish / Fini: Rough Textured	
Description: 6500 MXR 1800mm x 600mm Back			Detail Rev.
Part Number / Numéro Pièce: 6500MXK180605B			Rev. 3

Qty	Part Number	Rev	Description
1	STK-P-03820R	0	Powder Paint (Light Grey / Rough Textured)
8	STK-Q-03072	2	M6 x 17mm Phillips Flat Head Screw
2	STK-Q-16080	0.1.1	M6 x 16mm Ground Stud
1	6500MXK180605BG	0	6500 MXR 1800mm x 600mm Back Gasket
1	6500MXK180605B-P	0	6500 MXR 1800mm x 600mm Back Part
Parts List			

This drawing is confidential and must not be reproduced or used without the consent of EXM

Ce dessin est confidentiel et ne doit pas être reproduit ou utilisé sans le consentement de EXM



TOP

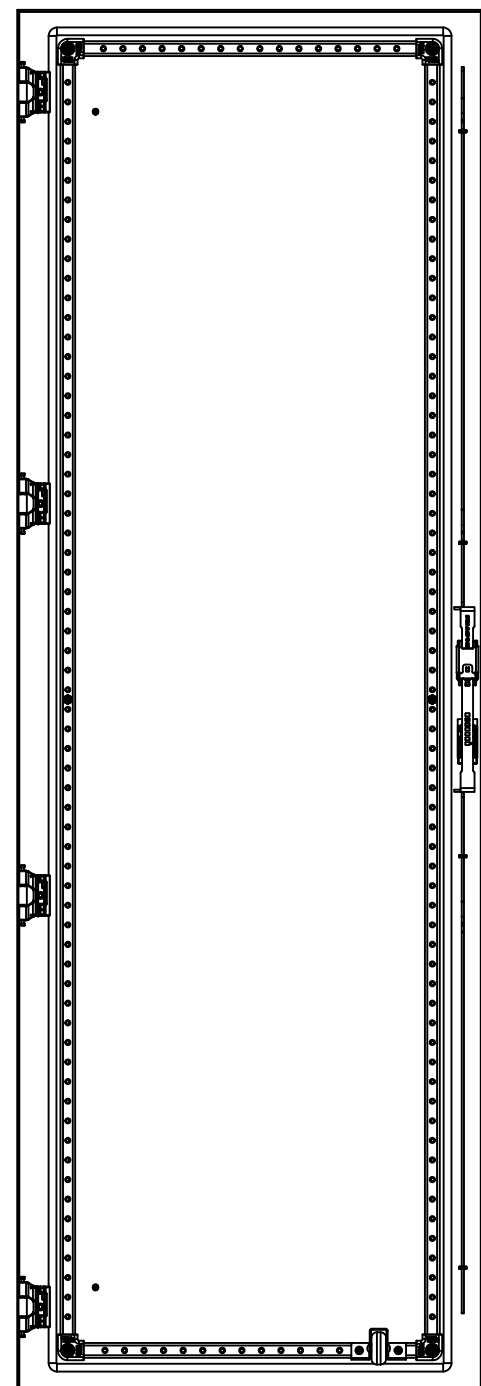

BACK



BOTTOM

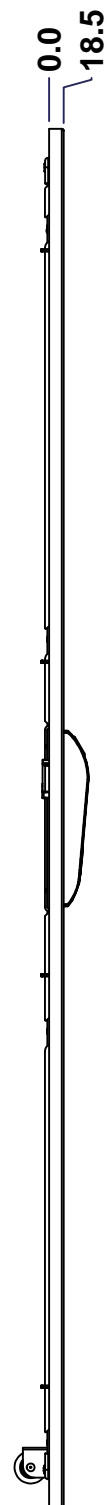

LEFT

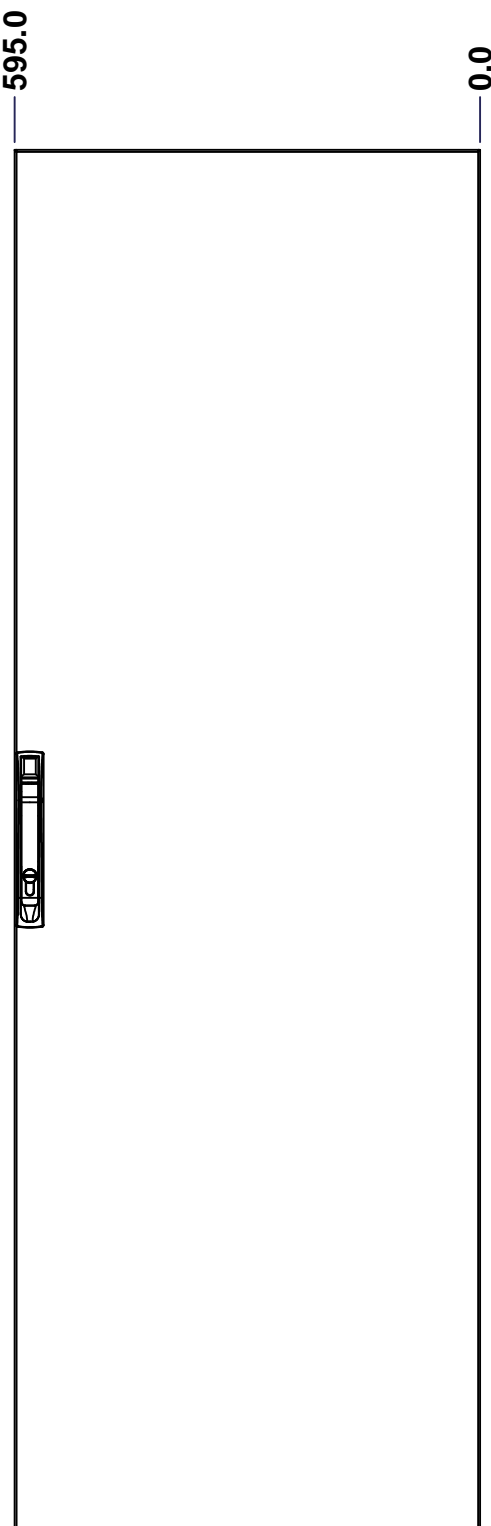

FRONT

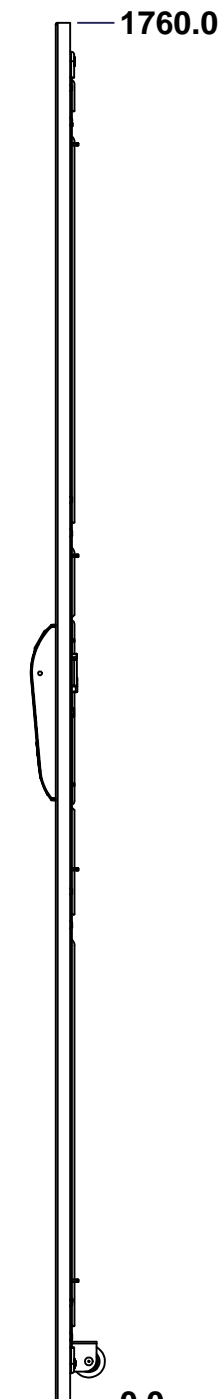

RIGHT

No.	Revisions	Date	By/Par

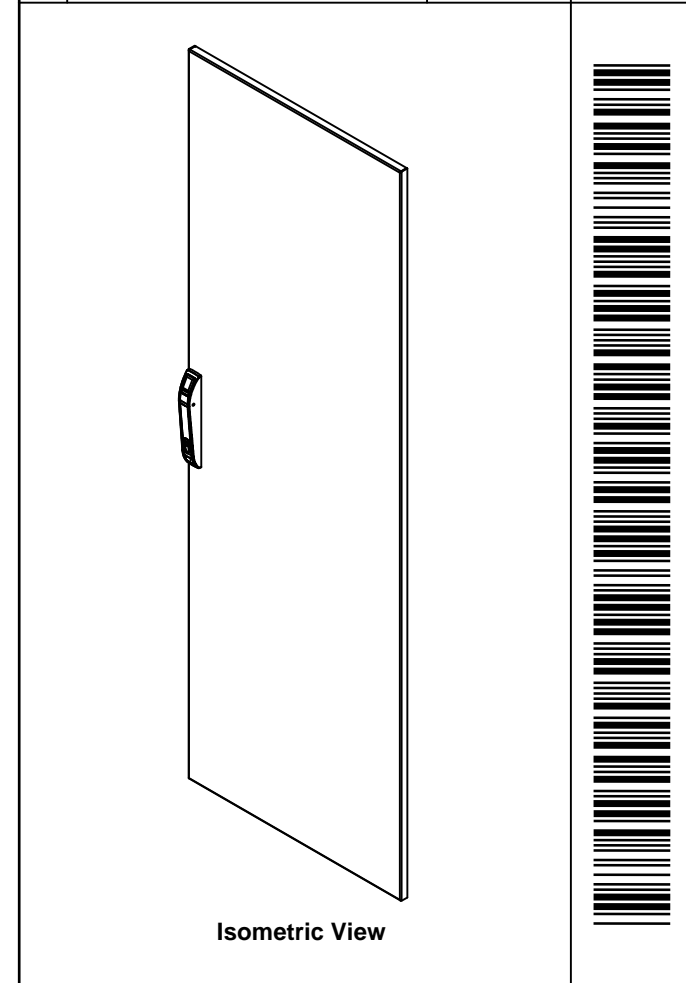

Isometric View

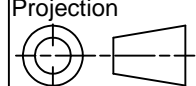
 Tél: (450) 979-4373 Fax: (450) 979-4626 www.exmweb.com		Flatness Aplatissement Max 3.0mm Projection 
Customer Client	Date	
Drawn By Dessiné Par	BoxCad: Annie	Date 10/02/2015
Material Matière	14 Ga H.R.P. & O. (1.7mm)	
Color Couleur	Light Grey RAL7035	Finish Fin Rough Textured
Description		Detail Rev.
6500 MXD 1800mm x 600mm Front		
Part Number Numéro Pièce	Rev.	
6500MXK180605F	0	1 / 3

SEE BILL OF MATERIAL ON LAST PAGE

This drawing is confidential and must not be reproduced or used without the consent of EXM

Ce dessin est confidentiel et ne doit pas être reproduit ou utilisé sans le consentement de EXM

STANDARD FEATURES ARE NOT LISTED IN THIS HOLE TABLE

HOLE TABLE - FRONT VIEW (CUSTOM FEATURE ONLY)

CUT-OUT	XDIM	YDIM	DESCRIPTION
1	100.0	130.0	GND STUD M6 x 16mm (Inside)
2	100.0	1630.0	GND STUD M6 x 16mm (Inside)
3	64.5	49.5	STIFF. STUD M6 x 18mm (Inside)
4	64.5	880.0	STIFF. STUD M6 x 18mm (Inside)
5	64.5	1710.5	STIFF. STUD M6 x 18mm (Inside)
6	530.5	49.5	STIFF. STUD M6 x 18mm (Inside)
7	530.5	880.0	STIFF. STUD M6 x 18mm (Inside)
8	530.5	1710.5	STIFF. STUD M6 x 18mm (Inside)
9	569.5	155.0	CLOSING BAR GUIDE (Inside)
10	569.5	1605.0	CLOSING BAR GUIDE (Inside)
11	569.5	680.0	CLOSING BAR GUIDE (Inside)
12	569.5	1080.0	CLOSING BAR GUIDE (Inside)

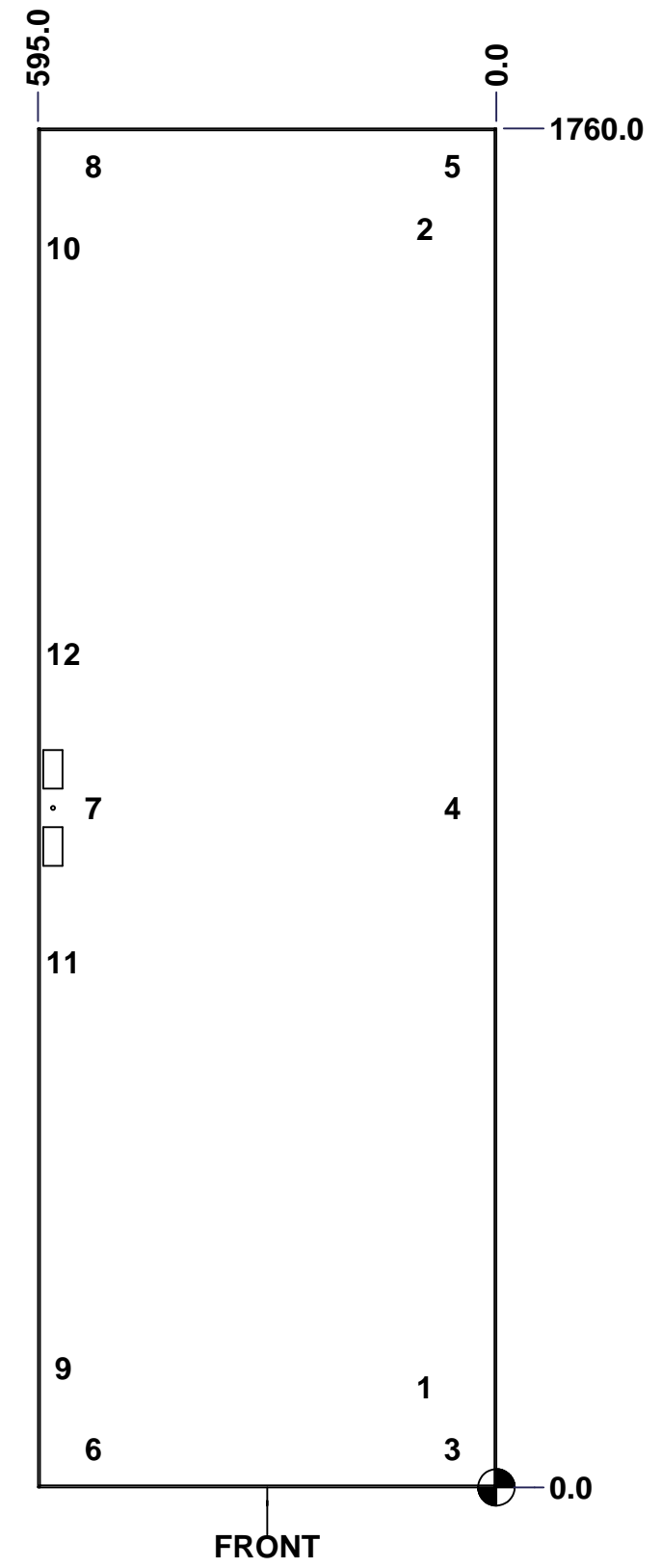

	Description 6500 MXD 1800mm x 600mm Front	Status (NULL)
	Part Number Numéro Pièce 6500MXK180605F	Rev. 2 0

This drawing is confidential and must not be reproduced or used without the consent of EXM

Ce dessin est confidentiel et ne doit pas être reproduit ou utilisé sans le consentement de EXM

No.	Revisions	Date	By/Par

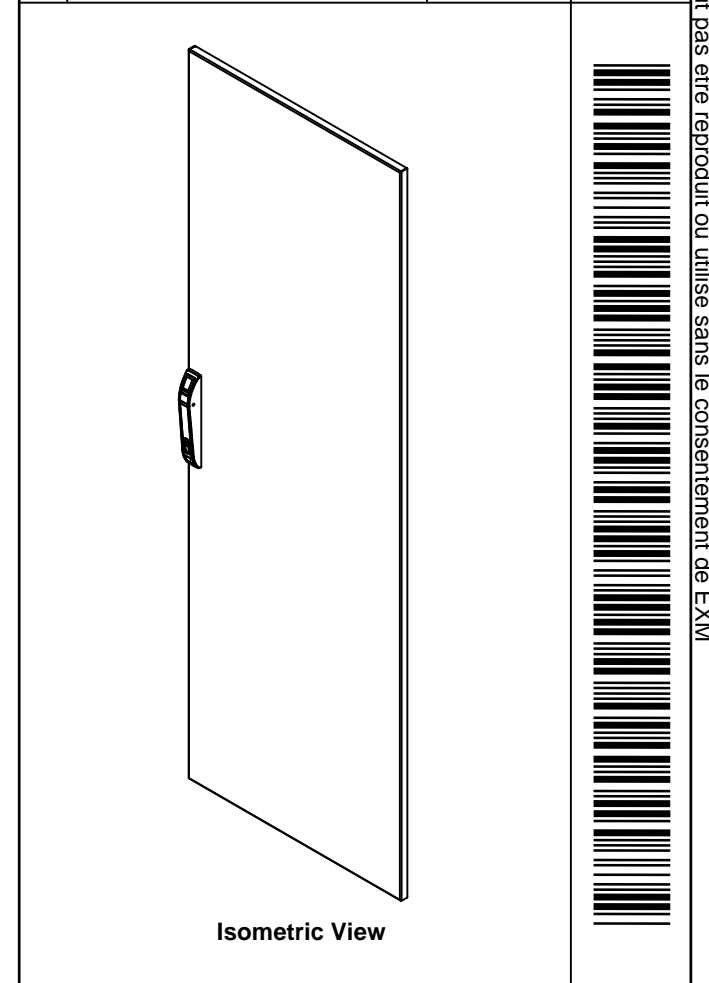

1	STK-P-03820R	0	Powder Paint (Light Grey / Rough Textured)
1	6500MXSRK	1	6500 MXRSK Door Support Roller
4	STK-Q-78022	0	Mtrx Closing Bar Slider
1	STK-Q-45746-18	1	6500 MXD - Lock Door Closing Bar
4	STK-Q-33105	4	5412 ESBU Buttable Hinge (Cover Part)
1	STK-Q-45729-18	2	6500 MXD - Lock Door Top Closing Bar
1	886PHD-S	4	Euroform Pull Handle Kit
8	STK-Q-16055	1	M6 x 18mm Stud (No Paint Cap Required)
1	6500MXK180605DS1	5	6500 MX 1800mm x 600mm Door Stiffener
1	6500MXK180605FG	0	6500 MXD 1800mm x 600mm Front Gasket
1	6500MXK180605F-P	0	6500 MXD 1800mm x 600mm Front Part
4	STK-K-06811	1	6500 MX - Hinge Assy
Qty	Part Number	Rev	Description
Parts List			

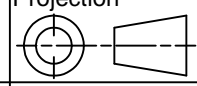
 Tél: (450) 979-4373 Fax: (450) 979-4626 www.exmweb.com		Flatness Aplatissement Max 3.0mm Projection 
Customer Client	Date	Date 10/02/2015
Drawn By Dessiné Par	BoxCad: Annie	
Material Matière	14 Ga H.R.P. & O. (1.7mm)	
Color Couleur	Light Grey RAL7035	Finish Fini Rough Textured
Description	6500 MXD 1800mm x 600mm Front	
Part Number Numéro Pièce	Rev. 0	3 / 3
6500MXK180605F		

This drawing is confidential and must not be reproduced or used without the consent of EXM

Ce dessin est confidentiel et ne doit pas être reproduit ou utilisé sans le consentement de EXM

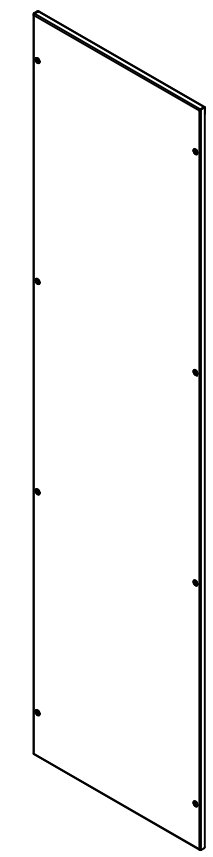
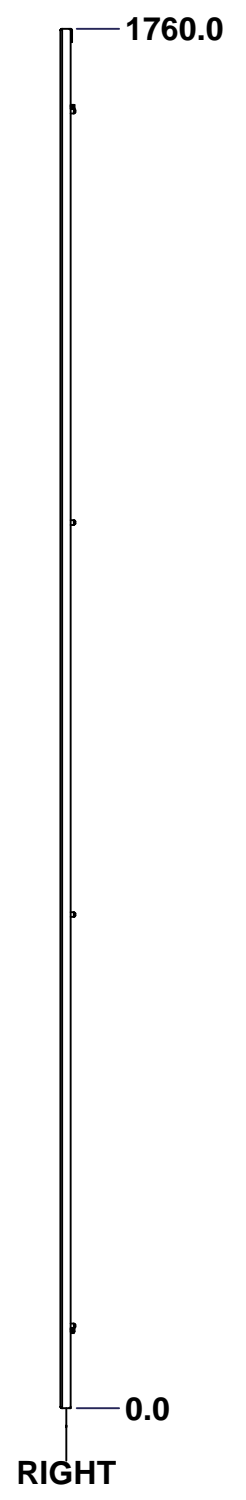
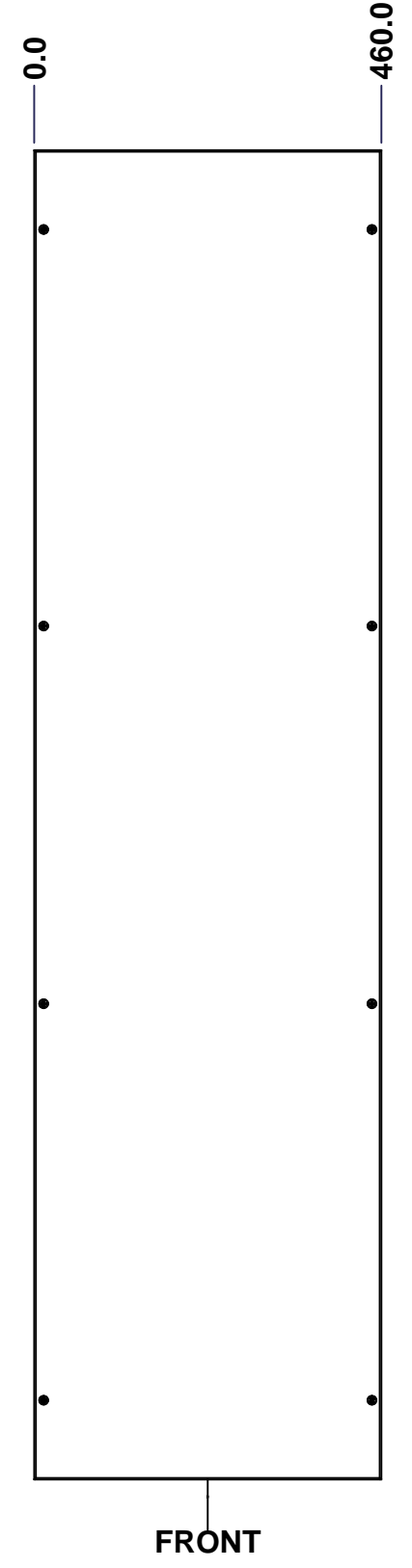
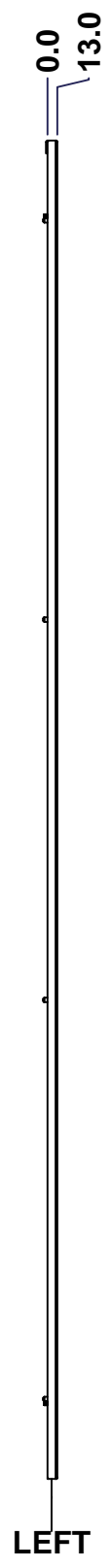
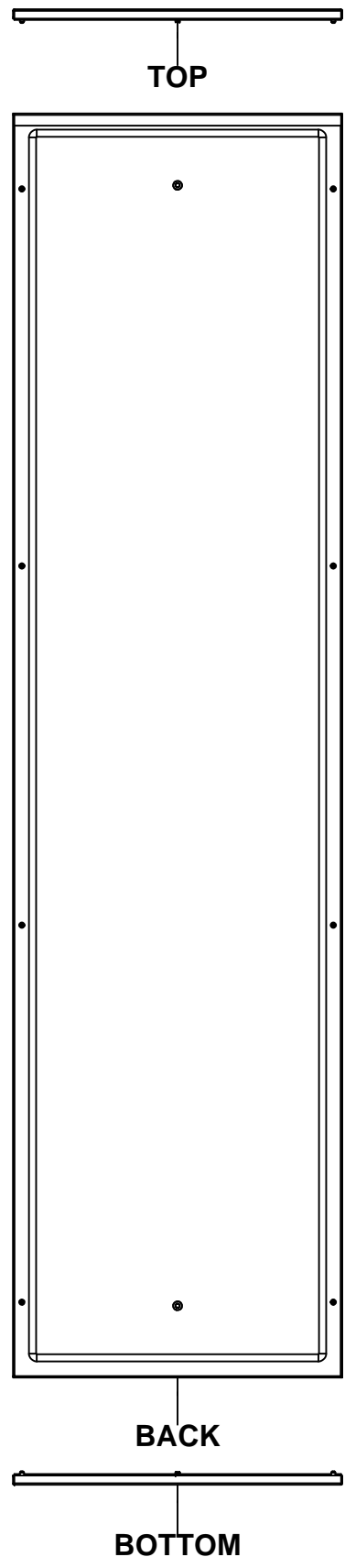

Isometric View

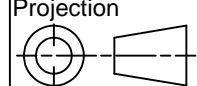

No.	Revisions	Date	By/Par

 Tél: (450) 979-4373 Fax: (450) 979-4626 www.exmweb.com		Flatness Aplatissement Max 3.0mm Projection 
Customer Client	Date	
Drawn By Dessiné Par	BoxCad: Annie	Date 10/02/2015
Material Matière	16 Ga H.R.P. & O. (1.4mm)	
Color Couleur	Light Grey RAL7035	Finish Fini Rough Textured
Description 6500 MXC 1800mm x 500mm Left		Detail Rev.
Part Number Numéro Pièce	Rev. 0	1 3

SEE BILL OF MATERIAL ON LAST PAGE

6500MXK180605L

This drawing is confidential and must not be reproduced or used without the consent of EXM

Ce dessin est confidentiel et ne doit pas être reproduit ou utilisé sans le consentement de EXM

STANDARD FEATURES ARE NOT LISTED IN THIS HOLE TABLE			
HOLE TABLE - FRONT VIEW (CUSTOM FEATURE ONLY)			
CUT-OUT	XDIM	YDIM	DESCRIPTION
1	230.0	100.0	GND STUD M6 x 16mm (Inside)
2	230.0	1660.0	GND STUD M6 x 16mm (Inside)

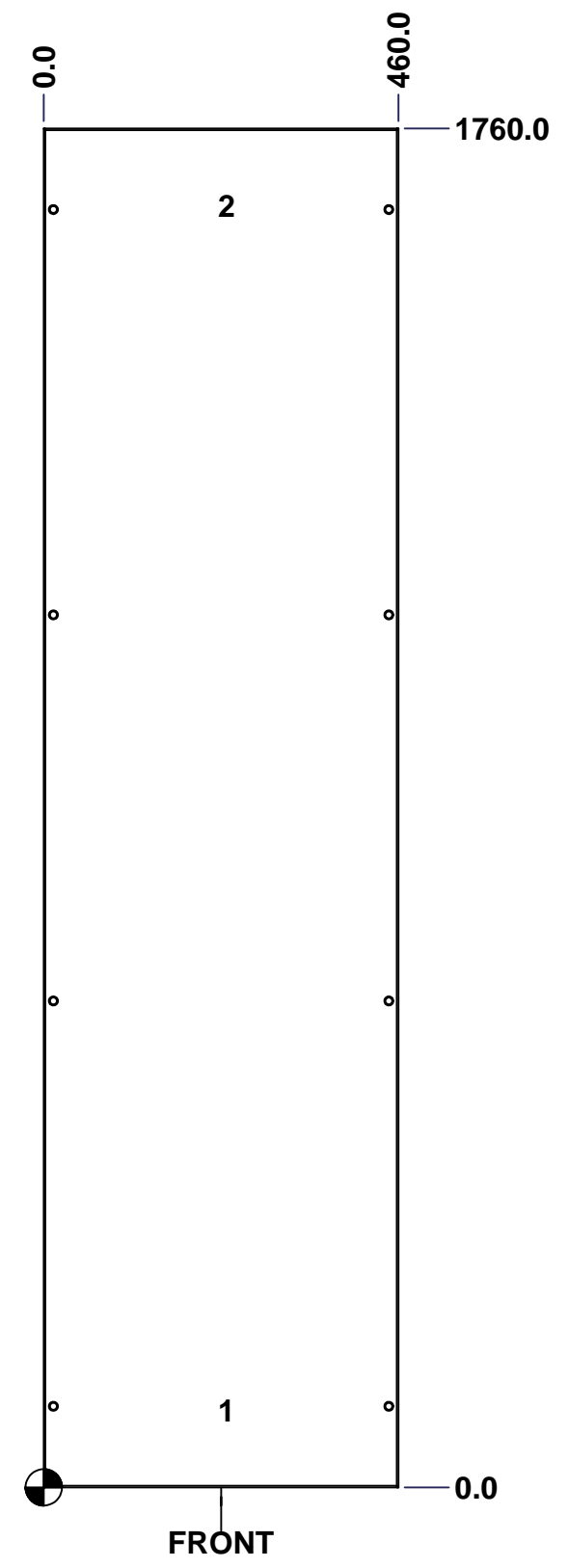



	Description	Status	
	6500 MXC 1800mm x 500mm Left	(NULL)	
	Part Number Numéro Pièce	Rev.	
	6500MXK180605L	0	2 3

This drawing is confidential and must not be reproduced or used without the consent of EXM

Ce dessin est confidentiel et ne doit pas être reproduit ou utilisé sans le consentement de EXM

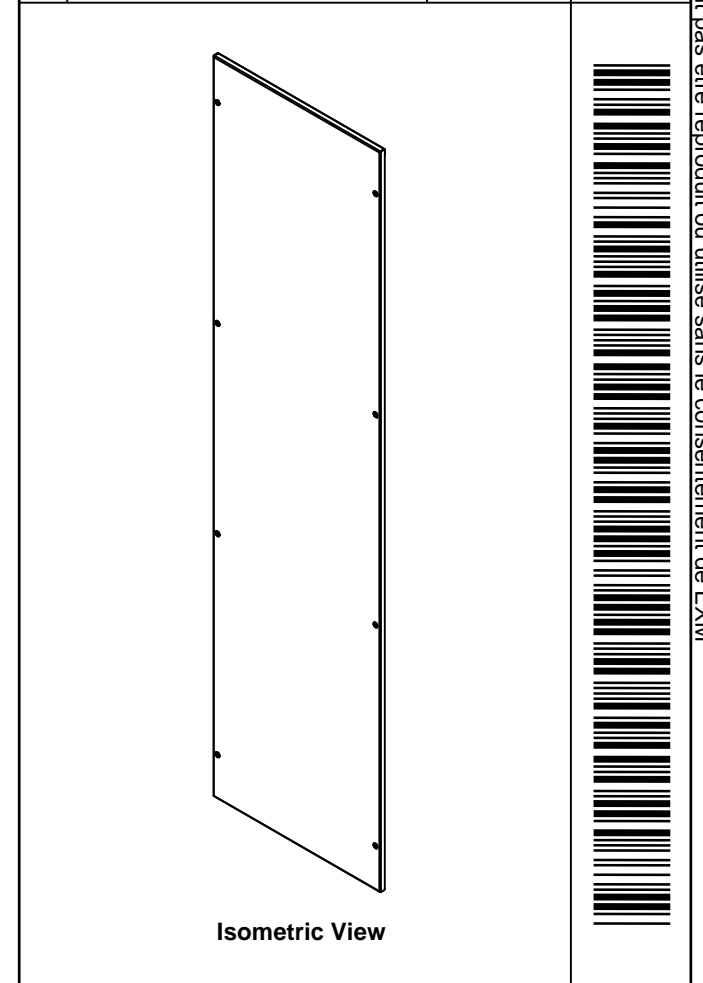
No.	Revisions	Date	By/Par

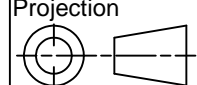

 Tél: (450) 979-4373 Fax: (450) 979-4626 www.exmweb.com		Flatness Aplatissement Max 3.0mm Projection 
Customer Client	Date	
Drawn By Dessiné Par	BoxCad: Annie	Date 10/02/2015
Material Matière	16 Ga H.R.P. & O. (1.4mm)	
Color Couleur	Light Grey RAL7035	Finish Fini Rough Textured
Description	Detail Rev.	
6500 MXC 1800mm x 500mm Left		
Part Number Numéro Pièce	Rev.	3
6500MXK180605L	0	3

Qty	Part Number	Rev	Description
1	STK-P-03820R	0	Powder Paint (Light Grey / Rough Textured)
8	STK-Q-03072	2	M6 x 17mm Phillips Flat Head Screw
2	STK-Q-16080	0.1.1	M6 x 16mm Ground Stud
1	6500MXK180605LG	0	6500 MXC 1800mm x 500mm Left Gasket
1	6500MXK180605L-P	0	6500 MXC 1800mm x 500mm Left Part
Parts List			

This drawing is confidential and must not be reproduced or used without the consent of EXM

Ce dessin est confidentiel et ne doit pas être reproduit ou utilisé sans le consentement de EXM

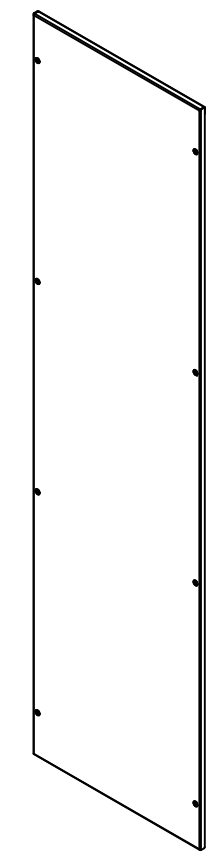
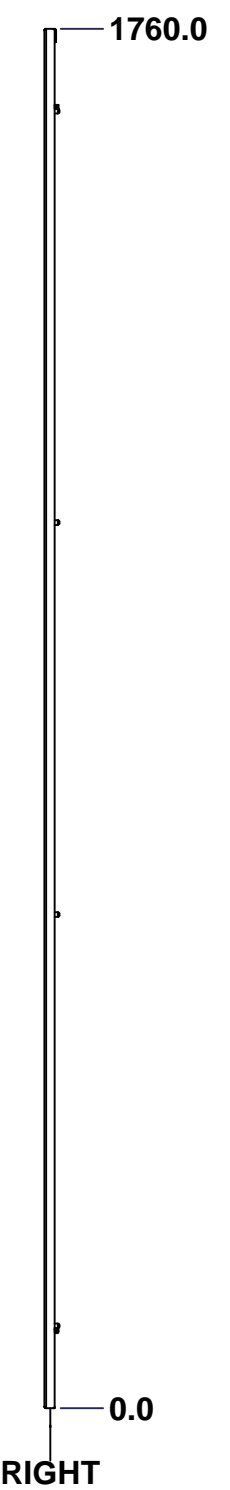
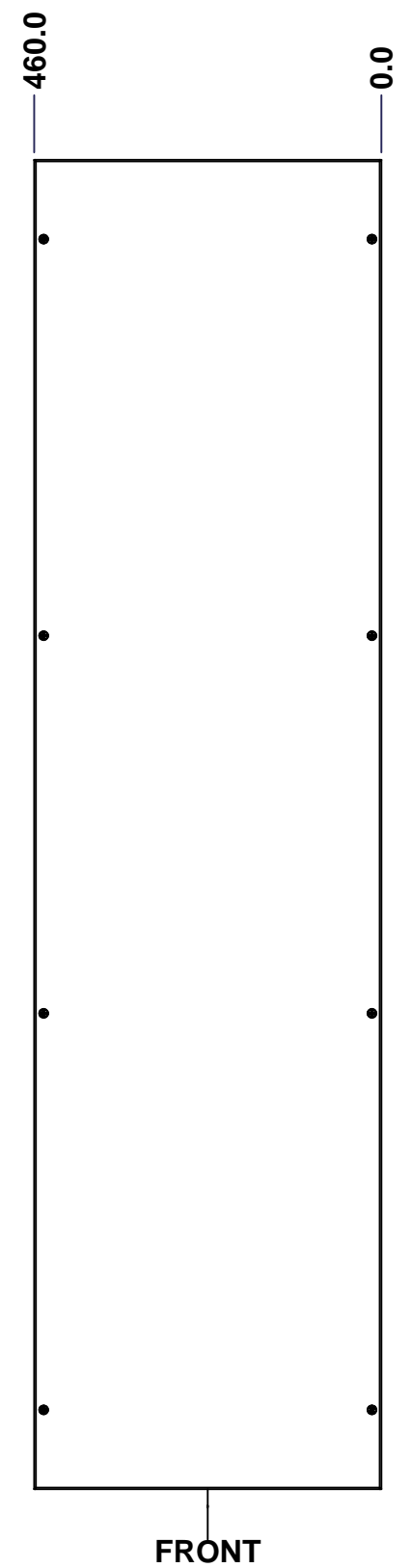
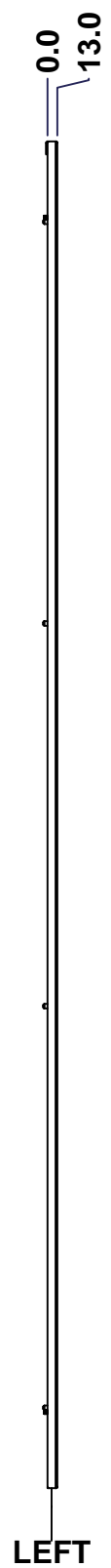
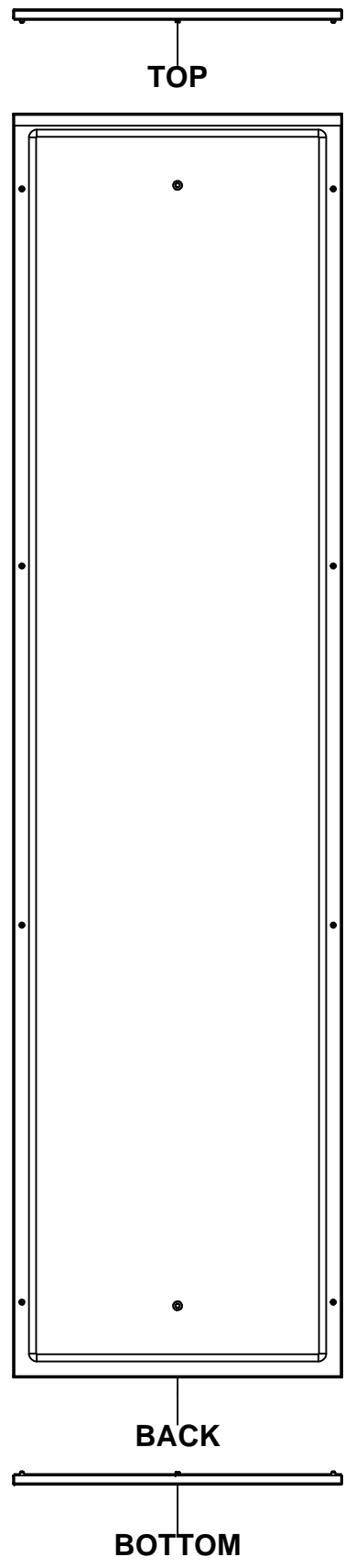

Isometric View

No.	Revisions	Date	By/Par

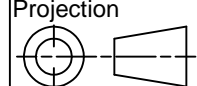

 Tél: (450) 979-4373 Fax: (450) 979-4626 www.exmweb.com		Flatness Aplatissement Max 3.0mm Projection 
Customer Client	Date	Date 10/02/2015
Drawn By Dessiné Par	BoxCad: Annie	
Material Matière	16 Ga H.R.P. & O. (1.4mm)	
Color Couleur	Light Grey RAL7035	Finish Fin Rough Textured
Description	Detail Rev.	
6500 MXC 1800mm x 500mm Right		
Part Number Numéro Pièce	Rev.	1 3
6500MXK180605R	0	

SEE BILL OF MATERIAL ON LAST PAGE

This drawing is confidential and must not be reproduced or used without the consent of EXM

Ce dessin est confidentiel et ne doit pas être reproduit ou utilisé sans le consentement de EXM

STANDARD FEATURES ARE NOT LISTED IN THIS HOLE TABLE			
HOLE TABLE - FRONT VIEW (CUSTOM FEATURE ONLY)			
CUT-OUT	XDIM	YDIM	DESCRIPTION
1	230.0	100.0	GND STUD M6 x 16mm (Inside)
2	230.0	1660.0	GND STUD M6 x 16mm (Inside)

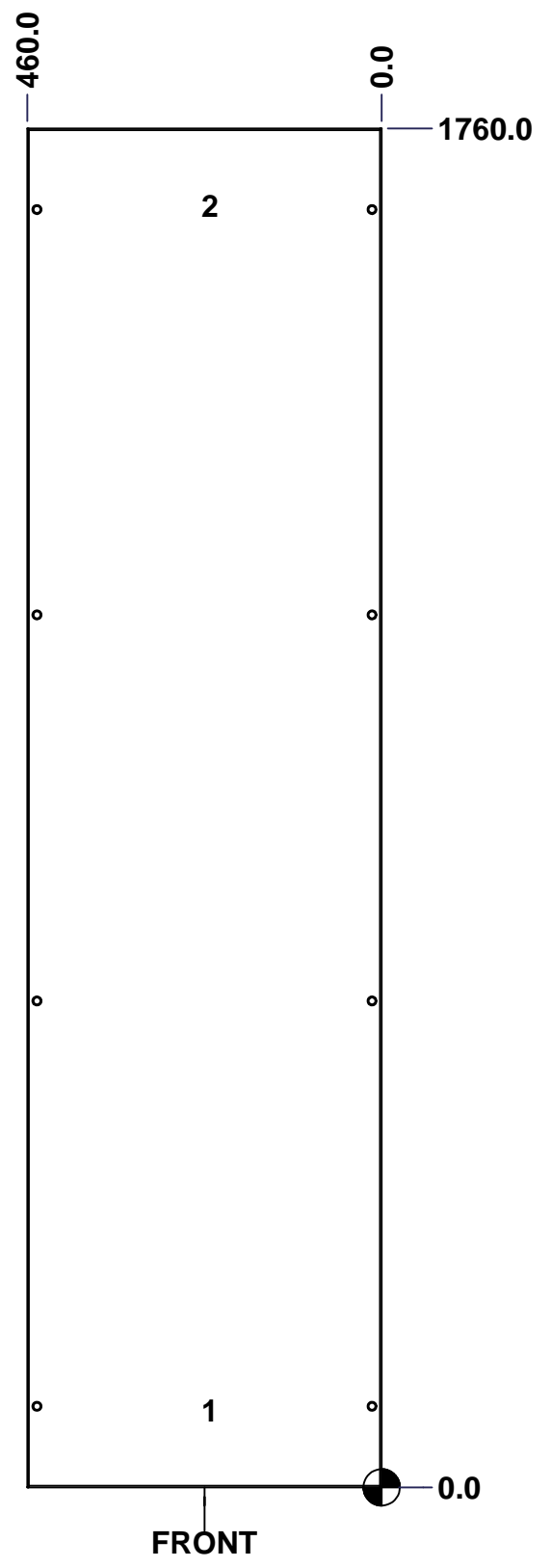

	Description 6500 MXC 1800mm x 500mm Right	Status (NULL)
	Part Number Numéro Pièce 6500MXK180605R	Rev. 2 0 / 3

This drawing is confidential and must not be reproduced or used without the consent of EXM

Ce dessin est confidentiel et ne doit pas être reproduit ou utilisé sans le consentement de EXM

No.	Revisions	Date	By/Par

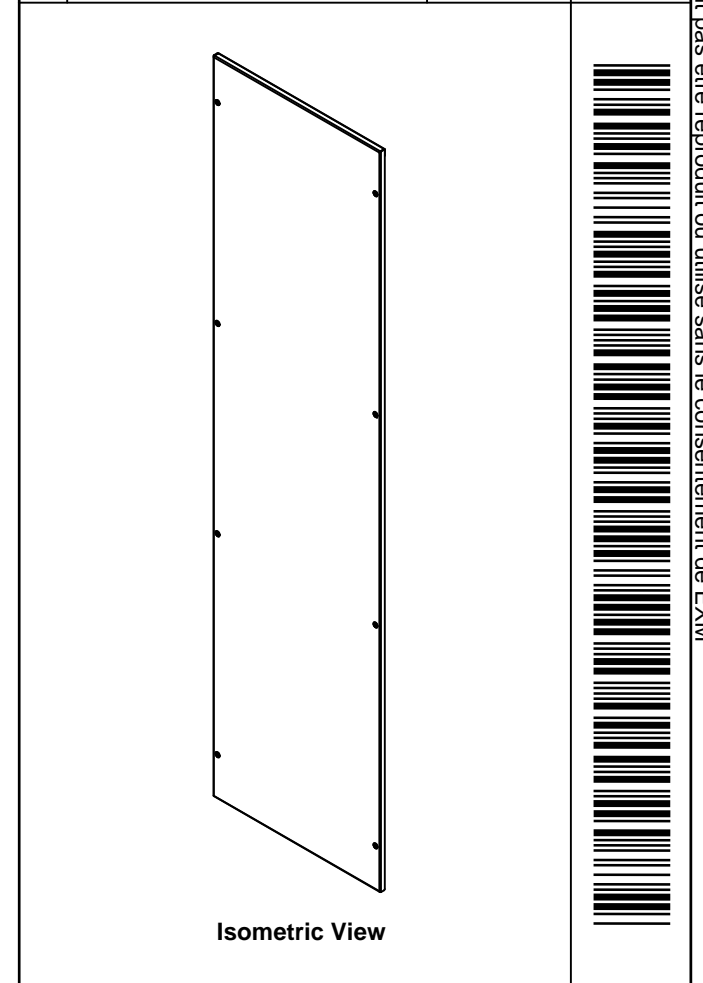

Tél: (450) 979-4373 Fax: (450) 979-4626 www.exmweb.com		Flatness Aplatissement	
		Max 3.0mm Projection	
Customer Client		Date	
Drawn By Dessiné Par BoxCad: Annie		Date 10/02/2015	
Material Matière 16 Ga H.R.P. & O. (1.4mm)			
Color Couleur Light Grey RAL7035		Finish Fini Rough Textured	
Description 6500 MXC 1800mm x 500mm Right			Detail Rev.
Part Number Numéro Pièce 6500MXK180605R		Rev. 0	3 3

Qty	Part Number	Rev	Description
1	STK-P-03820R	0	Powder Paint (Light Grey / Rough Textured)
8	STK-Q-03072	2	M6 x 17mm Phillips Flat Head Screw
2	STK-Q-16080	0.1.1	M6 x 16mm Ground Stud
1	6500MXK180605RG	0	6500 MXC 1800mm x 500mm Right Gasket
1	6500MXK180605R-P	0	6500 MXC 1800mm x 500mm Right Part
Parts List			

This drawing is confidential and must not be reproduced or used without the consent of EXM

Ce dessin est confidentiel et ne doit pas être reproduit ou utilisé sans le consentement de EXM

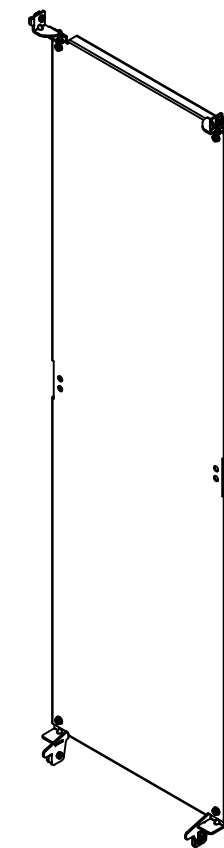
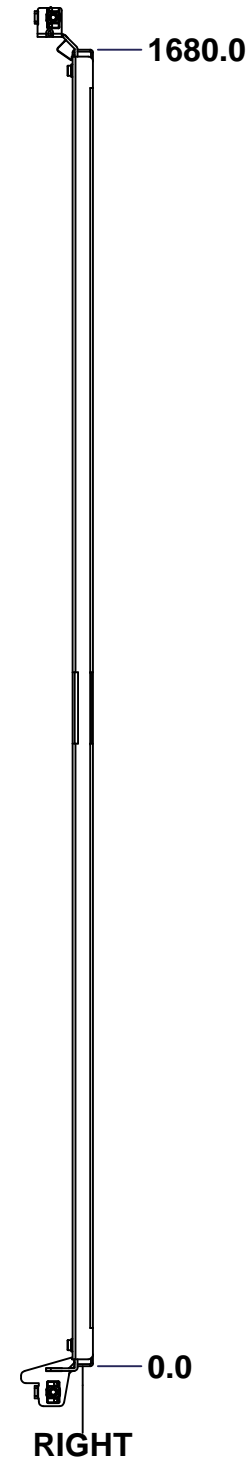
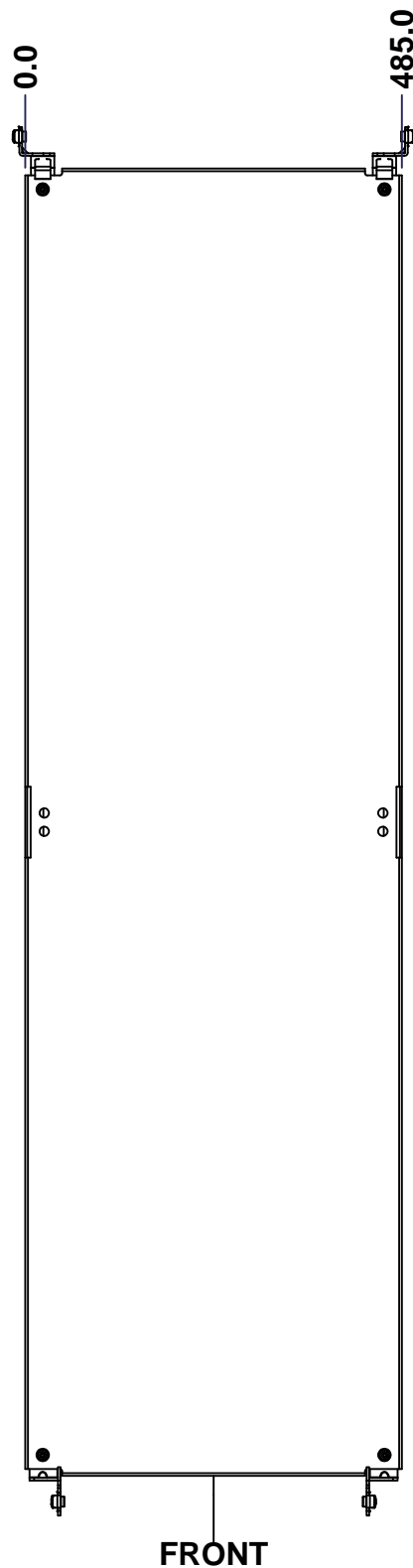
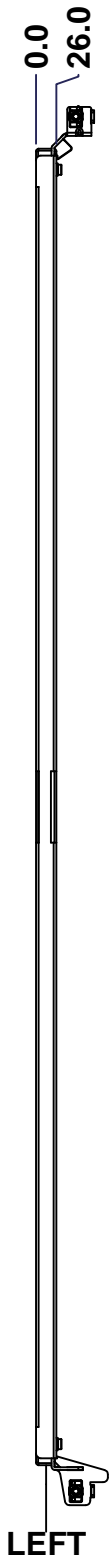
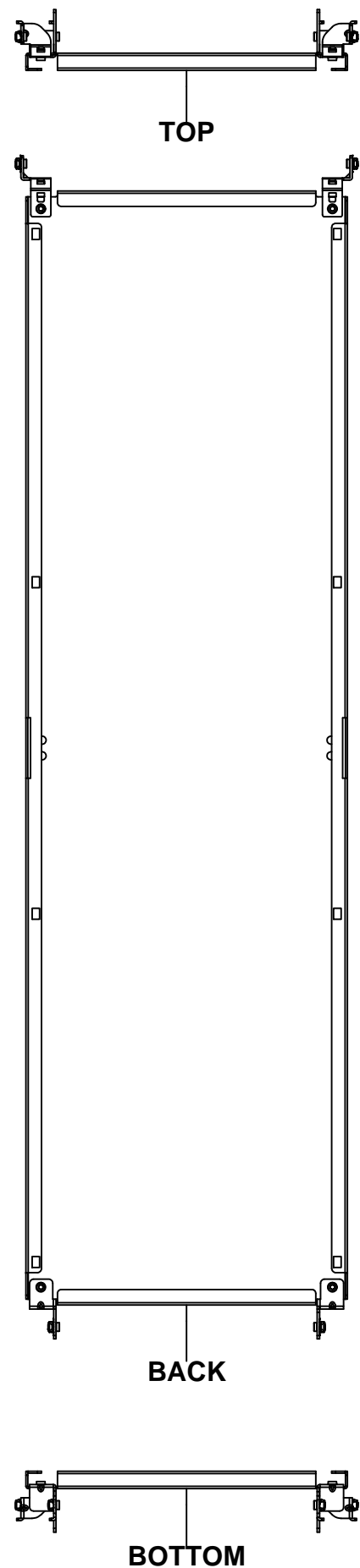

Isometric View

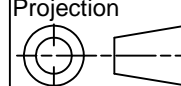

No.	Revisions	Date	By/Par

 Tél: (450) 979-4373 Fax: (450) 979-4626 www.exmweb.com		Flatness Aplatissement Max 3.0mm Projection 
Customer Client	Date	
Drawn By Dessiné Par	BoxCad: Annie	Date 10/02/2015
Material Matière	12 Ga Galvanized (2.5mm)	
Color Couleur	Unpainted	Finish Finis Unpainted
Description	Detail Rev.	
6500 MXM 1800mm x 600mm Back Inner Panel		
Part Number Numéro Pièce	Rev.	
6500MXK180605BIP	0	1 / 3

SEE BILL OF MATERIAL ON LAST PAGE

This drawing is confidential and must not be reproduced or used without the consent of EXM

Ce dessin est confidentiel et ne doit pas être reproduit ou utilisé sans le consentement de EXM

No.	Revisions	Date	By/Par

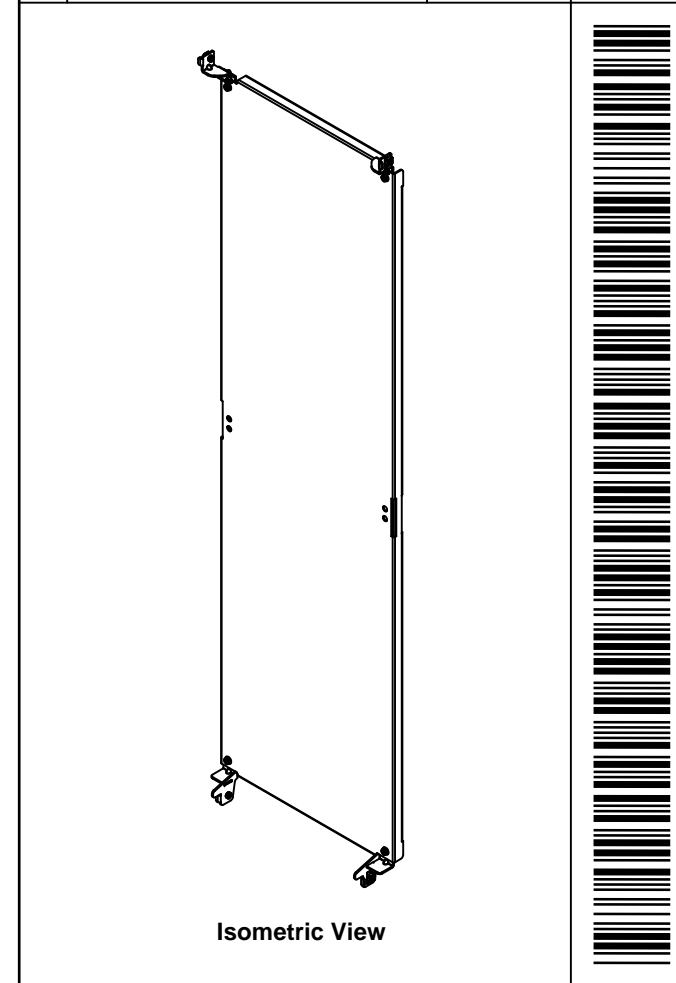

Tél: (450) 979-4373 Fax: (450) 979-4626 www.exmweb.com		Flatness Aplatissement	
		Max 3.0mm Projection	
Customer Client		Date	
Drawn By Dessiné Par		Date	
BoxCad: Annie		10/02/2015	
Material Matière		12 Ga Galvanized (2.5mm)	
Color Couleur		Unpainted	
Finish Fini		Unpainted	
Description 6500 MXM 1800mm x 600mm Back Inner Panel			Detail Rev.
Part Number Numéro Pièce			Rev.
6500MXK180605BIP			0
			3

Qty	Part Number	Rev	Description
1	STK-A-49005	0	6500MXM - Bottom Inner Panel Support Kit (Right)
1	STK-A-49000	0	6500MXM - Bottom Inner Panel Support Kit (Left)
1	STK-A-49015	0	6500MXM - Top Inner Panel Support Kit (Right)
1	STK-A-49010	0	6500MXM - Top Inner Panel Support Kit (Left)
1	6500MXK180605BIP-P	0	6500 MXM 1800mm x 600mm Back Inner Panel Part
Parts List			