

This drawing is confidential and must not be reproduced or used without the consent of EXM

Ce dessin est confidentiel et ne doit pas être reproduit ou utilisé sans le consentement de EXM

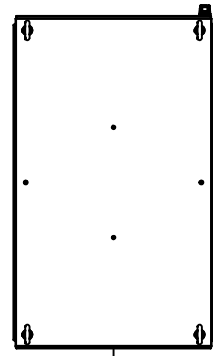

TOP

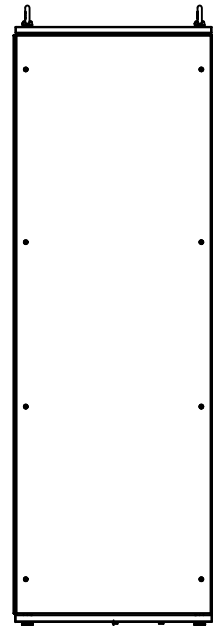

BACK

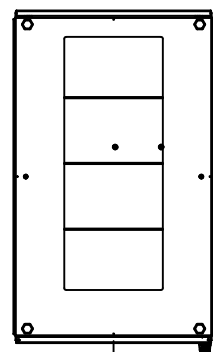

BOTTOM

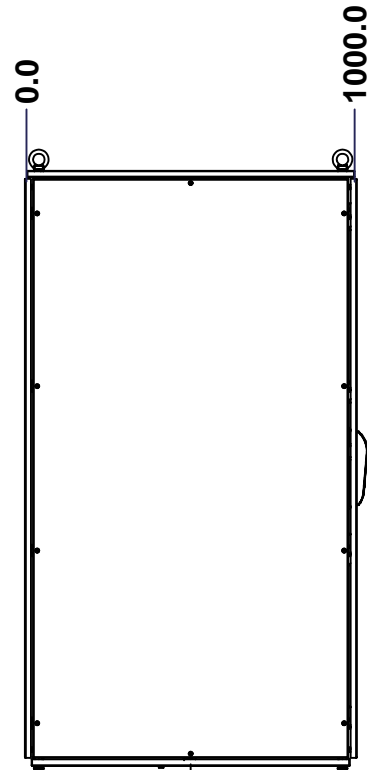

LEFT

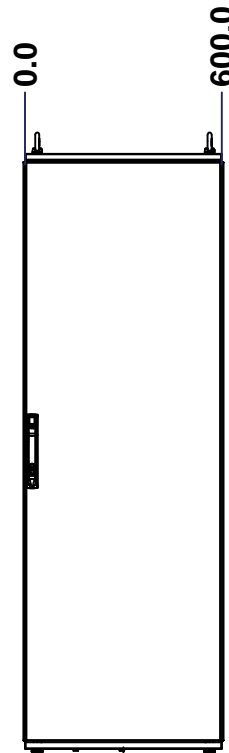

FRONT

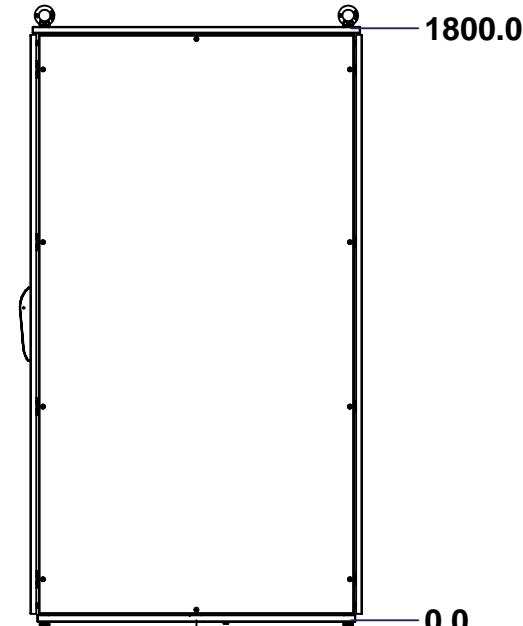

RIGHT

No.	Revisions	Date	By/Par

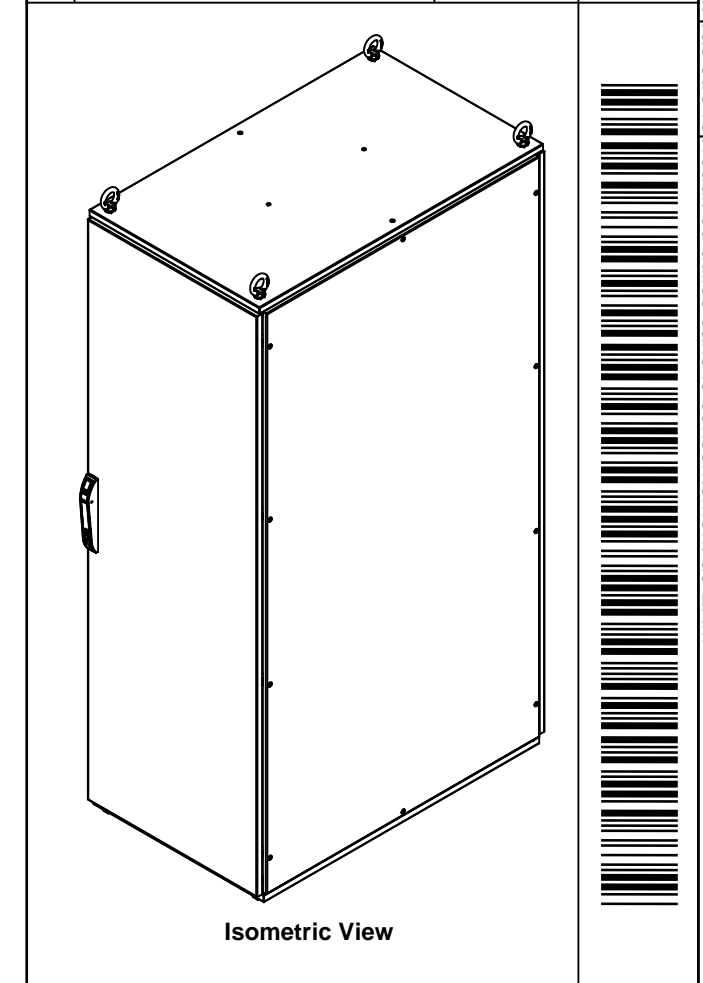

Isometric View

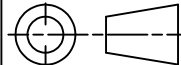

 Tél: (450) 979-4373 Fax: (450) 979-4626 <a href="http://www.exmweb.com">www.exmweb.com</a>		Flatness Aplatissement Max 3.0mm Projection 
Customer Client	Date	Date
Drawn By Dessiné Par	BoxCad: Annie	Date 12/02/2015
Material Matière	See Part List	
Color Couleur	See Part List	Finish Fini See Part List
Description 6500MX 1800mm x 600mm x 1000mm Assembly	Detail Rev.	
Part Number Numéro Pièce	Rev. 0	1 2

SEE BILL OF MATERIAL ON LAST PAGE

**6500MXK180610**

This drawing is confidential and must not be reproduced or used without the consent of EXM

Ce dessin est confidentiel et ne doit pas être reproduit ou utilisé sans le consentement de EXM

No.	Revisions	Date	By/Par

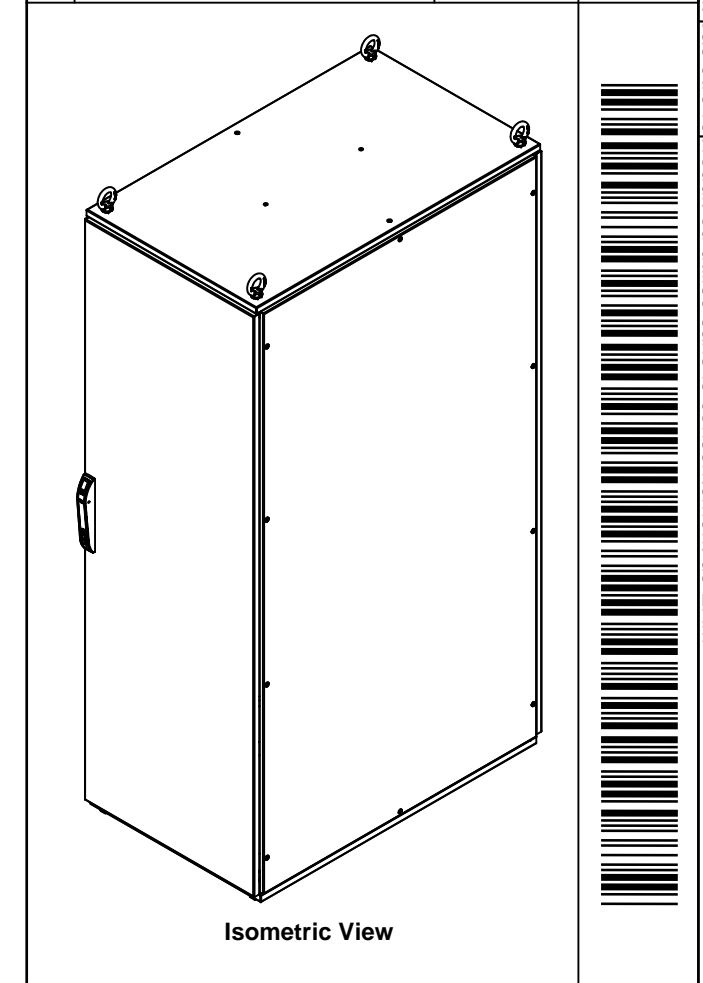

Tél: (450) 979-4373 Fax: (450) 979-4626 <a href="http://www.exmweb.com">www.exmweb.com</a>		Flatness Aplatissement
		Max 3.0mm
Projection		Date
Customer Client		Date 12/02/2015
Drawn By Dessiné Par BoxCad: Annie		Date
Material Matière		See Part List
Color Couleur	See Part List	Finish Fini See Part List
Description 6500MX 1800mm x 600mm x 1000mm Assembly		Detail Rev.
Part Number Numéro Pièce <b>6500MXK180610</b>		Rev. 2 <b>0</b>

Qty	Part Number	Rev	Description
1	6500MXK180610BIP	0	6500 MXM 1800mm x 600mm Back Inner Panel
1	6500MXK180610R	0	6500 MXC 1800mm x 1000mm Right
1	6500MXK180610L	0	6500 MXC 1800mm x 1000mm Left
1	6500MXK180610F	0	6500 MXD 1800mm x 600mm Front
1	6500MXK180610B	0	6500 MXR 1800mm x 600mm Back
1	6500MXK180610BT	0	6500 MXB 600mm x 1000mm Bottom
1	6500MXK180610T	0	6500 MXT 600mm x 1000mm Top
1	6500MXK180610FR	0	6500 MX 1800mm x 600mm x 1000mm Frame
Parts List			

This drawing is confidential and must not be reproduced or used without the consent of EXM

Ce dessin est confidentiel et ne doit pas être reproduit ou utilisé sans le consentement de EXM

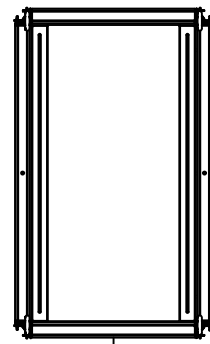

TOP

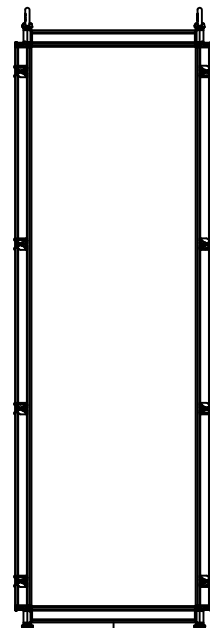

BACK

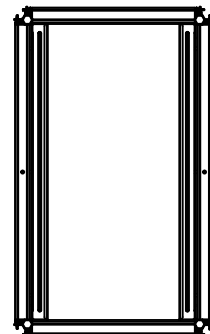

BOTTOM

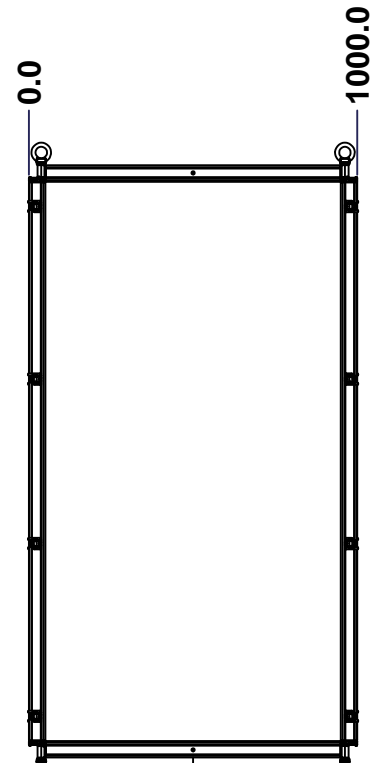

LEFT

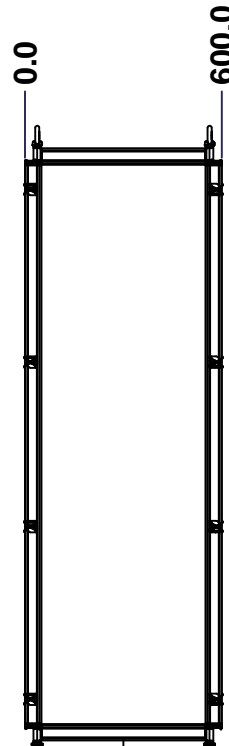

FRONT

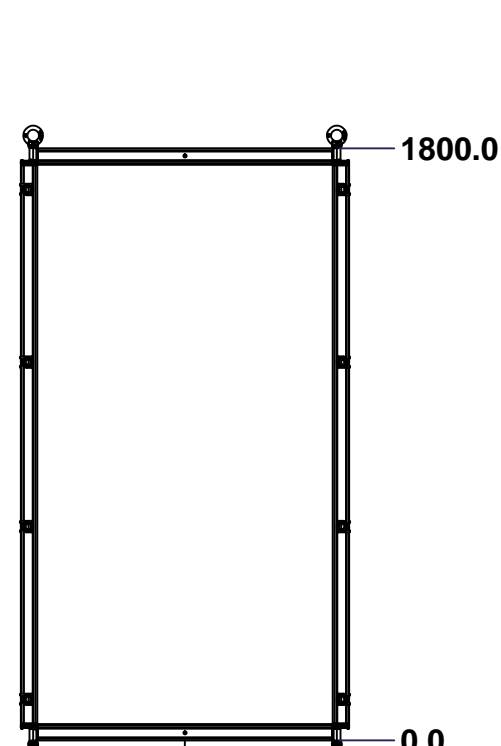

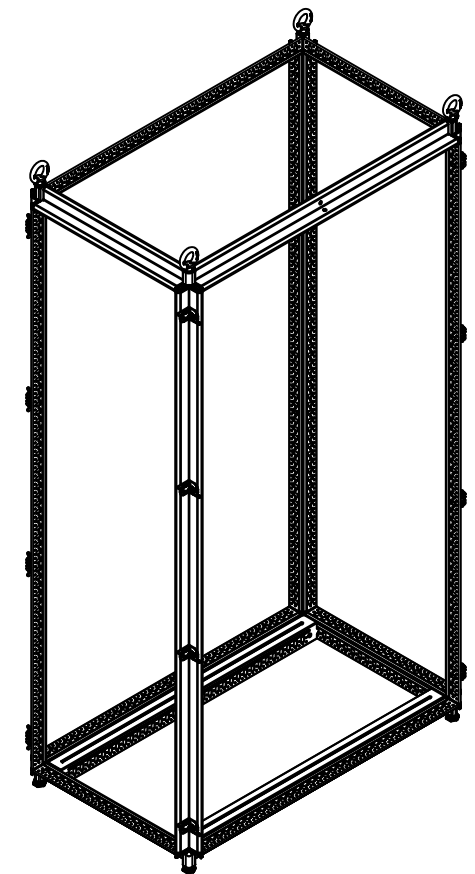

RIGHT



Isometric View

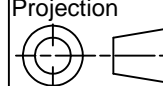

No.	Revisions	Date	By/Par

 Tél: (450) 979-4373 Fax: (450) 979-4626 <a href="http://www.exmweb.com">www.exmweb.com</a>		Flatness Aplatissement  Max 3.0mm
Customer Client		Projection 
Drawn By Dessiné Par BoxCad: Annie		Date 12/02/2015
Material Matière 16 Ga Electro-Galvanized (1.4mm)		
Color Couleur Iron Grey RAL7011	Finish Fini Rough Textured	
Description 6500 MX 1800mm x 600mm x 1000mm Frame		Detail Rev.
Part Number Numéro Pièce <b>6500MXK180610FR</b>		Rev. 1 0 2

SEE BILL OF MATERIAL ON LAST PAGE

This drawing is confidential and must not be reproduced or used without the consent of EXM

Ce dessin est confidentiel et ne doit pas être reproduit ou utilisé sans le consentement de EXM

No.	Revisions	Date	By/Par

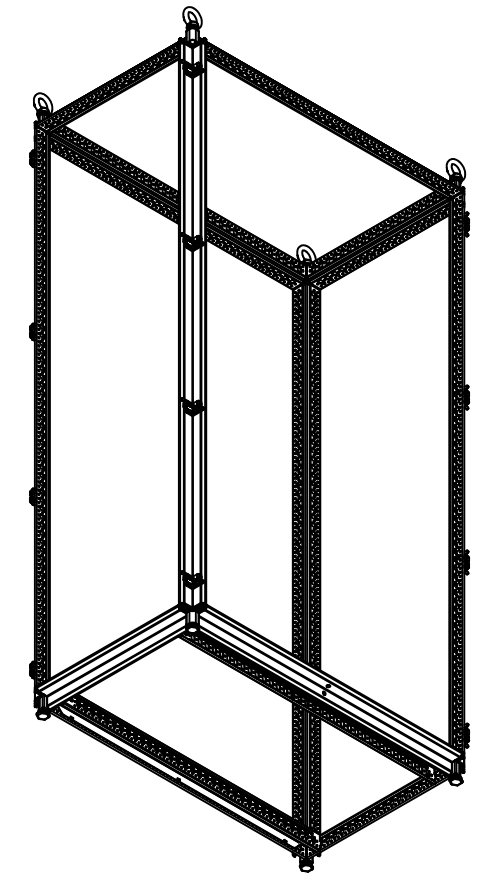

Isometric View



Qty	Part Number	Rev	Description
1	STK-P-03810R	0	Powder Paint (Iron Grey / Rough Textured)
1	STK-Q-49071	3	6500 MXM Inner Panel Slider 1000mm
1	STK-Q-49071-L	3	6500 MXM Inner Panel Slider 1000mm
4	STK-Q-49500	3	M12 Eye Bolt (0.34T)
4	STK-Q-61110	0	M12 Feet Leveler
8	STK-Q-00610	1	M18 x 30.5mm Bolt - Cover
4	STK-Q-47251-18	3	6500 MX 1800mm Vertical Frame Post Part
4	STK-Q-47250-06	3	6500 MX 600mm Horizontal Frame Post Part
4	STK-Q-47250-10	3	6500 MX 1000mm Horizontal Frame Post Part
8	STK-Q-49445	2	6500 MX - Frame Corner Bracket Casting
16	STK-K-11001	2	3 Way Fixed Bracket Kit
Parts List			

		Tél: (450) 979-4373 Fax: (450) 979-4626 <a href="http://www.exmweb.com">www.exmweb.com</a>		Flatness Aplatissement Max 3.0mm Projection 	
Customer Client		Date		Date 12/02/2015	
Drawn By Dessiné Par		BoxCad: Annie		Date	
Material Matière		16 Ga Electro-Galvanized (1.4mm)			
Color Couleur		Iron Grey RAL7011		Finish Fini Rough Textured	
Description 6500 MX 1800mm x 600mm x 1000mm Frame				Detail Rev.	
Part Number Numéro Pièce <b>6500MXK180610FR</b>				Rev. 2	
				0 2	

This drawing is confidential and must not be reproduced or used without the consent of EXM

Ce dessin est confidentiel et ne doit pas être reproduit ou utilisé sans le consentement de EXM

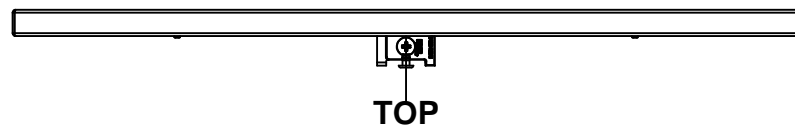

TOP

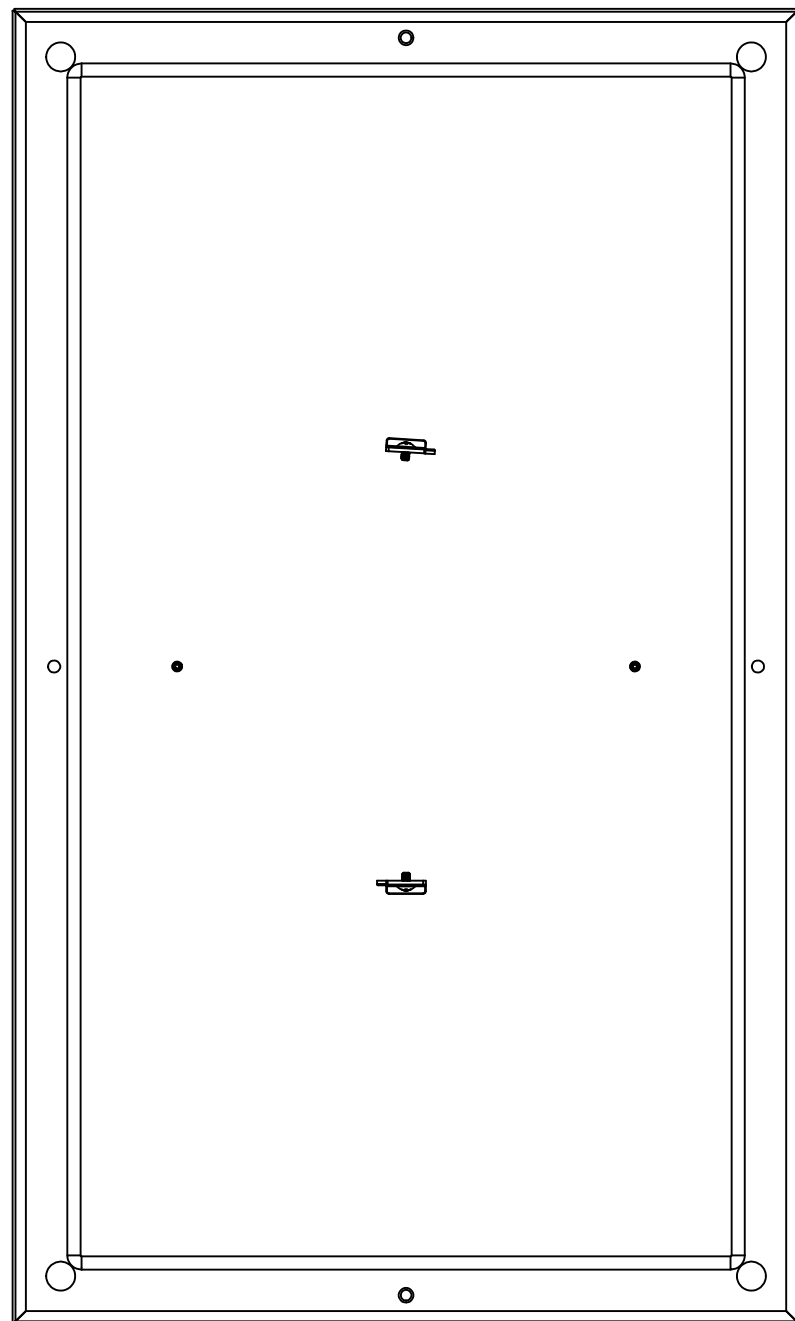

BACK

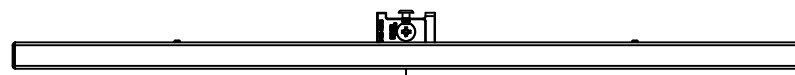

BOTTOM

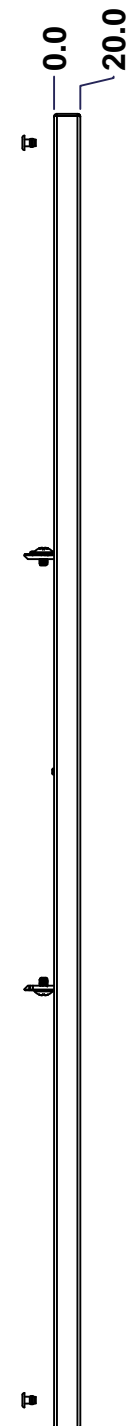

LEFT

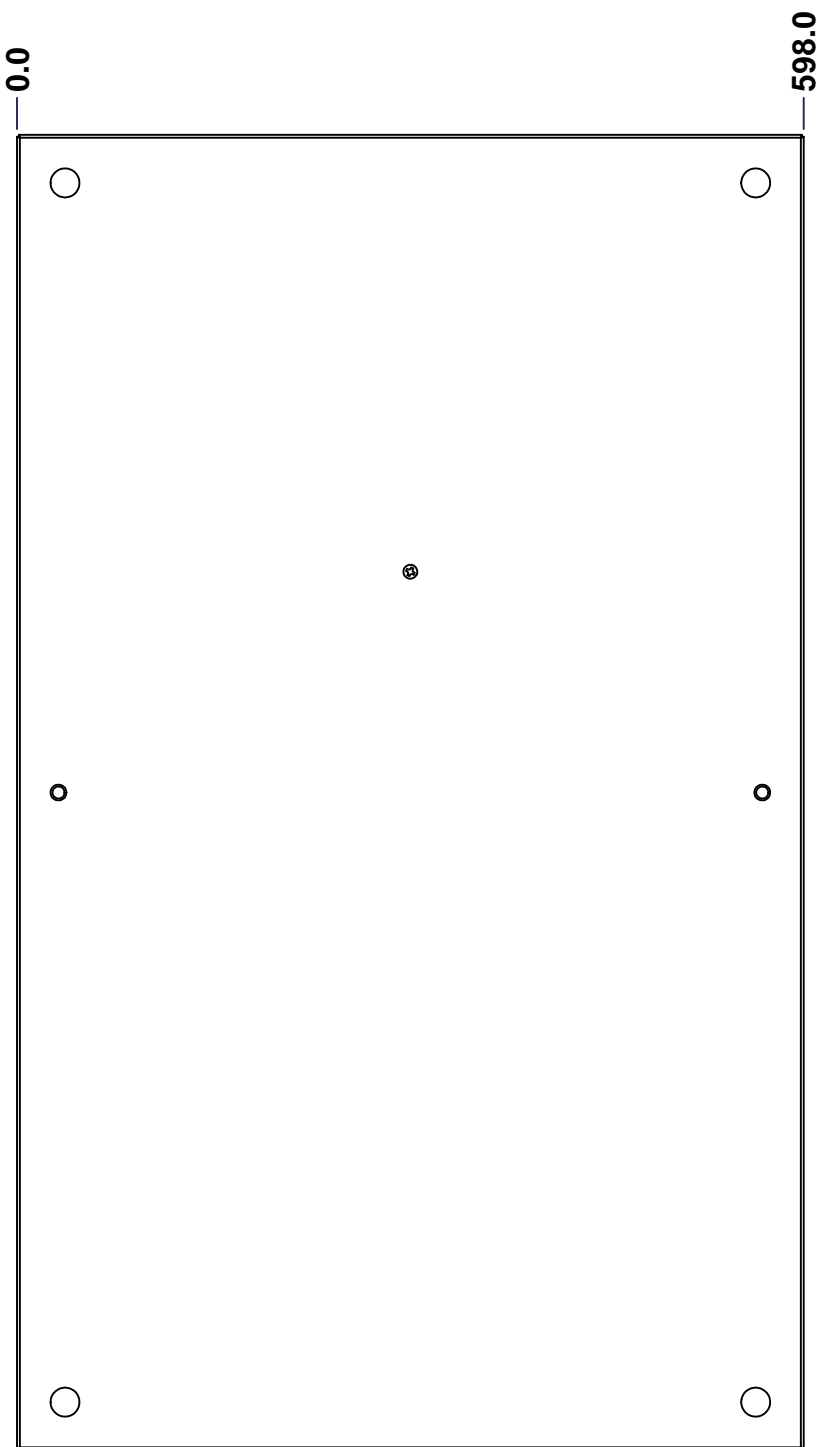

FRONT

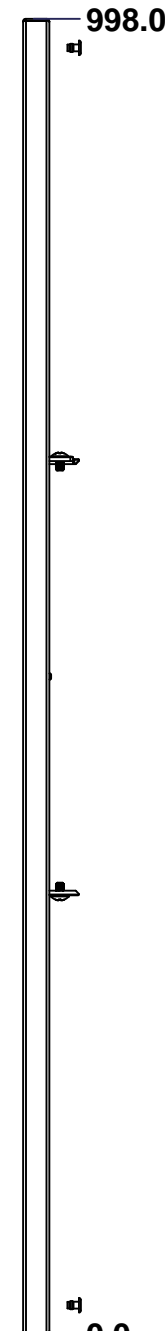

RIGHT

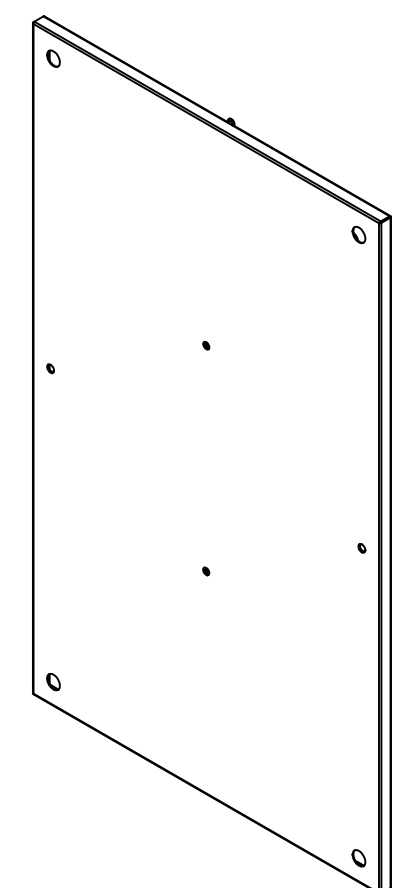

Isometric View

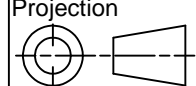

No.	Revisions	Date	By/Par

 Tél: (450) 979-4373 Fax: (450) 979-4626 <a href="http://www.exmweb.com">www.exmweb.com</a>		Flatness Aplatissement Max 3.0mm Projection 
Customer Client	Date	
Drawn By Dessiné Par	BoxCad: Annie	Date 12/02/2015
Material Matière	16 Ga H.R.P. & O. (1.4mm)	
Color Couleur	Iron Grey RAL7011	Finish Fini Rough Textured
Description	Detail Rev.	
6500 MXT 600mm x 1000mm Top		
Part Number Numéro Pièce	Rev.	1 3
<b>6500MXK180610T</b>	<b>0</b>	

SEE BILL OF MATERIAL ON LAST PAGE

This drawing is confidential and must not be reproduced or used without the consent of EXM

Ce dessin est confidentiel et ne doit pas être reproduit ou utilisé sans le consentement de EXM

STANDARD FEATURES ARE NOT LISTED IN THIS HOLE TABLE			
HOLE TABLE - FRONT VIEW (CUSTOM FEATURE ONLY)			
CUT-OUT	XDIM	YDIM	DESCRIPTION
1	125.0	499.0	GND STUD M6 x 16mm (Inside)
2	473.0	499.0	GND STUD M6 x 16mm (Inside)

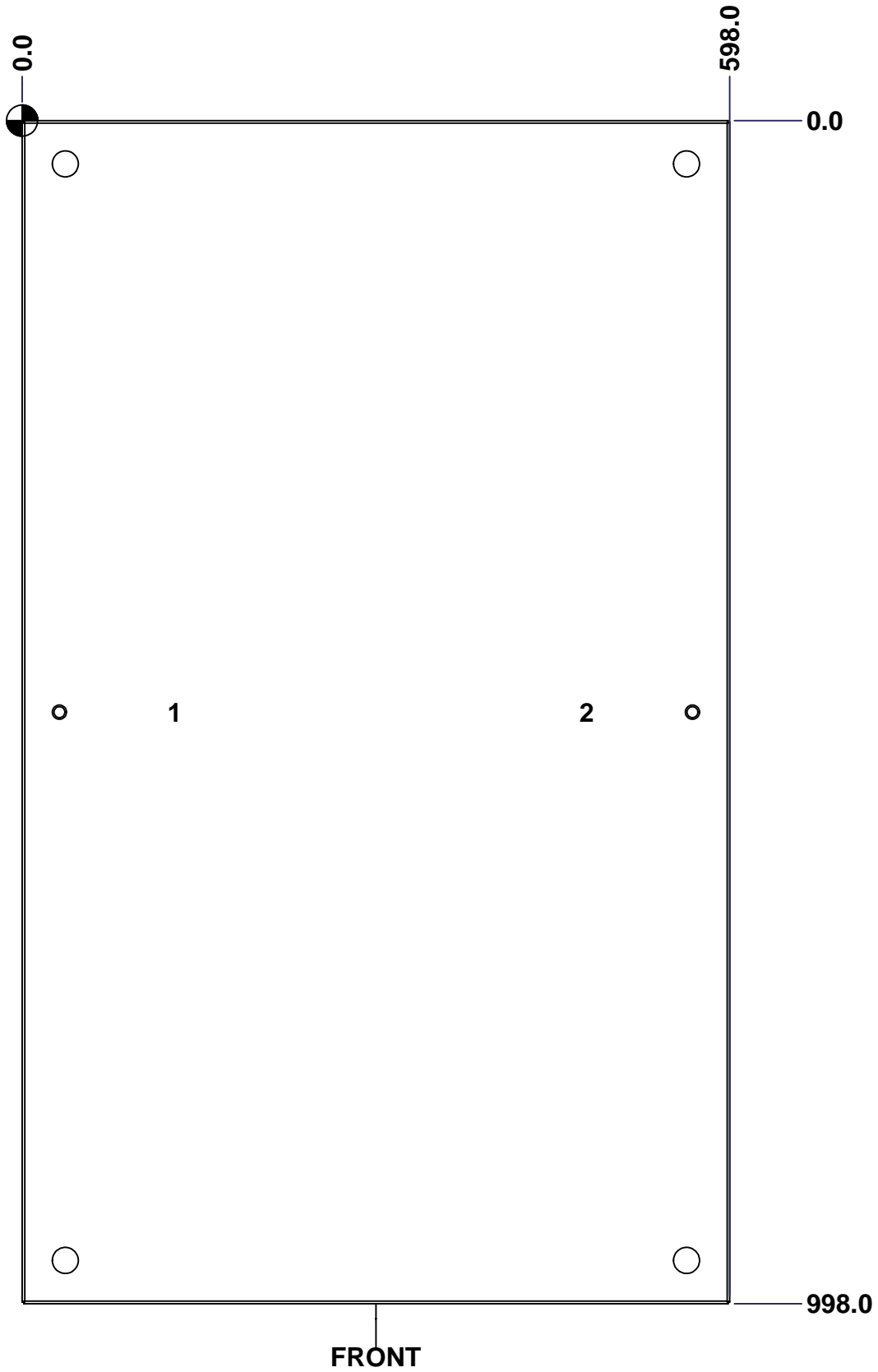



	Description	Status
	6500 MXT 600mm x 1000mm Top	(NULL)
	Part Number Numéro Pièce	Rev.
	<b>6500MXK180610T</b>	<b>0</b>
		2
		3

This drawing is confidential and must not be reproduced or used without the consent of EXM

Ce dessin est confidentiel et ne doit pas être reproduit ou utilisé sans le consentement de EXM

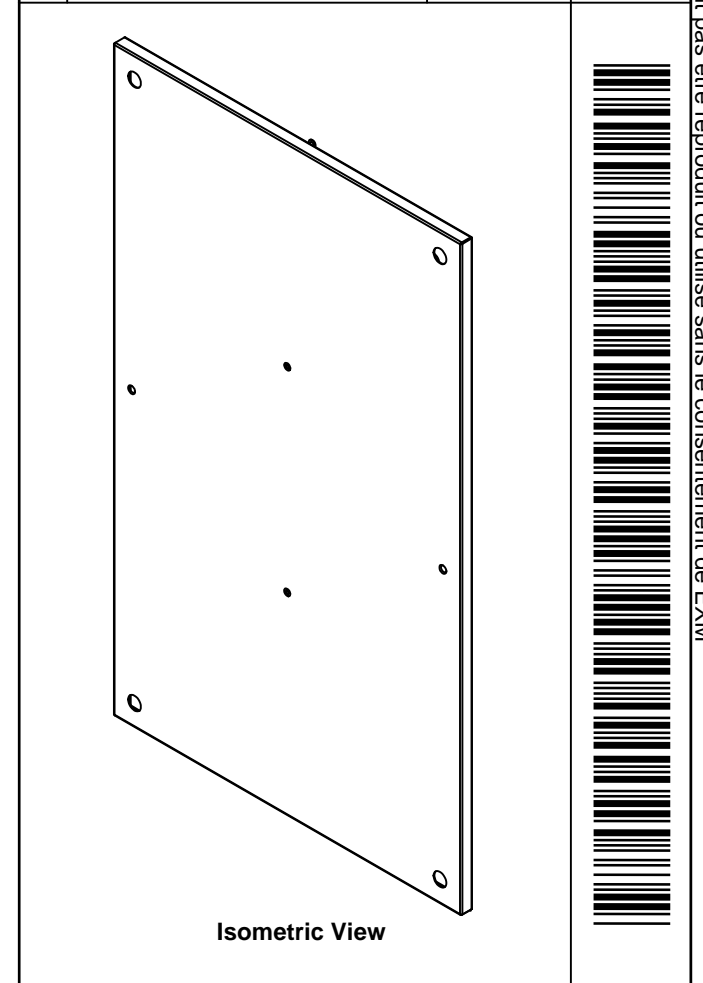
No.	Revisions	Date	By/Par

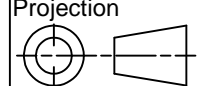

 Tél: (450) 979-4373 Fax: (450) 979-4626 <a href="http://www.exmweb.com">www.exmweb.com</a>		Flatness Aplatissement Max 3.0mm Projection 	
Customer Client		Date	
Drawn By / Dessiné Par: BoxCad: Annie		Date: 12/02/2015	
Material / Matière: 16 Ga H.R.P. & O. (1.4mm)			
Color / Couleur: Iron Grey RAL7011		Finish / Fini: Rough Textured	
Description: 6500 MXT 600mm x 1000mm Top			Detail Rev.
Part Number / Numéro Pièce: <b>6500MXK180610T</b>			Rev. 3

Qty	Part Number	Rev	Description
1	STK-P-03810R	0	Powder Paint (Iron Grey / Rough Textured)
2	STK-Q-16055	1	M6 x 18mm Stud (No Paint Cap Required)
2	STK-Q-77120	1	6500MX-Frame Rubber Plug
2	STK-Q-03072	2	M6 x 17mm Phillips Flat Head Screw
1	6500MXK180610TG	0	6500 MXT 600mm x 1000mm Top Gasket
1	6500MXK180610T-P	0	6500 MXT 600mm x 1000mm Top Part
2	STK-K-11010	3	Partial Fixed Bracket Kit
Parts List			

This drawing is confidential and must not be reproduced or used without the consent of EXM

Ce dessin est confidentiel et ne doit pas être reproduit ou utilisé sans le consentement de EXM

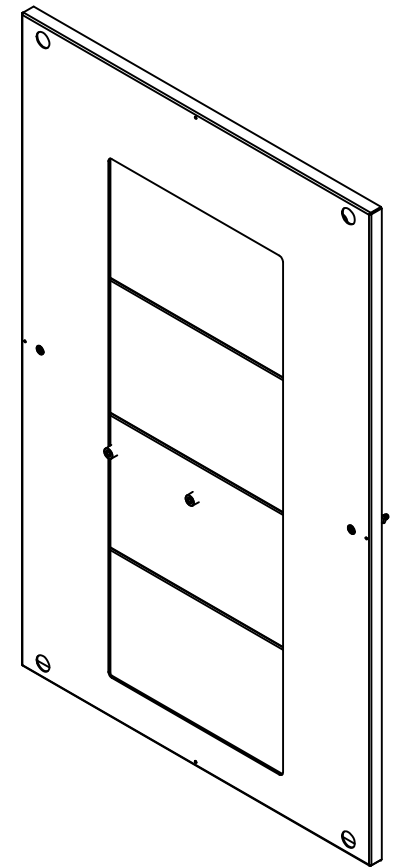
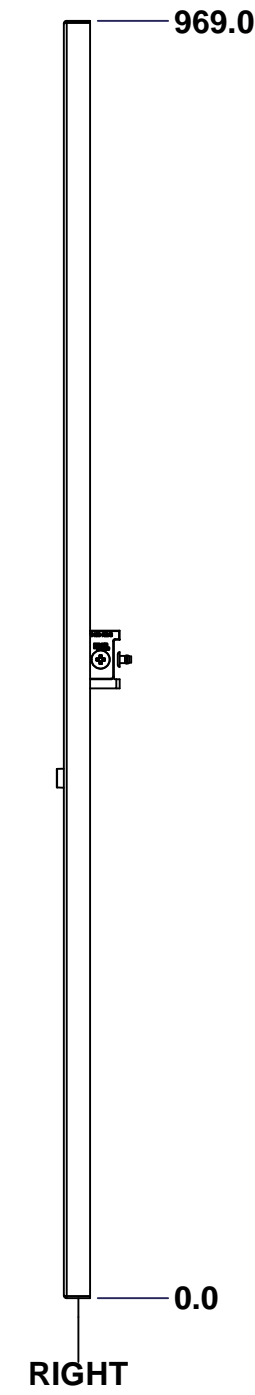
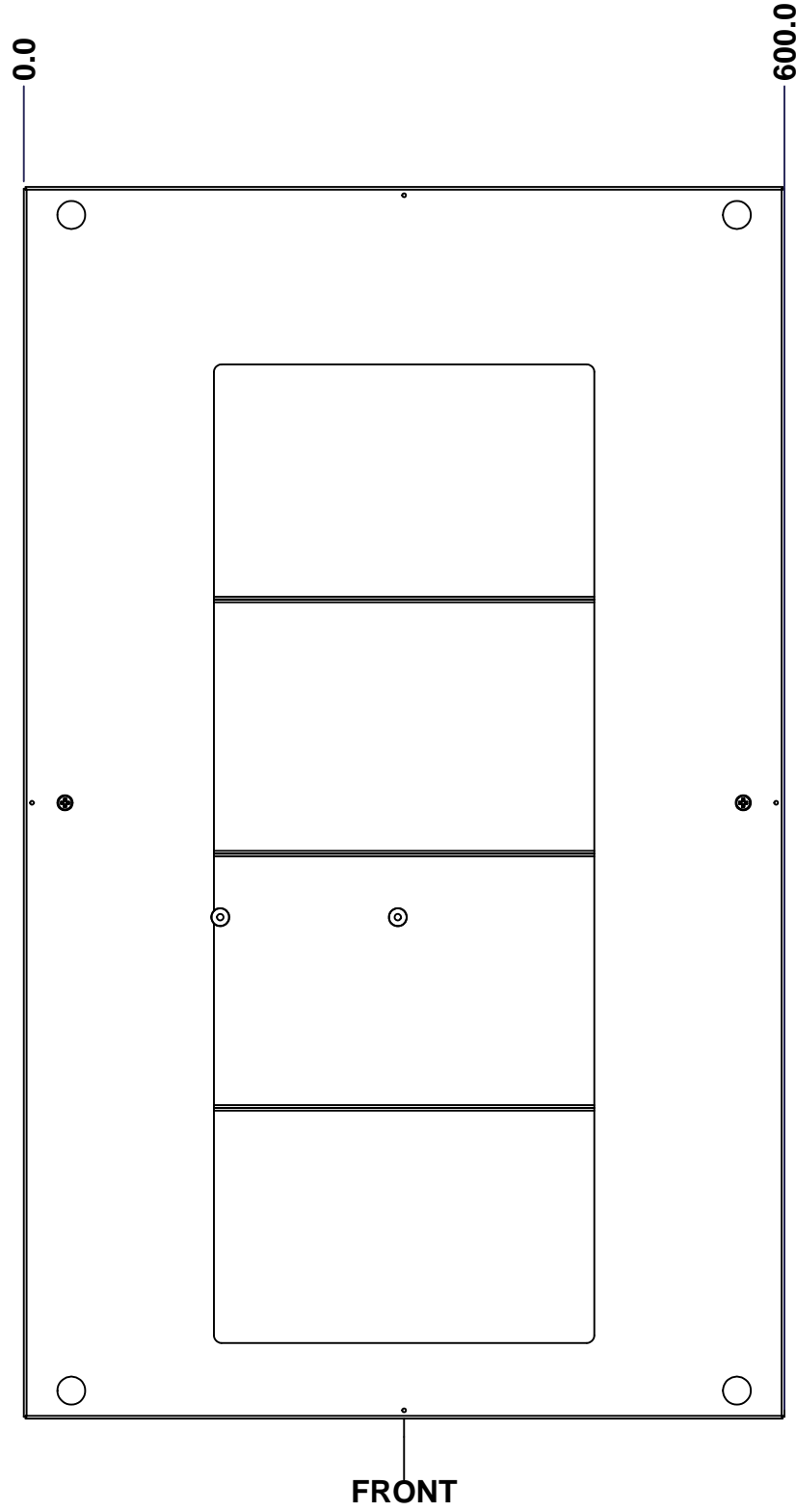
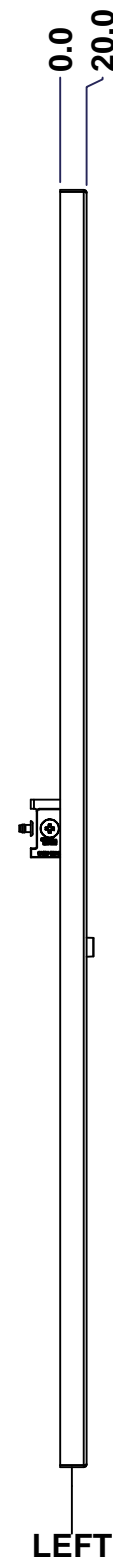
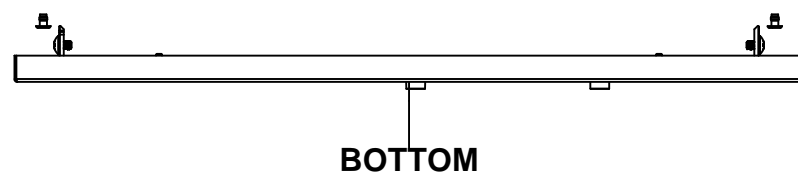
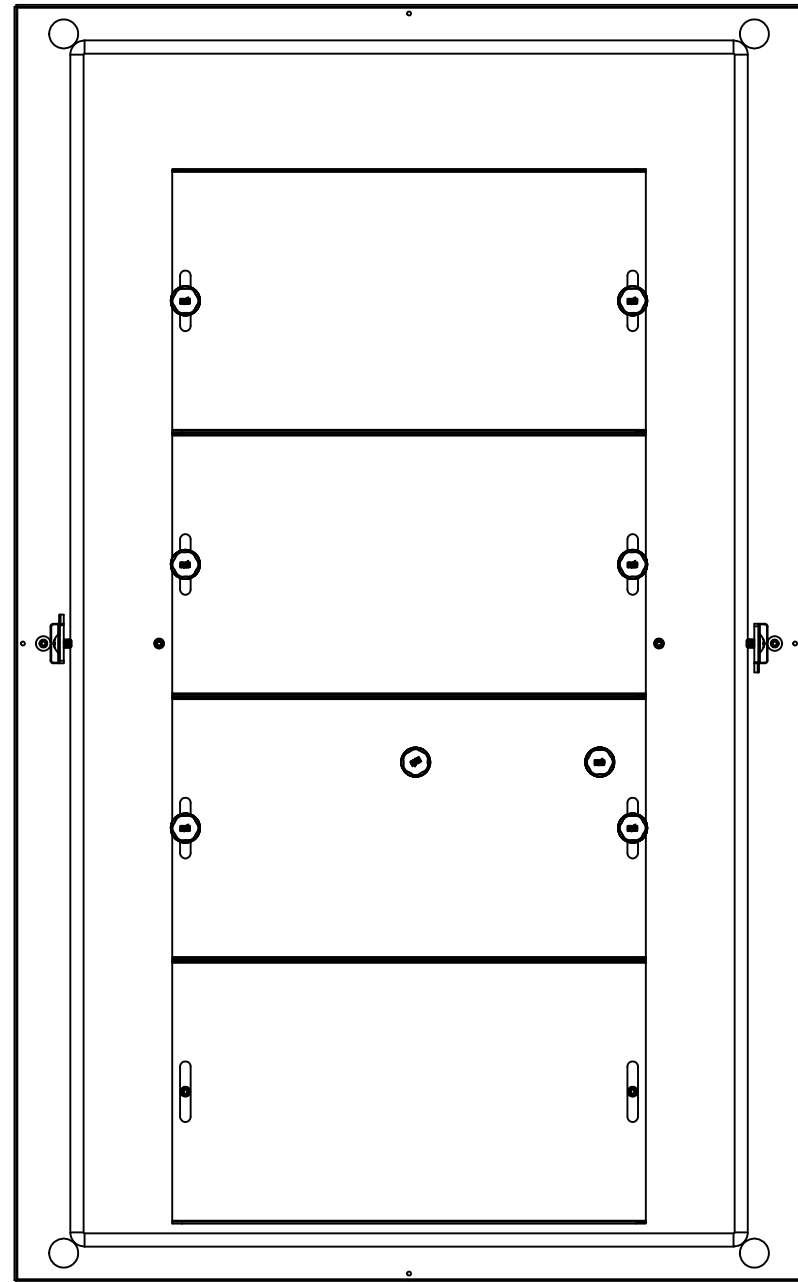
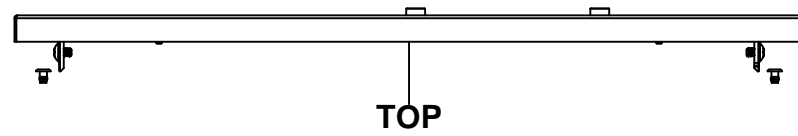

No.	Revisions	Date	By/Par

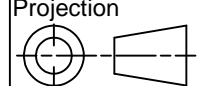
 Tél: (450) 979-4373 Fax: (450) 979-4626 <a href="http://www.exmweb.com">www.exmweb.com</a>		Flatness Aplatissement	
		Max 3.0mm	
Customer Client		Date	
Drawn By Dessiné Par BoxCad: Annie		Date 12/02/2015	
Material Matière 16 Ga H.R.P. & O. (1.4mm)		Projection	
Color Couleur Iron Grey RAL7011		 Finish Fini Rough Textured	
Description 6500 MXB 600mm x 1000mm Bottom		Detail Rev.	
Part Number Numéro Pièce <b>6500MXK180610BT</b>		Rev. <b>0</b>	1 3

**SEE BILL OF MATERIAL ON LAST PAGE**



This drawing is confidential and must not be reproduced or used without the consent of EXM

Ce dessin est confidentiel et ne doit pas être reproduit ou utilisé sans le consentement de EXM

**STANDARD FEATURES ARE NOT LISTED IN THIS HOLE TABLE**

**HOLE TABLE - FRONT VIEW (CUSTOM FEATURE ONLY)**

CUT-OUT	XDIM	YDIM	DESCRIPTION
1	110.0	484.5	GND STUD M6 x 16mm (Inside)
2	490.0	484.5	GND STUD M6 x 16mm (Inside)
3	130.0	744.5	GP STUD M6 x 10mm (Inside)
4	470.0	744.5	GP STUD M6 x 10mm (Inside)
5	130.0	544.5	GP STUD M6 x 10mm (Inside)
6	470.0	544.5	GP STUD M6 x 10mm (Inside)
7	130.0	344.5	GP STUD M6 x 10mm (Inside)
8	470.0	344.5	GP STUD M6 x 10mm (Inside)
9	130.0	144.5	GP STUD M6 x 10mm (Inside)
10	470.0	144.5	GP STUD M6 x 10mm (Inside)

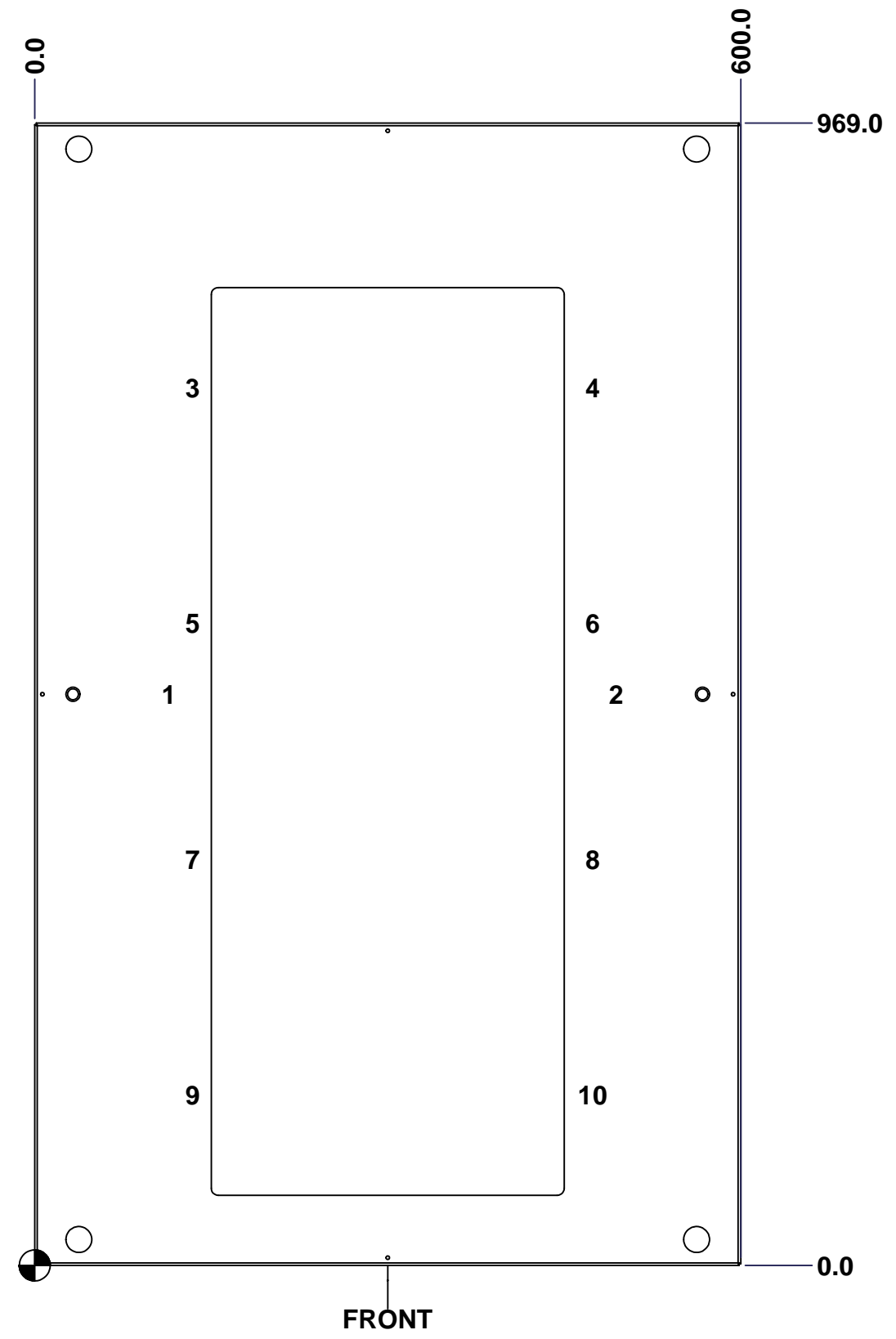

	Description	Status
	6500 MXB 600mm x 1000mm Bottom	(NULL)
	Part Number Numéro Pièce	Rev.
	<b>6500MXK180610BT</b>	<b>0</b>
		2
		3

This drawing is confidential and must not be reproduced or used without the consent of EXM

Ce dessin est confidentiel et ne doit pas être reproduit ou utilisé sans le consentement de EXM

No.	Revisions	Date	By/Par

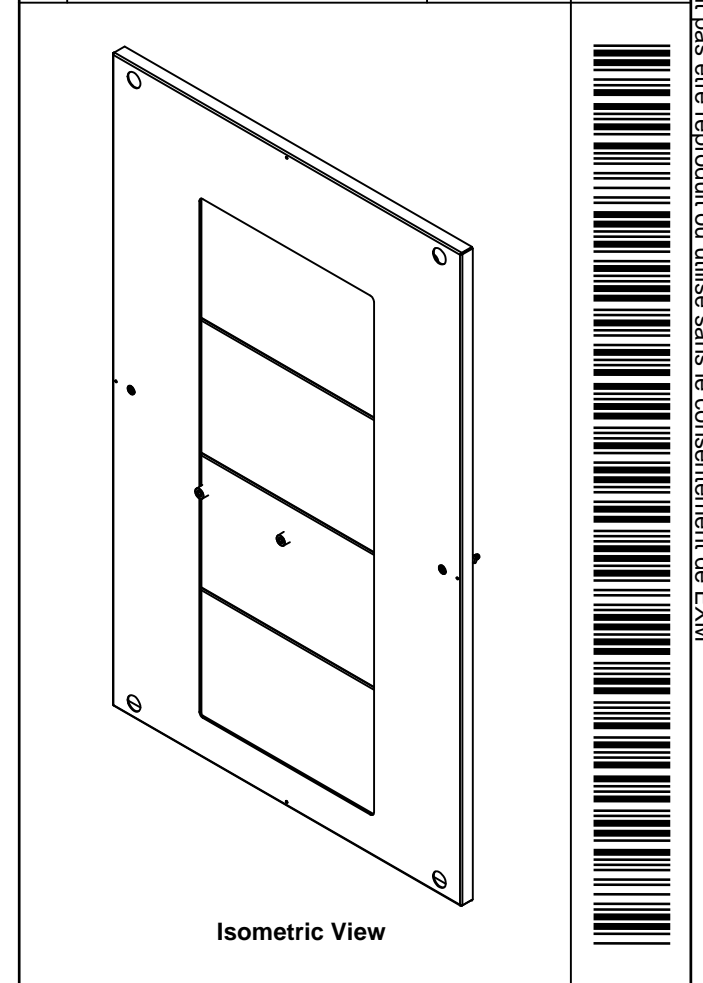

Qty	Part Number	Rev	Description
1	STK-P-03810R	0	Powder Paint (Iron Grey / Rough Textured)
2	STK-Q-06001	0	Mtrx - Gland Plate M6 Plastic Thumb Nut
2	STK-Q-16055	1	M6 x 18mm Stud (No Paint Cap Required)
2	STK-Q-77120	1	6500MX-Frame Rubber Plug
2	STK-Q-03072	2	M6 x 17mm Phillips Flat Head Screw
6			
4	6500MXK180610GP200-P	0	6500 MXB 600mm Gland Plate Part (200mm)
8	STK-Q-16031	0	M6 x 10mm Stud (No Paint Cap Required)
1	6500MXK180610BTGPG	0	6500 MXB 600mm x 1000mm Bottom Gland Plate Gasket
1	6500MXK180610BTG	0	6500 MXB 600mm x 1000mm Bottom Gasket
1	6500MXK180610BT-P	0	6500 MXB 600mm x 1000mm Bottom Part
2	STK-K-11010	3	Partial Fixed Bracket Kit

Parts List

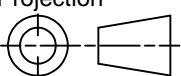
 Tél: (450) 979-4373 Fax: (450) 979-4626 <a href="http://www.exmweb.com">www.exmweb.com</a>		Flatness Aplatissement Max 3.0mm Projection 
Customer Client	Date	Date
Drawn By Dessiné Par	BoxCad: Annie	Date 12/02/2015
Material Matière	16 Ga H.R.P. & O. (1.4mm)	
Color Couleur	Iron Grey RAL7011	Finish Fini Rough Textured
Description	Detail Rev.	
6500 MXB 600mm x 1000mm Bottom		
Part Number Numéro Pièce	Rev.	3
<b>6500MXK180610BT</b>	<b>0</b>	<b>3</b>

This drawing is confidential and must not be reproduced or used without the consent of EXM

Ce dessin est confidentiel et ne doit pas être reproduit ou utilisé sans le consentement de EXM

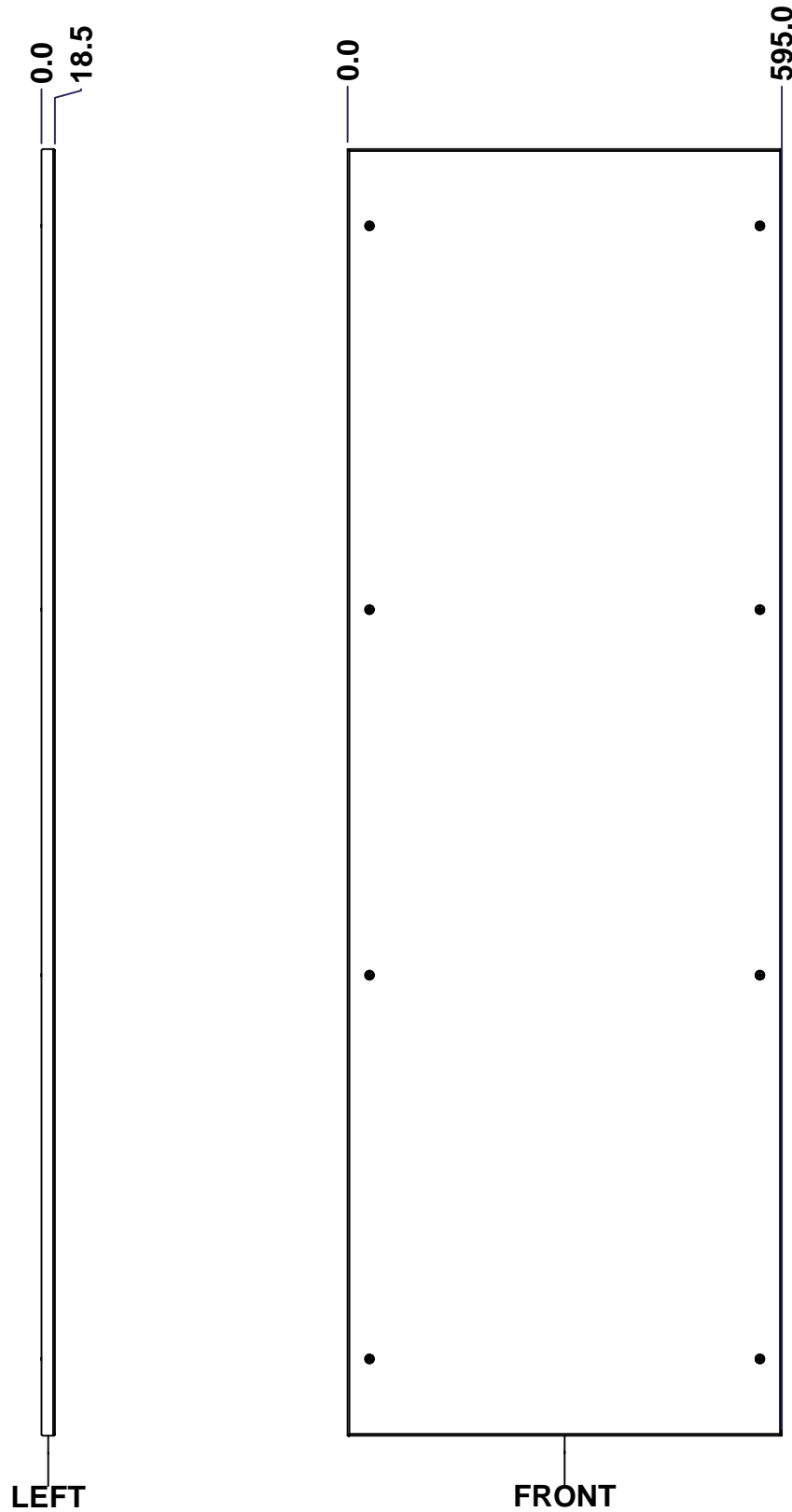
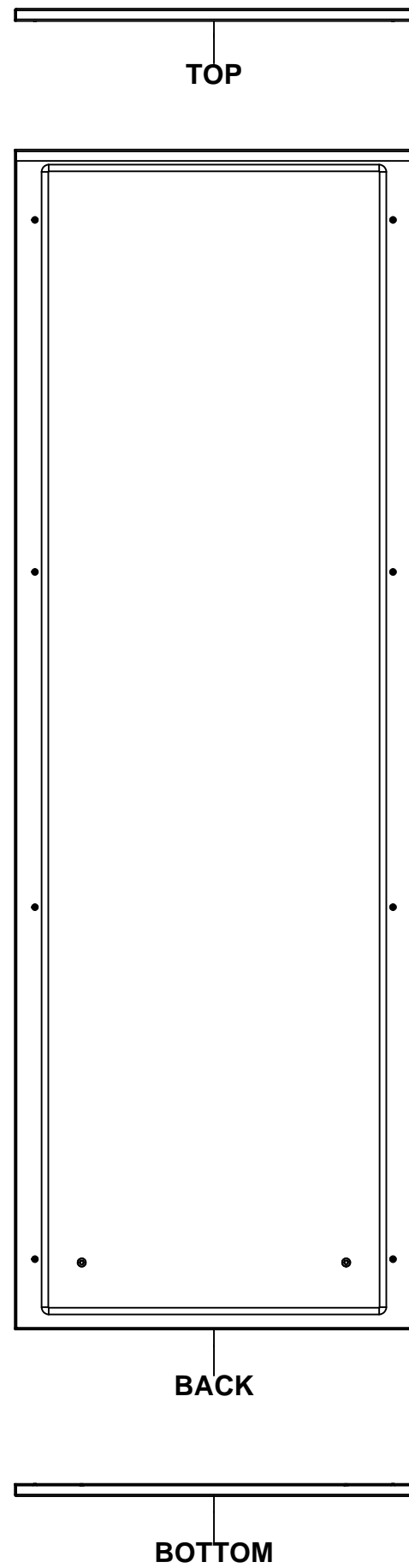

No.	Revisions	Date	By/Par

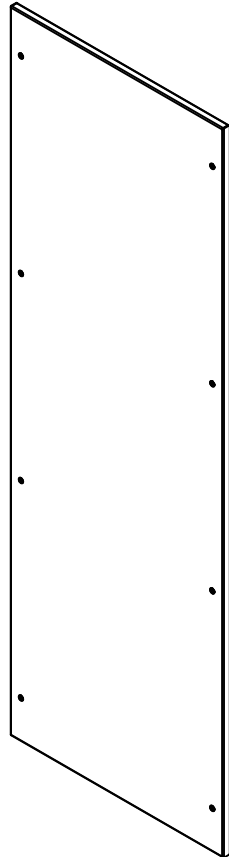

Isometric View

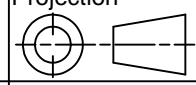

 Tél: (450) 979-4373 Fax: (450) 979-4626 <a href="http://www.exmweb.com">www.exmweb.com</a>		Flatness Aplatissement			
		Max 3.0mm			
Customer Client		Projection			
Date					
Drawn By Dessiné Par BoxCad: Annie		Date 12/02/2015			
Material Matière 14 Ga H.R.P. & O. (1.7mm)					
Color Couleur Light Grey RAL7035	Finish Fini Rough Textured				
Description 6500 MXR 1800mm x 600mm Back		Detail Rev.			
Part Number Numéro Pièce <b>6500MXK180610B</b>		Rev. <b>0</b>	<table border="1" style="width: 100%;"> <tr> <td style="text-align: center;">1</td> </tr> <tr> <td style="text-align: center;">3</td> </tr> </table>	1	3
1					
3					

SEE BILL OF MATERIAL ON LAST PAGE

This drawing is confidential and must not be reproduced or used without the consent of EXM

Ce dessin est confidentiel et ne doit pas être reproduit ou utilisé sans le consentement de EXM

STANDARD FEATURES ARE NOT LISTED IN THIS HOLE TABLE			
HOLE TABLE - FRONT VIEW (CUSTOM FEATURE ONLY)			
CUT-OUT	XDIM	YDIM	DESCRIPTION
1	100.0	100.0	GND STUD M6 x 16mm (Inside)
2	495.0	100.0	GND STUD M6 x 16mm (Inside)

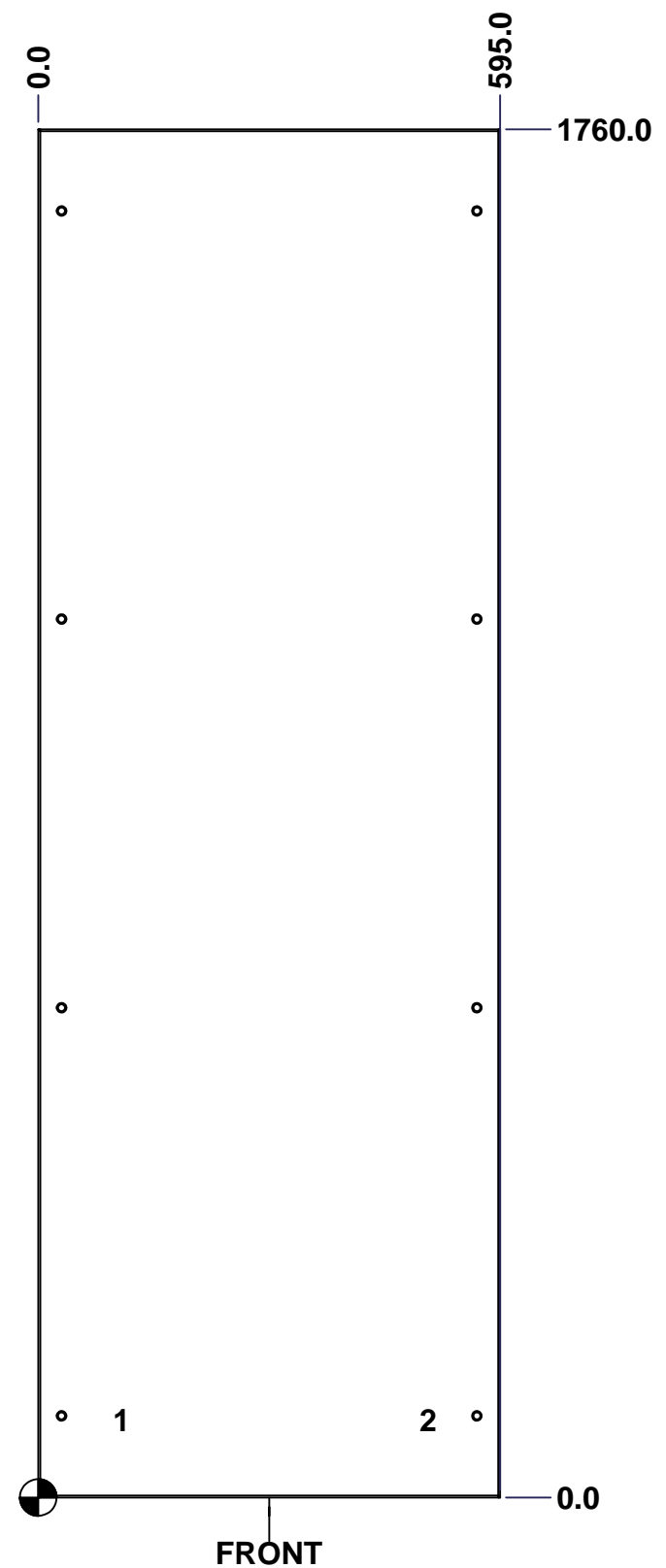



	Description	Status
	6500 MXR 1800mm x 600mm Back	(NULL)
	Part Number Numéro Pièce	Rev.
	<b>6500MXK180610B</b>	<b>0</b>
		2
		3

This drawing is confidential and must not be reproduced or used without the consent of EXM

Ce dessin est confidentiel et ne doit pas être reproduit ou utilisé sans le consentement de EXM

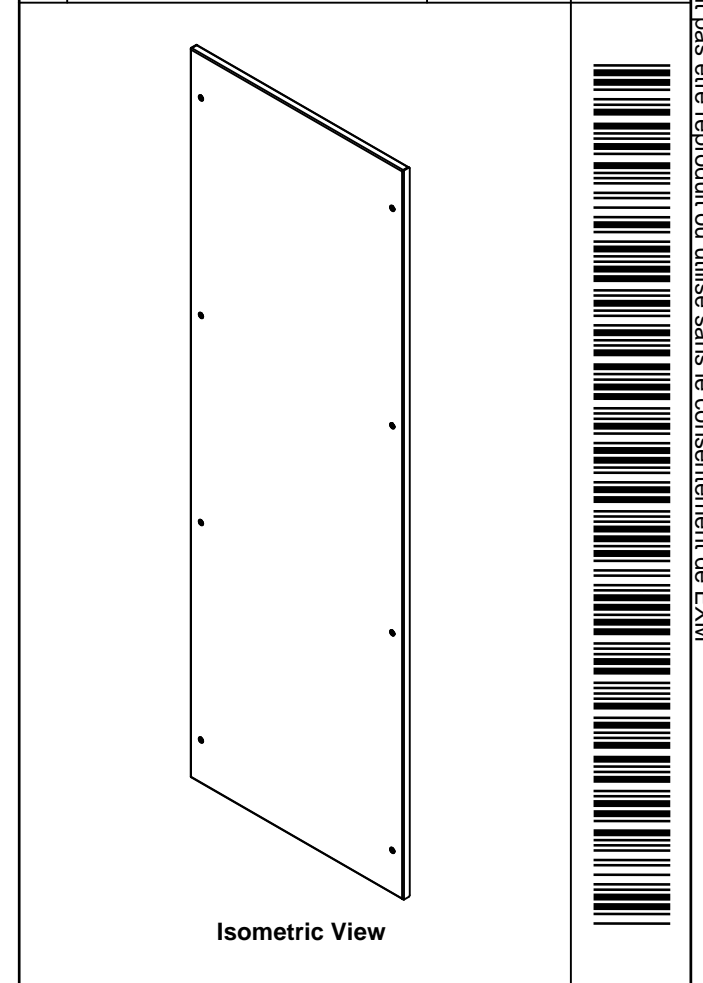
No.	Revisions	Date	By/Par

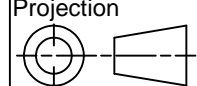

 Tél: (450) 979-4373 Fax: (450) 979-4626 <a href="http://www.exmweb.com">www.exmweb.com</a>		Flatness Aplatissement Max 3.0mm Projection 	
Customer Client		Date	
Drawn By / Dessiné Par: BoxCad: Annie		Date: 12/02/2015	
Material / Matière: 14 Ga H.R.P. & O. (1.7mm)			
Color / Couleur: Light Grey RAL7035		Finish / Fini: Rough Textured	
Description: 6500 MXR 1800mm x 600mm Back			Detail Rev.
Part Number / Numéro Pièce: <b>6500MXK180610B</b>			Rev. 3

Qty	Part Number	Rev	Description
1	STK-P-03820R	0	Powder Paint (Light Grey / Rough Textured)
8	STK-Q-03072	2	M6 x 17mm Phillips Flat Head Screw
2	STK-Q-16080	0.1.1	M6 x 16mm Ground Stud
1	6500MXK180610BG	0	6500 MXR 1800mm x 600mm Back Gasket
1	6500MXK180610B-P	0	6500 MXR 1800mm x 600mm Back Part
Parts List			

This drawing is confidential and must not be reproduced or used without the consent of EXM

Ce dessin est confidentiel et ne doit pas être reproduit ou utilisé sans le consentement de EXM



TOP

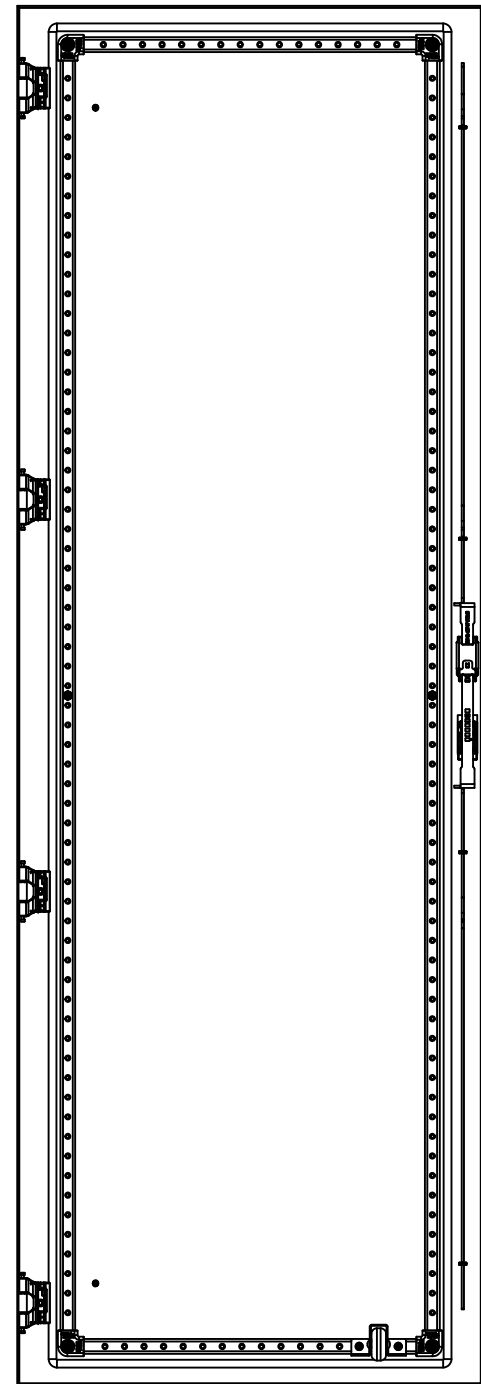

BACK



BOTTOM

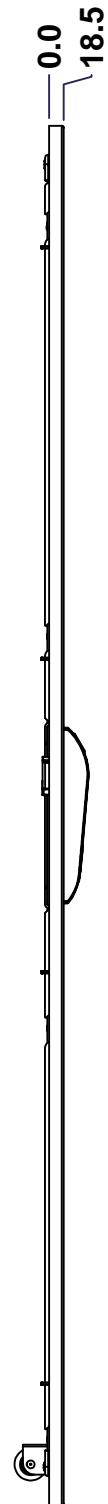

LEFT

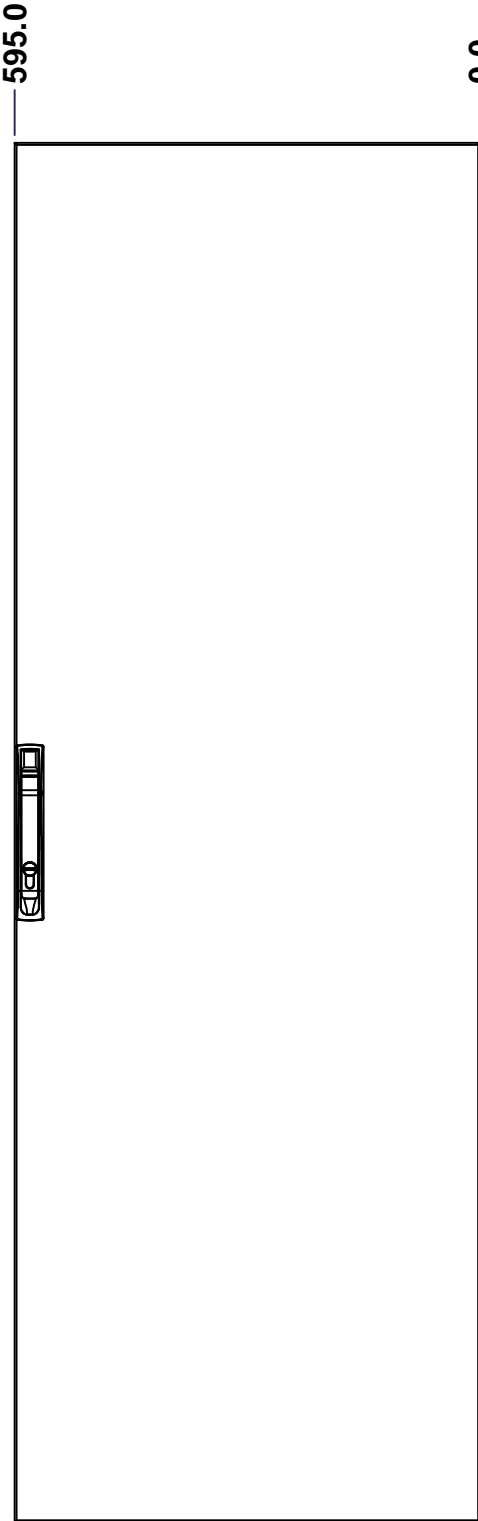

FRONT

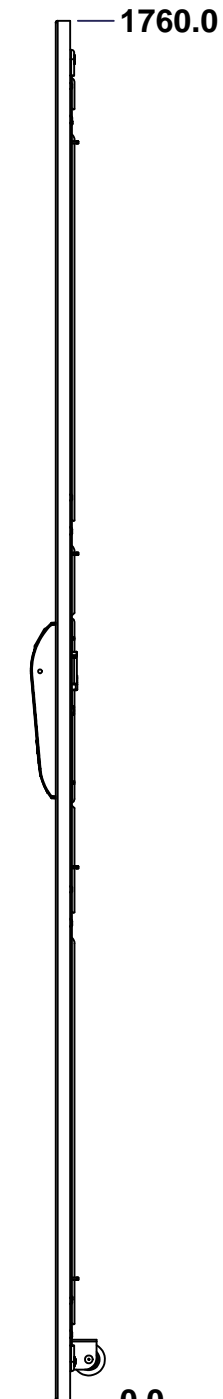

RIGHT

No.	Revisions	Date	By/Par

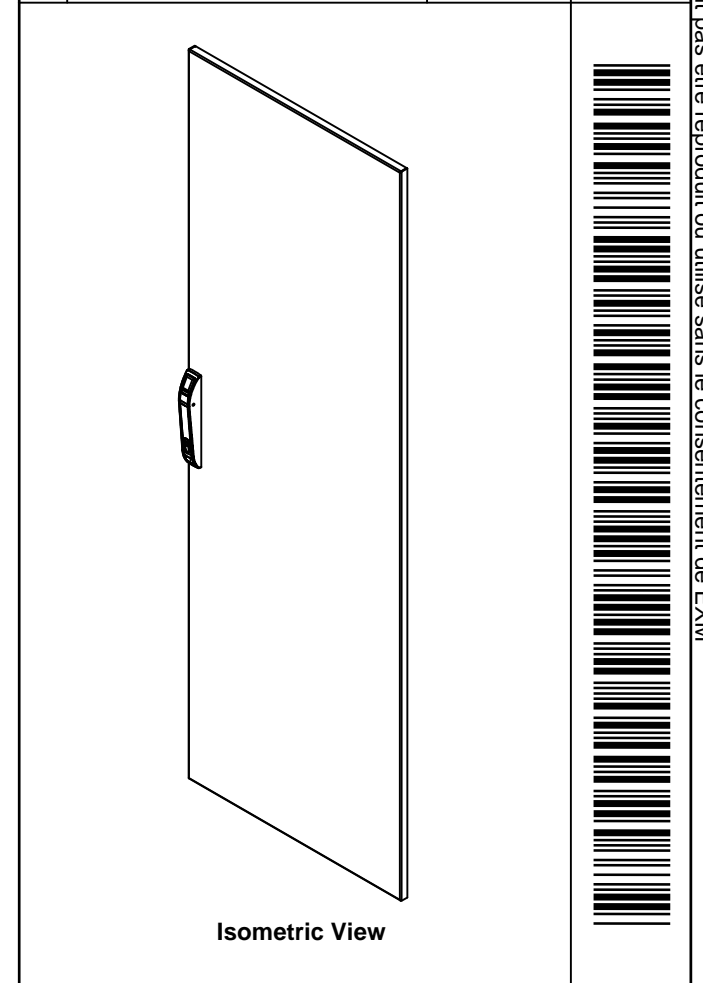

Isometric View

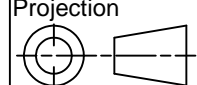
 Tél: (450) 979-4373 Fax: (450) 979-4626 <a href="http://www.exmweb.com">www.exmweb.com</a>		Flatness Aplatissement Max 3.0mm Projection 
Customer Client	Date	
Drawn By Dessiné Par	BoxCad: Annie	Date 12/02/2015
Material Matière	14 Ga H.R.P. & O. (1.7mm)	
Color Couleur	Light Grey RAL7035	Finish Fin Rough Textured
Description		Detail Rev.
6500 MXD 1800mm x 600mm Front		
Part Number Numéro Pièce	Rev. 0	1 / 3
<b>6500MXK180610F</b>		

SEE BILL OF MATERIAL ON LAST PAGE

This drawing is confidential and must not be reproduced or used without the consent of EXM

Ce dessin est confidentiel et ne doit pas être reproduit ou utilisé sans le consentement de EXM

**STANDARD FEATURES ARE NOT LISTED IN THIS HOLE TABLE**

**HOLE TABLE - FRONT VIEW (CUSTOM FEATURE ONLY)**

CUT-OUT	XDIM	YDIM	DESCRIPTION
1	100.0	130.0	GND STUD M6 x 16mm (Inside)
2	100.0	1630.0	GND STUD M6 x 16mm (Inside)
3	64.5	49.5	STIFF. STUD M6 x 18mm (Inside)
4	64.5	880.0	STIFF. STUD M6 x 18mm (Inside)
5	64.5	1710.5	STIFF. STUD M6 x 18mm (Inside)
6	530.5	49.5	STIFF. STUD M6 x 18mm (Inside)
7	530.5	880.0	STIFF. STUD M6 x 18mm (Inside)
8	530.5	1710.5	STIFF. STUD M6 x 18mm (Inside)
9	569.5	155.0	CLOSING BAR GUIDE (Inside)
10	569.5	1605.0	CLOSING BAR GUIDE (Inside)
11	569.5	680.0	CLOSING BAR GUIDE (Inside)
12	569.5	1080.0	CLOSING BAR GUIDE (Inside)

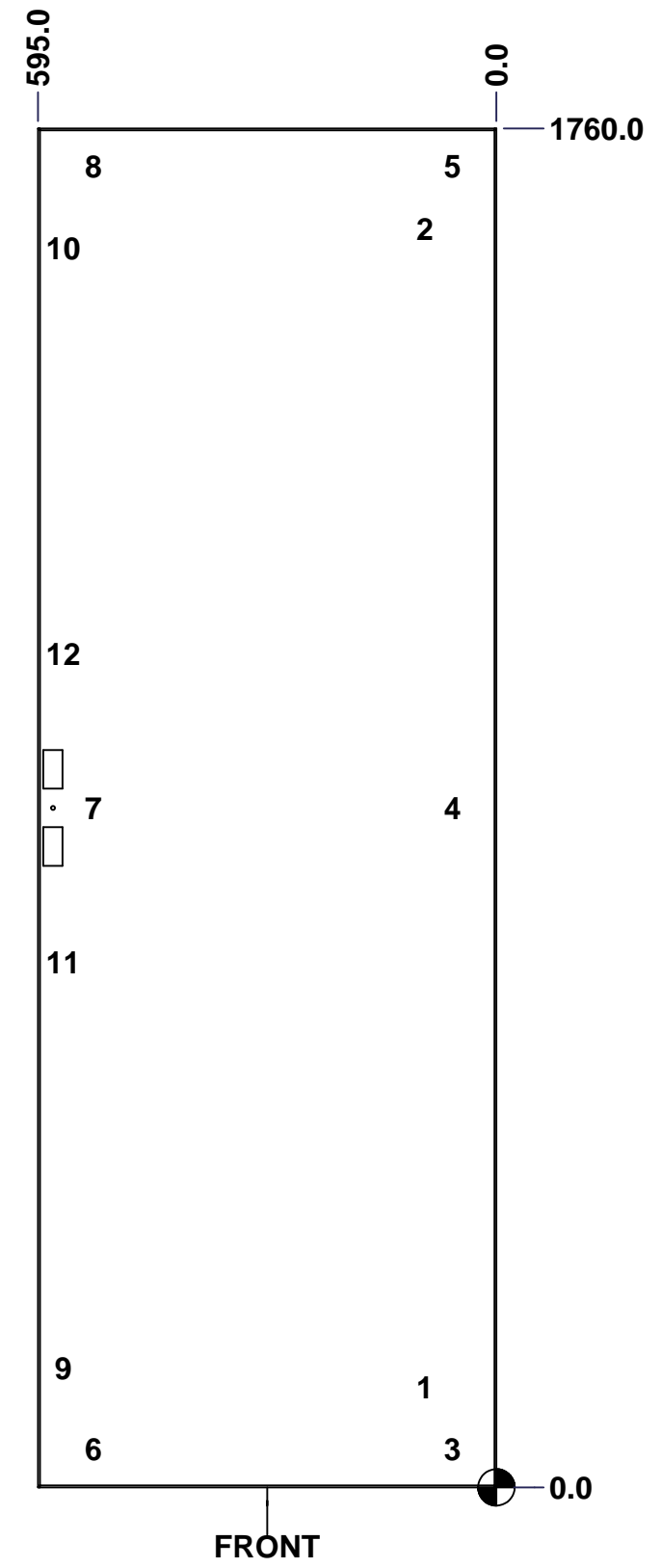

	Description	Status
	6500 MXD 1800mm x 600mm Front	(NULL)
	Part Number Numéro Pièce	Rev.
	<b>6500MXK180610F</b>	<b>0</b>
		2
		3

This drawing is confidential and must not be reproduced or used without the consent of EXM

Ce dessin est confidentiel et ne doit pas être reproduit ou utilisé sans le consentement de EXM

No.	Revisions	Date	By/Par

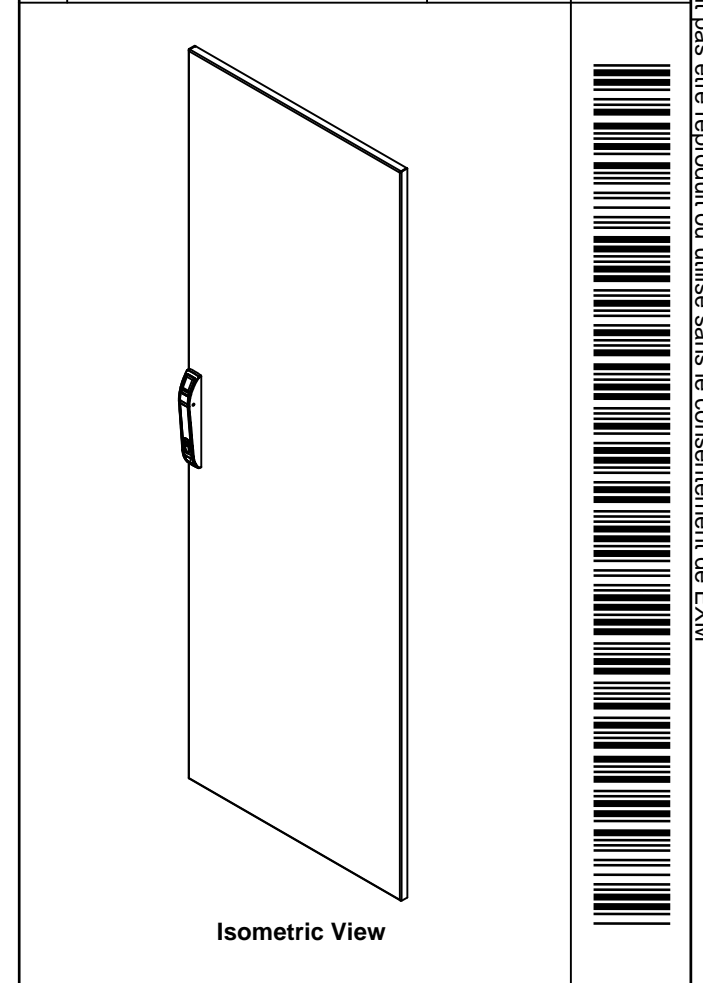

1	STK-P-03820R	0	Powder Paint (Light Grey / Rough Textured)
1	6500MXSRK	1	6500 MXRSK Door Support Roller
4	STK-Q-78022	0	Mtrx Closing Bar Slider
1	STK-Q-45746-18	1	6500 MXD - Lock Door Closing Bar
4	STK-Q-33105	4	5412 ESBU Buttable Hinge (Cover Part)
1	STK-Q-45729-18	2	6500 MXD - Lock Door Top Closing Bar
1	886PHD-S	4	Euroform Pull Handle Kit
8	STK-Q-16055	1	M6 x 18mm Stud (No Paint Cap Required)
1	6500MXK180610DS1	5	6500 MX 1800mm x 600mm Door Stiffener
1	6500MXK180610FG	0	6500 MXD 1800mm x 600mm Front Gasket
1	6500MXK180610F-P	0	6500 MXD 1800mm x 600mm Front Part
4	STK-K-06811	1	6500 MX - Hinge Assy
Qty	Part Number	Rev	Description
Parts List			

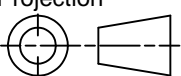
 Tél: (450) 979-4373 Fax: (450) 979-4626 <a href="http://www.exmweb.com">www.exmweb.com</a>		Flatness Aplatissement Max 3.0mm Projection 
Customer Client	Date	Date
Drawn By Dessiné Par	BoxCad: Annie	Date 12/02/2015
Material Matière	14 Ga H.R.P. & O. (1.7mm)	
Color Couleur	Light Grey RAL7035	Finish Fini
		Rough Textured
Description		Detail Rev.
6500 MXD 1800mm x 600mm Front		
Part Number Numéro Pièce	Rev.	3
<b>6500MXK180610F</b>	<b>0</b>	<b>3</b>



This drawing is confidential and must not be reproduced or used without the consent of EXM

Ce dessin est confidentiel et ne doit pas être reproduit ou utilisé sans le consentement de EXM

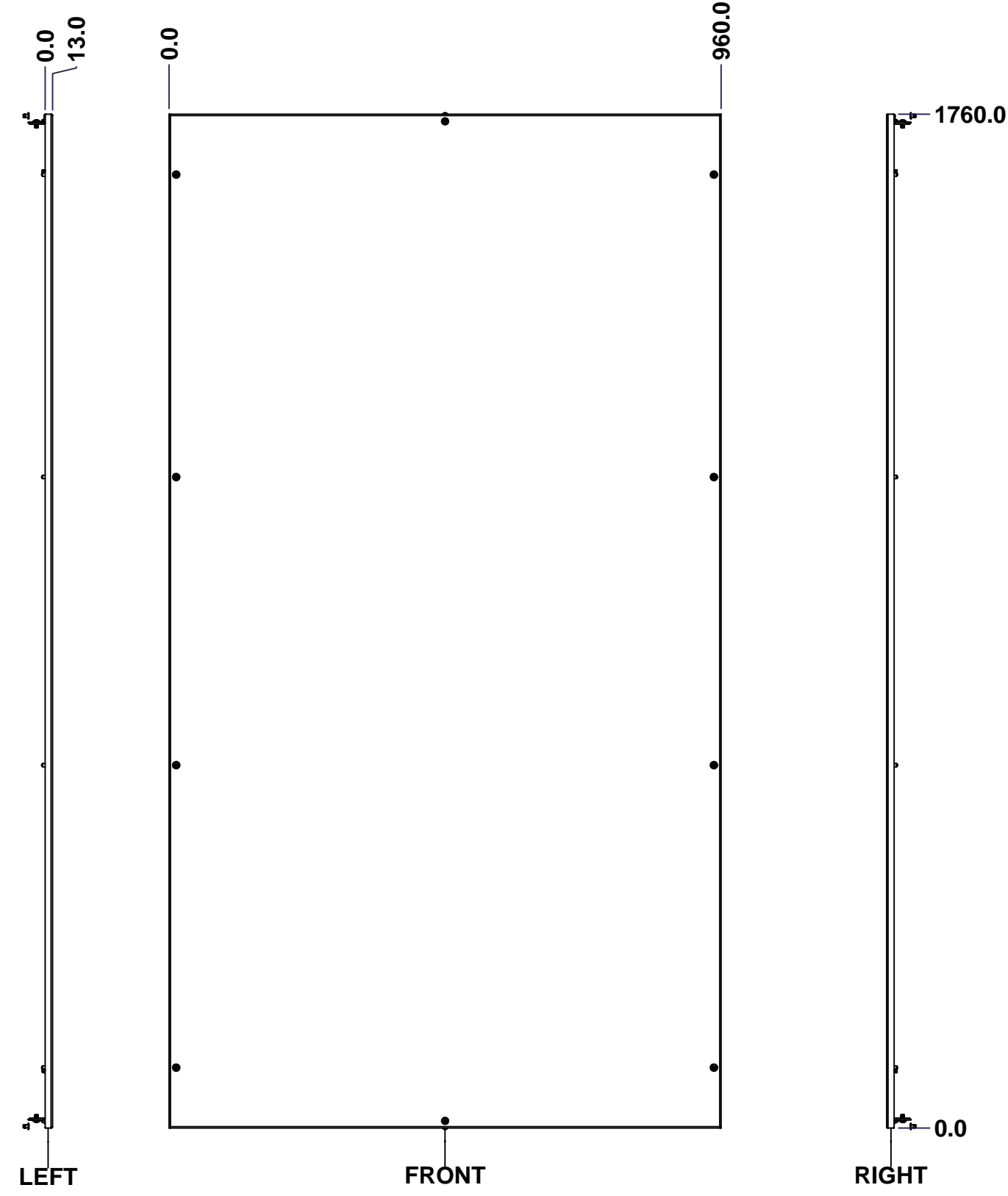
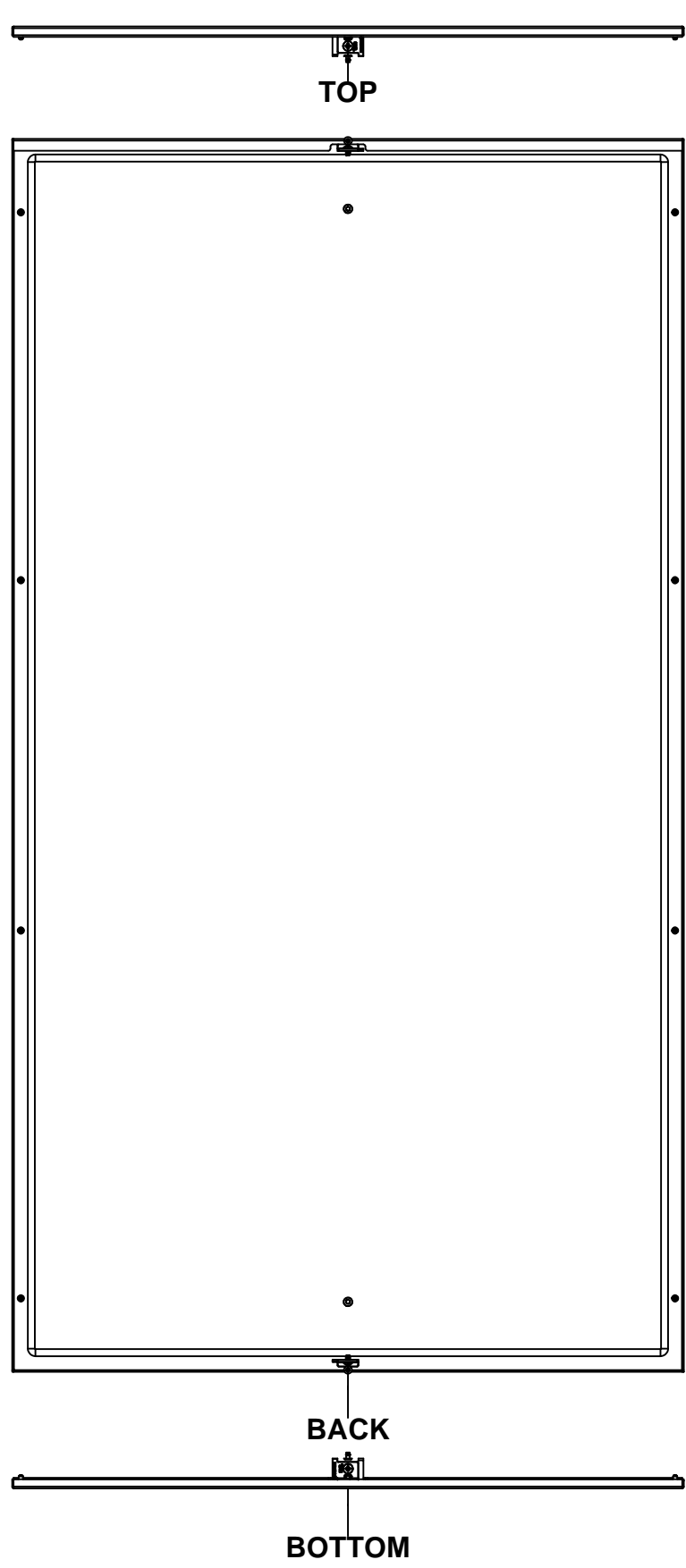

No.	Revisions	Date	By/Par

**Isometric View**

		Flatness Aplatissement Max 3.0mm	
Tél: (450) 979-4373 Fax: (450) 979-4626 <a href="http://www.exmweb.com">www.exmweb.com</a>		Projection 	
Customer Client		Date	
Drawn By Dessiné Par BoxCad: Annie		Date 12/02/2015	
Material Matière		14 Ga H.R.P. & O. (1.7mm)	
Color Couleur	Light Grey RAL7035	Finish Fini	Rough Textured
Description		Detail Rev.	
6500 MXC 1800mm x 1000mm Left			
Part Number Numéro Pièce		Rev.	1
<b>6500MXK180610L</b>		<b>0</b>	3

**SEE BILL OF MATERIAL ON LAST PAGE**

This drawing is confidential and must not be reproduced or used without the consent of EXM

Ce dessin est confidentiel et ne doit pas être reproduit ou utilisé sans le consentement de EXM

STANDARD FEATURES ARE NOT LISTED IN THIS HOLE TABLE			
HOLE TABLE - FRONT VIEW (CUSTOM FEATURE ONLY)			
CUT-OUT	XDIM	YDIM	DESCRIPTION
1	480.0	100.0	GND STUD M6 x 16mm (Inside)
2	480.0	1660.0	GND STUD M6 x 16mm (Inside)

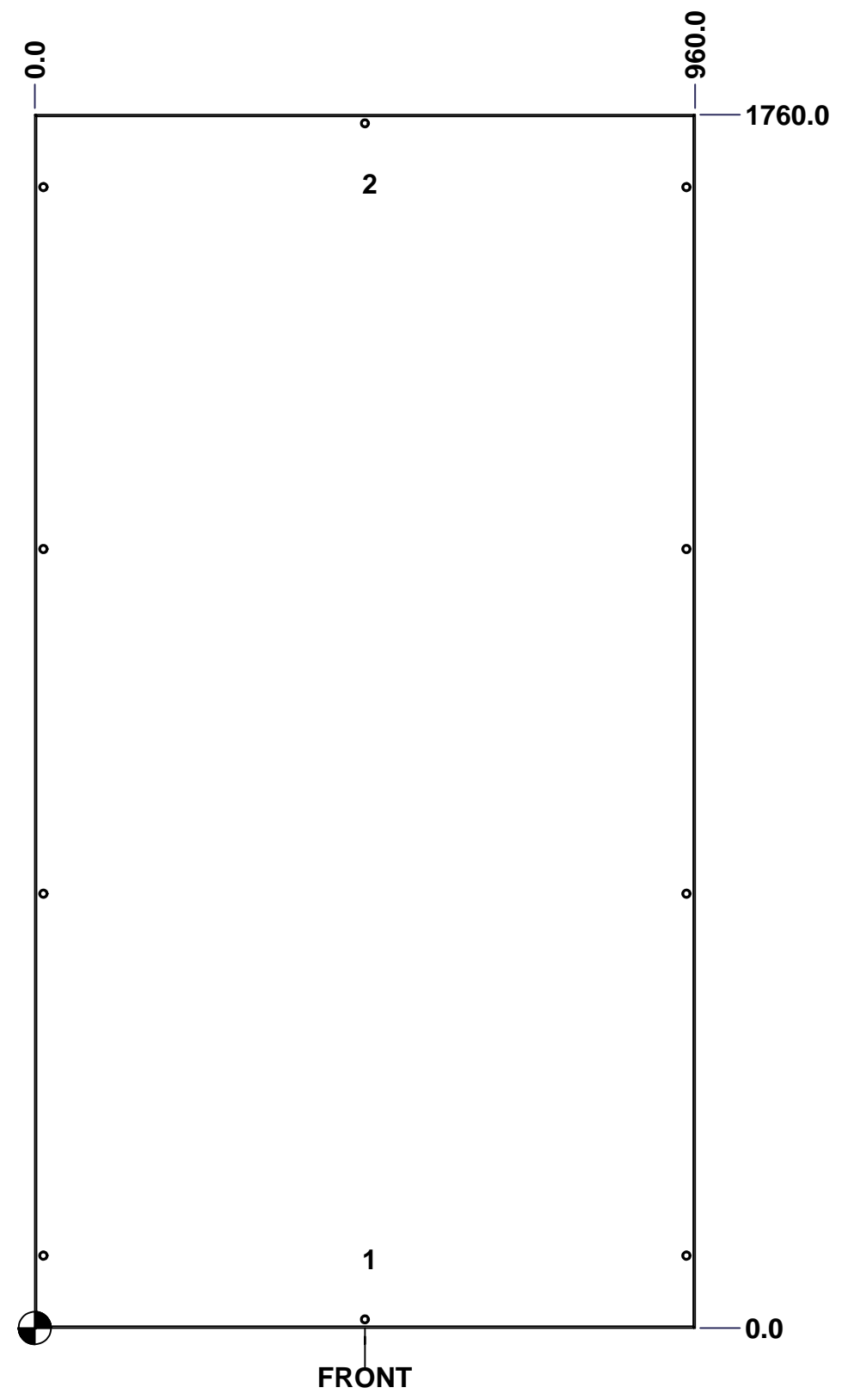



	Description	Status
	6500 MXC 1800mm x 1000mm Left	(NULL)
	Part Number	Rev.
	Numéro Pièce <b>6500MXK180610L</b>	<b>0</b>
		2
		3

This drawing is confidential and must not be reproduced or used without the consent of EXM

Ce dessin est confidentiel et ne doit pas être reproduit ou utilisé sans le consentement de EXM

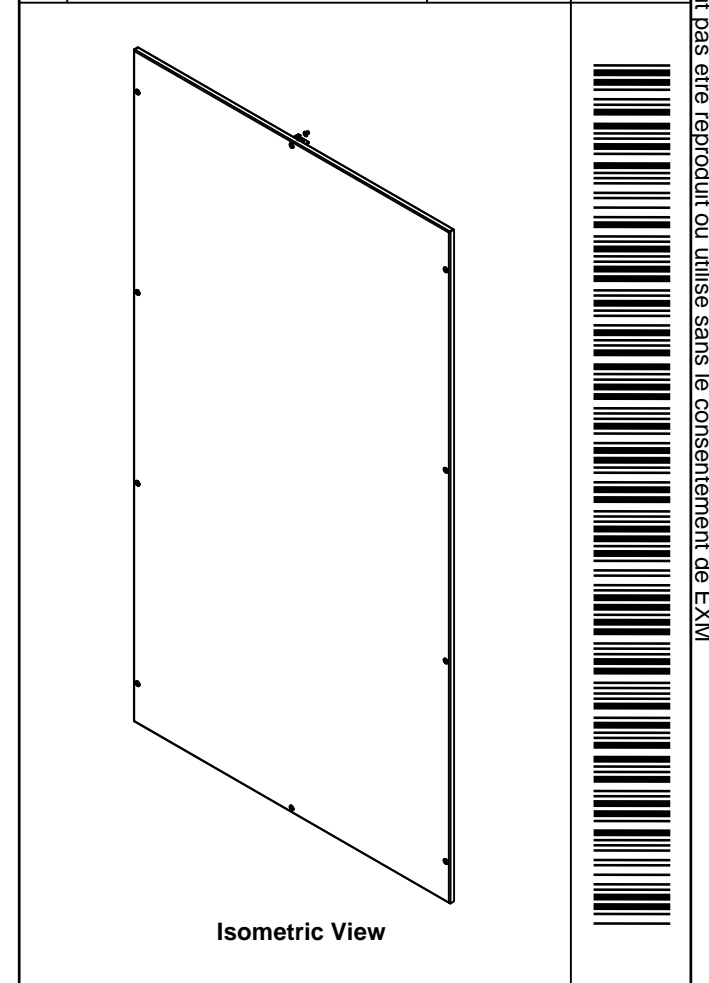
No.	Revisions	Date	By/Par

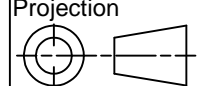

 Tél: (450) 979-4373 Fax: (450) 979-4626 <a href="http://www.exmweb.com">www.exmweb.com</a>		Flatness Aplatissement Max 3.0mm Projection 	
Customer Client		Date	
Drawn By Dessiné Par BoxCad: Annie		Date 12/02/2015	
Material Matière		14 Ga H.R.P. & O. (1.7mm)	
Color Couleur	Light Grey RAL7035	Finish Fini	Rough Textured
Description		Detail Rev.	
6500 MXC 1800mm x 1000mm Left			
Part Number Numéro Pièce		Rev.	3
<b>6500MXK180610L</b>		<b>0</b>	<b>3</b>

Qty	Part Number	Rev	Description
1	STK-P-03820R	0	Powder Paint (Light Grey / Rough Textured)
2	STK-Q-77120	1	6500MX-Frame Rubber Plug
10	STK-Q-03072	2	M6 x 17mm Phillips Flat Head Screw
2	STK-Q-16080	0.1.1	M6 x 16mm Ground Stud
1	6500MXK180610LG	0	6500 MXC 1800mm x 1000mm Left Gasket
1	6500MXK180610L-P	0	6500 MXC 1800mm x 1000mm Left Part
2	STK-K-11010	3	Partial Fixed Bracket Kit
Parts List			

This drawing is confidential and must not be reproduced or used without the consent of EXM

Ce dessin est confidentiel et ne doit pas être reproduit ou utilisé sans le consentement de EXM

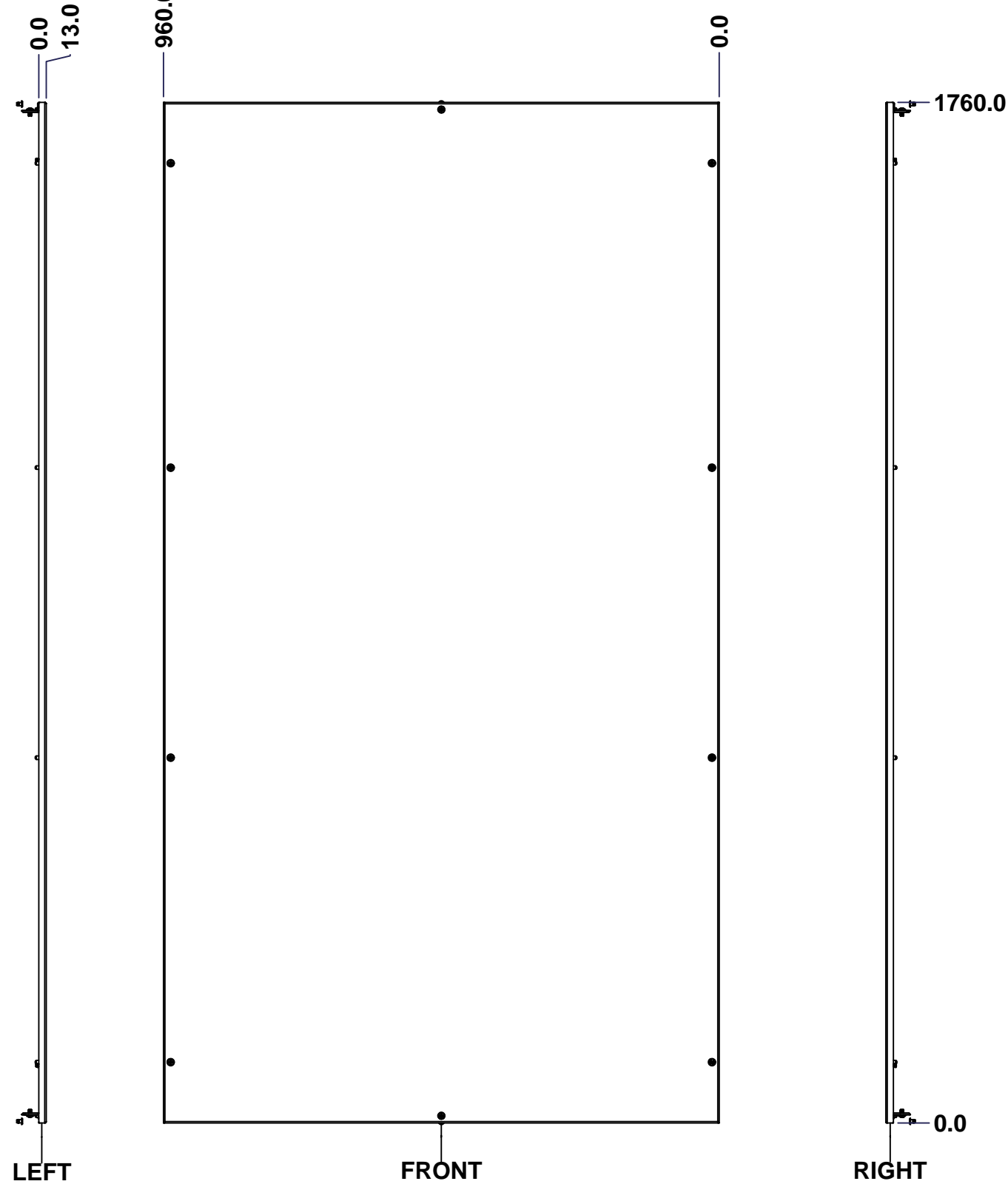
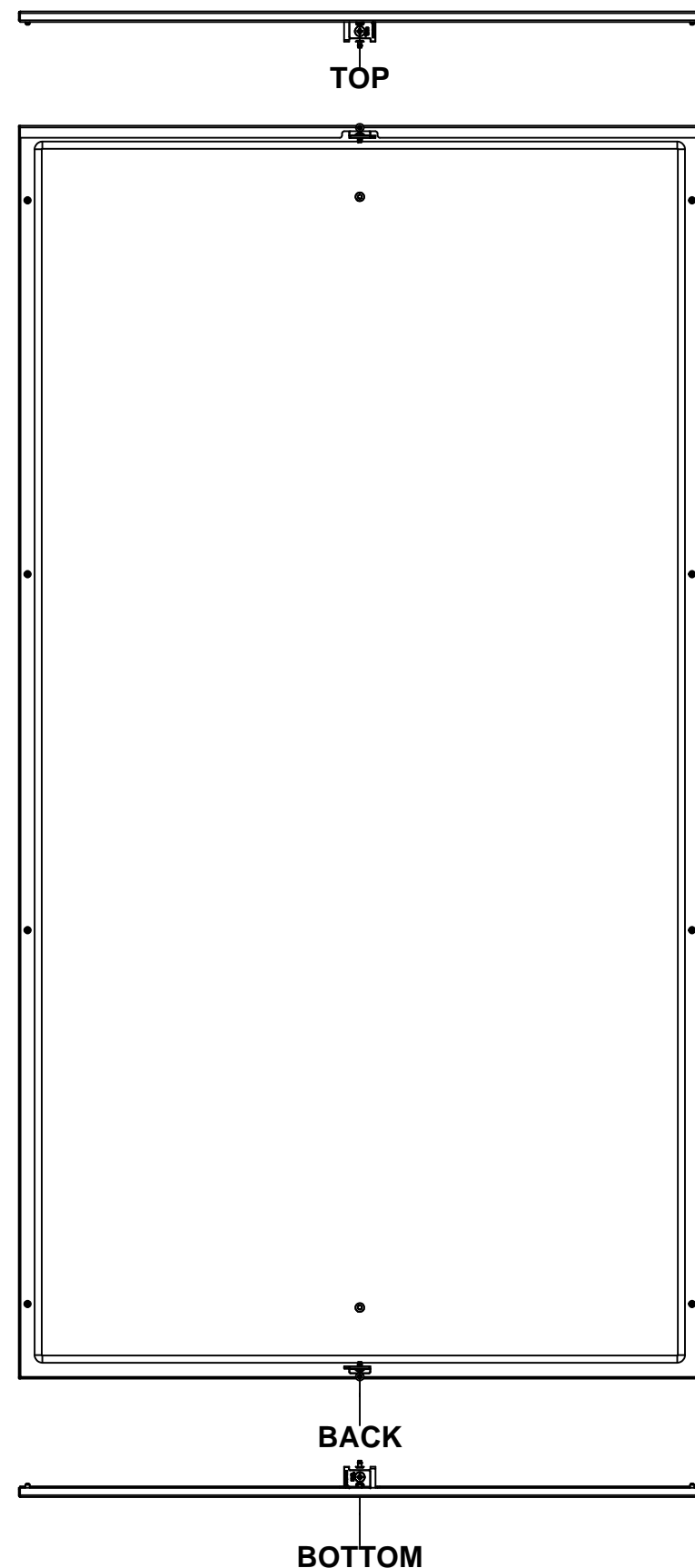

No.	Revisions	Date	By/Par

**Isometric View**

		Flatness Aplatissement Max 3.0mm	
Tél: (450) 979-4373 Fax: (450) 979-4626 <a href="http://www.exmweb.com">www.exmweb.com</a>		Projection 	
Customer Client		Date	
Drawn By Dessiné Par BoxCad: Annie		Date 12/02/2015	
Material Matière		14 Ga H.R.P. & O. (1.7mm)	
Color Couleur	Light Grey RAL7035	Finish Fini	Rough Textured
Description		Detail Rev.	
6500 MXC 1800mm x 1000mm Right			
Part Number Numéro Pièce		Rev.	1
<b>6500MXK180610R</b>		<b>0</b>	3

**SEE BILL OF MATERIAL ON LAST PAGE**

This drawing is confidential and must not be reproduced or used without the consent of EXM

Ce dessin est confidentiel et ne doit pas être reproduit ou utilisé sans le consentement de EXM

STANDARD FEATURES ARE NOT LISTED IN THIS HOLE TABLE			
HOLE TABLE - FRONT VIEW (CUSTOM FEATURE ONLY)			
CUT-OUT	XDIM	YDIM	DESCRIPTION
1	480.0	100.0	GND STUD M6 x 16mm (Inside)
2	480.0	1660.0	GND STUD M6 x 16mm (Inside)

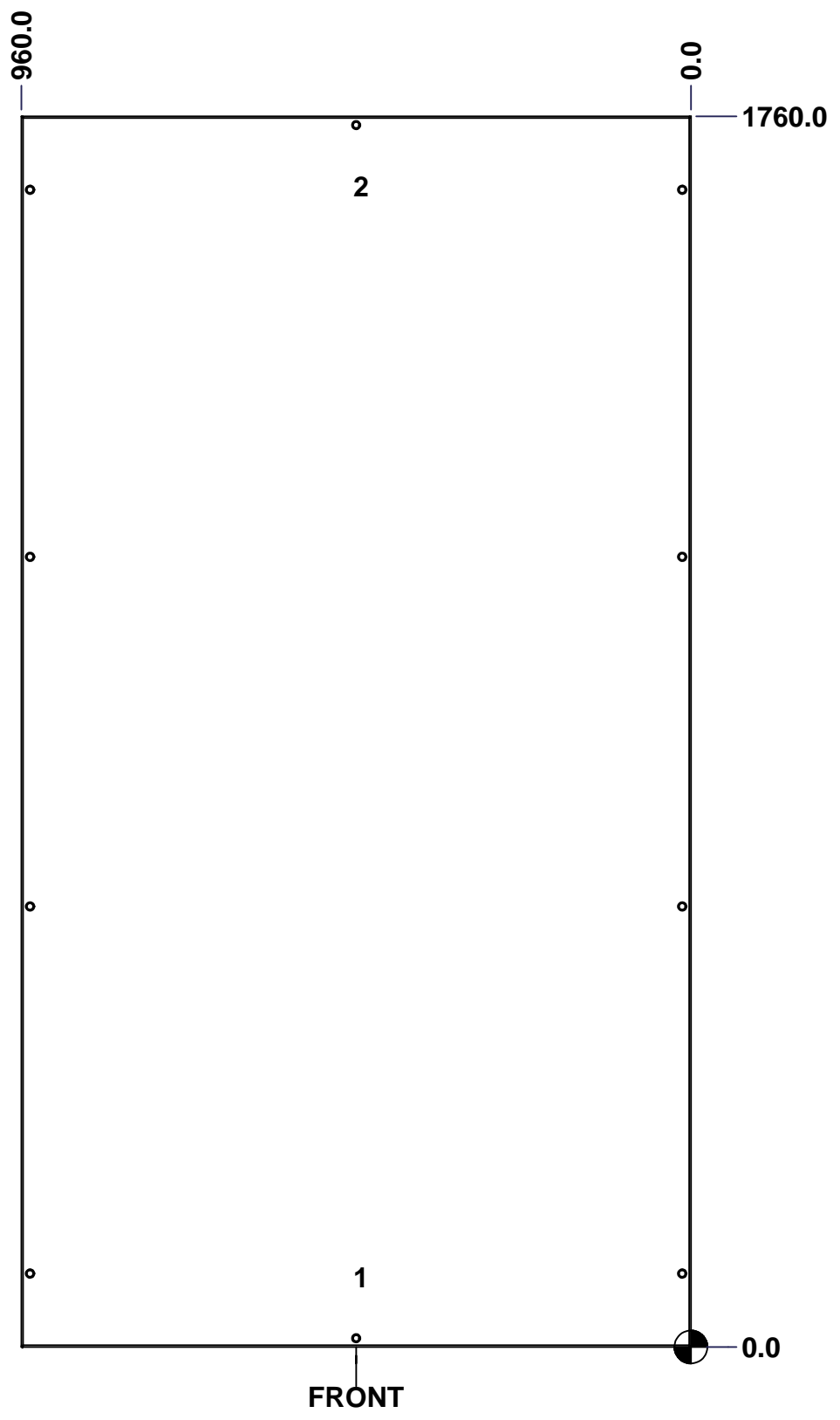



	Description	Status
	6500 MXC 1800mm x 1000mm Right	(NULL)
	Part Number Numéro Pièce	Rev.
	<b>6500MXK180610R</b>	<b>0</b>
		2
		3

This drawing is confidential and must not be reproduced or used without the consent of EXM

Ce dessin est confidentiel et ne doit pas être reproduit ou utilisé sans le consentement de EXM

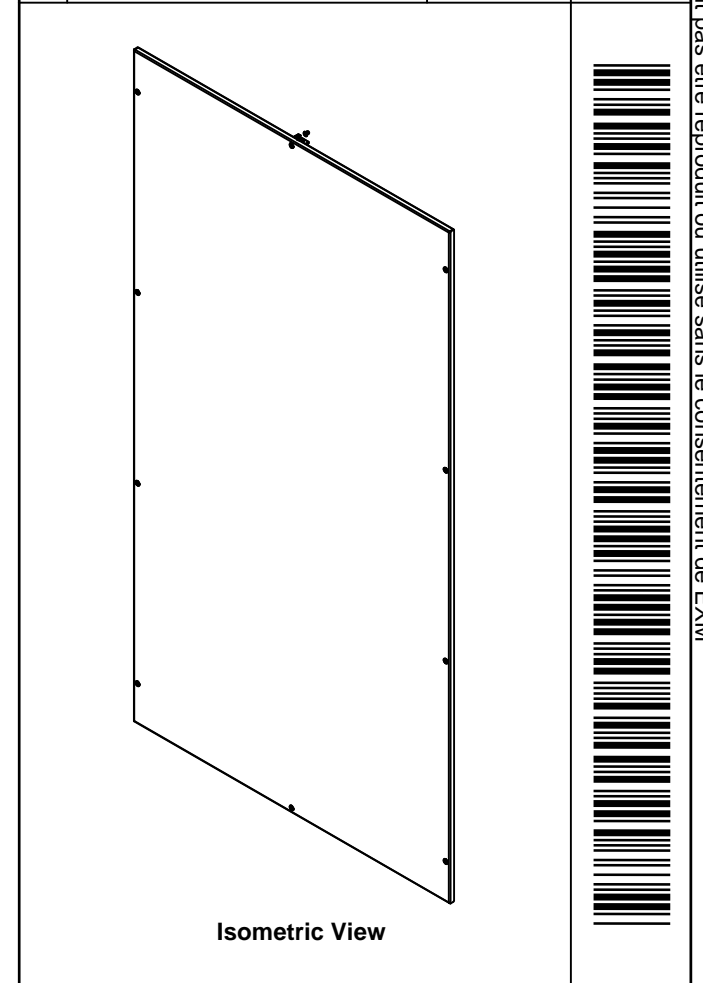
No.	Revisions	Date	By/Par

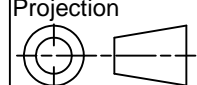

 Tél: (450) 979-4373 Fax: (450) 979-4626 <a href="http://www.exmweb.com">www.exmweb.com</a>		Flatness Aplatissement Max 3.0mm Projection 	
Customer Client		Date	
Drawn By Dessiné Par BoxCad: Annie		Date 12/02/2015	
Material Matière		14 Ga H.R.P. & O. (1.7mm)	
Color Couleur	Light Grey RAL7035	Finish Fini	Rough Textured
Description		Detail Rev.	
6500 MXC 1800mm x 1000mm Right			
Part Number Numéro Pièce		Rev.	3
<b>6500MXK180610R</b>		<b>0</b>	<b>3</b>

Qty	Part Number	Rev	Description
1	STK-P-03820R	0	Powder Paint (Light Grey / Rough Textured)
2	STK-Q-77120	1	6500MX-Frame Rubber Plug
10	STK-Q-03072	2	M6 x 17mm Phillips Flat Head Screw
2	STK-Q-16080	0.1.1	M6 x 16mm Ground Stud
1	6500MXK180610LG	0	6500 MXC 1800mm x 1000mm Left Gasket
1	6500MXK180610L-P	0	6500 MXC 1800mm x 1000mm Left Part
2	STK-K-11010	3	Partial Fixed Bracket Kit
Parts List			

This drawing is confidential and must not be reproduced or used without the consent of EXM

Ce dessin est confidentiel et ne doit pas être reproduit ou utilisé sans le consentement de EXM

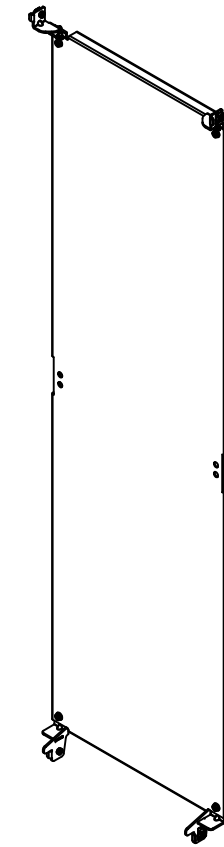
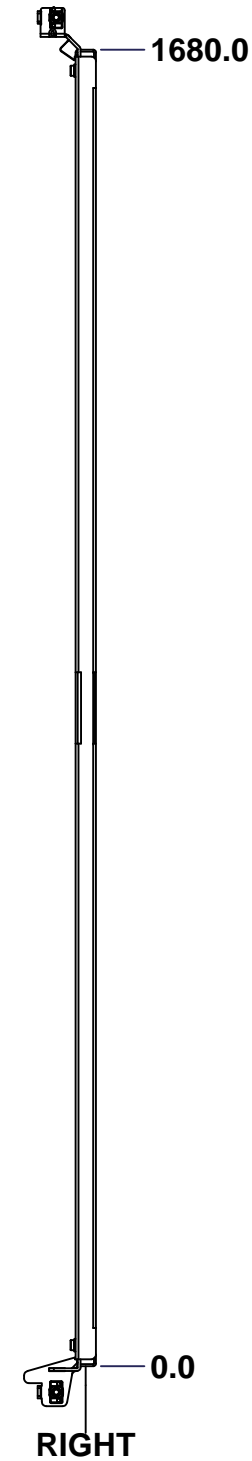
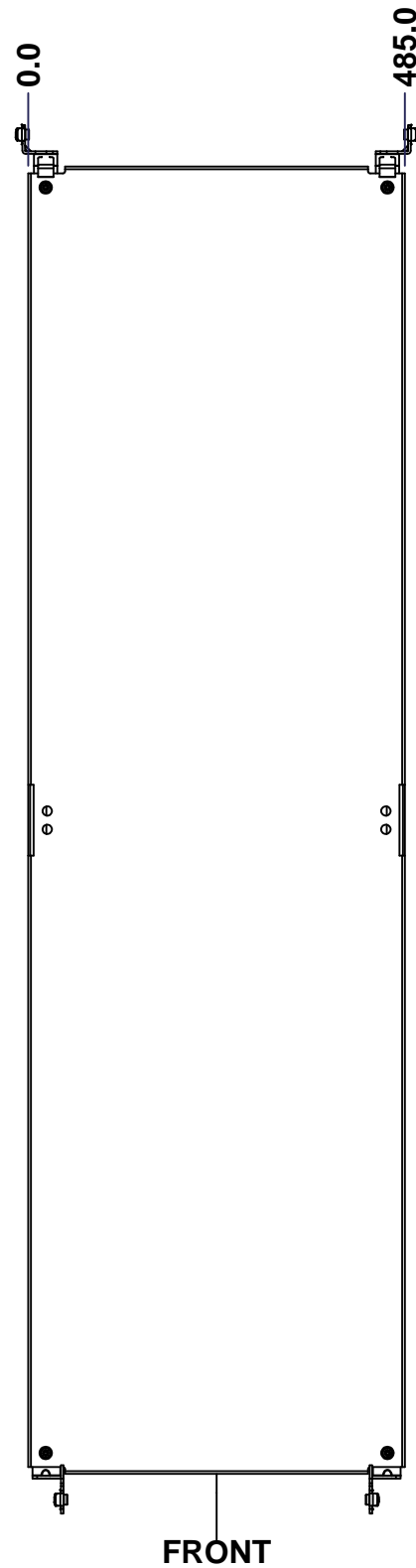
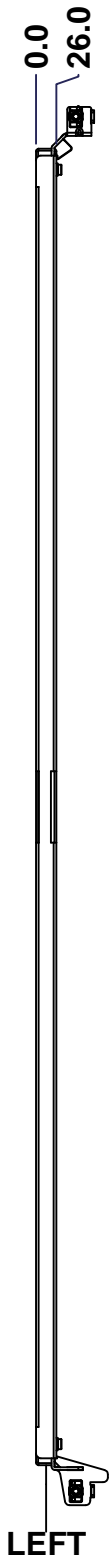
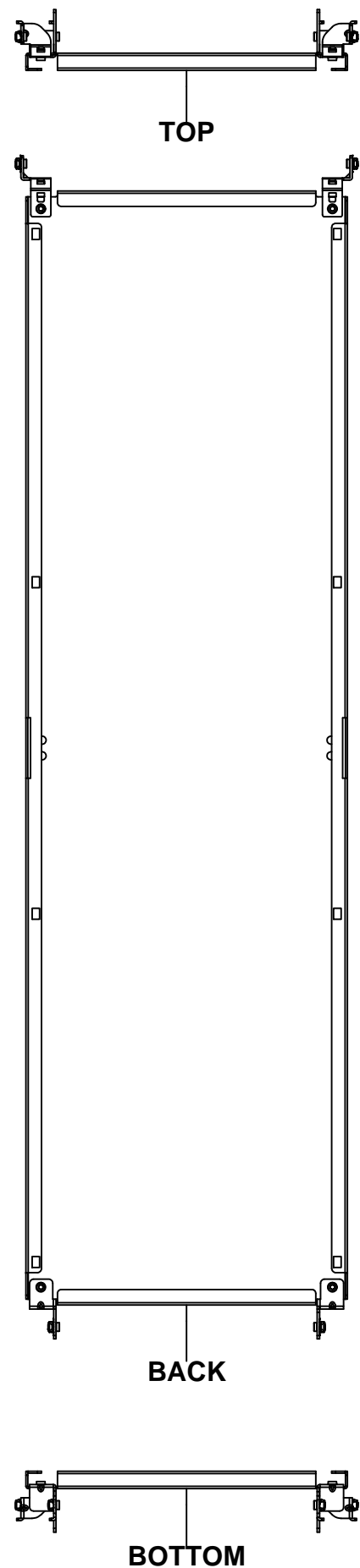

Isometric View



No.	Revisions	Date	By/Par

		Flatness Aplatissement Max 3.0mm Projection 	
Tél: (450) 979-4373 Fax: (450) 979-4626 <a href="http://www.exmweb.com">www.exmweb.com</a>		Date Date 12/02/2015	
Customer Client		Date	
Drawn By Dessiné Par BoxCad: Annie		Date 12/02/2015	
Material Matière 12 Ga Galvanized (2.5mm)		Finish Fini Unpainted	
Color Couleur Unpainted		Finish Fini Unpainted	
Description 6500 MXM 1800mm x 600mm Back Inner Panel		Detail Rev.	
Part Number Numéro Pièce <b>6500MXK180610BIP</b>		Rev. 1 <b>0</b> / 3	

SEE BILL OF MATERIAL ON LAST PAGE

This drawing is confidential and must not be reproduced or used without the consent of EXM

Ce dessin est confidentiel et ne doit pas être reproduit ou utilisé sans le consentement de EXM

No.	Revisions	Date	By/Par

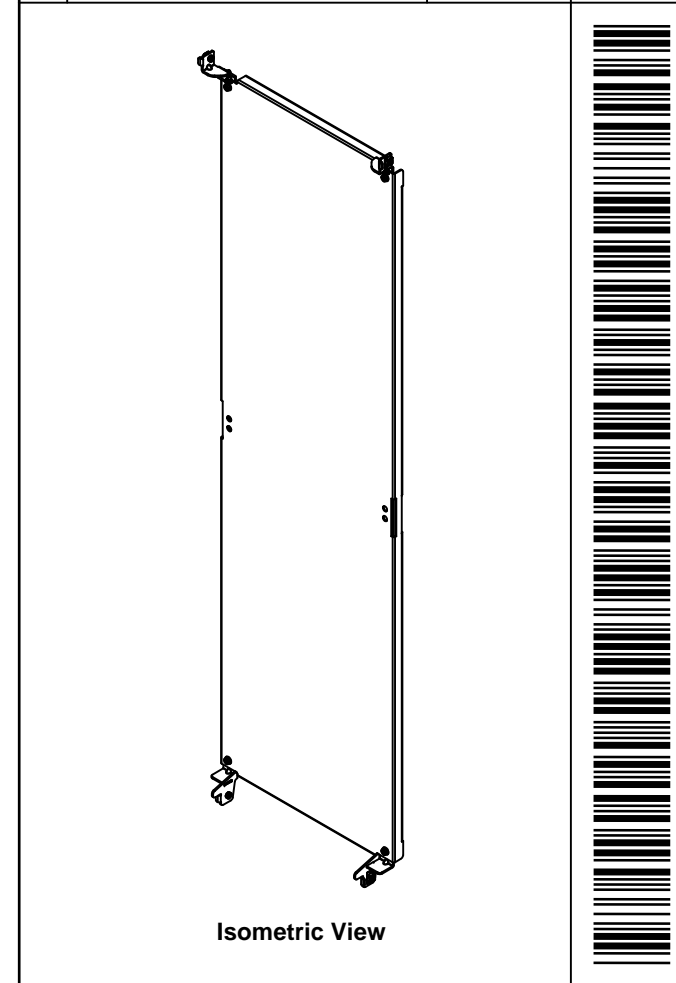

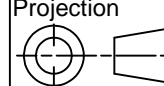
 Tél: (450) 979-4373 Fax: (450) 979-4626 <a href="http://www.exmweb.com">www.exmweb.com</a>		Flatness Aplatissement Max 3.0mm Projection 
Customer Client	Date	
Drawn By Dessiné Par	BoxCad: Annie	Date 12/02/2015
Material Matière	12 Ga Galvanized (2.5mm)	
Color Couleur	Unpainted	Finish Fini Unpainted
Description 6500 MXM 1800mm x 600mm Back Inner Panel		Detail Rev.
Part Number Numéro Pièce	<b>6500MXK180610BIP</b>	Rev. 3
		<b>0</b> 3

Qty	Part Number	Rev	Description
1	STK-A-49005	0	6500MXM - Bottom Inner Panel Support Kit (Right)
1	STK-A-49000	0	6500MXM - Bottom Inner Panel Support Kit (Left)
1	STK-A-49015	0	6500MXM - Top Inner Panel Support Kit (Right)
1	STK-A-49010	0	6500MXM - Top Inner Panel Support Kit (Left)
1	6500MXK180610BIP-P	0	6500 MXM 1800mm x 600mm Back Inner Panel Part
Parts List			