

This drawing is confidential and must not be reproduced or used without the consent of EXM

Ce dessin est confidentiel et ne doit pas être reproduit ou utilisé sans le consentement de EXM

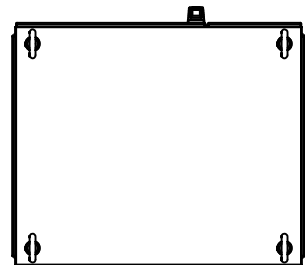

TOP

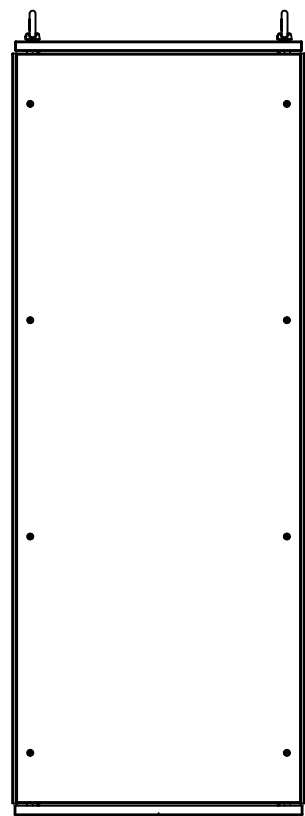

BACK

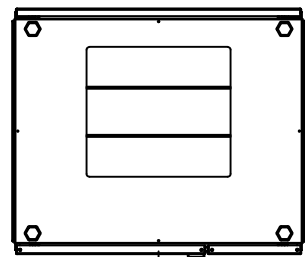

BOTTOM

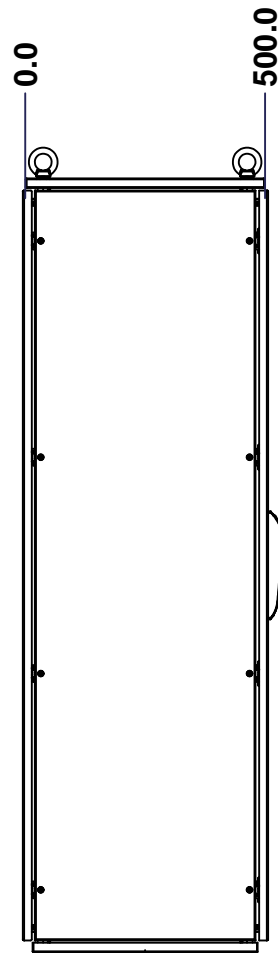

LEFT

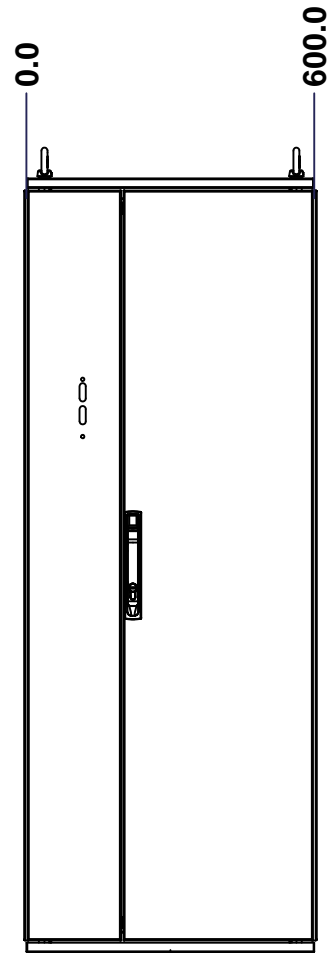

FRONT

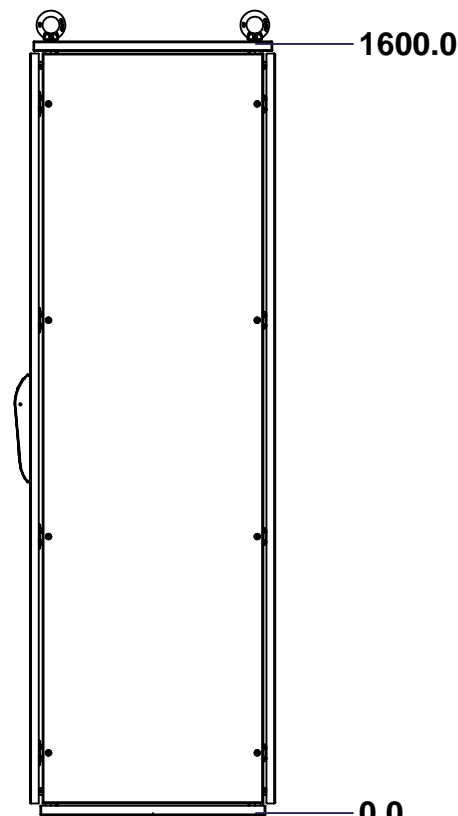

RIGHT

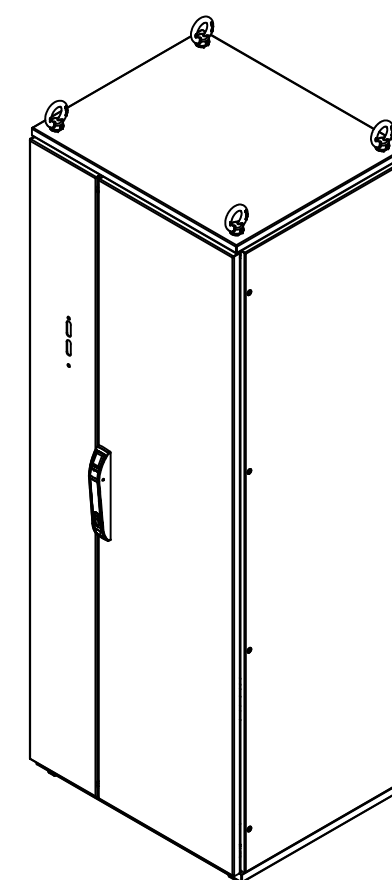

Isometric View

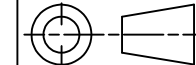

No.	Revisions	Date	By/Par

 Tél: (450) 979-4373 Fax: (450) 979-4626 www.exmweb.com		Flatness Aplatissement Max 3.0mm Projection 
Customer Client	Date	Date
Drawn By Dessiné Par	BoxCad: Annie	Date 04/03/2015
Material Matière	See Part List	
Color Couleur	See Part List	Finish Fini See Part List
Description 6500MX 1600mm x 600mm x 500mm Assembly	Detail Rev.	
Part Number Numéro Pièce	Rev. 0	1 2

SEE BILL OF MATERIAL ON LAST PAGE

6500MXU160605

This drawing is confidential and must not be reproduced or used without the consent of EXM

Ce dessin est confidentiel et ne doit pas être reproduit ou utilisé sans le consentement de EXM

No.	Revisions	Date	By/Par

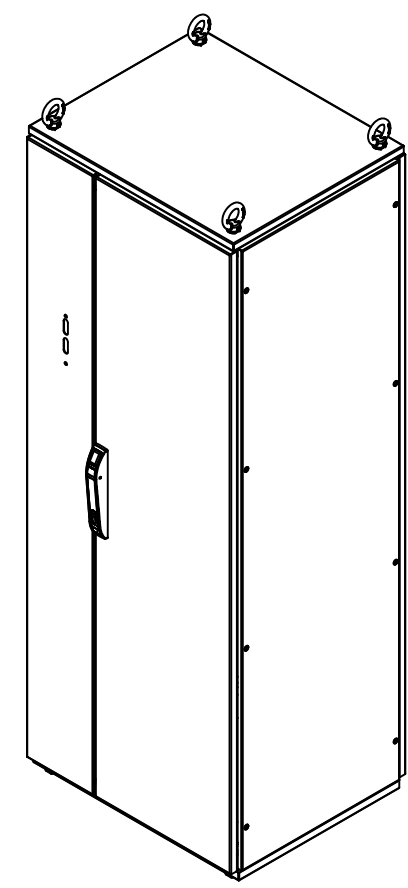

Isometric View

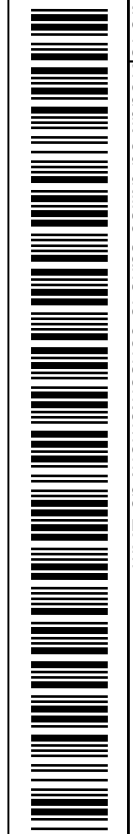

Tél: (450) 979-4373
 Fax: (450) 979-4626
www.exmweb.com

Flatness
Aplatissement
Max 3.0mm
Projection

Customer Client
 Drawn By Dessiné Par BoxCad: Annie
 Date 04/03/2015

Material Matière See Part List

Color Couleur See Part List
 Finish Fini See Part List

Description 6500MX 1600mm x 600mm x 500mm Assembly
 Detail Rev.

Part Number Numéro Pièce **6500MXU160605**
 Rev. 0

1	6500MXU160605BIP	0	6500 MXM 1600mm x 600mm Back Inner Panel
1	6500MXU160605R	0	6500 MXC 1600mm x 500mm Right
1	6500MXU160605L	0	6500 MXC 1600mm x 500mm Left
1	6500MXU160605F	0	6500 MXDU 1600mm x 600mm Front
1	6500MXU160605B	0	6500 MXR 1600mm x 600mm Back
1	6500MXU160605BT	0	6500 MXB 600mm x 500mm Bottom
1	6500MXU160605T	0	6500 MXT 600mm x 500mm Top
1	6500MXU160605FR	0	6500 MX 1600mm x 600mm x 500mm Frame
Qty	Part Number	Rev	Description
Parts List			

Rev.	2
0	2

This drawing is confidential and must not be reproduced or used without the consent of EXM

Ce dessin est confidentiel et ne doit pas être reproduit ou utilisé sans le consentement de EXM

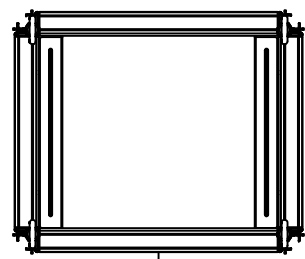

TOP

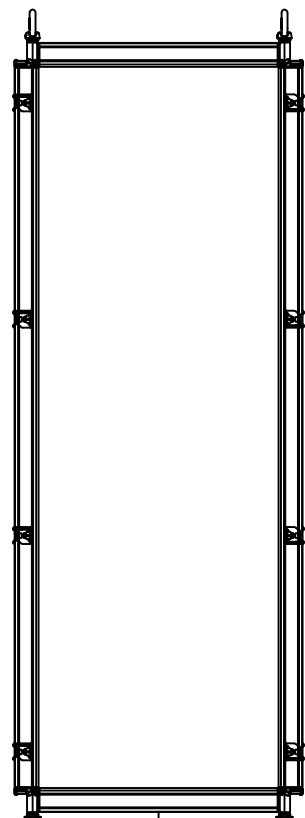

BACK

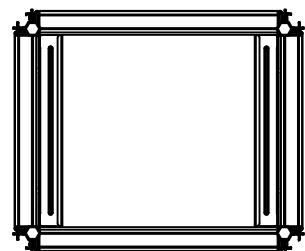

BOTTOM

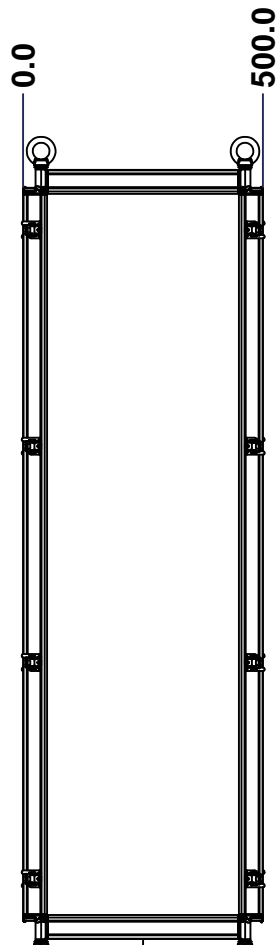

LEFT

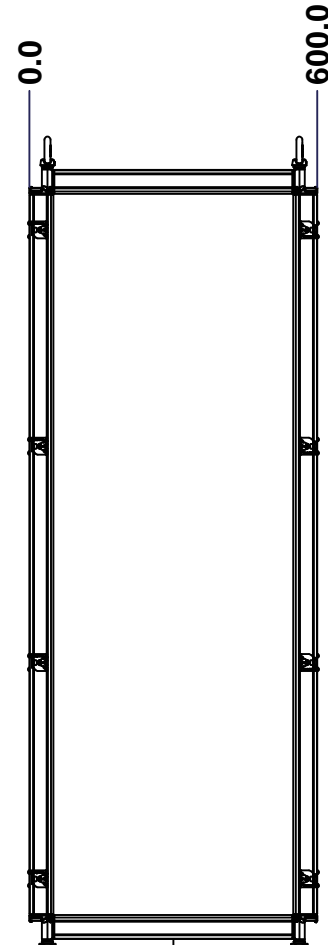

FRONT

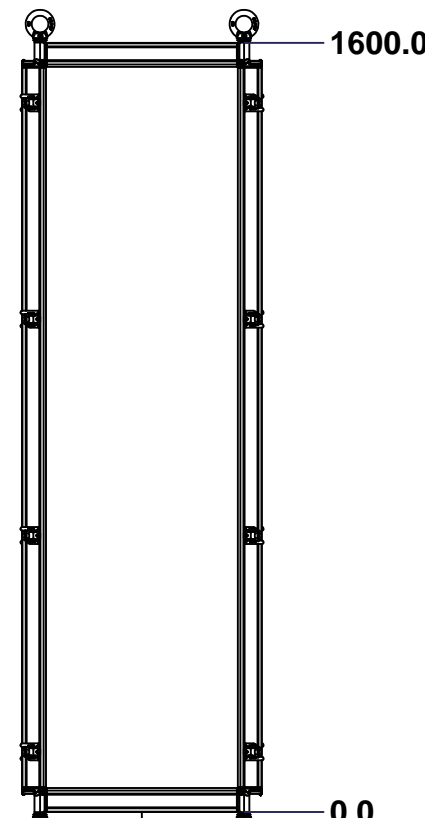

RIGHT

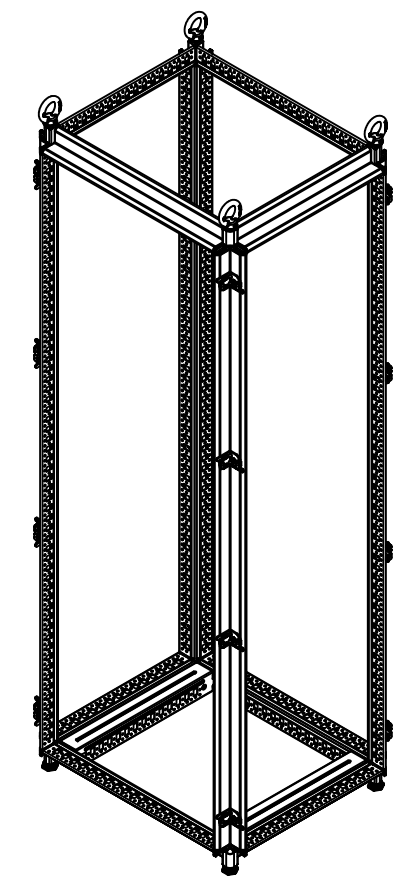

Isometric View

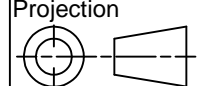

No.	Revisions	Date	By/Par

 Tél: (450) 979-4373 Fax: (450) 979-4626 www.exmweb.com		Flatness Aplatissement Max 3.0mm Projection 
Customer Client	Date	Date
Drawn By Dessiné Par	BoxCad: Annie	Date 04/03/2015
Material Matière 16 Ga Electro-Galvanized (1.4mm)		
Color Couleur	Iron Grey RAL7011	Finish Finis Rough Textured
Description 6500 MX 1600mm x 600mm x 500mm Frame		Detail Rev.
Part Number Numéro Pièce 6500MXU160605FR		Rev. 1 0 2

SEE BILL OF MATERIAL ON LAST PAGE

This drawing is confidential and must not be reproduced or used without the consent of EXM

Ce dessin est confidentiel et ne doit pas être reproduit ou utilisé sans le consentement de EXM

No.	Revisions	Date	By/Par

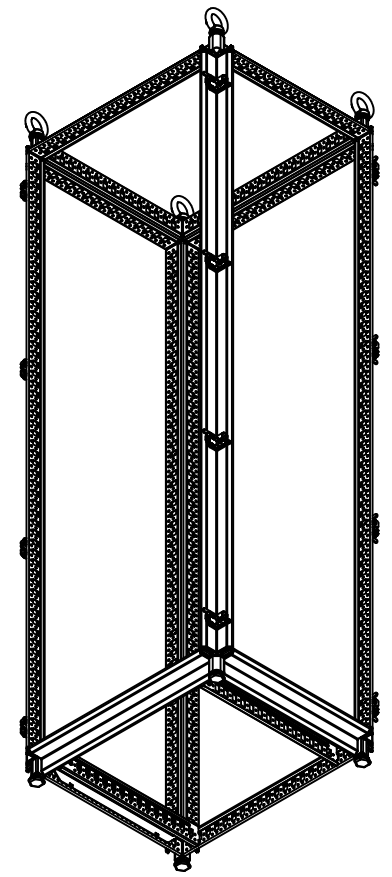

Isometric View



Qty	Part Number	Rev	Description
1	STK-P-03810R	0	Powder Paint (Iron Grey / Rough Textured)
1	STK-Q-49055	3	6500 MXM Inner Panel Slider 500mm
1	STK-Q-49055-L	3	6500 MXM Inner Panel Slider 500mm
4	STK-Q-49500	3	M12 Eye Bolt (0.34T)
4	STK-Q-61110	0	M12 Feet Leveler
8	STK-Q-00610	1	M18 x 30.5mm Bolt - Cover
4	STK-Q-47251-16	3	6500 MX 1600mm Vertical Frame Post Part
4	STK-Q-47250-06	3	6500 MX 600mm Horizontal Frame Post Part
4	STK-Q-47250-05	3	6500 MX 500mm Horizontal Frame Post Part
8	STK-Q-49445	2	6500 MX - Frame Corner Bracket Casting
16	STK-K-11001	2	3 Way Fixed Bracket Kit
Parts List			

		Tél: (450) 979-4373 Fax: (450) 979-4626 www.exmweb.com		Flatness Aplatissement Max 3.0mm	
Customer Client		Date		Projection 	
Drawn By Dessiné Par		BoxCad: Annie		Date 04/03/2015	
Material Matière		16 Ga Electro-Galvanized (1.4mm)			
Color Couleur		Iron Grey RAL7011		Finish Fini Rough Textured	
Description 6500 MX 1600mm x 600mm x 500mm Frame				Detail Rev.	
Part Number Numéro Pièce 6500MXU160605FR				Rev. 2 0	

This drawing is confidential and must not be reproduced or used without the consent of EXM

Ce dessin est confidentiel et ne doit pas être reproduit ou utilisé sans le consentement de EXM



TOP

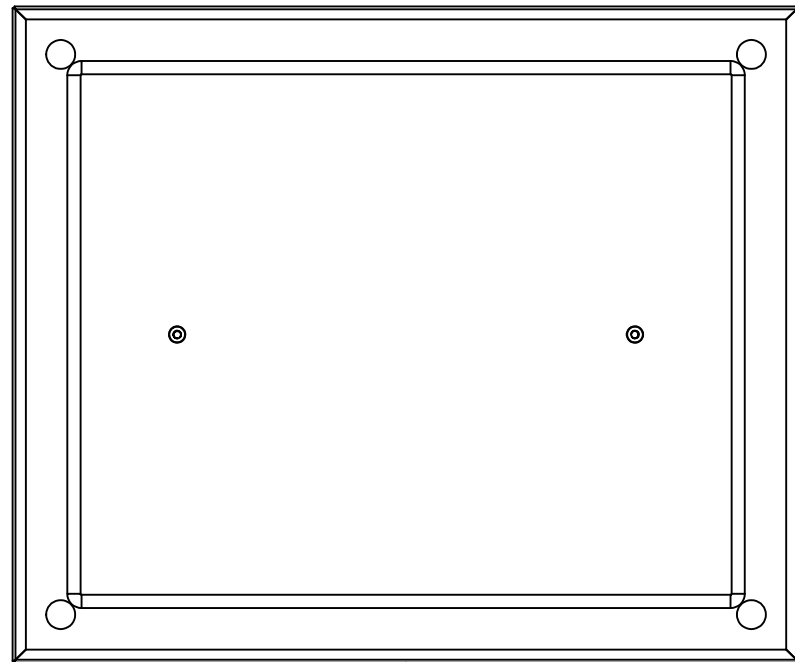

BACK

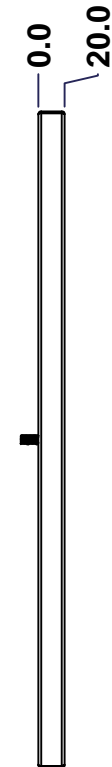

LEFT

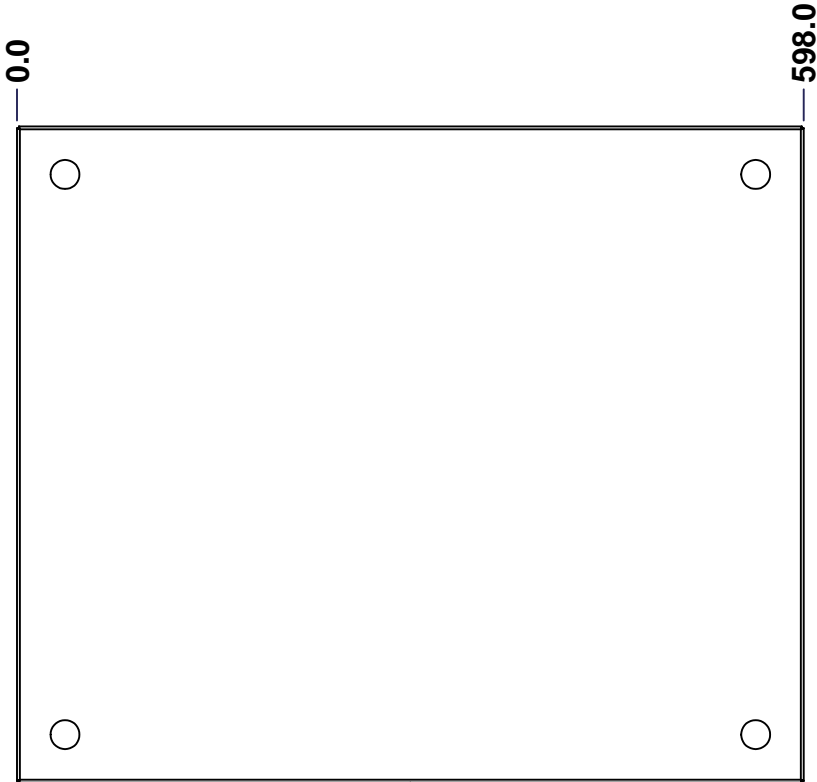

FRONT

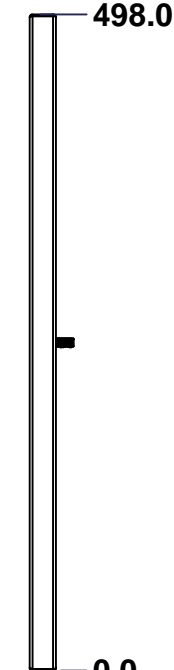

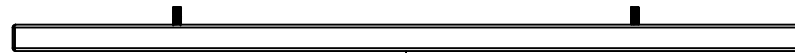

RIGHT

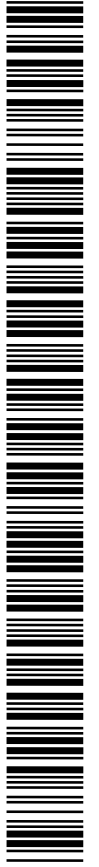
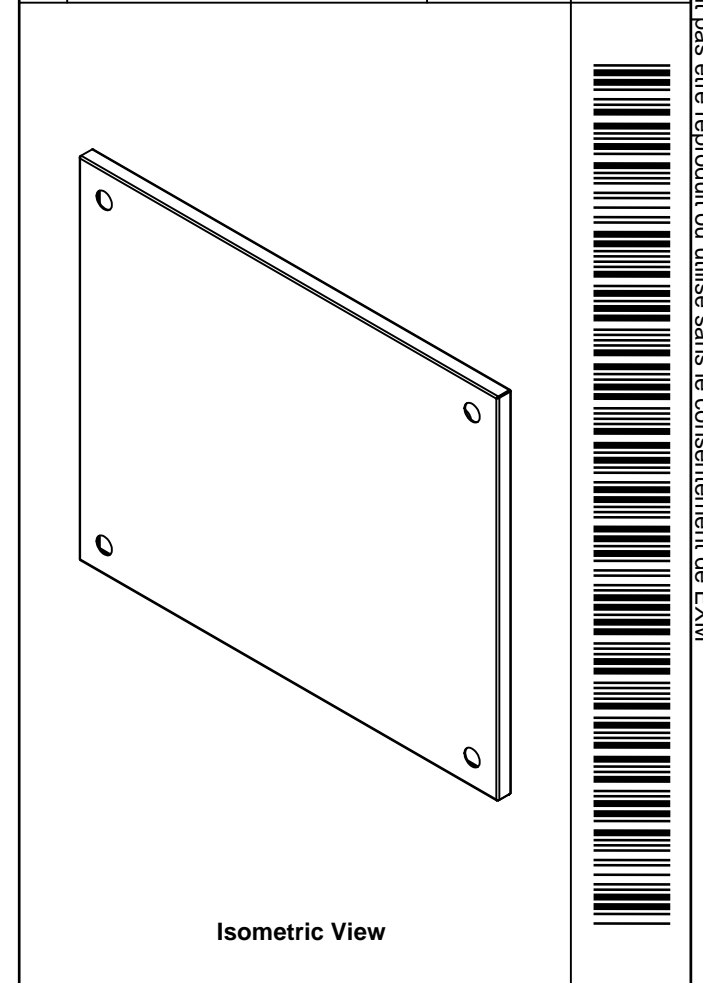

BOTTOM

No.	Revisions	Date	By/Par

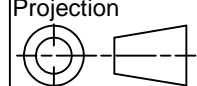

 Tél: (450) 979-4373 Fax: (450) 979-4626 www.exmweb.com		Flatness Aplatissement Max 3.0mm Projection 
Customer Client	Date	Date
Drawn By Dessiné Par	BoxCad: Annie	Date 04/03/2015
Material Matière 16 Ga H.R.P. & O. (1.4mm)		
Color Couleur	Iron Grey RAL7011	Finish Fini Rough Textured
Description 6500 MXT 600mm x 500mm Top		Detail Rev.
Part Number Numéro Pièce 6500MXU160605T		Rev. 1 0 3

SEE BILL OF MATERIAL ON LAST PAGE

This drawing is confidential and must not be reproduced or used without the consent of EXM

Ce dessin est confidentiel et ne doit pas être reproduit ou utilisé sans le consentement de EXM

STANDARD FEATURES ARE NOT LISTED IN THIS HOLE TABLE			
HOLE TABLE - FRONT VIEW (CUSTOM FEATURE ONLY)			
CUT-OUT	XDIM	YDIM	DESCRIPTION
1	125.0	249.0	GND STUD M6 x 16mm (Inside)
2	473.0	249.0	GND STUD M6 x 16mm (Inside)

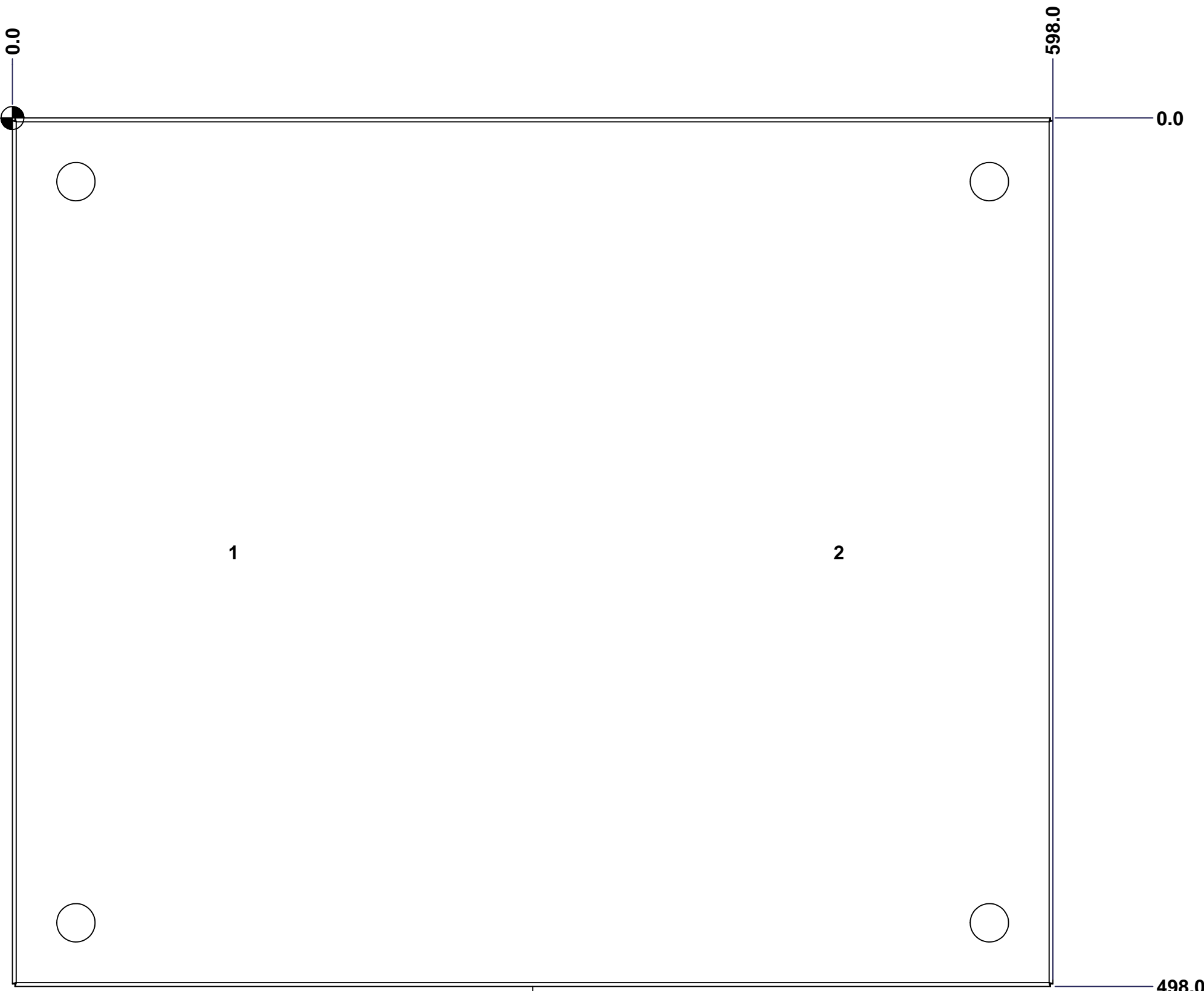

FRONT

	Description	Status
	6500 MXT 600mm x 500mm Top	(NULL)
	Part Number Numéro Pièce	Rev.
	6500MXU160605T	0
		2
		3

This drawing is confidential and must not be reproduced or used without the consent of EXM

Ce dessin est confidentiel et ne doit pas être reproduit ou utilisé sans le consentement de EXM

No.	Revisions	Date	By/Par

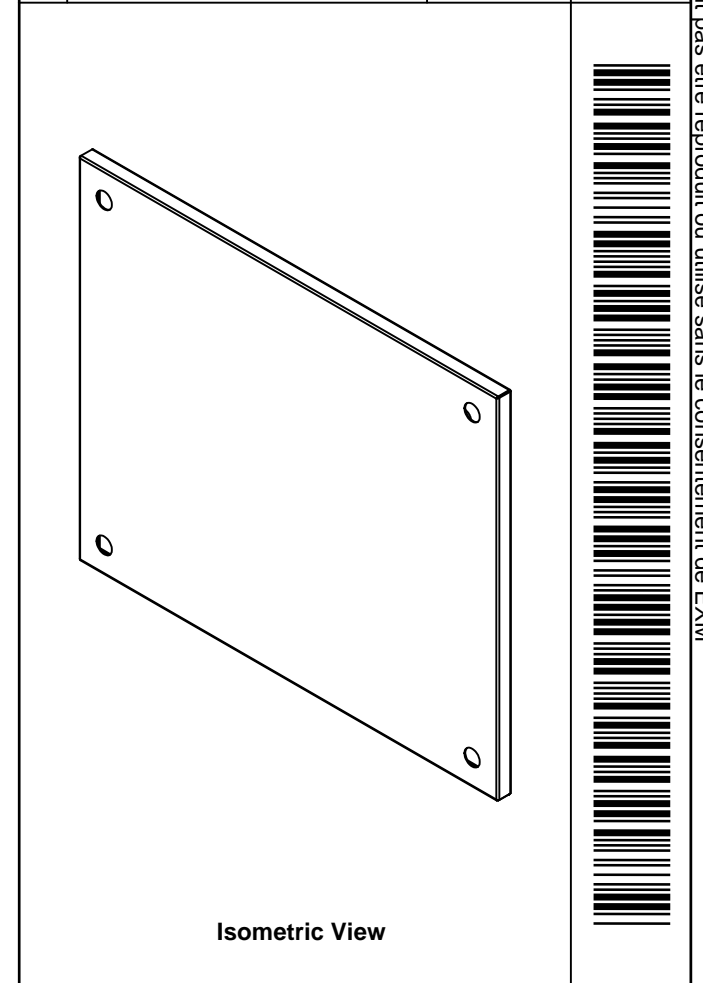

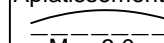
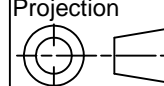
 Tél: (450) 979-4373 Fax: (450) 979-4626 www.exmweb.com		Flatness Aplatissement  Max 3.0mm Projection 
Customer Client	Date	
Drawn By Dessiné Par	BoxCad: Annie	Date 04/03/2015
Material Matière	16 Ga H.R.P. & O. (1.4mm)	
Color Couleur	Iron Grey RAL7011	Finish Fini Rough Textured
Description		Detail Rev.
6500 MXT 600mm x 500mm Top		
Part Number Numéro Pièce	Rev.	3
6500MXU160605T	0	3

Qty	Part Number	Rev	Description
1	STK-P-03810R	0	Powder Paint (Iron Grey / Rough Textured)
2	STK-Q-16080	0.1.1	M6 x 16mm Ground Stud
1	6500MXU160605TG	0	6500 MXT 600mm x 500mm Top Gasket
1	6500MXU160605T-P	0	6500 MXT 600mm x 500mm Top Part
Parts List			

This drawing is confidential and must not be reproduced or used without the consent of EXM

Ce dessin est confidentiel et ne doit pas être reproduit ou utilisé sans le consentement de EXM

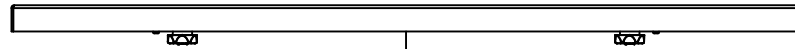

TOP

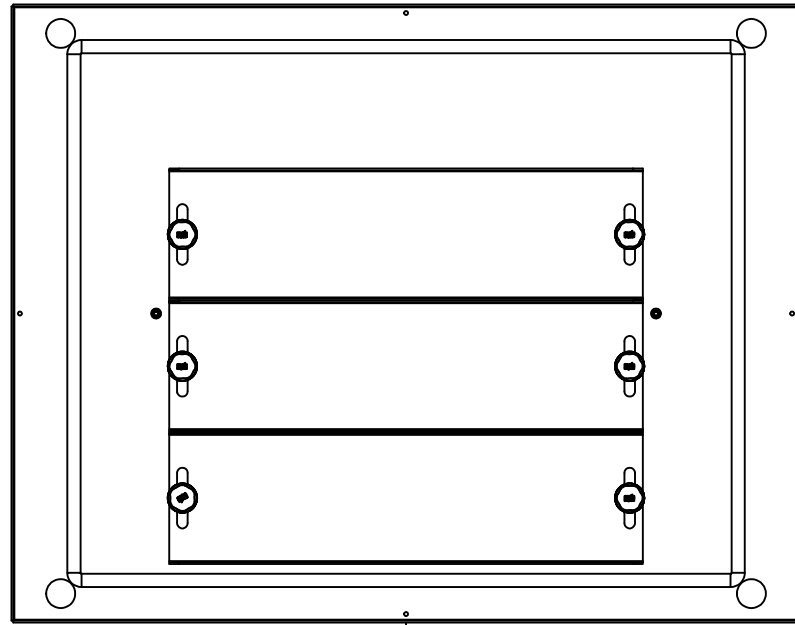

BACK

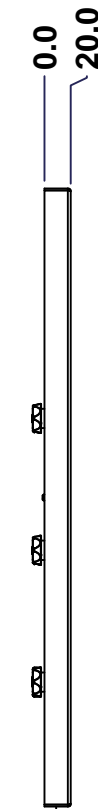

LEFT

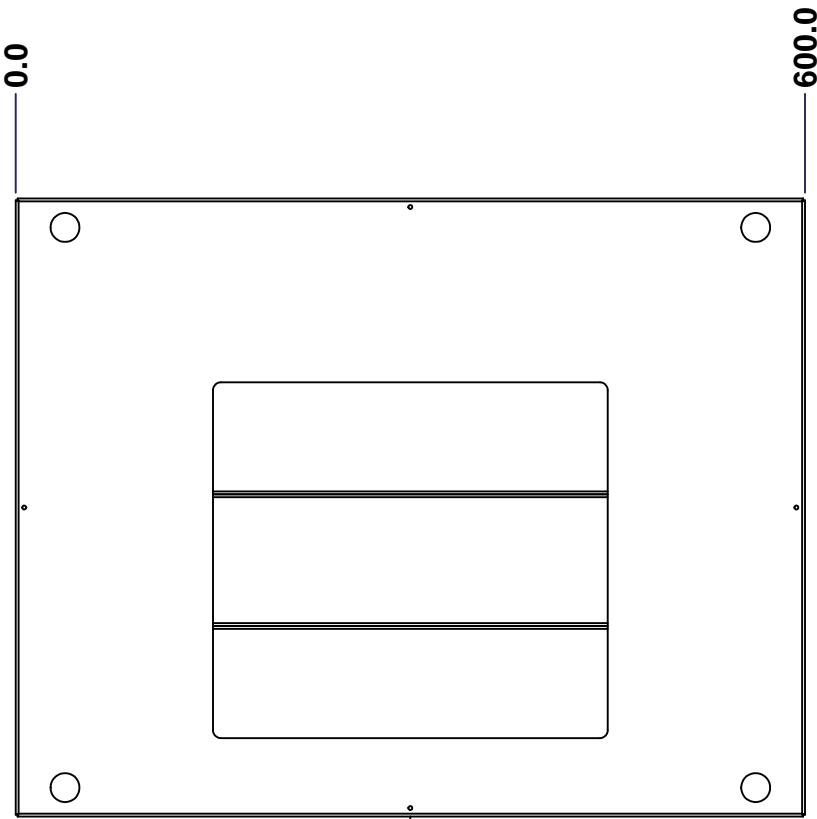

FRONT

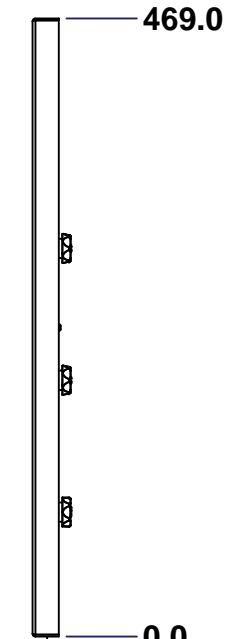

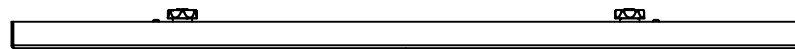

RIGHT

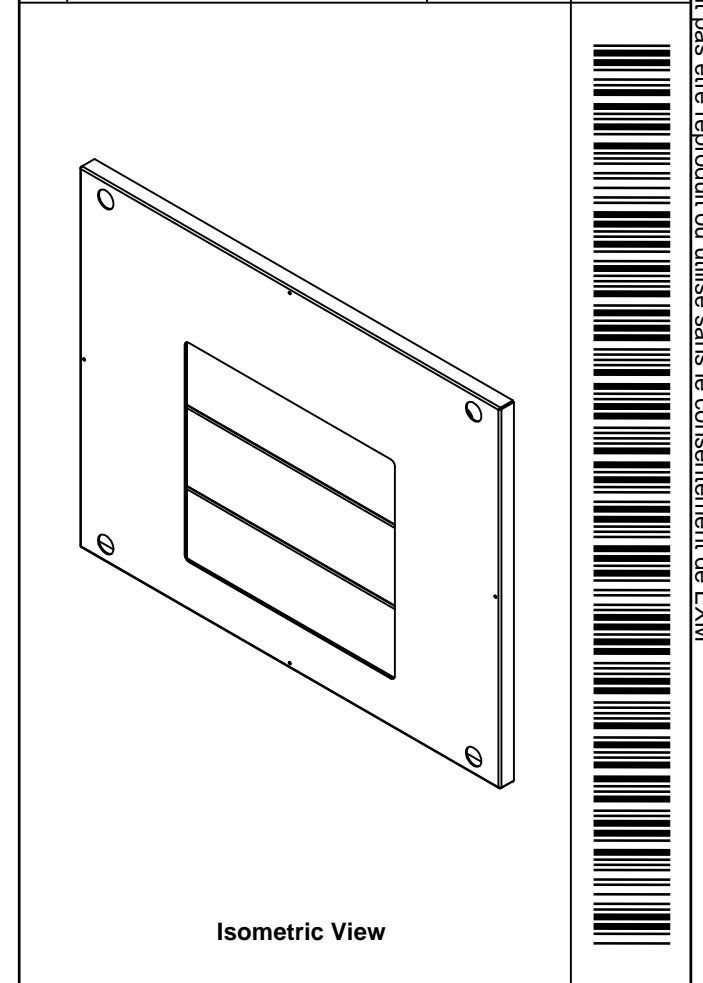

BOTTOM

No.	Revisions	Date	By/Par

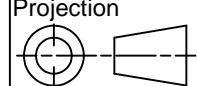

 Tél: (450) 979-4373 Fax: (450) 979-4626 www.exmweb.com		Flatness Aplatissement Max 3.0mm Projection 
Customer Client	Date	
Drawn By Dessiné Par	BoxCad: Annie	Date 04/03/2015
Material Matière	16 Ga H.R.P. & O. (1.4mm)	
Color Couleur	Iron Grey RAL7011	Finish Fini Rough Textured
Description	Detail Rev.	
6500 MXB 600mm x 500mm Bottom		
Part Number Numéro Pièce	Rev.	1 3
6500MXU160605BT	0	

SEE BILL OF MATERIAL ON LAST PAGE

This drawing is confidential and must not be reproduced or used without the consent of EXM

Ce dessin est confidentiel et ne doit pas être reproduit ou utilisé sans le consentement de EXM

STANDARD FEATURES ARE NOT LISTED IN THIS HOLE TABLE

HOLE TABLE - FRONT VIEW (CUSTOM FEATURE ONLY)

CUT-OUT	XDIM	YDIM	DESCRIPTION
1	110.0	234.5	GND STUD M6 x 16mm (Inside)
2	490.0	234.5	GND STUD M6 x 16mm (Inside)
3	130.0	294.5	GP STUD M6 x 10mm (Inside)
4	470.0	294.5	GP STUD M6 x 10mm (Inside)
5	130.0	194.5	GP STUD M6 x 10mm (Inside)
6	470.0	194.5	GP STUD M6 x 10mm (Inside)
7	130.0	94.5	GP STUD M6 x 10mm (Inside)
8	470.0	94.5	GP STUD M6 x 10mm (Inside)

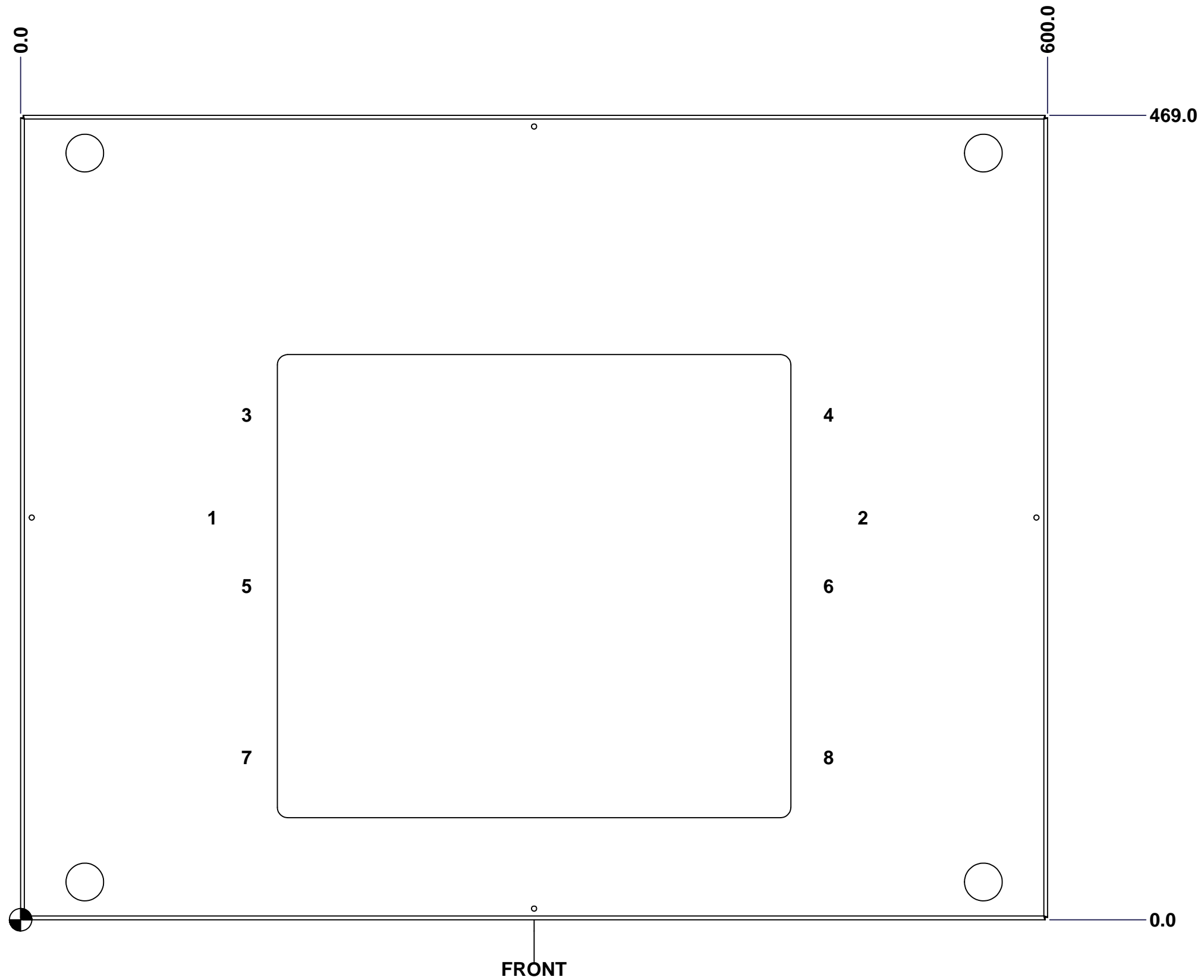

	Description	Status
	6500 MXB 600mm x 500mm Bottom	(NULL)
	Part Number Numéro Pièce	Rev.
	6500MXU160605BT	0
		2
		3

This drawing is confidential and must not be reproduced or used without the consent of EXM

Ce dessin est confidentiel et ne doit pas être reproduit ou utilisé sans le consentement de EXM

No.	Revisions	Date	By/Par

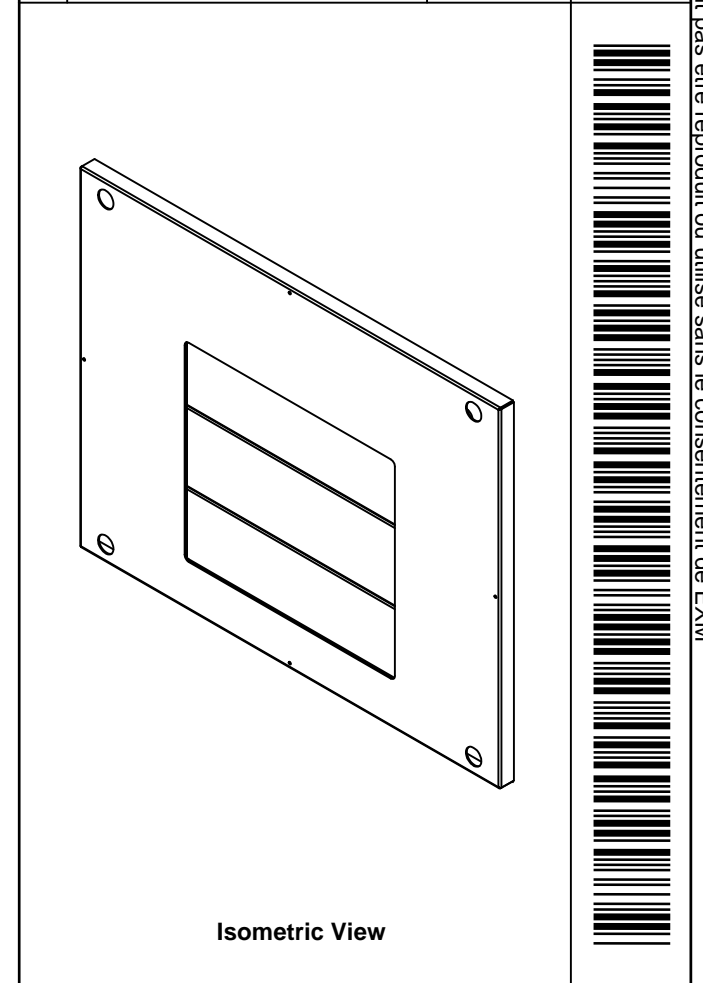

Tél: (450) 979-4373 Fax: (450) 979-4626 www.exmweb.com		Flatness Aplatissement	
		Max 3.0mm Projection	
Customer Client		Date	
Drawn By Dessiné Par BoxCad: Annie		Date 04/03/2015	
Material Matière 16 Ga H.R.P. & O. (1.4mm)			
Color Couleur Iron Grey RAL7011		Finish Fini Rough Textured	
Description 6500 MXB 600mm x 500mm Bottom			Detail Rev.
Part Number Numéro Pièce 6500MXU160605BT		Rev. 0	3 3

Qty	Part Number	Rev	Description
1	STK-P-03810R	0	Powder Paint (Iron Grey / Rough Textured)
6	STK-Q-06001	0	Mtrx - Gland Plate M6 Plastic Thumb Nut
2	STK-Q-16055	1	M6 x 18mm Stud (No Paint Cap Required)
3	6500MXU160605GP100-P	0	6500 MXB 600mm Gland Plate Part (100mm)
6	STK-Q-16031	0	M6 x 10mm Stud (No Paint Cap Required)
1	6500MXU160605BTGPG	0	6500 MXB 600mm x 500mm Bottom Gland Plate Gasket
1	6500MXU160605BTG	0	6500 MXB 600mm x 500mm Bottom Gasket
1	6500MXU160605BT-P	0	6500 MXB 600mm x 500mm Bottom Part
Parts List			

This drawing is confidential and must not be reproduced or used without the consent of EXM

Ce dessin est confidentiel et ne doit pas être reproduit ou utilisé sans le consentement de EXM

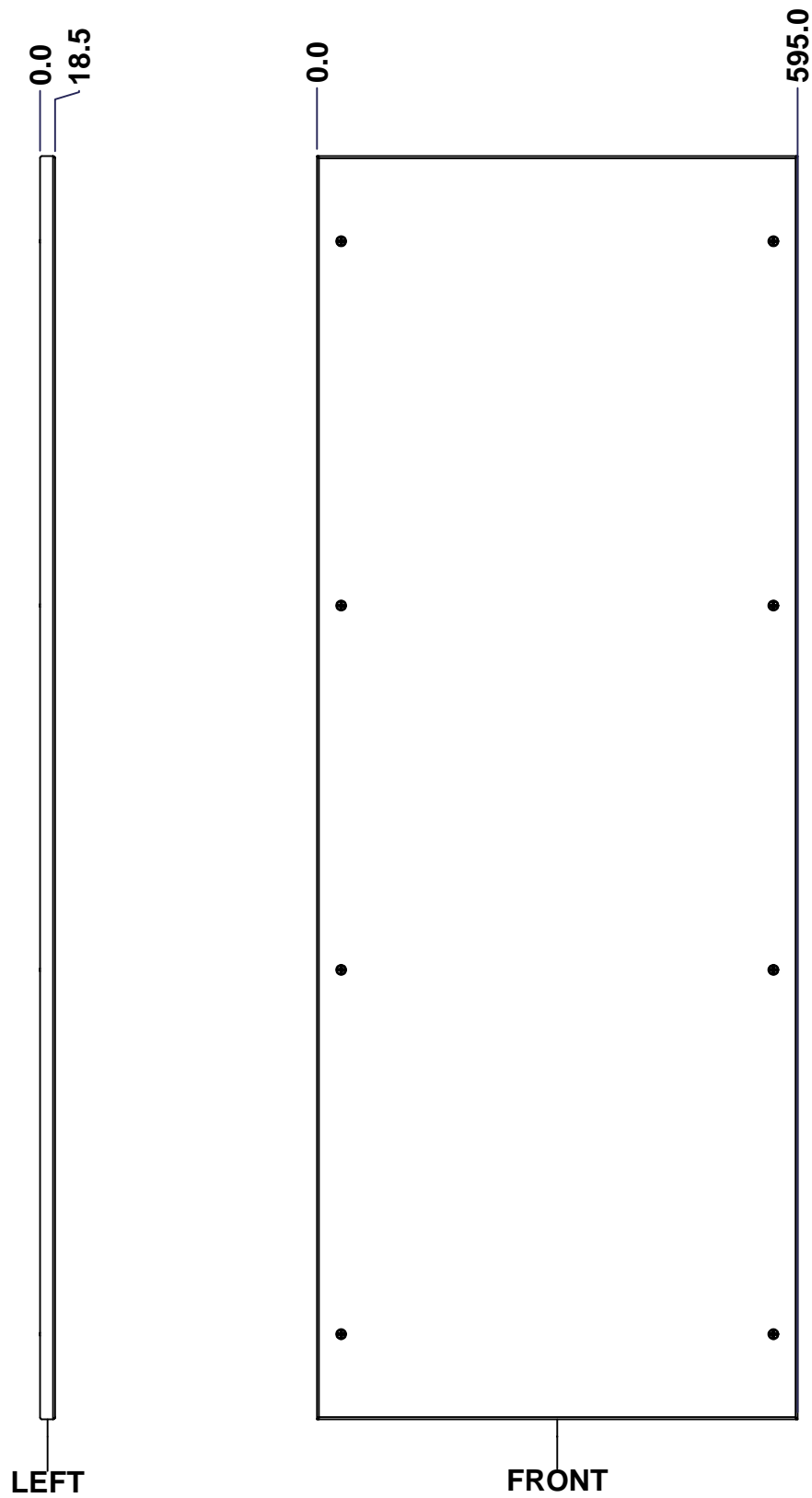
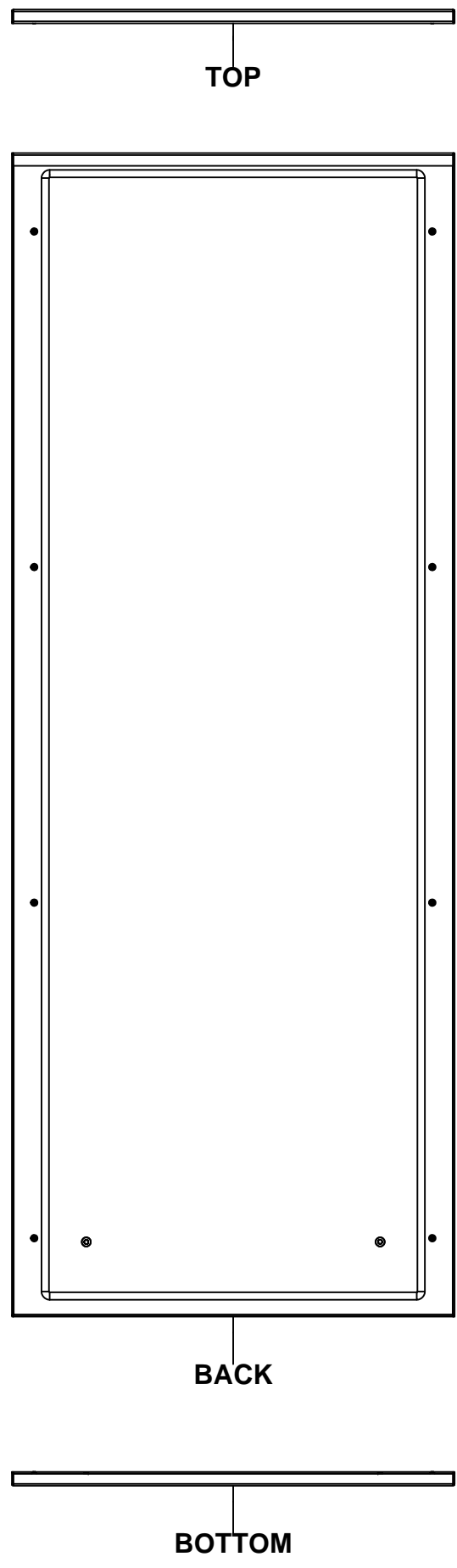

No.	Revisions	Date	By/Par

Isometric View

<p>Tél: (450) 979-4373 Fax: (450) 979-4626 www.exmweb.com</p>		Flatness Aplatissement	
		Max 3.0mm	
Customer Client		Projection	
Date			
Drawn By Dessiné Par		Date	
BoxCad: Annie		04/03/2015	
Material Matière		14 Ga H.R.P. & O. (1.7mm)	
Color Couleur		Finish Fin	
Light Grey RAL7035		Rough Textured	
Description		Detail Rev.	
6500 MXR 1600mm x 600mm Back			
Part Number Numéro Pièce		Rev.	
6500MXU160605B		0	
		1	
		3	

SEE BILL OF MATERIAL ON LAST PAGE

This drawing is confidential and must not be reproduced or used without the consent of EXM

Ce dessin est confidentiel et ne doit pas être reproduit ou utilisé sans le consentement de EXM

STANDARD FEATURES ARE NOT LISTED IN THIS HOLE TABLE			
HOLE TABLE - FRONT VIEW (CUSTOM FEATURE ONLY)			
CUT-OUT	XDIM	YDIM	DESCRIPTION
1	100.0	100.0	GND STUD M6 x 16mm (Inside)
2	495.0	100.0	GND STUD M6 x 16mm (Inside)

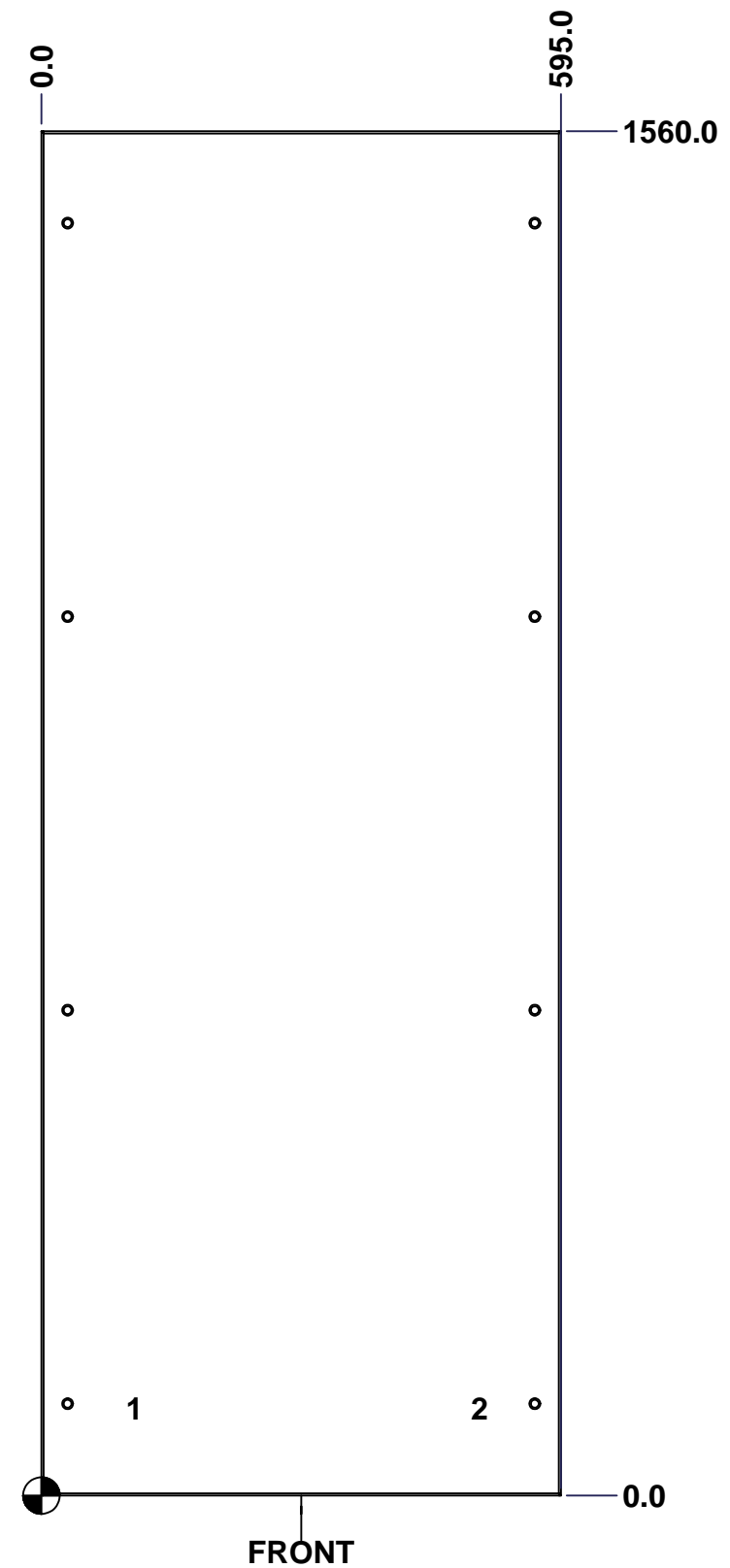



	Description	Status
	6500 MXR 1600mm x 600mm Back	(NULL)
	Part Number Numéro Pièce	Rev.
	6500MXU160605B	0
		2
		3

This drawing is confidential and must not be reproduced or used without the consent of EXM

Ce dessin est confidentiel et ne doit pas être reproduit ou utilisé sans le consentement de EXM

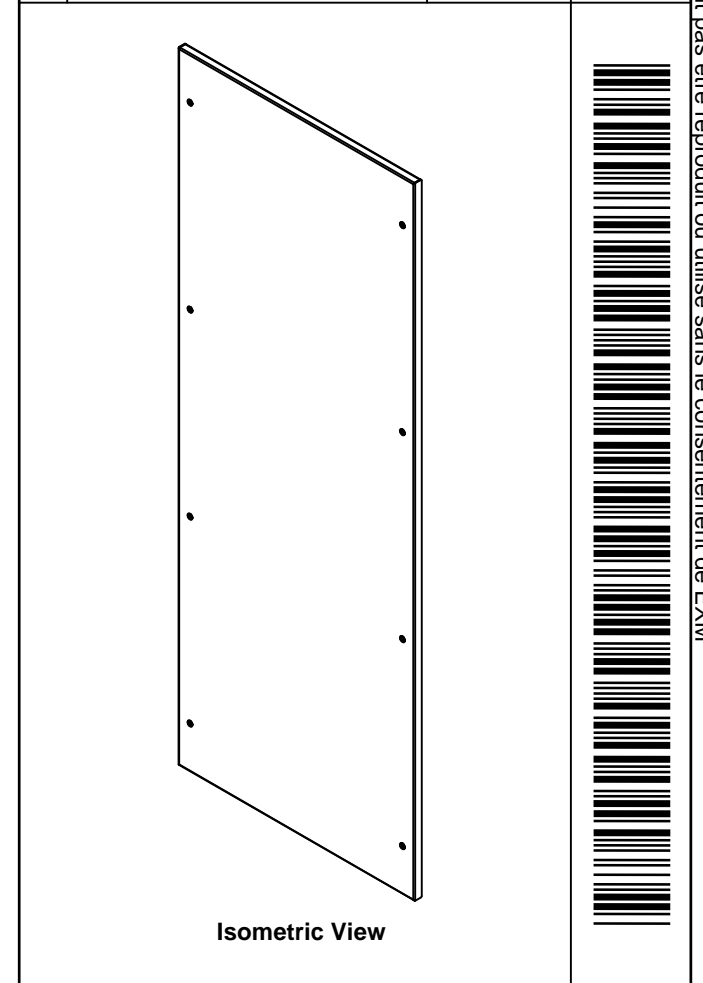
No.	Revisions	Date	By/Par

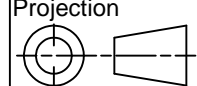

 Tél: (450) 979-4373 Fax: (450) 979-4626 www.exmweb.com		Flatness Aplatissement Max 3.0mm Projection 	
Customer Client		Date	
Drawn By / Dessiné Par: BoxCad: Annie		Date: 04/03/2015	
Material / Matière: 14 Ga H.R.P. & O. (1.7mm)			
Color / Couleur: Light Grey RAL7035		Finish / Fini: Rough Textured	
Description: 6500 MXR 1600mm x 600mm Back			Detail Rev.
Part Number / Numéro Pièce: 6500MXU160605B			Rev. 3

Qty	Part Number	Rev	Description
1	STK-P-03820R	0	Powder Paint (Light Grey / Rough Textured)
8	STK-Q-03072	2	M6 x 17mm Phillips Flat Head Screw
2	STK-Q-16080	0.1.1	M6 x 16mm Ground Stud
1	6500MXU160605BG	0	6500 MXR 1600mm x 600mm Back Gasket
1	6500MXU160605B-P	0	6500 MXR 1600mm x 600mm Back Part
Parts List			

This drawing is confidential and must not be reproduced or used without the consent of EXM

Ce dessin est confidentiel et ne doit pas être reproduit ou utilisé sans le consentement de EXM

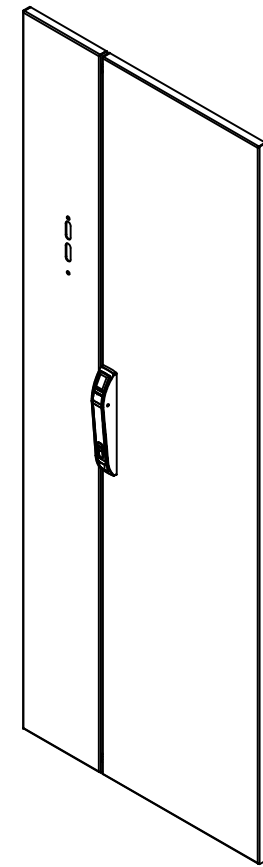
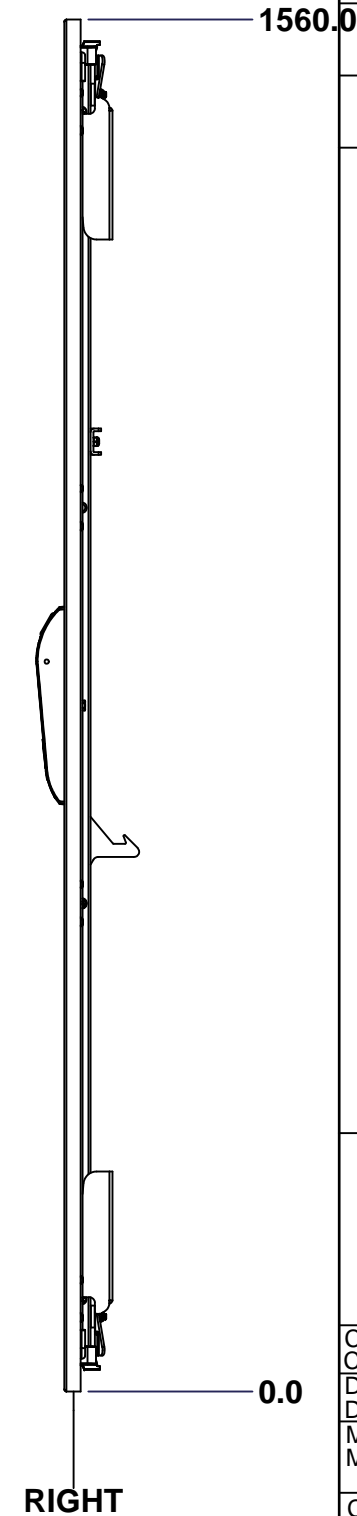
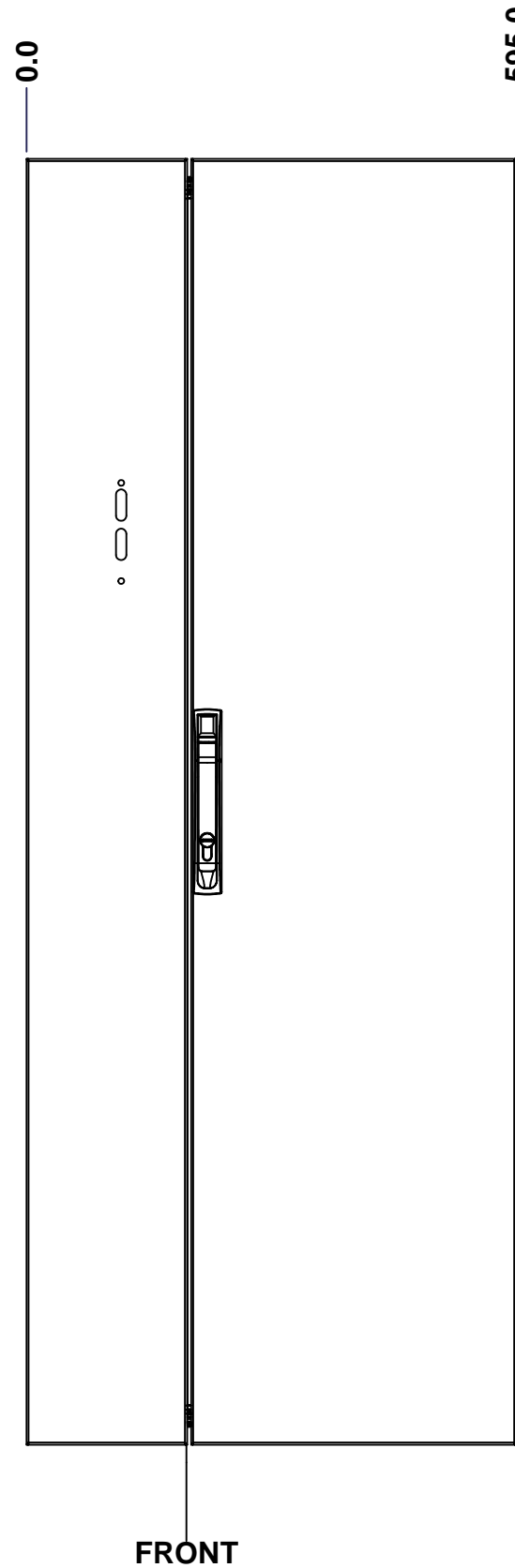
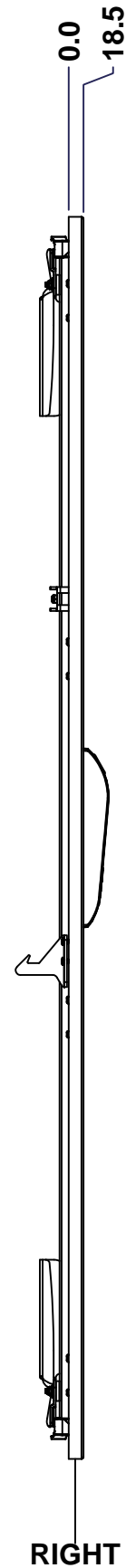
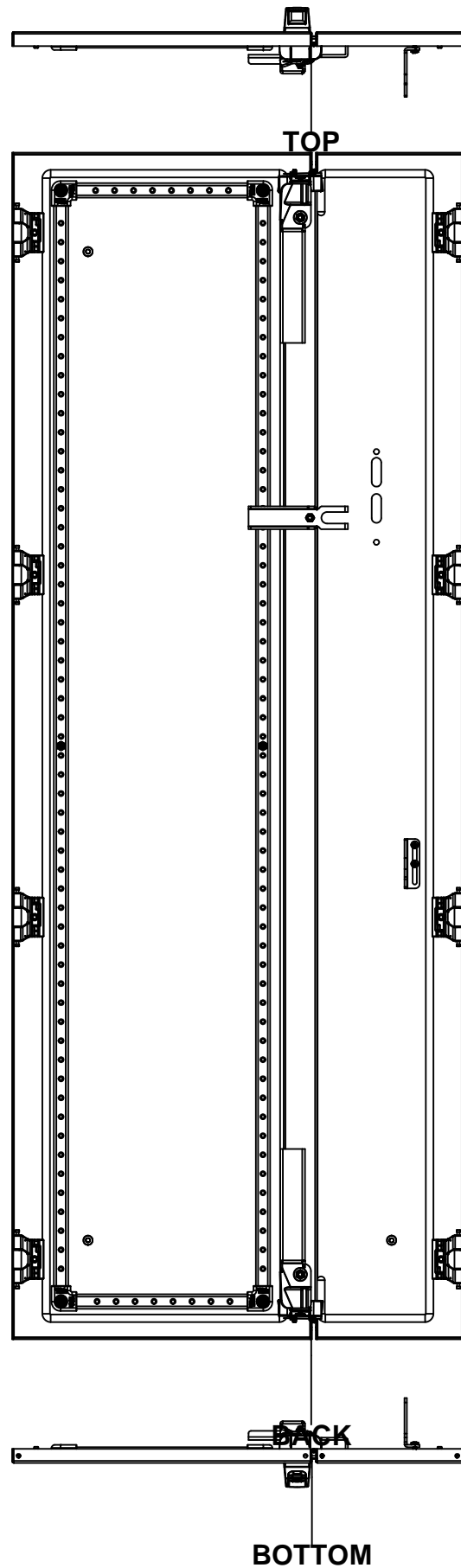

Isometric View



No.	Revisions	Date	By/Par

		Tél: (450) 979-4373 Fax: (450) 979-4626 www.exmweb.com		Flatness Aplatissement Max 3.0mm
Customer Client		Date		Projection
Drawn By Dessiné Par BoxCad: Annie		Date 04/03/2015		Material Matière 14 Ga H.R.P. & O. (1.7mm)
Color Couleur Light Grey RAL7035		Finish Fini Rough Textured		Description 6500 MXDU 1600mm x 600mm Front
Part Number Numéro Pièce 6500MXU160605F		Rev. 0		Detail Rev. 1 / 3

SEE BILL OF MATERIAL ON LAST PAGE

This drawing is confidential and must not be reproduced or used without the consent of EXM

Ce dessin est confidentiel et ne doit pas être reproduit ou utilisé sans le consentement de EXM

STANDARD FEATURES ARE NOT LISTED IN THIS HOLE TABLE

HOLE TABLE - FRONT VIEW (CUSTOM FEATURE ONLY)

CUT-OUT	XDIM	YDIM	DESCRIPTION
1	100.0	130.0	GND STUD M6 x 16mm (Inside)
2	495.0	130.0	GND STUD M6 x 16mm (Inside)
3	495.0	1430.0	GND STUD M6 x 16mm (Inside)
4	264.5	49.5	STIFF. STUD M6 x 18mm (Inside)
5	264.5	780.0	STIFF. STUD M6 x 18mm (Inside)
6	264.5	1510.5	STIFF. STUD M6 x 18mm (Inside)
7	530.5	49.5	STIFF. STUD M6 x 18mm (Inside)
8	530.5	780.0	STIFF. STUD M6 x 18mm (Inside)
9	530.5	1510.5	STIFF. STUD M6 x 18mm (Inside)
10	219.5	155.0	CLOSING BAR GUIDE (Inside)
11	219.5	1405.0	CLOSING BAR GUIDE (Inside)
12	219.5	605.0	CLOSING BAR GUIDE (Inside)
13	219.5	955.0	CLOSING BAR GUIDE (Inside)

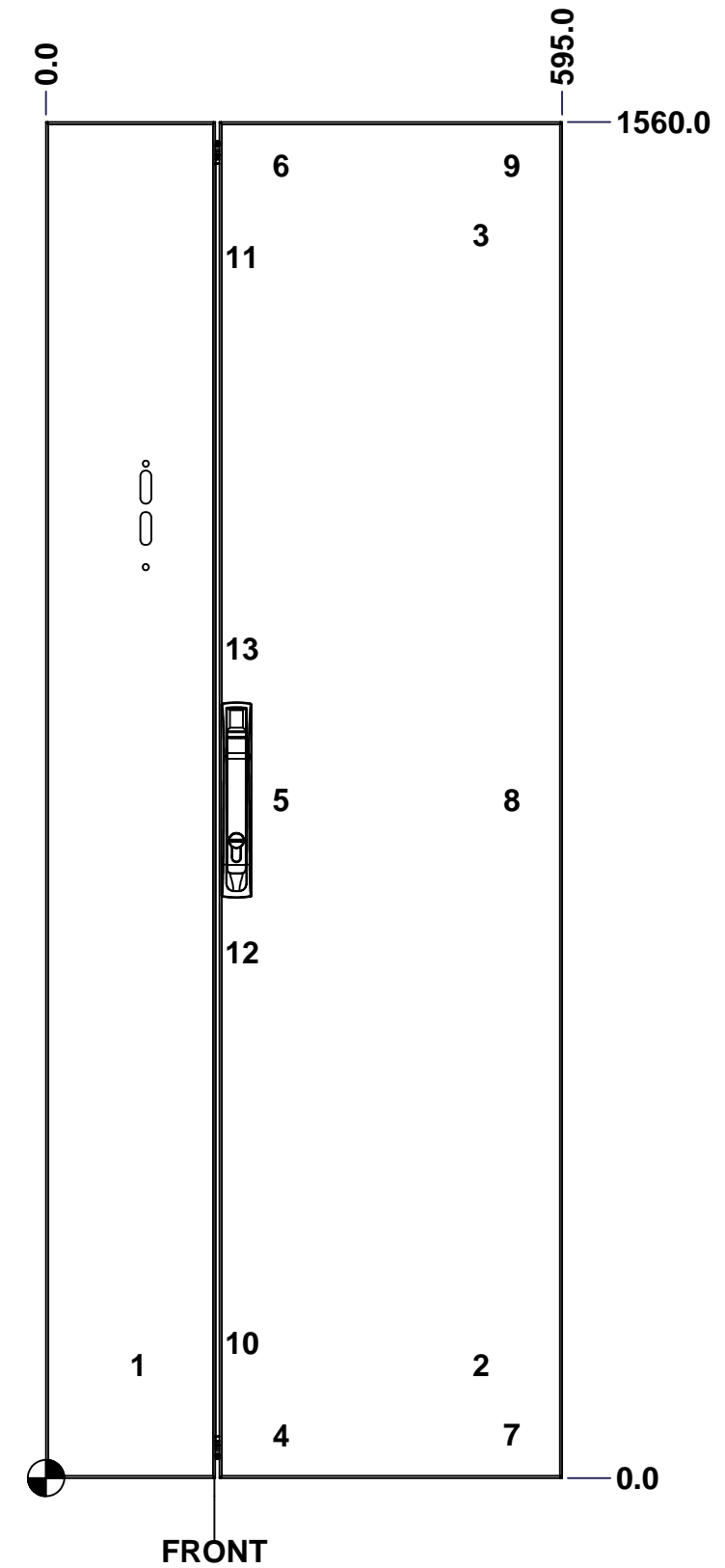

	Description	Status	
	6500 MXDU 1600mm x 600mm Front	(NULL)	
	Part Number Numéro Pièce	Rev.	
	6500MXU160605F	0	2 3

This drawing is confidential and must not be reproduced or used without the consent of EXM

Ce dessin est confidentiel et ne doit pas être reproduit ou utilisé sans le consentement de EXM

No.	Revisions	Date	By/Par

1	STK-P-03820R	0	Powder Paint (Light Grey / Rough Textured)
1	STK-Q-46650	3	6500 MXDU Disconnect Hook
1	STK-Q-45746-16	1	6500 MXD - Lock Door Closing Bar
2	STK-Q-05020	5	M5 x 8mm Thread Rolling Screw
1	6500MXU160605FG	0	6500 MXDU 1600mm x 600mm Front Gasket
1	STK-Q-07220	0	M6 Nylon Insert Lock Nut
1	STK-Q-46750	4	6500 MXDU Disconnect Defeater
1	STK-K-10102	0	6500MX - Lock Handle Kit for Flange Door - Right
1	STK-K-10101	0	6500MX - Lock Handle Kit for Flange Door - Left
1	STK-Q-16030	0	Stud M6 x 10mm
2	STK-Q-16050	0	Stud M6 x 18mm
1	STK-K-06811-27	1	6500 MX - Hinge Assy
1	STK-K-06811-26	1	6500 MX - Hinge Assy
1	STK-K-06811-31	1	6500 MX - Hinge Assy
1	STK-K-06811-30	1	6500 MX - Hinge Assy
4	STK-Q-03061	2	M6 x 6.5mm Stainless Steel Phillips Flat Head Screw
4	STK-Q-70483	1	Flange Door Bracket
4	STK-Q-05010	0	M5 x 12mm Flat Head Thread Rolling Screw
1	STK-Q-74700-2	5	6500 MX - Flange Door Sealing Block
1	STK-Q-74700-1	5	6500 MX - Flange Door Sealing Block
1	STK-K-06811-32	1	6500 MX - Hinge Assy
1	STK-K-06811-29	1	6500 MX - Hinge Assy
1	6500MXU160605F1-P	0	6500 MXDU 1600mm x 600mm Front Part
4	STK-Q-78022	0	Mtrx Closing Bar Slider
1	STK-Q-45729-16	2	6500 MXD - Lock Door Top Closing Bar
1	STK-A-886PHD-S-1_Left	4	Euroform Pull Handle Kit
6	STK-Q-16055	1	M6 x 18mm Stud (No Paint Cap Required)
1	STK-K-06811-25	1	6500 MX - Hinge Assy
1	STK-K-06811-28	1	6500 MX - Hinge Assy
8	STK-Q-33105	4	5412 ESBU Buttable Hinge (Cover Part)
3	STK-Q-16080	0.1.1	M6 x 16mm Ground Stud
1	6500MXU160605DS1	5	6500 MX 1600mm x 600mm Door Stiffener
1	6500MXU160605F1G	0	6500 MXDU 1600mm x 600mm Front Gasket
1	6500MXU160605F-P	0	6500 MXDU 1600mm x 600mm Front Part
Qty	Part Number	Rev.	Description

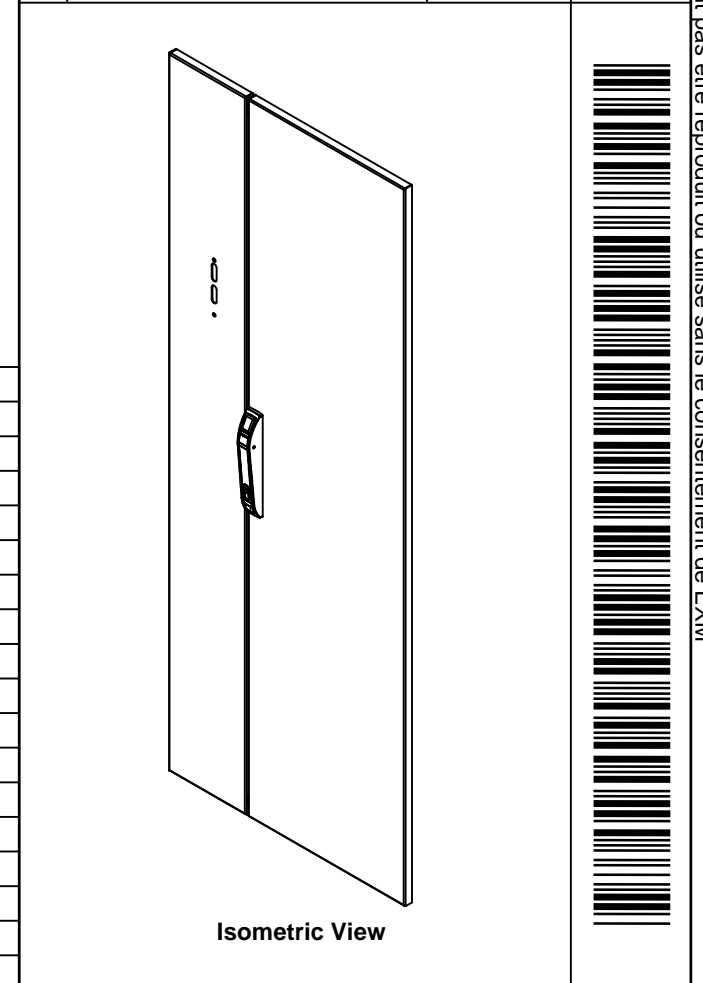

Tél: (450) 979-4373 Fax: (450) 979-4626 www.exmweb.com		Flatness Aplatissement Max 3.0mm Projection
Customer Client	Date	
Drawn By Dessiné Par	BoxCad: Annie	Date 04/03/2015
Material Matière	14 Ga H.R.P. & O. (1.7mm)	
Color Couleur	Light Grey RAL7035	Finish Fini Rough Textured
Description	6500 MXDU 1600mm x 600mm Front	
Part Number Numéro Pièce	Rev. 0	3
6500MXU160605F		

Parts List

This drawing is confidential and must not be reproduced or used without the consent of EXM

Ce dessin est confidentiel et ne doit pas être reproduit ou utilisé sans le consentement de EXM

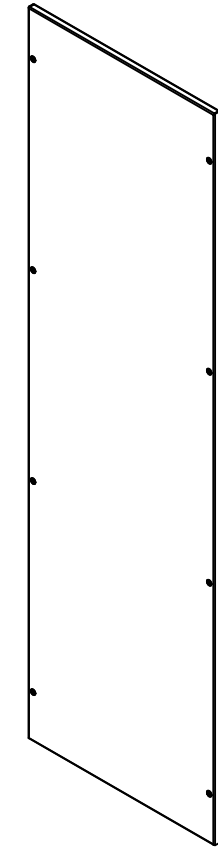
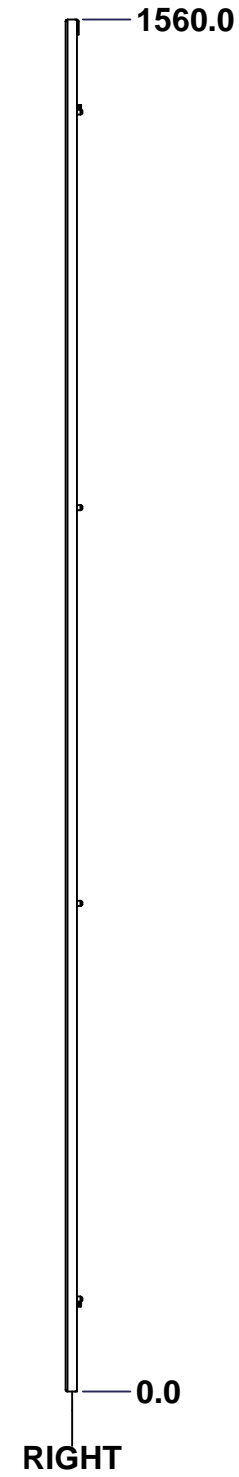
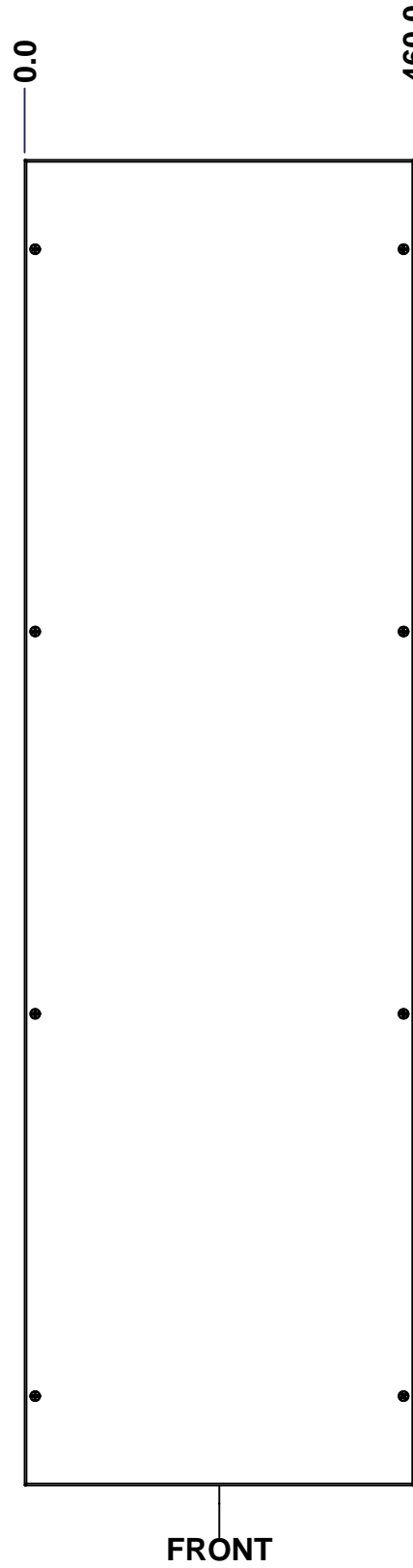
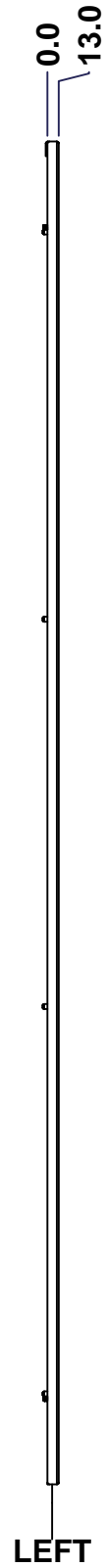
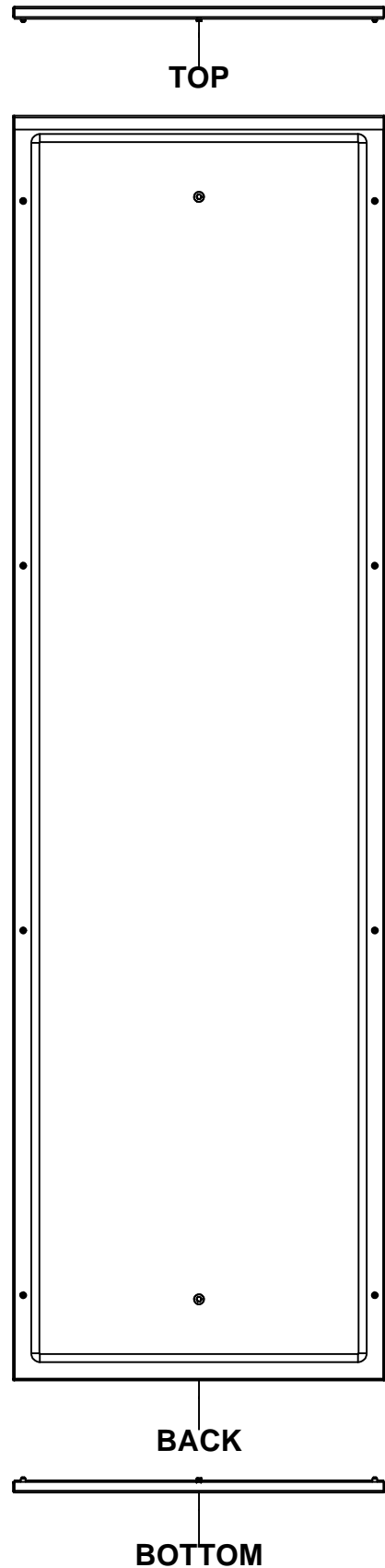

Isometric View

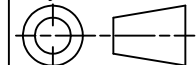

No.	Revisions	Date	By/Par

 Tél: (450) 979-4373 Fax: (450) 979-4626 www.exmweb.com		Flatness Aplatissement Max 3.0mm Projection 
Customer Client	Date	
Drawn By Dessiné Par	BoxCad: Annie	Date 04/03/2015
Material Matière	16 Ga H.R.P. & O. (1.4mm)	
Color Couleur	Light Grey RAL7035	Finish Fin Rough Textured
Description 6500 MXC 1600mm x 500mm Left		Detail Rev.
Part Number Numéro Pièce	6500MXU160605L	Rev. 1 0

SEE BILL OF MATERIAL ON LAST PAGE

This drawing is confidential and must not be reproduced or used without the consent of EXM

Ce dessin est confidentiel et ne doit pas être reproduit ou utilisé sans le consentement de EXM

STANDARD FEATURES ARE NOT LISTED IN THIS HOLE TABLE			
HOLE TABLE - FRONT VIEW (CUSTOM FEATURE ONLY)			
CUT-OUT	XDIM	YDIM	DESCRIPTION
1	230.0	100.0	GND STUD M6 x 16mm (Inside)
2	230.0	1460.0	GND STUD M6 x 16mm (Inside)

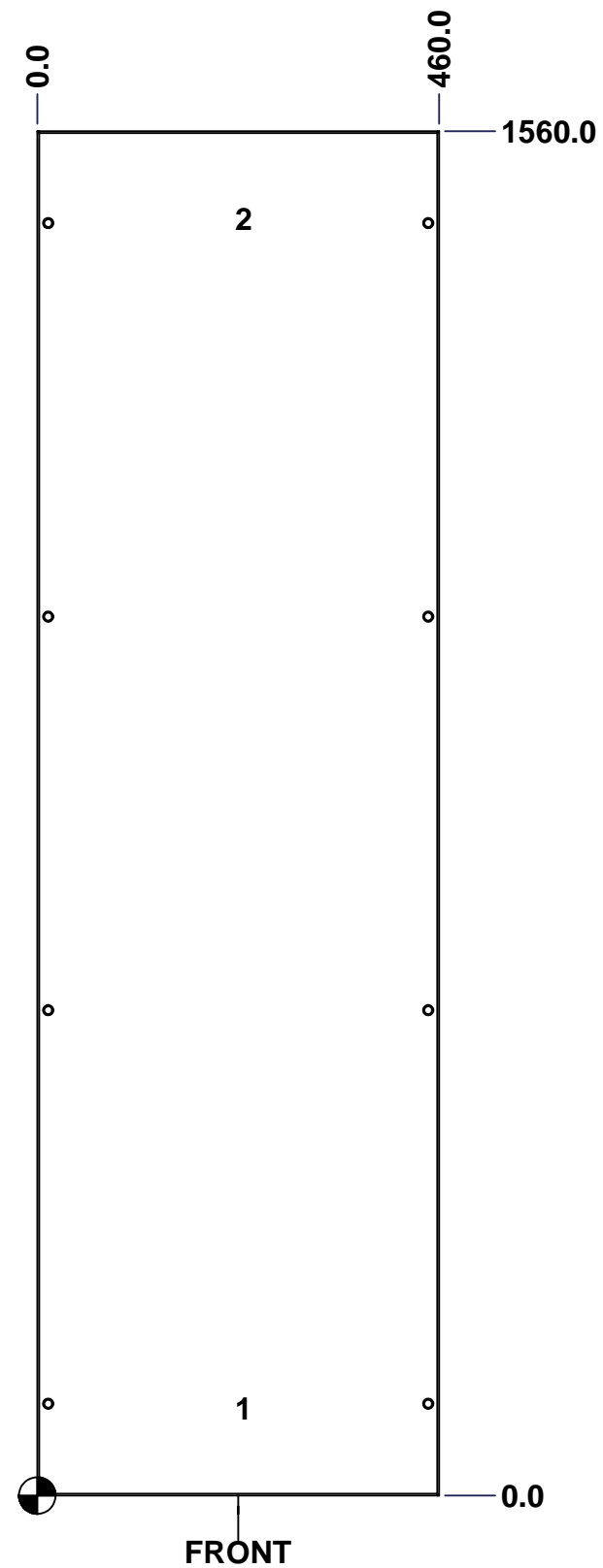

	Description	Status
	6500 MXC 1600mm x 500mm Left	(NULL)
	Part Number Numéro Pièce	Rev.
	6500MXU160605L	0
		2
		3

This drawing is confidential and must not be reproduced or used without the consent of EXM

Ce dessin est confidentiel et ne doit pas être reproduit ou utilisé sans le consentement de EXM

No.	Revisions	Date	By/Par

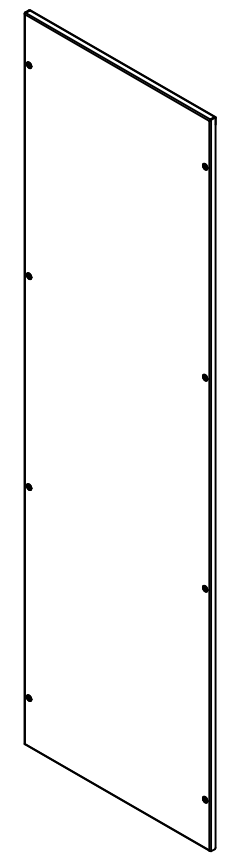

Isometric View

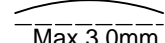
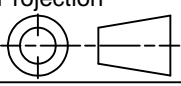

		Tél: (450) 979-4373 Fax: (450) 979-4626 www.exmweb.com		Flatness Aplatissement  Max 3.0mm			
Customer Client		Date		Projection 			
Drawn By Dessiné Par BoxCad: Annie		Date 04/03/2015					
Material Matière 16 Ga H.R.P. & O. (1.4mm)							
Color Couleur Light Grey RAL7035		Finish Fini Rough Textured					
Description 6500 MXC 1600mm x 500mm Left				Detail Rev.			
Part Number Numéro Pièce 6500MXU160605L				Rev. 3			
				<table border="1" style="width: 100%; border-collapse: collapse;"> <tr> <td style="width: 50%; text-align: center;">0</td> <td style="width: 50%; text-align: center;">3</td> </tr> </table>		0	3
0	3						

Qty	Part Number	Rev	Description
1	STK-P-03820R	0	Powder Paint (Light Grey / Rough Textured)
8	STK-Q-03072	2	M6 x 17mm Phillips Flat Head Screw
2	STK-Q-16080	0.1.1	M6 x 16mm Ground Stud
1	6500MXU160605LG	0	6500 MXC 1600mm x 500mm Left Gasket
1	6500MXU160605L-P	0	6500 MXC 1600mm x 500mm Left Part
Parts List			

This drawing is confidential and must not be reproduced or used without the consent of EXM

Ce dessin est confidentiel et ne doit pas être reproduit ou utilisé sans le consentement de EXM

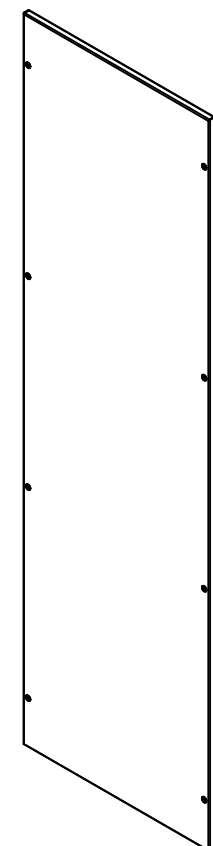
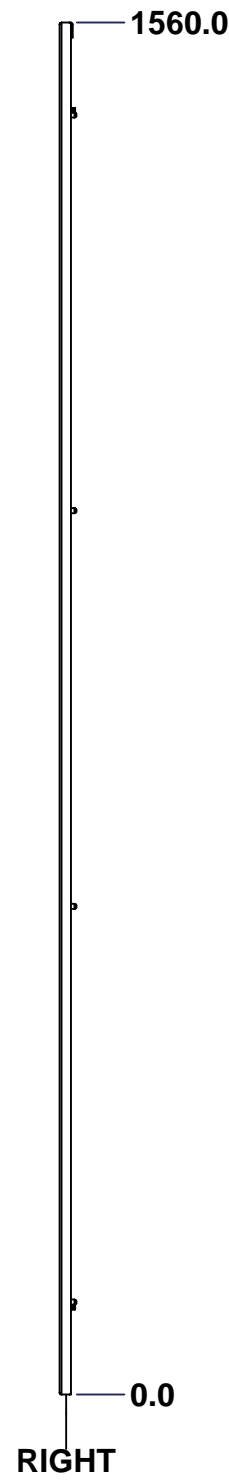
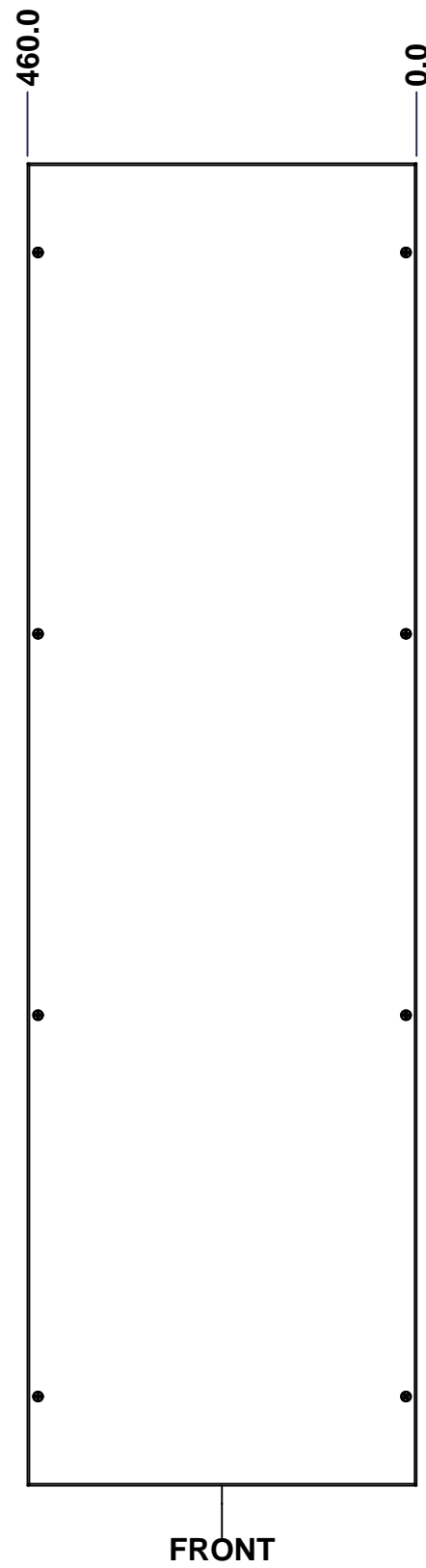
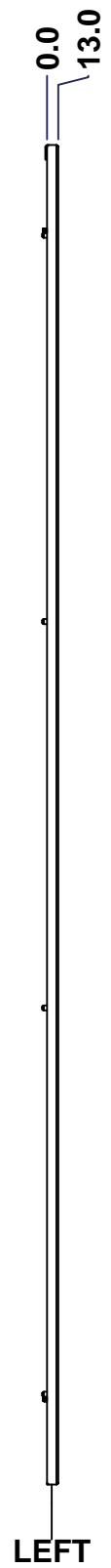
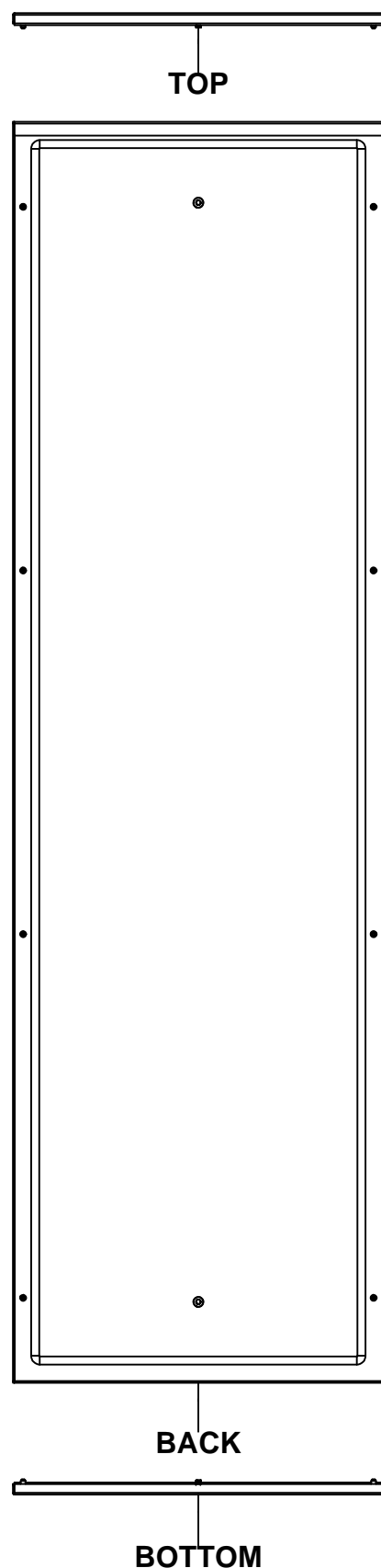

Isometric View



No.	Revisions	Date	By/Par

		Flatness Aplatissement Max 3.0mm Projection 	
Tél: (450) 979-4373 Fax: (450) 979-4626 www.exmweb.com		Customer Client Date	
Drawn By Dessiné Par BoxCad: Annie		Date 04/03/2015	
Material Matière 16 Ga H.R.P. & O. (1.4mm)		Color Couleur Light Grey RAL7035	
Finish Fini Rough Textured		Description 6500 MXC 1600mm x 500mm Right	
Part Number Numéro Pièce 6500MXU160605R		Detail Rev. Rev. 1 0 3	

SEE BILL OF MATERIAL ON LAST PAGE

This drawing is confidential and must not be reproduced or used without the consent of EXM

Ce dessin est confidentiel et ne doit pas être reproduit ou utilisé sans le consentement de EXM

STANDARD FEATURES ARE NOT LISTED IN THIS HOLE TABLE			
HOLE TABLE - FRONT VIEW (CUSTOM FEATURE ONLY)			
CUT-OUT	XDIM	YDIM	DESCRIPTION
1	230.0	100.0	GND STUD M6 x 16mm (Inside)
2	230.0	1460.0	GND STUD M6 x 16mm (Inside)

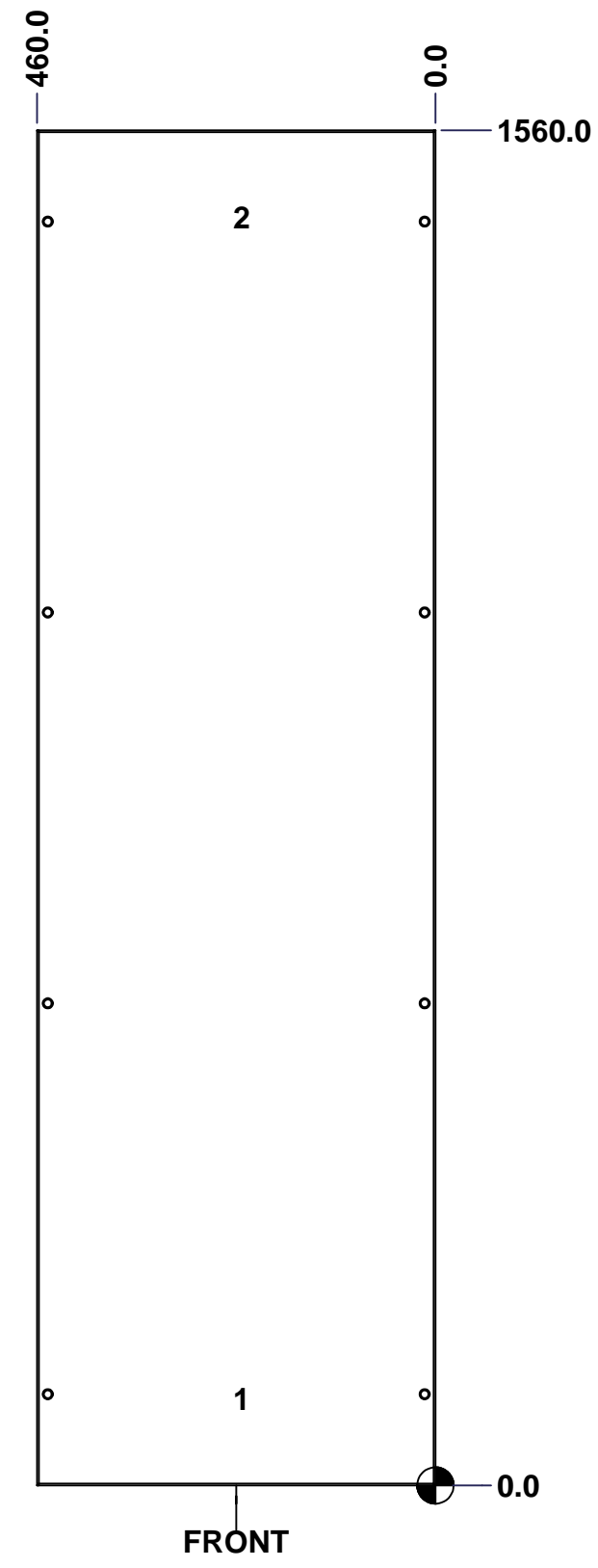



	Description	Status	
	6500 MXC 1600mm x 500mm Right	(NULL)	
	Part Number Numéro Pièce	Rev.	
	6500MXU160605R	0	2 3

This drawing is confidential and must not be reproduced or used without the consent of EXM

Ce dessin est confidentiel et ne doit pas être reproduit ou utilisé sans le consentement de EXM

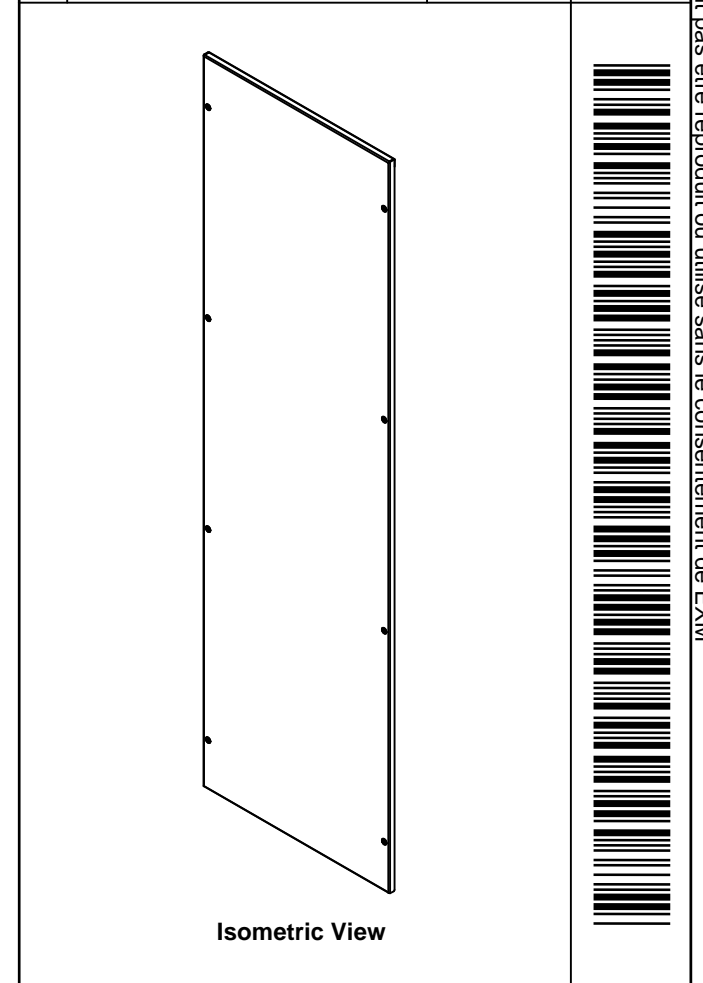
No.	Revisions	Date	By/Par

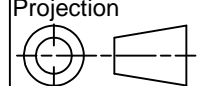

 Tél: (450) 979-4373 Fax: (450) 979-4626 www.exmweb.com		Flatness Aplatissement Max 3.0mm Projection 
Customer Client	Date	
Drawn By Dessiné Par	BoxCad: Annie	Date 04/03/2015
Material Matière	16 Ga H.R.P. & O. (1.4mm)	
Color Couleur	Light Grey RAL7035	Finish Fini Rough Textured
Description	Detail Rev.	
6500 MXC 1600mm x 500mm Right		
Part Number Numéro Pièce	Rev. 3	3
6500MXU160605R		0

Qty	Part Number	Rev	Description
1	STK-P-03820R	0	Powder Paint (Light Grey / Rough Textured)
8	STK-Q-03072	2	M6 x 17mm Phillips Flat Head Screw
2	STK-Q-16080	0.1.1	M6 x 16mm Ground Stud
1	6500MXU160605RG	0	6500 MXC 1600mm x 500mm Right Gasket
1	6500MXU160605R-P	0	6500 MXC 1600mm x 500mm Right Part
Parts List			

This drawing is confidential and must not be reproduced or used without the consent of EXM

Ce dessin est confidentiel et ne doit pas être reproduit ou utilisé sans le consentement de EXM

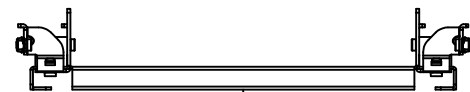

TOP

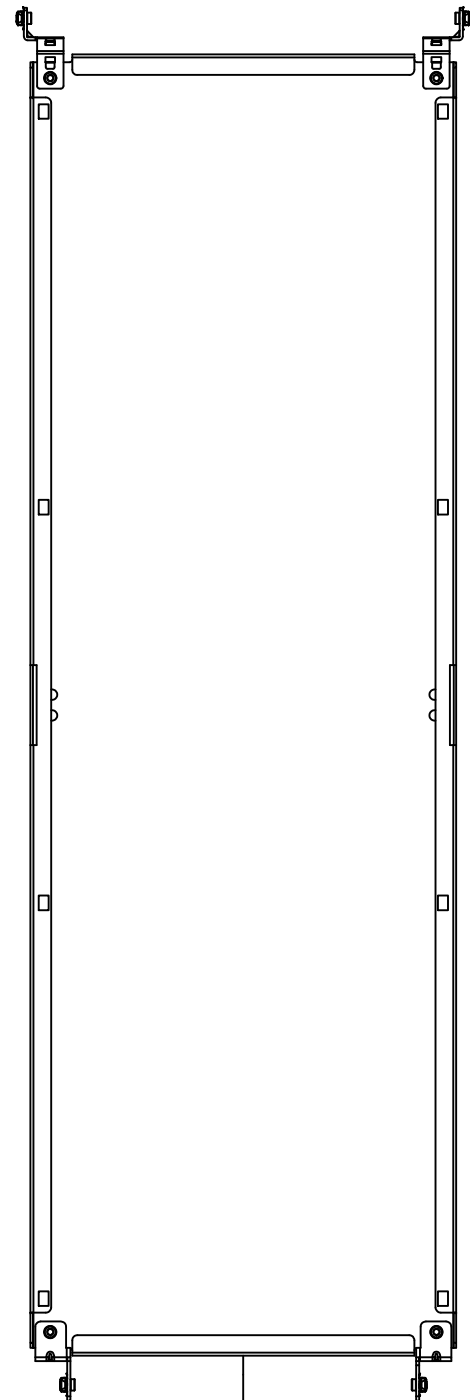

BACK



BOTTOM

0.0
26.0

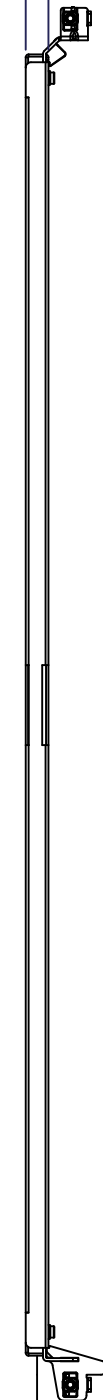

LEFT

0.0
485.0

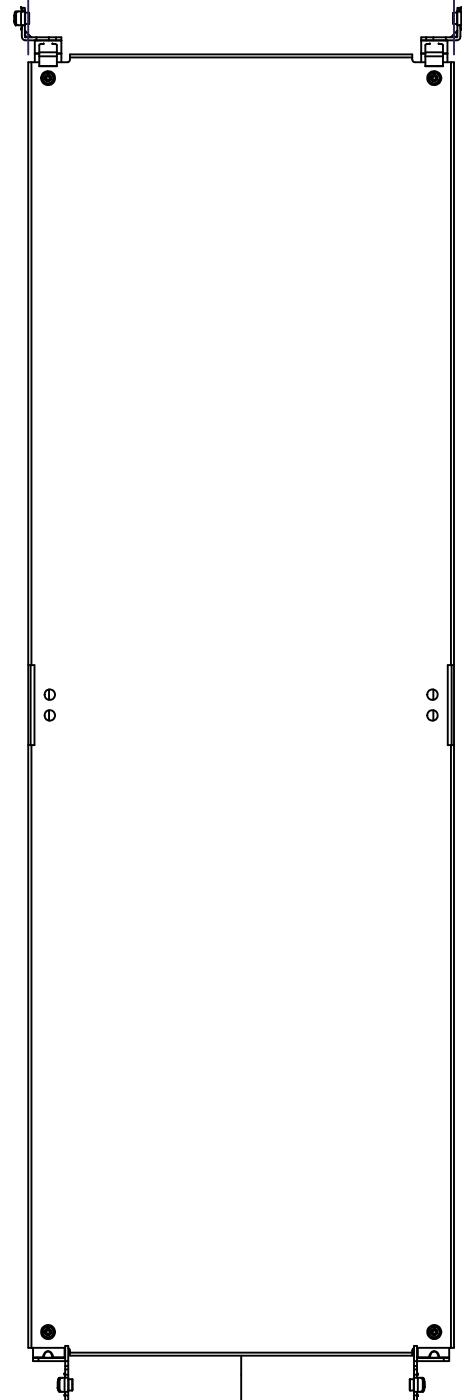

FRONT

1480.0

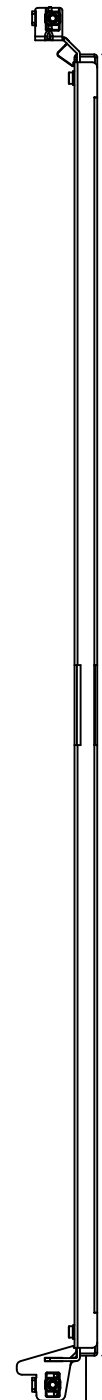

RIGHT

0.0

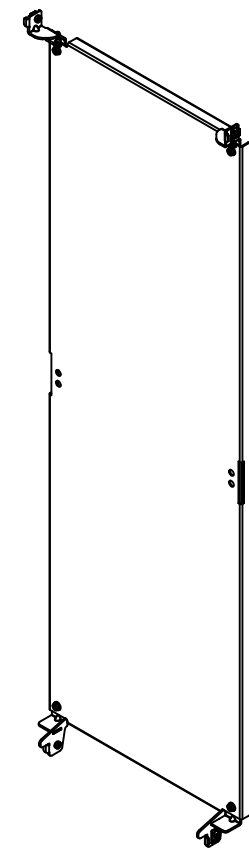

Isometric View

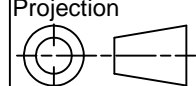

No.	Revisions	Date	By/Par

 Tél: (450) 979-4373 Fax: (450) 979-4626 www.exmweb.com		Flatness Aplatissement Max 3.0mm Projection 
Customer Client	Date	
Drawn By Dessiné Par	BoxCad: Annie	Date 04/03/2015
Material Matière	12 Ga Galvanized (2.5mm)	
Color Couleur	Unpainted	Finish Fini Unpainted
Description	Detail Rev.	
6500 MXM 1600mm x 600mm Back Inner Panel		
Part Number Numéro Pièce	Rev.	1
6500MXU160605BIP	0	3

SEE BILL OF MATERIAL ON LAST PAGE

This drawing is confidential and must not be reproduced or used without the consent of EXM

Ce dessin est confidentiel et ne doit pas être reproduit ou utilisé sans le consentement de EXM

No.	Revisions	Date	By/Par

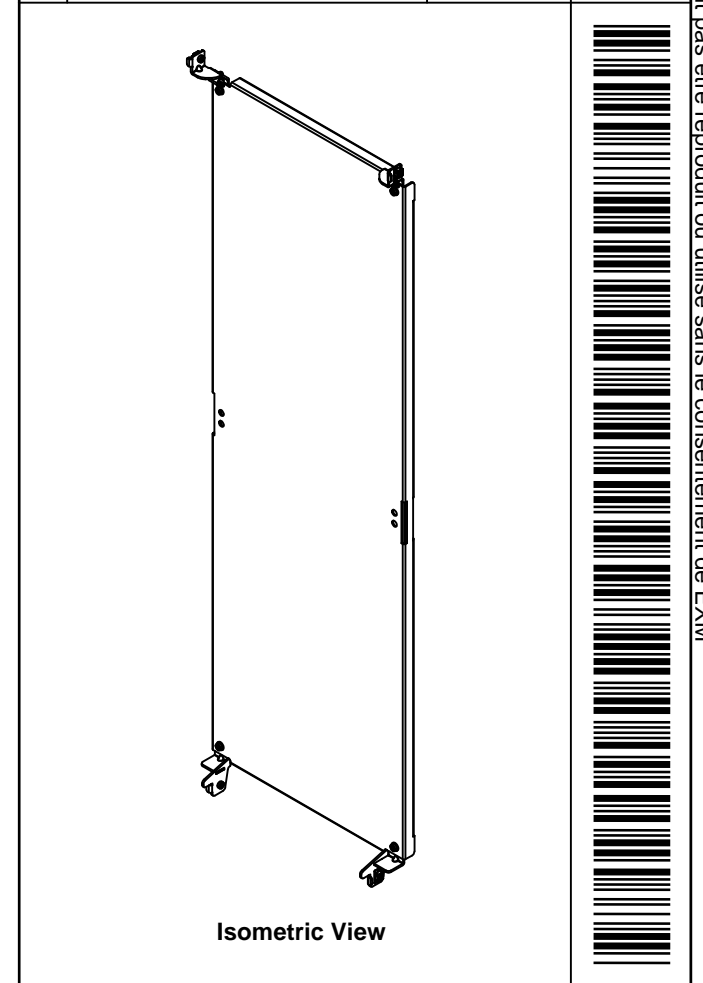

Tél: (450) 979-4373 Fax: (450) 979-4626 www.exmweb.com		Flatness Aplatissement	
		Max 3.0mm Projection	
Customer Client		Date	
Drawn By Dessiné Par BoxCad: Annie		Date 04/03/2015	
Material Matière 12 Ga Galvanized (2.5mm)			
Color Couleur Unpainted		Finish Fini Unpainted	
Description 6500 MXM 1600mm x 600mm Back Inner Panel			Detail Rev.
Part Number Numéro Pièce		Rev.	3
6500MXU160605BIP		0	3

Qty	Part Number	Rev	Description
1	STK-A-49005	0	6500MXM - Bottom Inner Panel Support Kit (Right)
1	STK-A-49000	0	6500MXM - Bottom Inner Panel Support Kit (Left)
1	STK-A-49015	0	6500MXM - Top Inner Panel Support Kit (Right)
1	STK-A-49010	0	6500MXM - Top Inner Panel Support Kit (Left)
1	6500MXU160605BIP-P	0	6500 MXM 1600mm x 600mm Back Inner Panel Part
Parts List			