

This drawing is confidential and must not be reproduced or used without the consent of EXM

Ce dessin est confidentiel et ne doit pas être reproduit ou utilisé sans le consentement de EXM

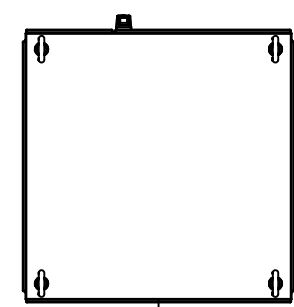

TOP

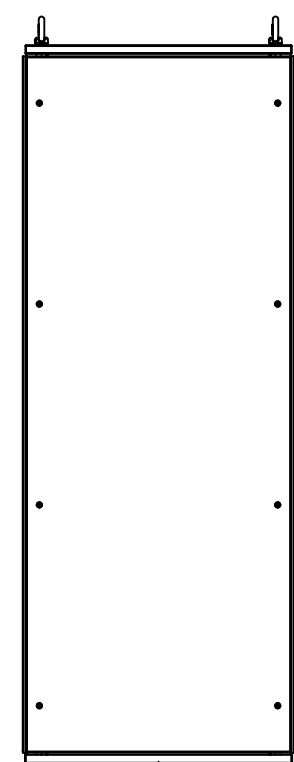

BACK

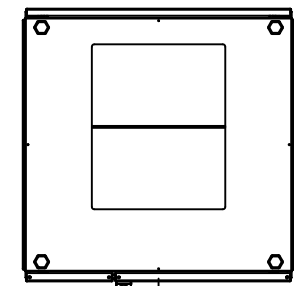

BOTTOM

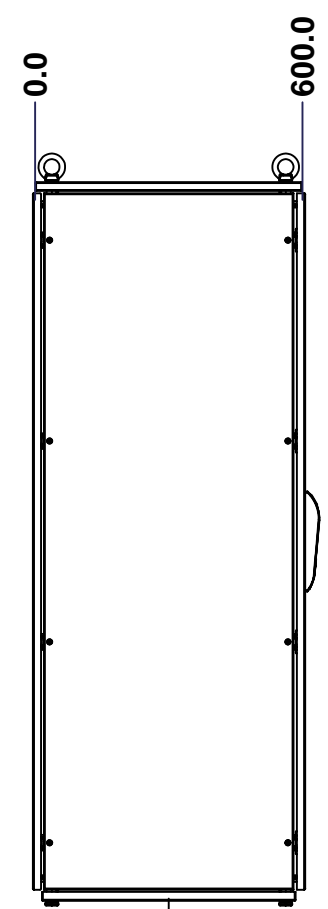

LEFT

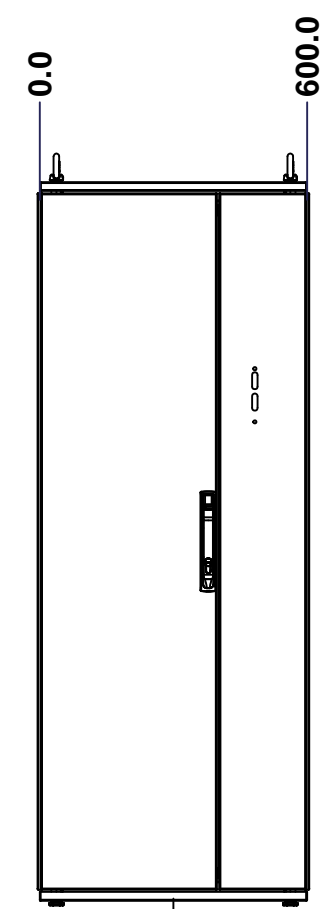

FRONT

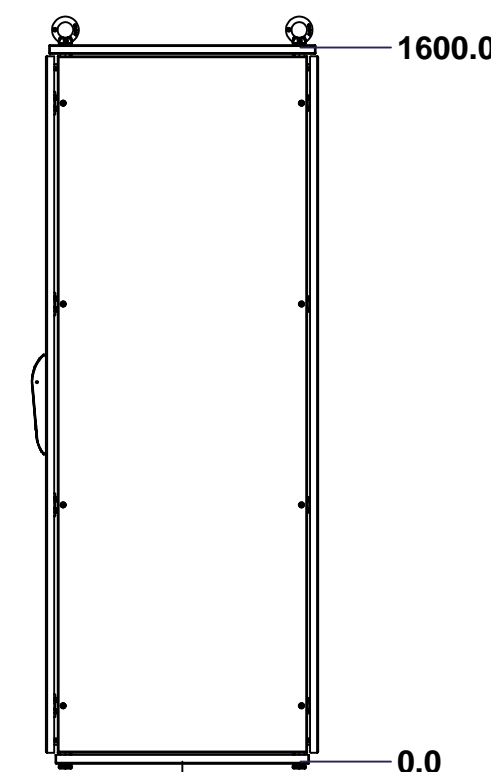

RIGHT

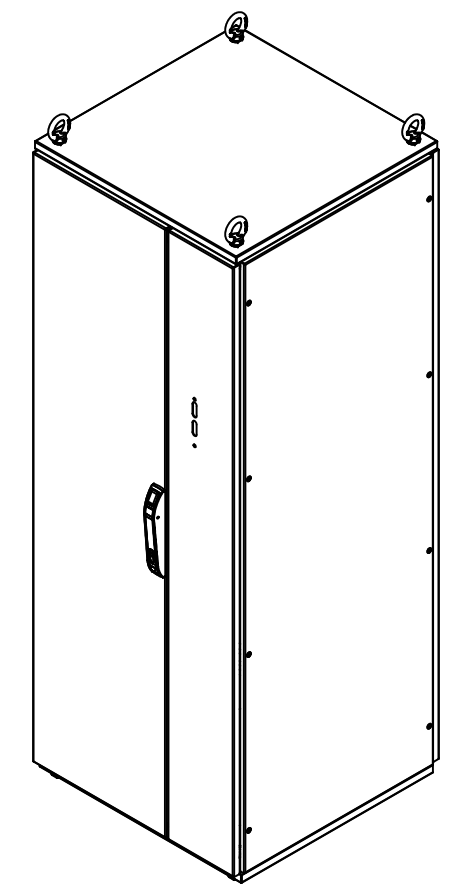

Isometric View

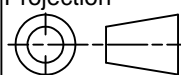

No.	Revisions	Date	By/Par

 Tél: (450) 979-4373 Fax: (450) 979-4626 <a href="http://www.exmweb.com">www.exmweb.com</a>		Flatness Aplatissement Max 3.0mm Projection 
Customer Client	Date	Date
Drawn By Dessiné Par	BoxCad: Annie	Date 04/03/2015
Material Matière	See Part List	
Color Couleur	See Part List	Finish Fini See Part List
Description	Detail Rev.	
6500MX 1600mm x 600mm x 600mm Assembly		
Part Number Numéro Pièce	Rev.	
6500MXU160606	0	1 2

SEE BILL OF MATERIAL ON LAST PAGE

This drawing is confidential and must not be reproduced or used without the consent of EXM

Ce dessin est confidentiel et ne doit pas être reproduit ou utilisé sans le consentement de EXM

No.	Revisions	Date	By/Par

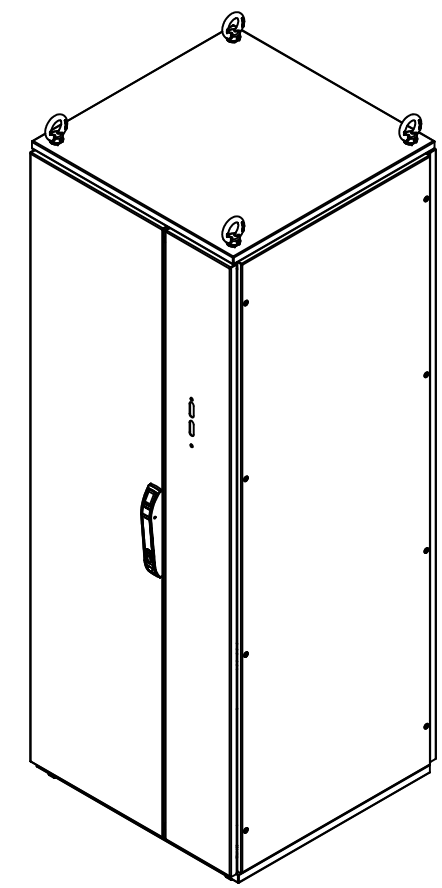

Isometric View



Tél: (450) 979-4373  
 Fax: (450) 979-4626  
[www.exmweb.com](http://www.exmweb.com)

Flatness  
Aplatissement  
Max 3.0mm  
Projection

Customer Client  
Date  
 Drawn By Dessiné Par BoxCad: Annie  
Date 04/03/2015

Material Matière  
See Part List

Color Couleur  
See Part List  
 Finish Fini  
See Part List

Description  
6500MX 1600mm x 600mm x 600mm Assembly  
 Detail Rev.

Part Number Numéro Pièce  
**6500MXU160606**  
 Rev. 2  
**0** 2

1	6500MXU160606BIP	0	6500 MXM 1600mm x 600mm Back Inner Panel
1	6500MXU160606R	0	6500 MXC 1600mm x 600mm Right
1	6500MXU160606L	0	6500 MXC 1600mm x 600mm Left
1	6500MXU160606F	0	6500 MXDU 1600mm x 600mm Front
1	6500MXU160606B	0	6500 MXR 1600mm x 600mm Back
1	6500MXU160606BT	0	6500 MXB 600mm x 600mm Bottom
1	6500MXU160606T	0	6500 MXT 600mm x 600mm Top
1	6500MXU160606FR	0	6500 MX 1600mm x 600mm x 600mm Frame
Qty	Part Number	Rev	Description
Parts List			

This drawing is confidential and must not be reproduced or used without the consent of EXM

Ce dessin est confidentiel et ne doit pas être reproduit ou utilisé sans le consentement de EXM

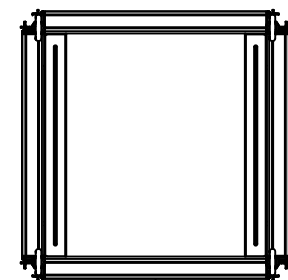

TOP

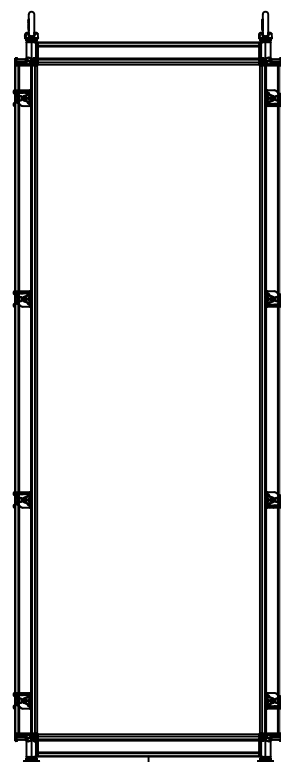

BACK

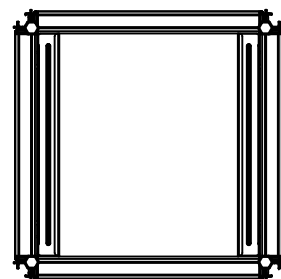

BOTTOM

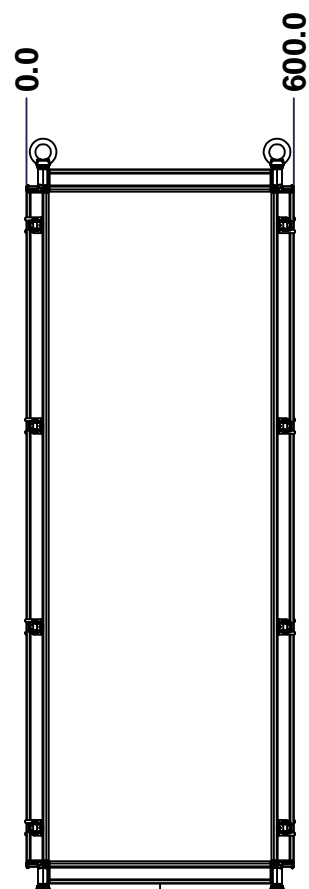

LEFT

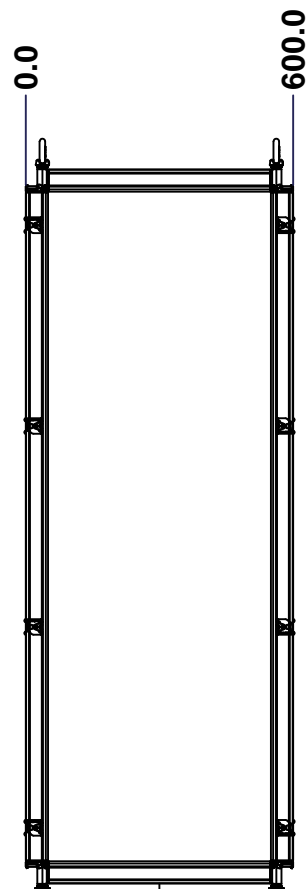

FRONT

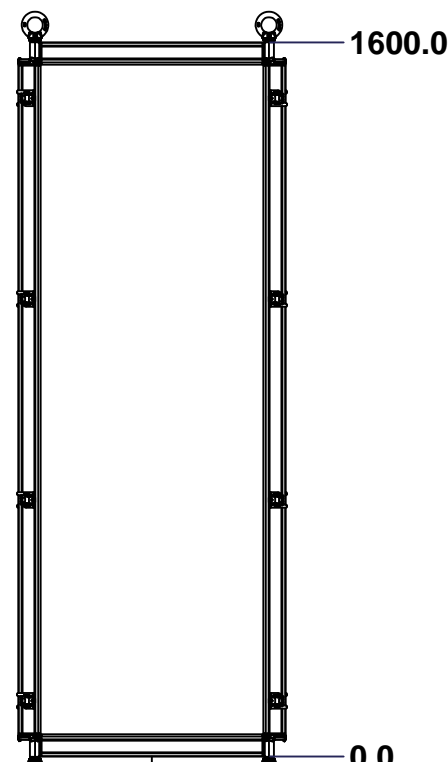

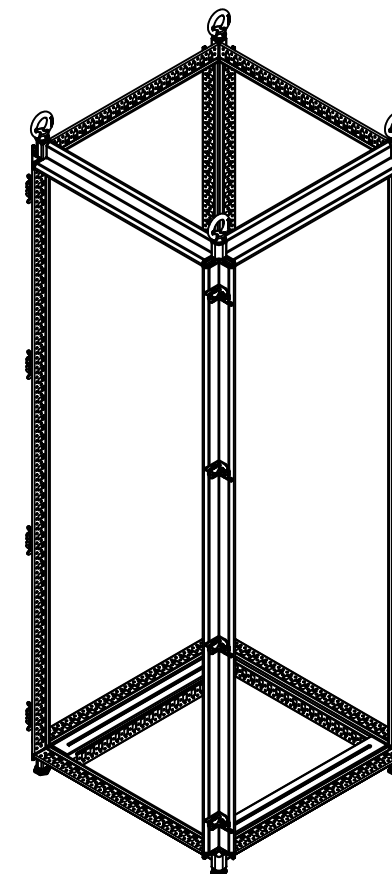

RIGHT



Isometric View



No.	Revisions	Date	By/Par

 Tél: (450) 979-4373 Fax: (450) 979-4626 <a href="http://www.exmweb.com">www.exmweb.com</a>		Flatness Aplatissement Max 3.0mm Projection 
Customer Client	Date	
Drawn By Dessiné Par	BoxCad: Annie	Date 04/03/2015
Material Matière	16 Ga Electro-Galvanized (1.4mm)	
Color Couleur	Iron Grey RAL7011	Finish Fini Rough Textured
Description	Detail Rev.	
6500 MX 1600mm x 600mm x 600mm Frame		
Part Number Numéro Pièce	Rev.	1 2
<b>6500MXU160606FR</b>	<b>0</b>	

SEE BILL OF MATERIAL ON LAST PAGE

This drawing is confidential and must not be reproduced or used without the consent of EXM

Ce dessin est confidentiel et ne doit pas être reproduit ou utilisé sans le consentement de EXM

No.	Revisions	Date	By/Par

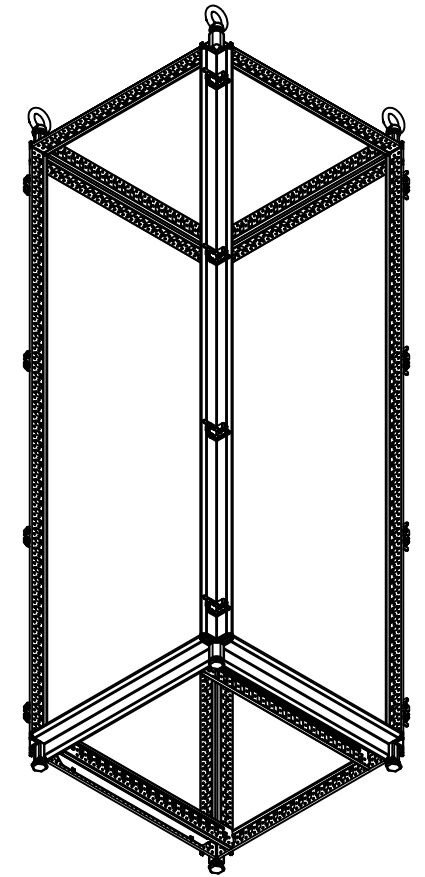

Isometric View

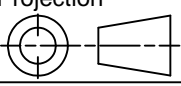

 Tél: (450) 979-4373 Fax: (450) 979-4626 <a href="http://www.exmweb.com">www.exmweb.com</a>	Flatness / Aplatissement	
	Max 3.0mm	
Projection 	Date	
	Date 04/03/2015	
Customer / Client	Date	
Drawn By / Dessiné Par	BoxCad: Annie	Date 04/03/2015
Material / Matière	16 Ga Electro-Galvanized (1.4mm)	
Color / Couleur	Iron Grey RAL7011	Finish / Fini: Rough Textured
Description	Detail Rev.	
6500 MX 1600mm x 600mm x 600mm Frame		
Part Number / Numéro Pièce	Rev.	2
<b>6500MXU160606FR</b>	<b>0</b>	<b>2</b>

Qty	Part Number	Rev	Description
1	STK-P-03810R	0	Powder Paint (Iron Grey / Rough Textured)
1	STK-Q-49060	3	6500 MXM Inner Panel Slider 600mm
1	STK-Q-49060-L	3	6500 MXM Inner Panel Slider 600mm
4	STK-Q-49500	3	M12 Eye Bolt (0.34T)
4	STK-Q-61110	0	M12 Feet Leveler
8	STK-Q-00610	1	M18 x 30.5mm Bolt - Cover
4	STK-Q-47251-16	3	6500 MX 1600mm Vertical Frame Post Part
8	STK-Q-49445	2	6500 MX - Frame Corner Bracket Casting
16	STK-K-11001	2	3 Way Fixed Bracket Kit
8	STK-Q-47250-06	3	6500 MX 600mm Horizontal Frame Post Part
Parts List			

This drawing is confidential and must not be reproduced or used without the consent of EXM

Ce dessin est confidentiel et ne doit pas être reproduit ou utilisé sans le consentement de EXM

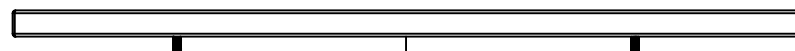

TOP

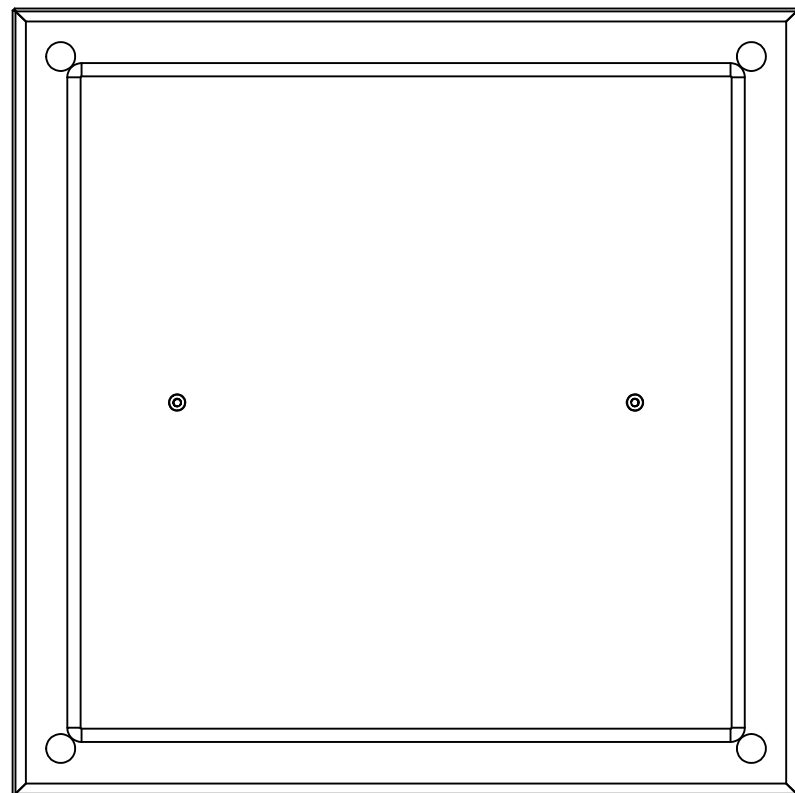

BACK

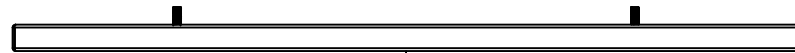

BOTTOM

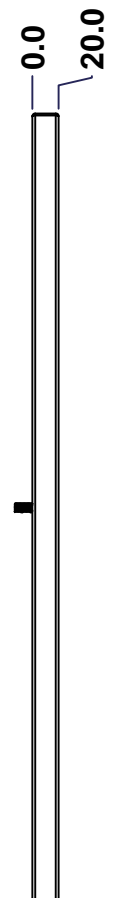

LEFT

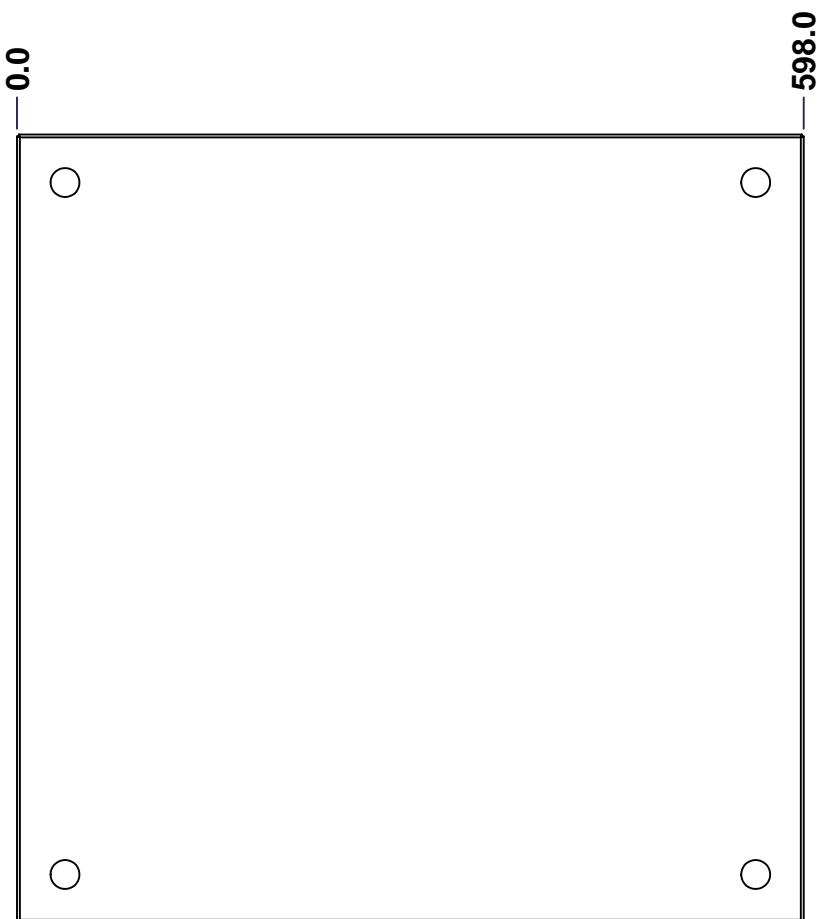

FRONT

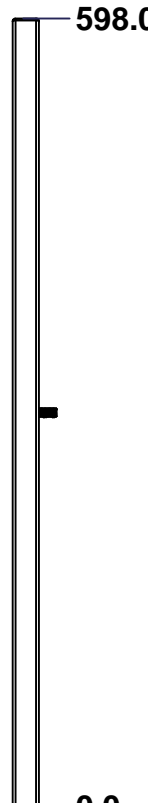

RIGHT

No.	Revisions	Date	By/Par

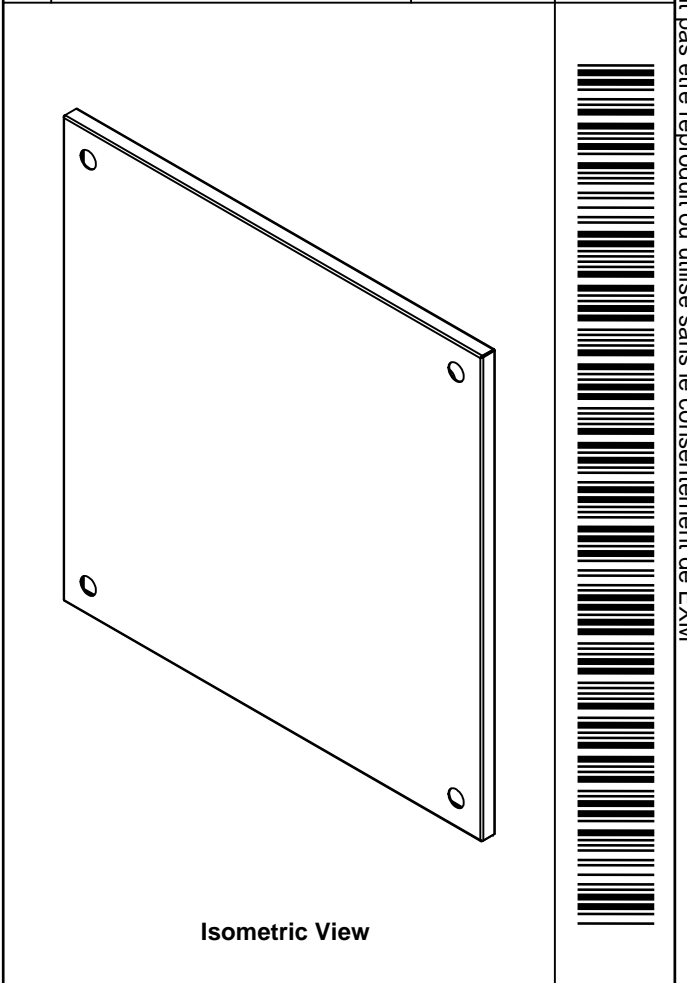

Isometric View

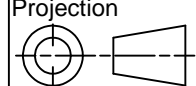

 Tél: (450) 979-4373 Fax: (450) 979-4626 <a href="http://www.exmweb.com">www.exmweb.com</a>		Flatness Aplatissement Max 3.0mm Projection 
Customer Client	Date	
Drawn By Dessiné Par	BoxCad: Annie	Date 04/03/2015
Material Matière	16 Ga H.R.P. & O. (1.4mm)	
Color Couleur	Iron Grey RAL7011	Finish Fini Rough Textured
Description 6500 MXT 600mm x 600mm Top		Detail Rev.
Part Number Numéro Pièce	6500MXU160606T	Rev. 1 0

SEE BILL OF MATERIAL ON LAST PAGE

This drawing is confidential and must not be reproduced or used without the consent of EXM

Ce dessin est confidentiel et ne doit pas être reproduit ou utilisé sans le consentement de EXM

STANDARD FEATURES ARE NOT LISTED IN THIS HOLE TABLE			
HOLE TABLE - FRONT VIEW (CUSTOM FEATURE ONLY)			
CUT-OUT	XDIM	YDIM	DESCRIPTION
1	125.0	299.0	GND STUD M6 x 16mm (Inside)
2	473.0	299.0	GND STUD M6 x 16mm (Inside)

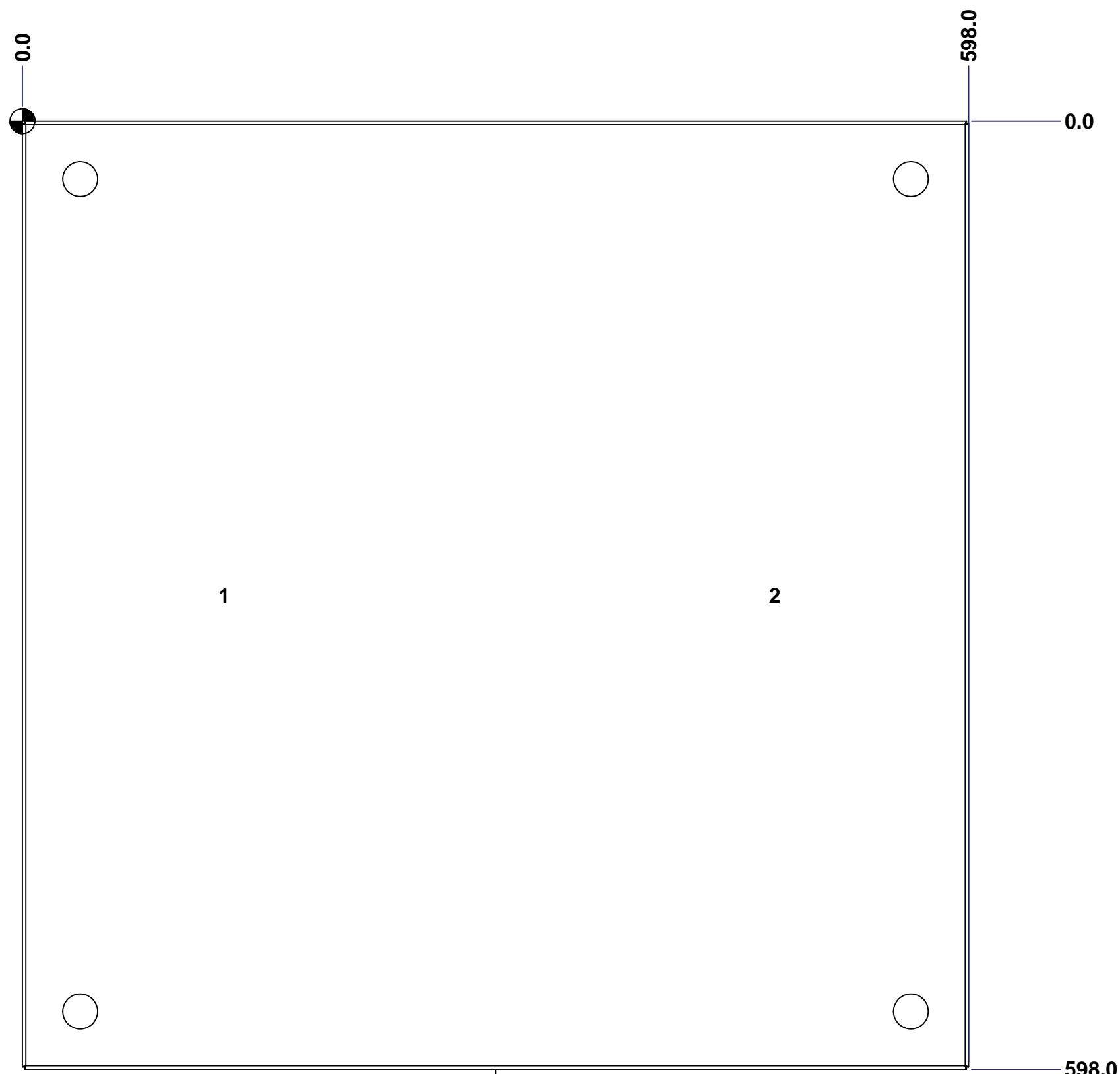

FRONT

	Description	Status
	6500 MXT 600mm x 600mm Top	(NULL)
	Part Number Numéro Pièce	Rev.
	<b>6500MXU160606T</b>	<b>0</b>
		2
		3

This drawing is confidential and must not be reproduced or used without the consent of EXM

Ce dessin est confidentiel et ne doit pas être reproduit ou utilisé sans le consentement de EXM

No.	Revisions	Date	By/Par

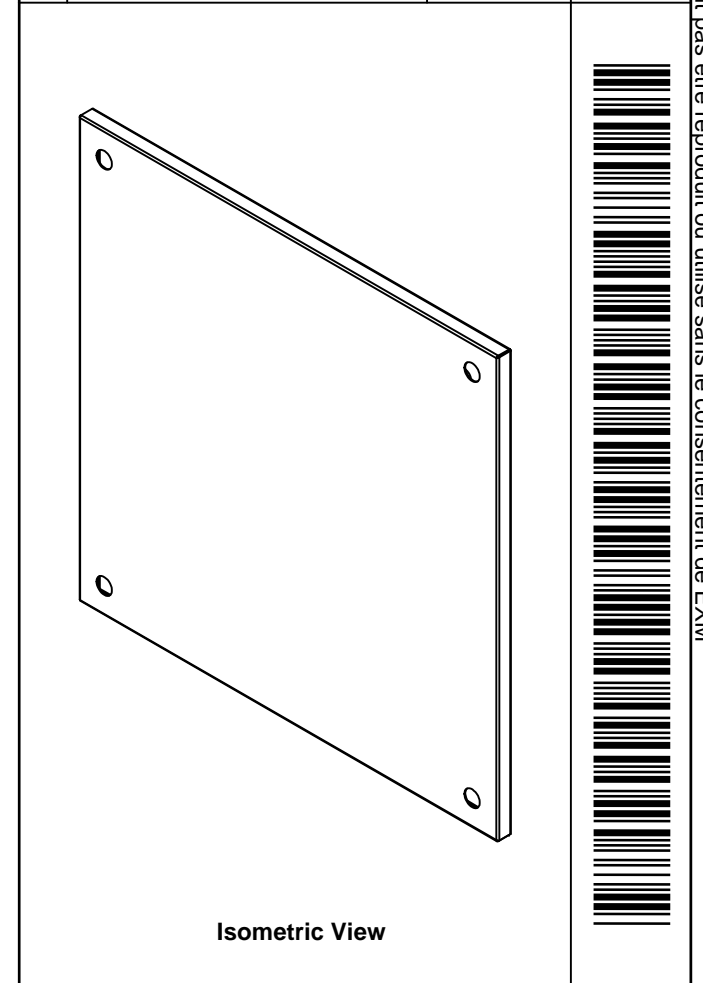

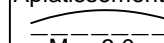
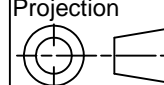
 Tél: (450) 979-4373 Fax: (450) 979-4626 <a href="http://www.exmweb.com">www.exmweb.com</a>		Flatness Aplatissement  Max 3.0mm Projection 	
Customer Client		Date	
Drawn By / Dessiné Par: BoxCad: Annie		Date: 04/03/2015	
Material / Matière: 16 Ga H.R.P. & O. (1.4mm)			
Color / Couleur: Iron Grey RAL7011		Finish / Fini: Rough Textured	
Description: 6500 MXT 600mm x 600mm Top			Detail Rev.
Part Number / Numéro Pièce: <b>6500MXU160606T</b>		Rev.:	3
		<b>0</b>	<b>3</b>

Qty	Part Number	Rev	Description
1	STK-P-03810R	0	Powder Paint (Iron Grey / Rough Textured)
2	STK-Q-16080	0.1.1	M6 x 16mm Ground Stud
1	6500MXU160606TG	0	6500 MXT 600mm x 600mm Top Gasket
1	6500MXU160606T-P	0	6500 MXT 600mm x 600mm Top Part
Parts List			

This drawing is confidential and must not be reproduced or used without the consent of EXM

Ce dessin est confidentiel et ne doit pas être reproduit ou utilisé sans le consentement de EXM



TOP

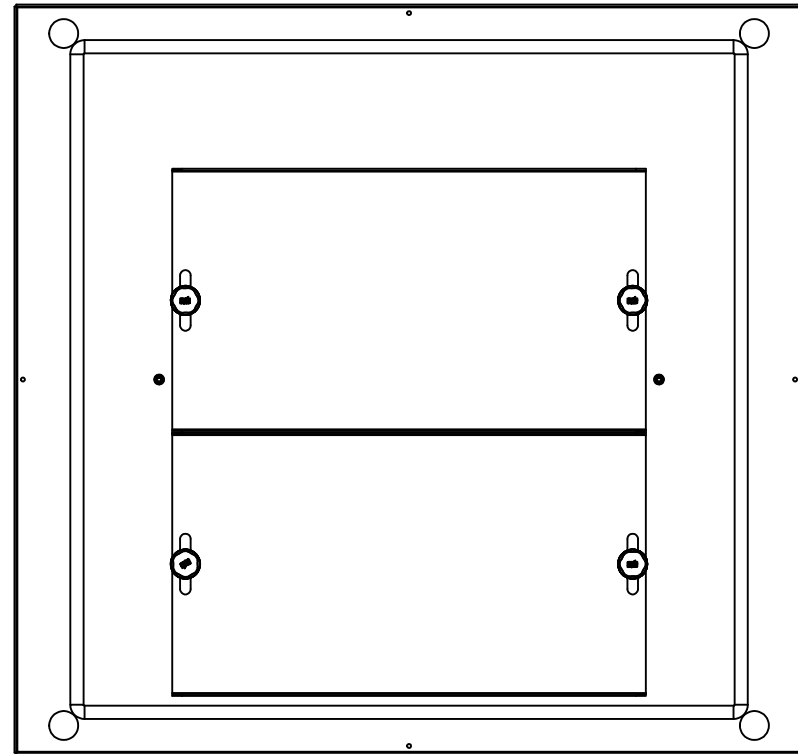

BACK

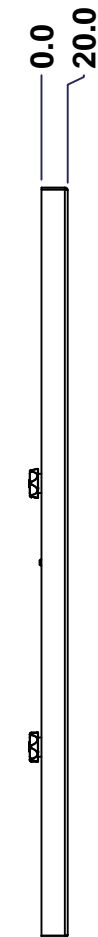

LEFT

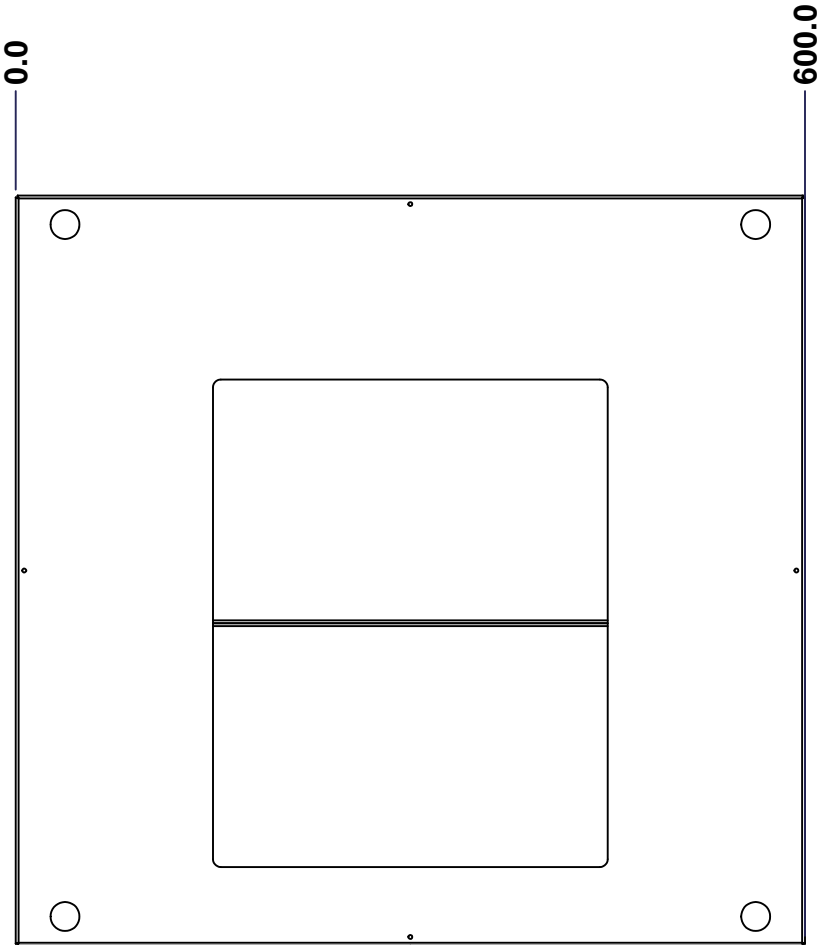

FRONT

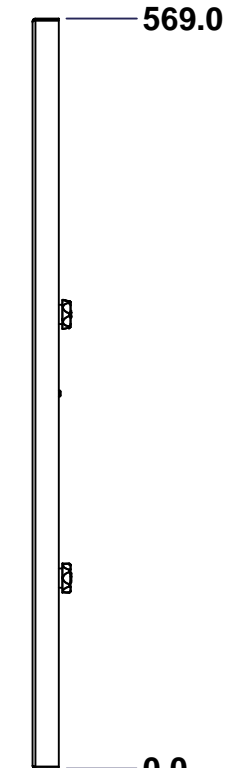

RIGHT

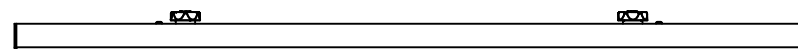

BOTTOM

No.	Revisions	Date	By/Par

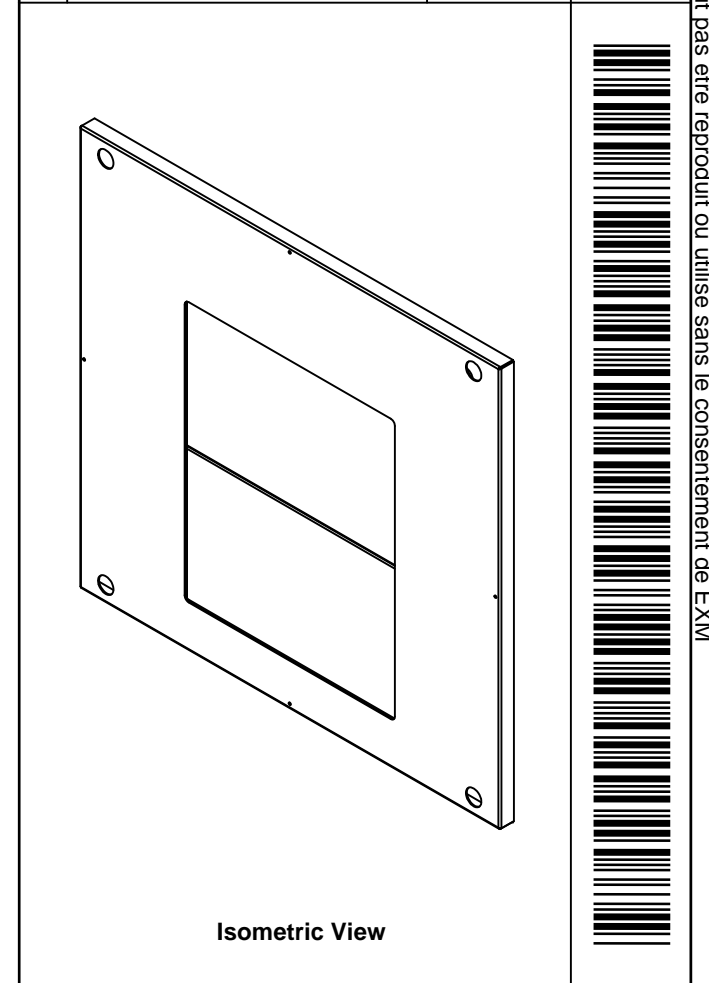

Isometric View

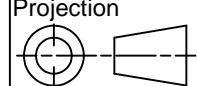
 Tél: (450) 979-4373 Fax: (450) 979-4626 <a href="http://www.exmweb.com">www.exmweb.com</a>		Flatness Aplatissement Max 3.0mm Projection 	
Customer Client		Date	
Drawn By / Dessiné Par: BoxCad: Annie		Date: 04/03/2015	
Material / Matière: 16 Ga H.R.P. & O. (1.4mm)			
Color / Couleur: Iron Grey RAL7011		Finish / Fini: Rough Textured	
Description: 6500 MXB 600mm x 600mm Bottom			Detail Rev.
Part Number / Numéro Pièce: 6500MXU160606BT		Rev. 0	1 / 3

SEE BILL OF MATERIAL ON LAST PAGE



This drawing is confidential and must not be reproduced or used without the consent of EXM

Ce dessin est confidentiel et ne doit pas être reproduit ou utilisé sans le consentement de EXM

**STANDARD FEATURES ARE NOT LISTED IN THIS HOLE TABLE**

**HOLE TABLE - FRONT VIEW (CUSTOM FEATURE ONLY)**

CUT-OUT	XDIM	YDIM	DESCRIPTION
1	110.0	284.5	GND STUD M6 x 16mm (Inside)
2	490.0	284.5	GND STUD M6 x 16mm (Inside)
3	130.0	344.5	GP STUD M6 x 10mm (Inside)
4	470.0	344.5	GP STUD M6 x 10mm (Inside)
5	130.0	144.5	GP STUD M6 x 10mm (Inside)
6	470.0	144.5	GP STUD M6 x 10mm (Inside)

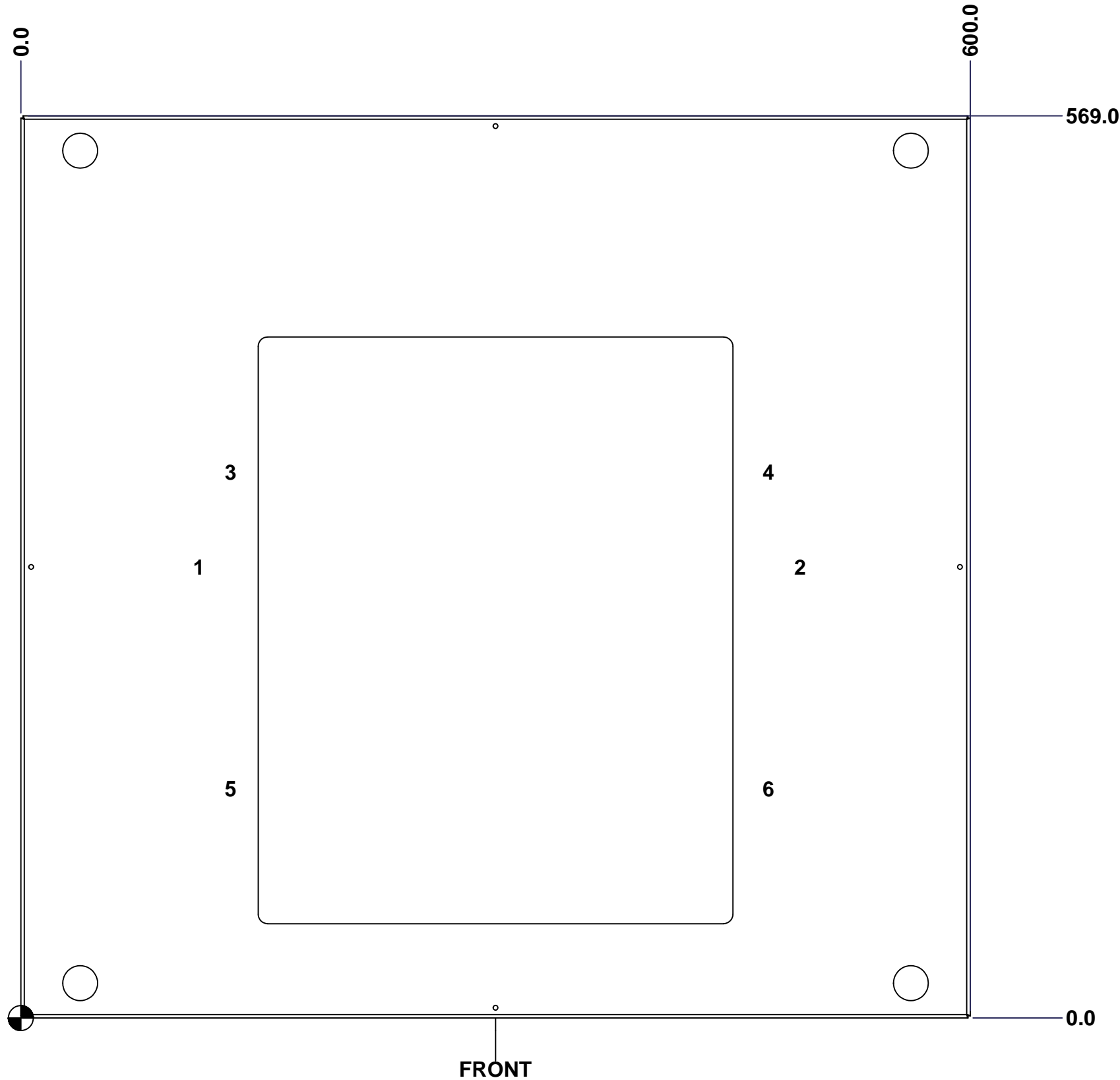

FRONT

	Description 6500 MXB 600mm x 600mm Bottom	Status (NULL)
	Part Number Numéro Pièce <b>6500MXU160606BT</b>	Rev. 2 <b>0</b>

This drawing is confidential and must not be reproduced or used without the consent of EXM

Ce dessin est confidentiel et ne doit pas être reproduit ou utilisé sans le consentement de EXM

No.	Revisions	Date	By/Par

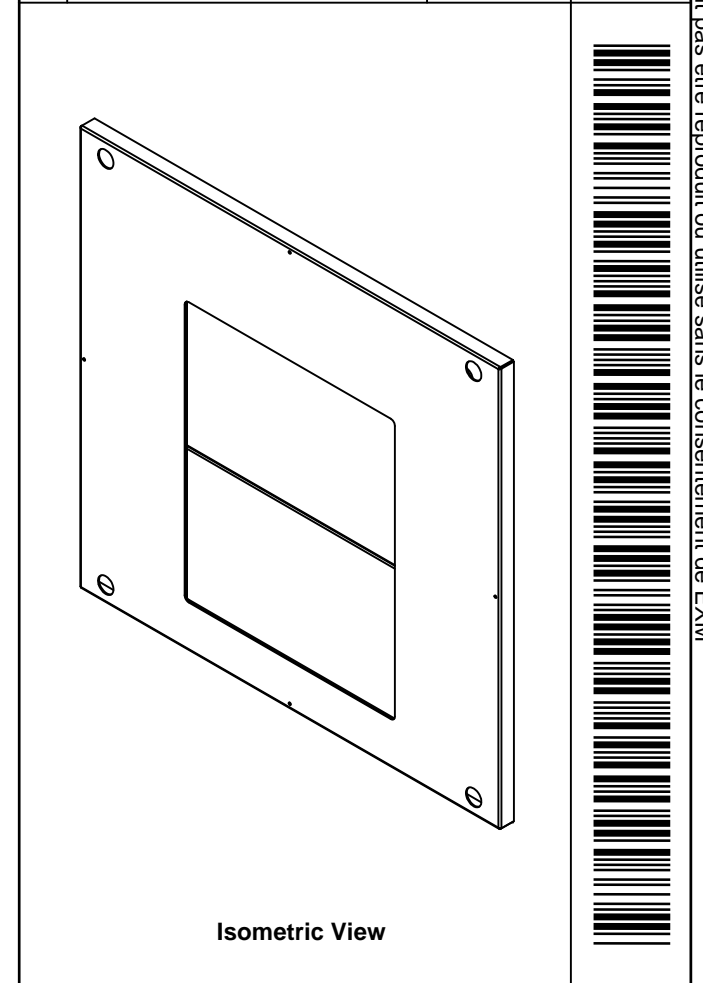

Tél: (450) 979-4373 Fax: (450) 979-4626 <a href="http://www.exmweb.com">www.exmweb.com</a>		Flatness Aplatissement	
		Max 3.0mm Projection	
Customer Client		Date	
Drawn By Dessiné Par BoxCad: Annie		Date 04/03/2015	
Material Matière		16 Ga H.R.P. & O. (1.4mm)	
Color Couleur Iron Grey RAL7011		Finish Fini Rough Textured	
Description 6500 MXB 600mm x 600mm Bottom			Detail Rev.
Part Number Numéro Pièce		Rev.	3
<b>6500MXU160606BT</b>		<b>0</b>	<b>3</b>

Qty	Part Number	Rev	Description
1	STK-P-03810R	0	Powder Paint (Iron Grey / Rough Textured)
4	STK-Q-06001	0	Mtrx - Gland Plate M6 Plastic Thumb Nut
2	STK-Q-16055	1	M6 x 18mm Stud (No Paint Cap Required)
2	6500MXU160606GP200-P	0	6500 MXB 600mm Gland Plate Part (200mm)
4	STK-Q-16031	0	M6 x 10mm Stud (No Paint Cap Required)
1	6500MXU160606BTGPG	0	6500 MXB 600mm x 600mm Bottom Gland Plate Gasket
1	6500MXU160606BTG	0	6500 MXB 600mm x 600mm Bottom Gasket
1	6500MXU160606BT-P	0	6500 MXB 600mm x 600mm Bottom Part
Parts List			

This drawing is confidential and must not be reproduced or used without the consent of EXM

Ce dessin est confidentiel et ne doit pas être reproduit ou utilisé sans le consentement de EXM

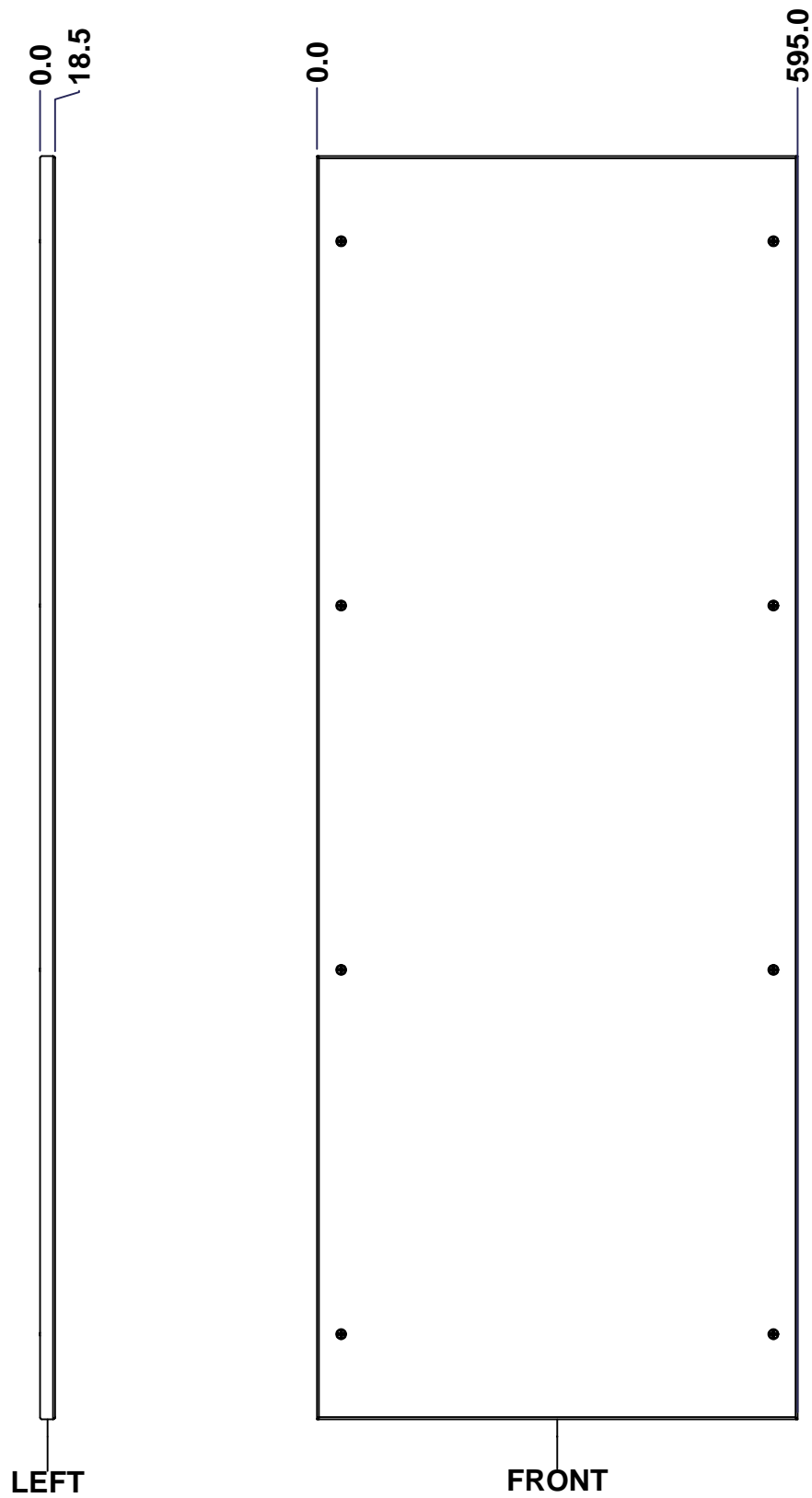
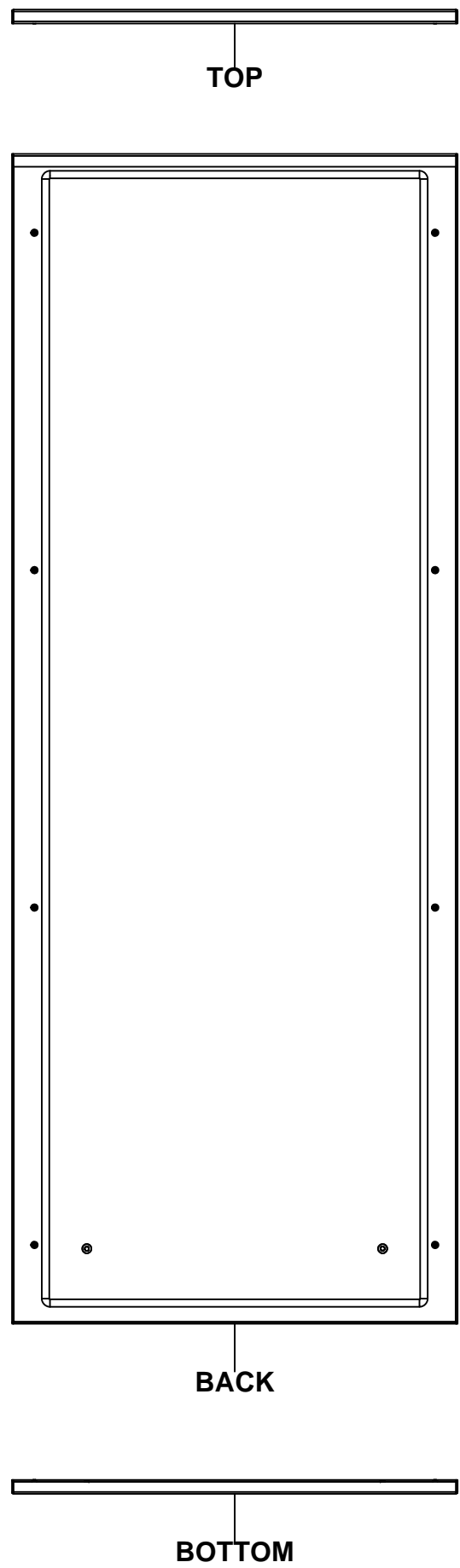

No.	Revisions	Date	By/Par

**Isometric View**

<p>Tél: (450) 979-4373 Fax: (450) 979-4626 <a href="http://www.exmweb.com">www.exmweb.com</a></p>		Flatness Aplatissement	
		Max 3.0mm	
Customer Client		Projection	
Date			
Drawn By Dessiné Par		Date	
BoxCad: Annie		04/03/2015	
Material Matière		14 Ga H.R.P. & O. (1.7mm)	
Color Couleur		Finish Fin	
Light Grey RAL7035		Rough Textured	
Description		Detail Rev.	
6500 MXR 1600mm x 600mm Back			
Part Number Numéro Pièce		Rev.	
6500MXU160606B		0	
		1	
		3	

**SEE BILL OF MATERIAL ON LAST PAGE**

This drawing is confidential and must not be reproduced or used without the consent of EXM

Ce dessin est confidentiel et ne doit pas être reproduit ou utilisé sans le consentement de EXM

STANDARD FEATURES ARE NOT LISTED IN THIS HOLE TABLE			
HOLE TABLE - FRONT VIEW (CUSTOM FEATURE ONLY)			
CUT-OUT	XDIM	YDIM	DESCRIPTION
1	100.0	100.0	GND STUD M6 x 16mm (Inside)
2	495.0	100.0	GND STUD M6 x 16mm (Inside)

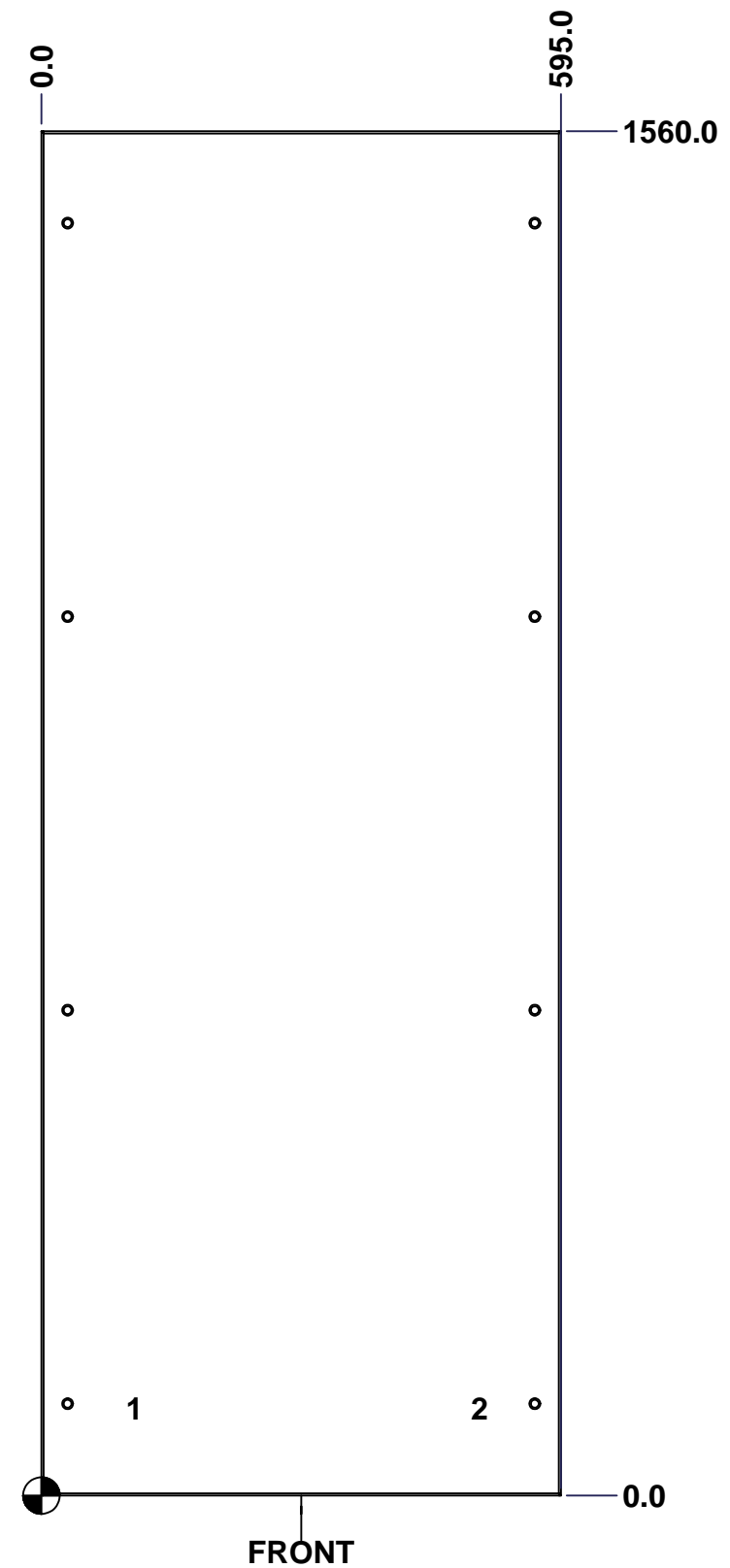



	Description	Status	
	6500 MXR 1600mm x 600mm Back	(NULL)	
	Part Number Numéro Pièce	Rev.	
	<b>6500MXU160606B</b>	<b>0</b>	2 3

This drawing is confidential and must not be reproduced or used without the consent of EXM

Ce dessin est confidentiel et ne doit pas être reproduit ou utilisé sans le consentement de EXM

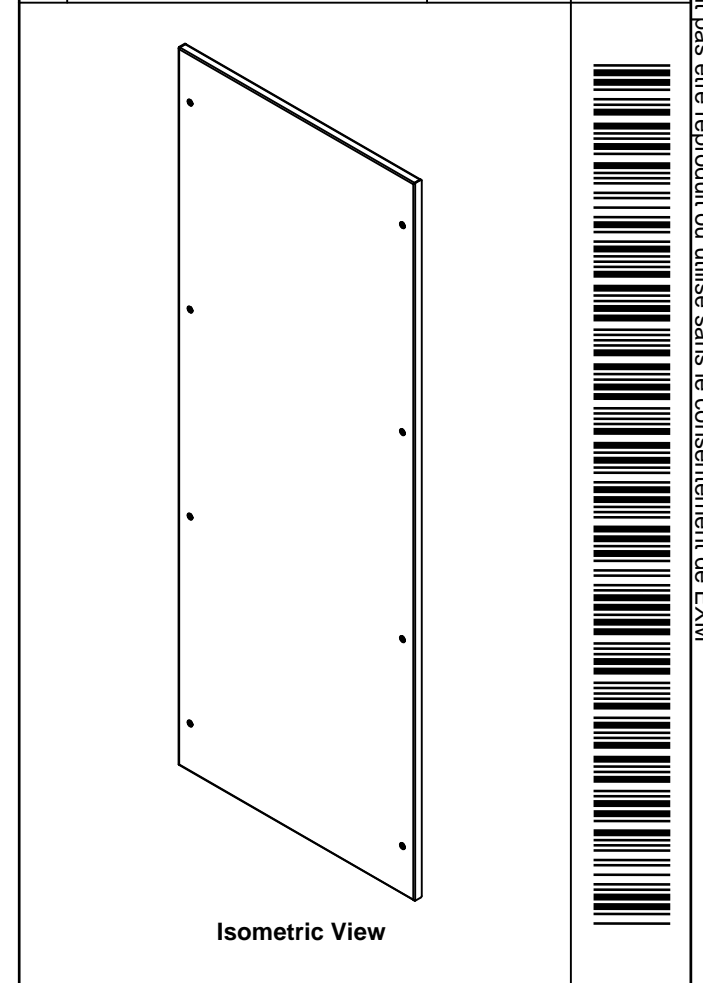
No.	Revisions	Date	By/Par

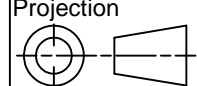

 Tél: (450) 979-4373 Fax: (450) 979-4626 <a href="http://www.exmweb.com">www.exmweb.com</a>		Flatness Aplatissement Max 3.0mm Projection 	
Customer Client		Date	
Drawn By / Dessiné Par: BoxCad: Annie		Date: 04/03/2015	
Material / Matière: 14 Ga H.R.P. & O. (1.7mm)			
Color / Couleur: Light Grey RAL7035		Finish / Fini: Rough Textured	
Description: 6500 MXR 1600mm x 600mm Back			Detail Rev.
Part Number / Numéro Pièce: <b>6500MXU160606B</b>			Rev. 3

Qty	Part Number	Rev	Description
1	STK-P-03820R	0	Powder Paint (Light Grey / Rough Textured)
8	STK-Q-03072	2	M6 x 17mm Phillips Flat Head Screw
2	STK-Q-16080	0.1.1	M6 x 16mm Ground Stud
1	6500MXU160606BG	0	6500 MXR 1600mm x 600mm Back Gasket
1	6500MXU160606B-P	0	6500 MXR 1600mm x 600mm Back Part
Parts List			

This drawing is confidential and must not be reproduced or used without the consent of EXM

Ce dessin est confidentiel et ne doit pas être reproduit ou utilisé sans le consentement de EXM

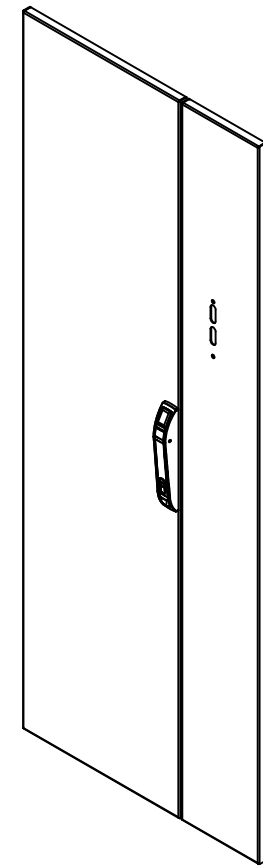
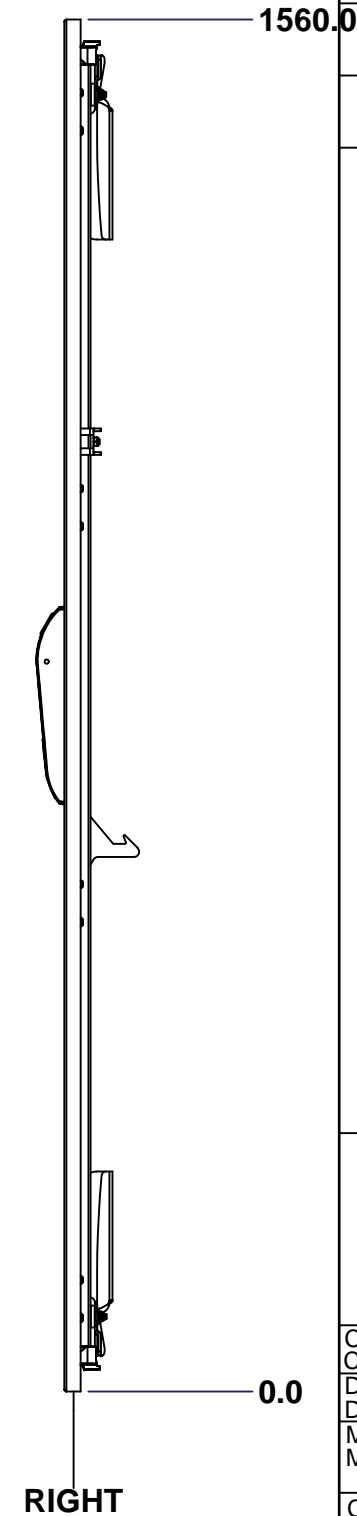
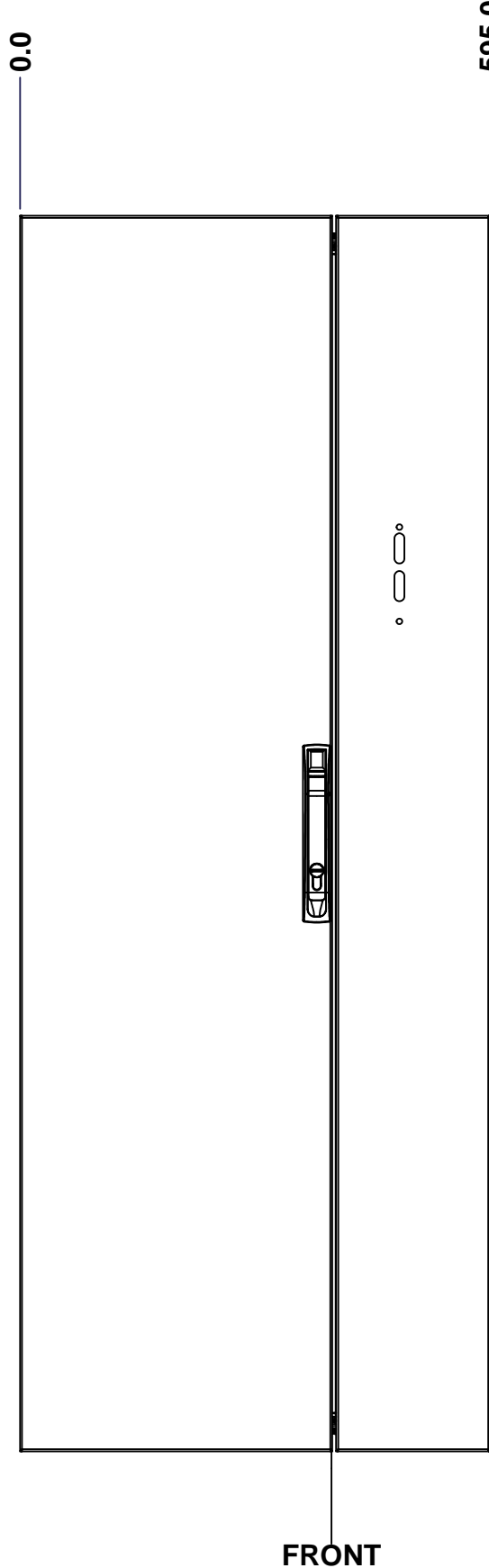
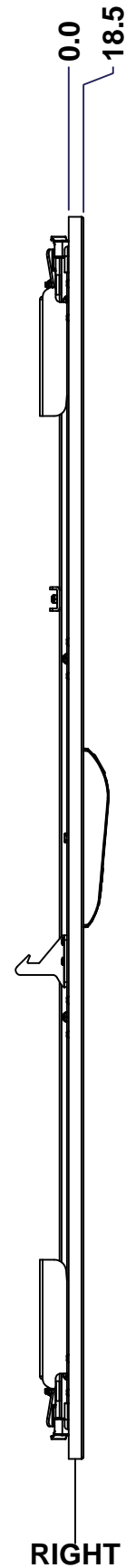
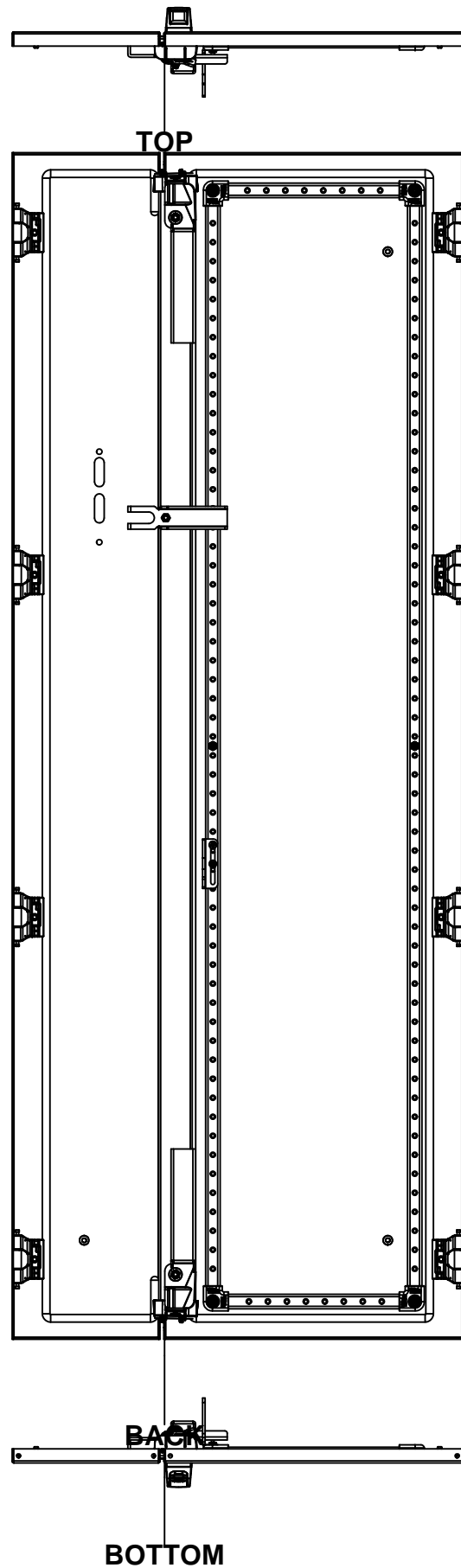

Isometric View

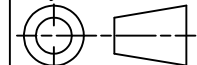

No.	Revisions	Date	By/Par

 Tél: (450) 979-4373 Fax: (450) 979-4626 <a href="http://www.exmweb.com">www.exmweb.com</a>		Flatness Aplatissement Max 3.0mm Projection 
Customer Client	Date	
Drawn By Dessiné Par	BoxCad: Annie	Date 04/03/2015
Material Matière	14 Ga H.R.P. & O. (1.7mm)	
Color Couleur	Light Grey RAL7035	Finish Fini
Description		Detail Rev.
6500 MXDU 1600mm x 600mm Front		
Part Number Numéro Pièce	Rev.	1
<b>6500MXU160606F</b>	<b>0</b>	3

SEE BILL OF MATERIAL ON LAST PAGE

This drawing is confidential and must not be reproduced or used without the consent of EXM

Ce dessin est confidentiel et ne doit pas être reproduit ou utilisé sans le consentement de EXM

**STANDARD FEATURES ARE NOT LISTED IN THIS HOLE TABLE**

**HOLE TABLE - FRONT VIEW (CUSTOM FEATURE ONLY)**

CUT-OUT	XDIM	YDIM	DESCRIPTION
1	100.0	130.0	GND STUD M6 x 16mm (Inside)
2	495.0	130.0	GND STUD M6 x 16mm (Inside)
3	495.0	1430.0	GND STUD M6 x 16mm (Inside)
4	264.5	49.5	STIFF. STUD M6 x 18mm (Inside)
5	264.5	780.0	STIFF. STUD M6 x 18mm (Inside)
6	264.5	1510.5	STIFF. STUD M6 x 18mm (Inside)
7	530.5	49.5	STIFF. STUD M6 x 18mm (Inside)
8	530.5	780.0	STIFF. STUD M6 x 18mm (Inside)
9	530.5	1510.5	STIFF. STUD M6 x 18mm (Inside)
10	175.5	155.0	CLOSING BAR GUIDE (Inside)
11	175.5	1405.0	CLOSING BAR GUIDE (Inside)
12	175.5	605.0	CLOSING BAR GUIDE (Inside)
13	175.5	955.0	CLOSING BAR GUIDE (Inside)

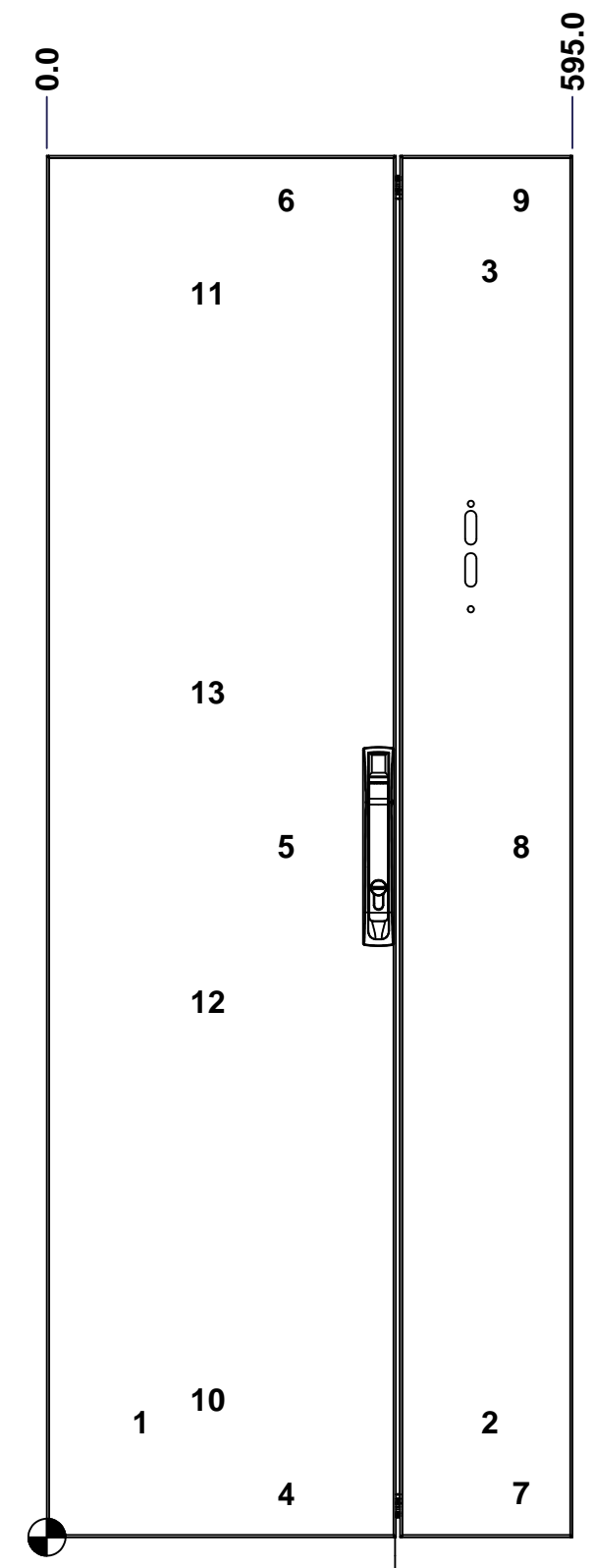

FRONT

	Description	Status	
	6500 MXDU 1600mm x 600mm Front	(NULL)	
	Part Number Numéro Pièce	Rev.	
	<b>6500MXU160606F</b>	<b>0</b>	2 3

This drawing is confidential and must not be reproduced or used without the consent of EXM

Ce dessin est confidentiel et ne doit pas être reproduit ou utilisé sans le consentement de EXM

No.	Revisions	Date	By/Par

1	STK-P-03820R	0	Powder Paint (Light Grey / Rough Textured)
1	STK-Q-46650	3	6500 MXDU Disconnect Hook
1	STK-Q-45746-16	1	6500 MXD - Lock Door Closing Bar
2	STK-Q-05020	5	M5 x 8mm Thread Rolling Screw
1	STK-Q-07220	0	M6 Nylon Insert Lock Nut
1	STK-Q-46750	4	6500 MXDU Disconnect Defeater
1	STK-K-10102	0	6500MX - Lock Handle Kit for Flange Door - Right
1	STK-K-10101	0	6500MX - Lock Handle Kit for Flange Door - Left
1	STK-Q-16030	0	Stud M6 x 10mm
2	STK-Q-16050	0	Stud M6 x 18mm
1	STK-K-06811-27	1	6500 MX - Hinge Assy
1	STK-K-06811-26	1	6500 MX - Hinge Assy
1	STK-K-06811-31	1	6500 MX - Hinge Assy
1	STK-K-06811-30	1	6500 MX - Hinge Assy
4	STK-Q-03061	2	M6 x 6.5mm Stainless Steel Phillips Flat Head Screw
4	STK-Q-70483	1	Flange Door Bracket
4	STK-Q-05010	0	M5 x 12mm Flat Head Thread Rolling Screw
1	STK-Q-74700-2	5	6500 MX - Flange Door Sealing Block
1	STK-Q-74700-1	5	6500 MX - Flange Door Sealing Block
1	STK-K-06811-32	1	6500 MX - Hinge Assy
1	STK-K-06811-29	1	6500 MX - Hinge Assy
1	6500MXU160606F1G	0	6500 MXDU 1600mm x 600mm Front Gasket
1	6500MXU160606F1-P	0	6500 MXDU 1600mm x 600mm Front Part
4	STK-Q-78022	0	Mtrx Closing Bar Slider
1	STK-Q-45729-16	2	6500 MXD - Lock Door Top Closing Bar
1	STK-A-886PHD-S-1_Right	4	Euroform Pull Handle Kit
6	STK-Q-16055	1	M6 x 18mm Stud (No Paint Cap Required)
1	STK-K-06811-25	1	6500 MX - Hinge Assy
1	STK-K-06811-28	1	6500 MX - Hinge Assy
8	STK-Q-33105	4	5412 ESBU Buttable Hinge (Cover Part)
3	STK-Q-16080	0.1.1	M6 x 16mm Ground Stud
1	6500MXU160606DS1	5	6500 MX 1600mm x 600mm Door Stiffener
1	6500MXU160606FG	0	6500 MXDU 1600mm x 600mm Front Gasket
1	6500MXU160606F-P	0	6500 MXDU 1600mm x 600mm Front Part
Qty	Part Number	Rev.	Description

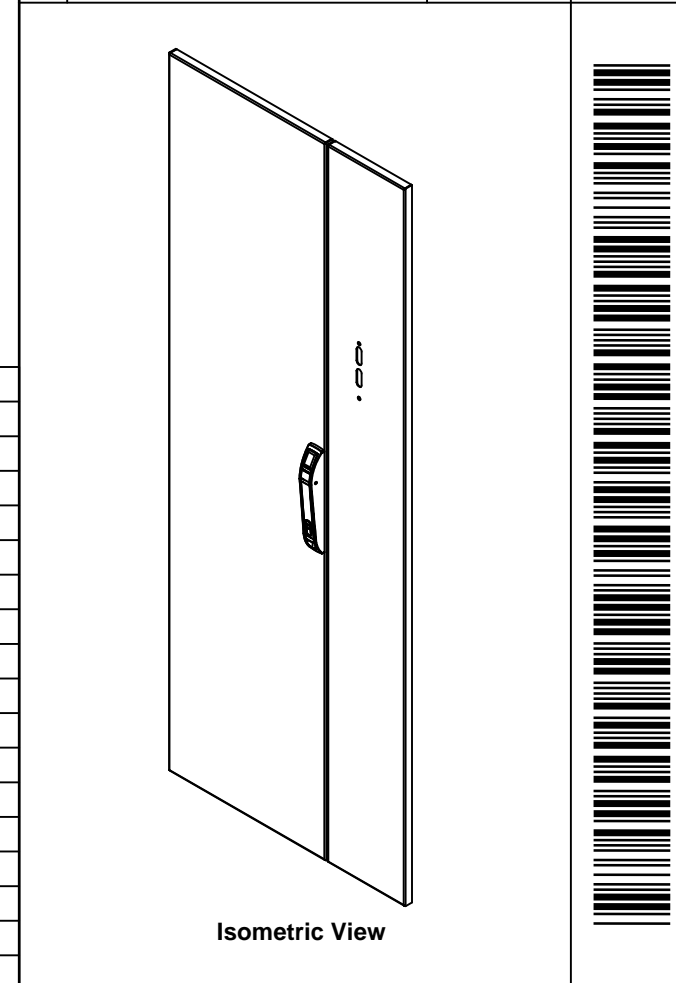

	Tél: (450) 979-4373 Fax: (450) 979-4626 <a href="http://www.exmweb.com">www.exmweb.com</a>	Flatness Aplatissement Max 3.0mm
	Projection	
Customer Client	Date	
Drawn By Dessiné Par	BoxCad: Annie	Date 04/03/2015
Material Matière	14 Ga H.R.P. & O. (1.7mm)	
Color Couleur	Light Grey RAL7035	Finish Fini Rough Textured
Description	6500 MXDU 1600mm x 600mm Front	
Part Number Numéro Pièce	<b>6500MXU160606F</b>	Rev. 0
		3 3

Parts List



This drawing is confidential and must not be reproduced or used without the consent of EXM

Ce dessin est confidentiel et ne doit pas être reproduit ou utilisé sans le consentement de EXM

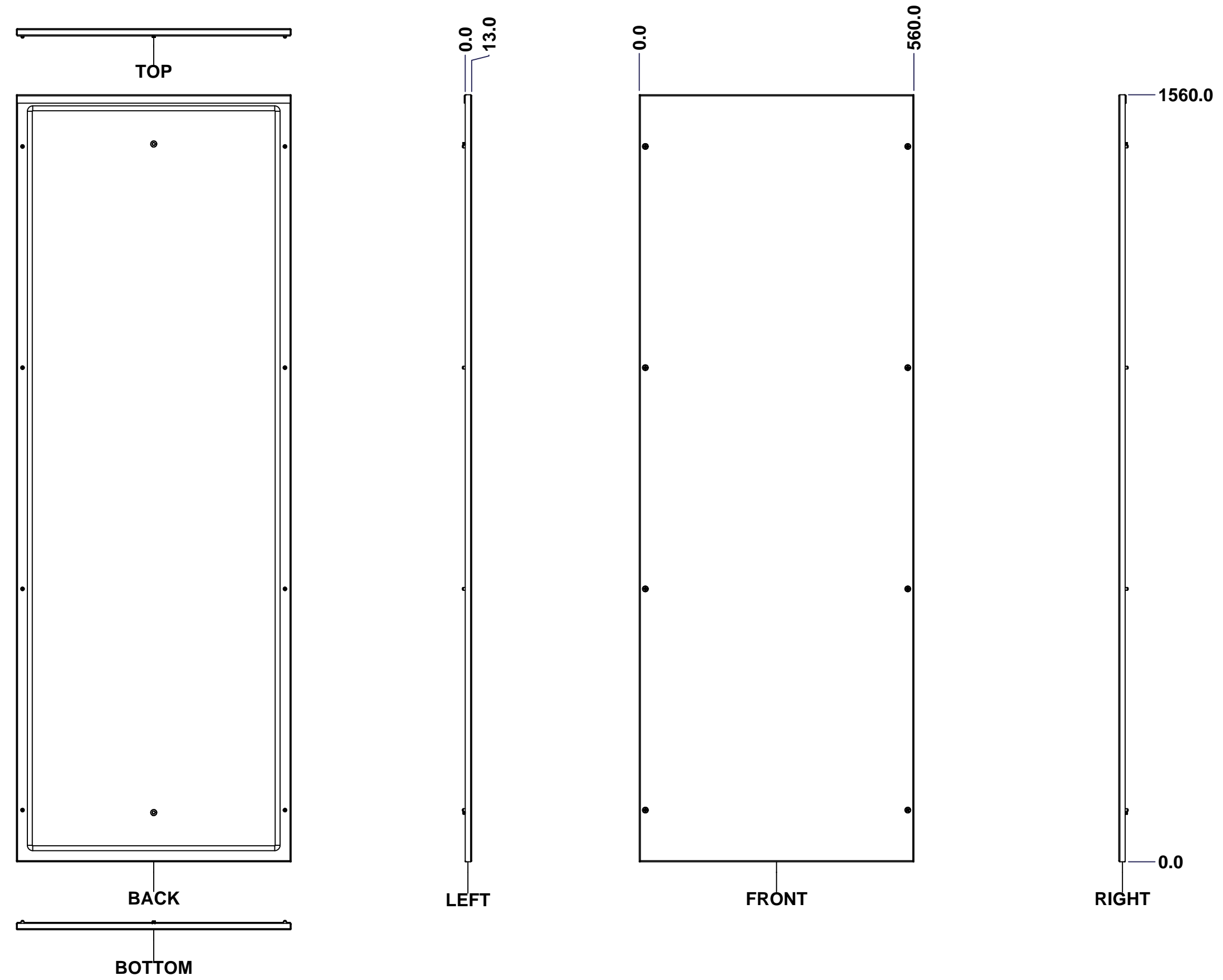

No.	Revisions	Date	By/Par

**Isometric View**

<p>Tél: (450) 979-4373 Fax: (450) 979-4626 <a href="http://www.exmweb.com">www.exmweb.com</a></p>		Flatness Aplatissement	
		Max 3.0mm	
Customer Client		Projection	
Date			
Drawn By Dessiné Par		Date	
BoxCad: Annie		04/03/2015	
Material Matière		16 Ga H.R.P. & O. (1.4mm)	
Color Couleur		Finish Fin	
Light Grey RAL7035		Rough Textured	
Description		Detail Rev.	
6500 MXC 1600mm x 600mm Left			
Part Number Numéro Pièce		Rev.	
<b>6500MXU160606L</b>		<b>0</b>	1 3

**SEE BILL OF MATERIAL ON LAST PAGE**

This drawing is confidential and must not be reproduced or used without the consent of EXM

Ce dessin est confidentiel et ne doit pas être reproduit ou utilisé sans le consentement de EXM

STANDARD FEATURES ARE NOT LISTED IN THIS HOLE TABLE			
HOLE TABLE - FRONT VIEW (CUSTOM FEATURE ONLY)			
CUT-OUT	XDIM	YDIM	DESCRIPTION
1	280.0	100.0	GND STUD M6 x 16mm (Inside)
2	280.0	1460.0	GND STUD M6 x 16mm (Inside)

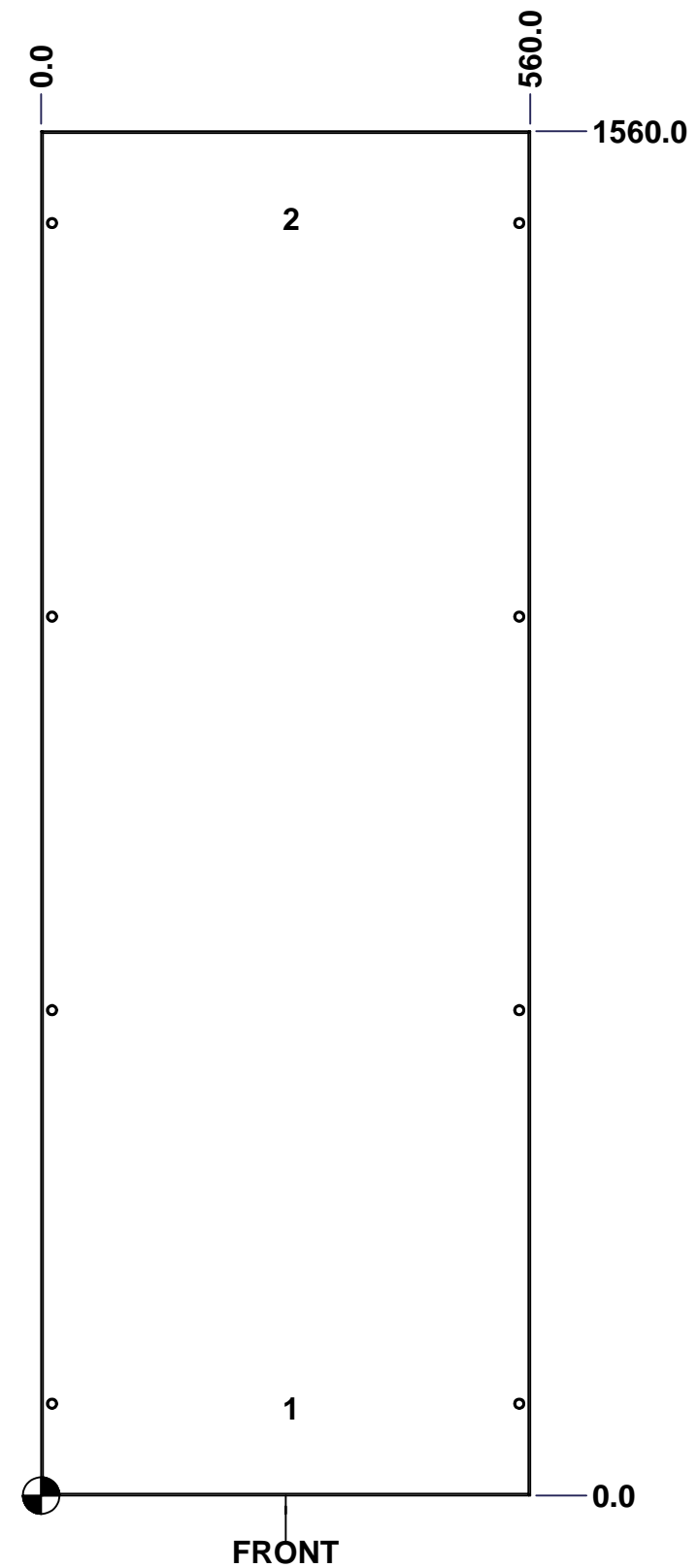



	Description	Status
	6500 MXC 1600mm x 600mm Left	(NULL)
	Part Number Numéro Pièce	Rev.
	<b>6500MXU160606L</b>	<b>0</b>
		2
		3

This drawing is confidential and must not be reproduced or used without the consent of EXM

Ce dessin est confidentiel et ne doit pas être reproduit ou utilisé sans le consentement de EXM

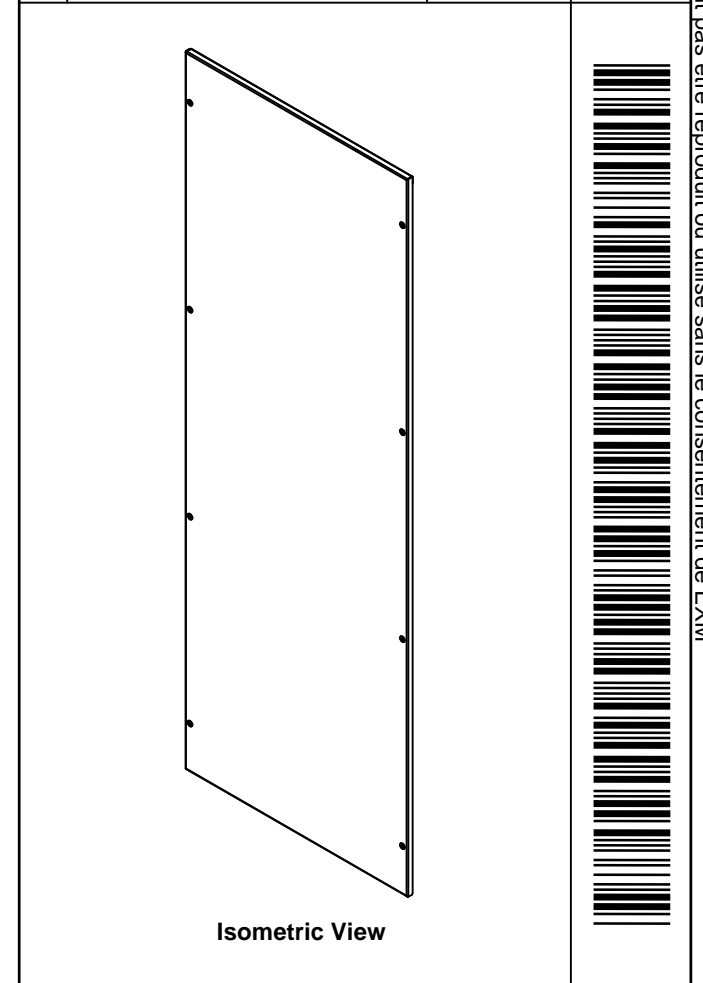
No.	Revisions	Date	By/Par

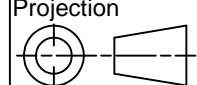

 Tél: (450) 979-4373 Fax: (450) 979-4626 <a href="http://www.exmweb.com">www.exmweb.com</a>		Flatness Aplatissement Max 3.0mm Projection 
Customer Client	Date	
Drawn By Dessiné Par	BoxCad: Annie	Date 04/03/2015
Material Matière	16 Ga H.R.P. & O. (1.4mm)	
Color Couleur	Light Grey RAL7035	Finish Fini Rough Textured
Description	Detail Rev.	
6500 MXC 1600mm x 600mm Left		
Part Number Numéro Pièce	Rev.	3
<b>6500MXU160606L</b>	<b>0</b>	<b>3</b>

Qty	Part Number	Rev	Description
1	STK-P-03820R	0	Powder Paint (Light Grey / Rough Textured)
8	STK-Q-03072	2	M6 x 17mm Phillips Flat Head Screw
2	STK-Q-16080	0.1.1	M6 x 16mm Ground Stud
1	6500MXU160606LG	0	6500 MXC 1600mm x 600mm Left Gasket
1	6500MXU160606L-P	0	6500 MXC 1600mm x 600mm Left Part
Parts List			

This drawing is confidential and must not be reproduced or used without the consent of EXM

Ce dessin est confidentiel et ne doit pas être reproduit ou utilisé sans le consentement de EXM

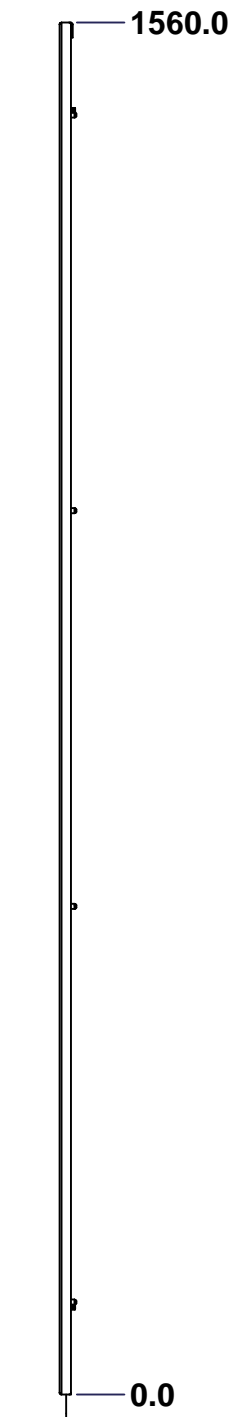
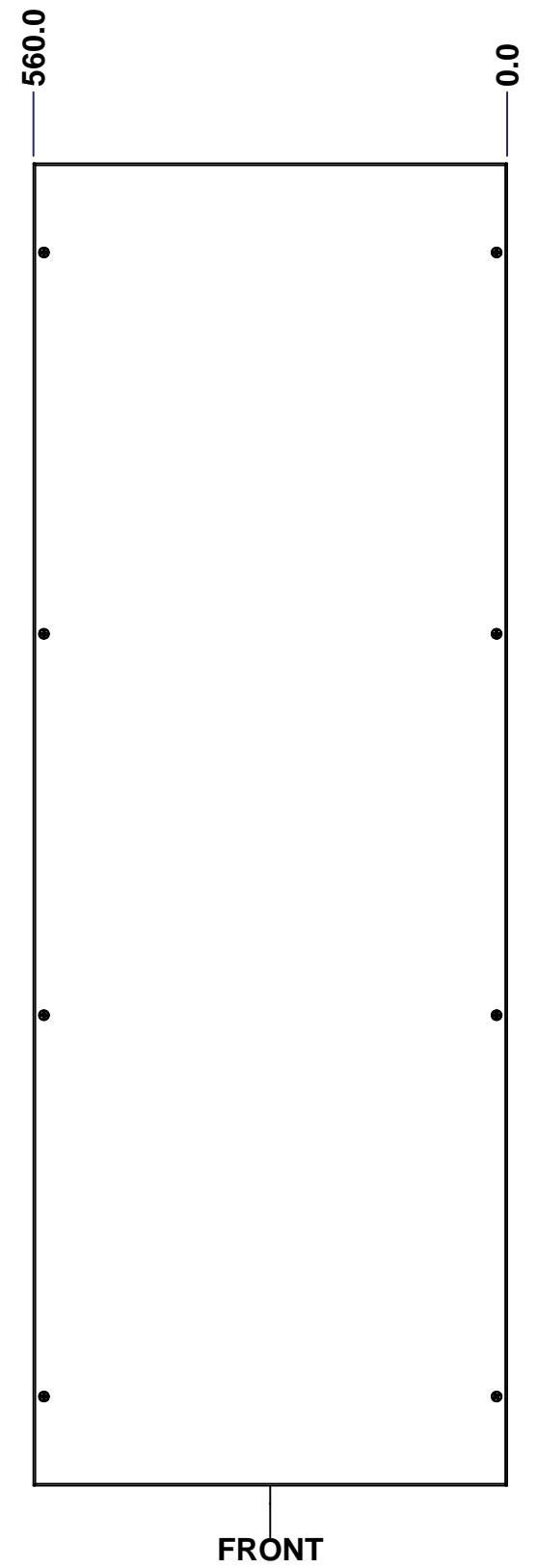
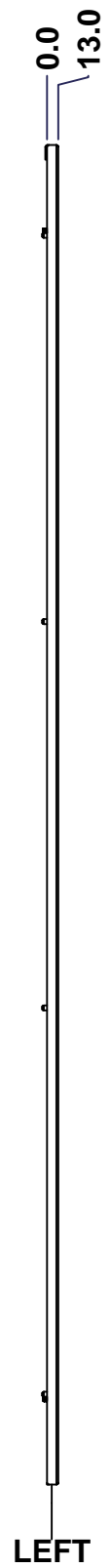
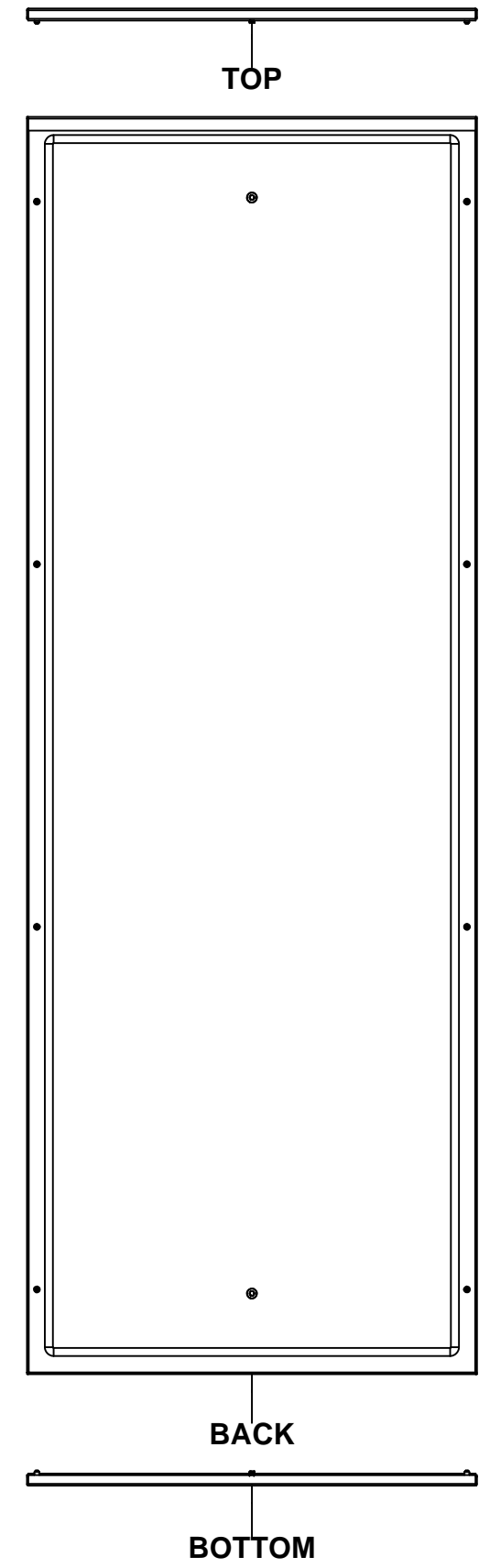

No.	Revisions	Date	By/Par

**Isometric View**

<p>Tél: (450) 979-4373 Fax: (450) 979-4626 <a href="http://www.exmweb.com">www.exmweb.com</a></p>		Flatness Aplatissement	
		Max 3.0mm	
Customer Client		Projection	
Date			
Drawn By Dessiné Par: BoxCad: Annie		Date: 04/03/2015	
Material Matière: 16 Ga H.R.P. & O. (1.4mm)		Color Couleur: Light Grey RAL7035	
Description 6500 MXC 1600mm x 600mm Right		Finish Fin: Rough Textured	
Part Number Numéro Pièce: <b>6500MXU160606R</b>		Detail Rev.	
SEE BILL OF MATERIAL ON LAST PAGE		Rev. <b>0</b>	1 / 3

This drawing is confidential and must not be reproduced or used without the consent of EXM

Ce dessin est confidentiel et ne doit pas être reproduit ou utilisé sans le consentement de EXM

STANDARD FEATURES ARE NOT LISTED IN THIS HOLE TABLE			
HOLE TABLE - FRONT VIEW (CUSTOM FEATURE ONLY)			
CUT-OUT	XDIM	YDIM	DESCRIPTION
1	280.0	100.0	GND STUD M6 x 16mm (Inside)
2	280.0	1460.0	GND STUD M6 x 16mm (Inside)

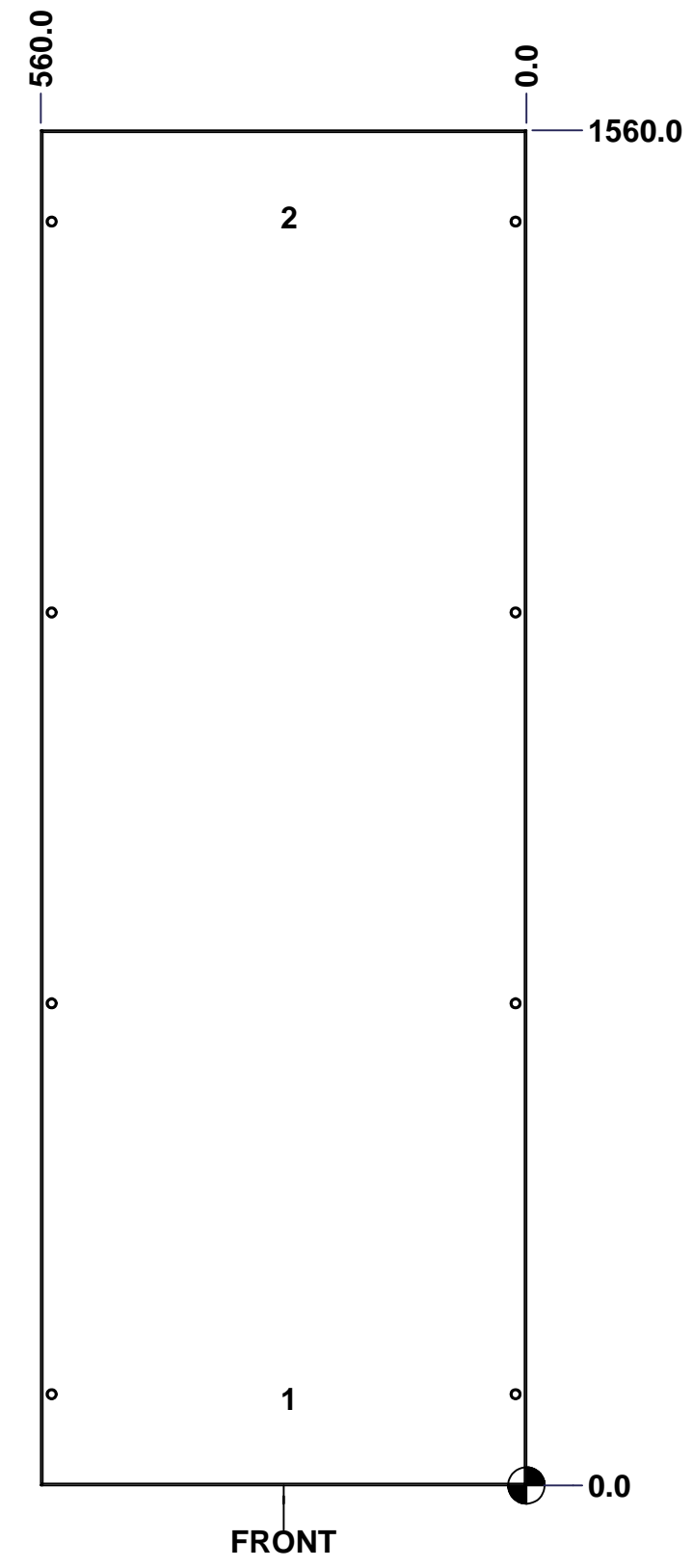



	Description	Status
	6500 MXC 1600mm x 600mm Right	(NULL)
	Part Number Numéro Pièce	Rev.
	<b>6500MXU160606R</b>	<b>0</b>
		2
		3

This drawing is confidential and must not be reproduced or used without the consent of EXM

Ce dessin est confidentiel et ne doit pas être reproduit ou utilisé sans le consentement de EXM

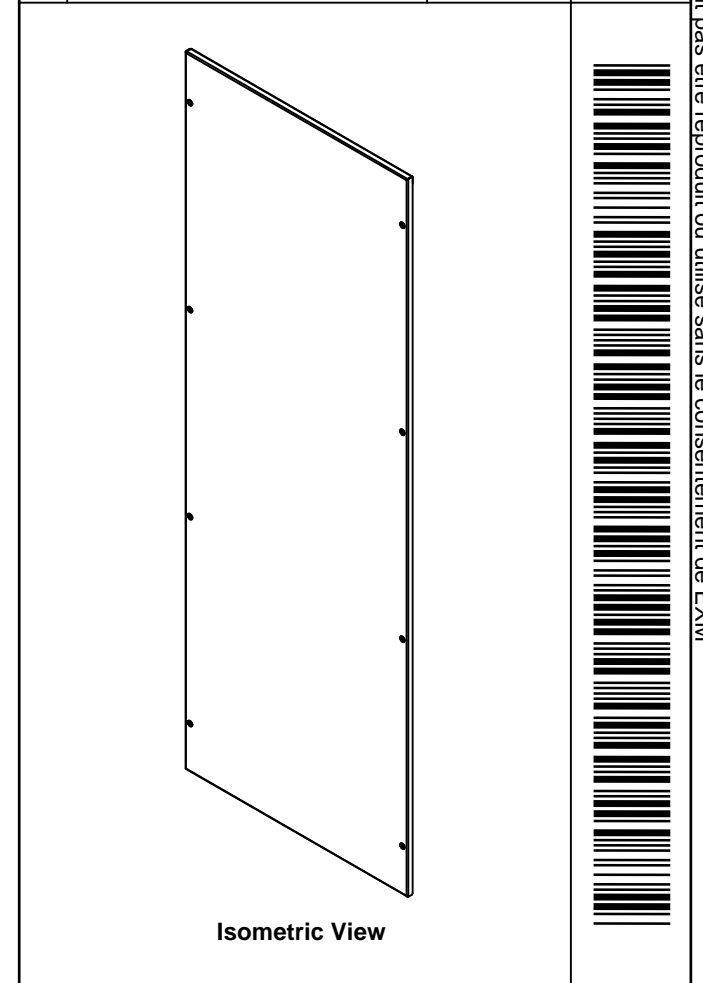
No.	Revisions	Date	By/Par

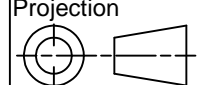

 Tél: (450) 979-4373 Fax: (450) 979-4626 <a href="http://www.exmweb.com">www.exmweb.com</a>		Flatness Aplatissement Max 3.0mm Projection 
Customer Client	Date	
Drawn By Dessiné Par	BoxCad: Annie	Date 04/03/2015
Material Matière	16 Ga H.R.P. & O. (1.4mm)	
Color Couleur	Light Grey RAL7035	Finish Fini Rough Textured
Description	Detail Rev.	
6500 MXC 1600mm x 600mm Right		
Part Number Numéro Pièce	Rev.	3
<b>6500MXU160606R</b>	<b>0</b>	<b>3</b>

Qty	Part Number	Rev	Description
1	STK-P-03820R	0	Powder Paint (Light Grey / Rough Textured)
8	STK-Q-03072	2	M6 x 17mm Phillips Flat Head Screw
2	STK-Q-16080	0.1.1	M6 x 16mm Ground Stud
1	6500MXU160606RG	0	6500 MXC 1600mm x 600mm Right Gasket
1	6500MXU160606R-P	0	6500 MXC 1600mm x 600mm Right Part
Parts List			

This drawing is confidential and must not be reproduced or used without the consent of EXM

Ce dessin est confidentiel et ne doit pas être reproduit ou utilisé sans le consentement de EXM

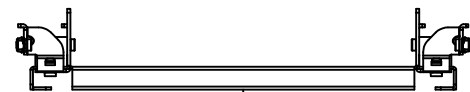

TOP

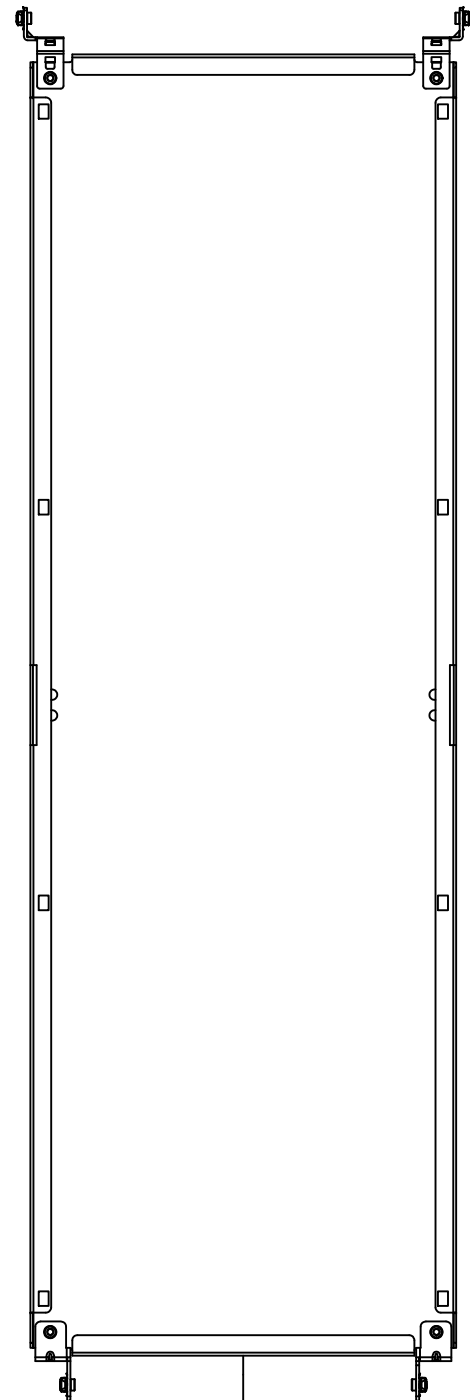

BACK



BOTTOM

0.0  
26.0

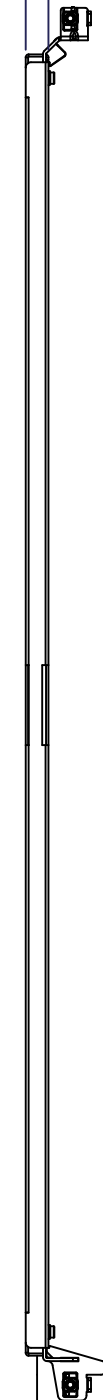

LEFT

0.0  
485.0

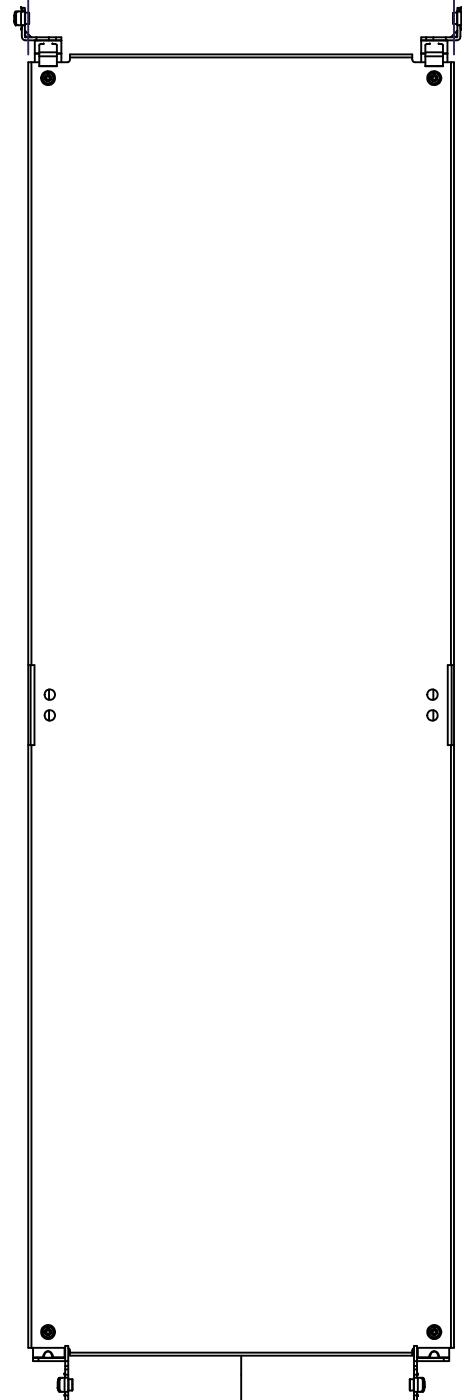

FRONT

1480.0

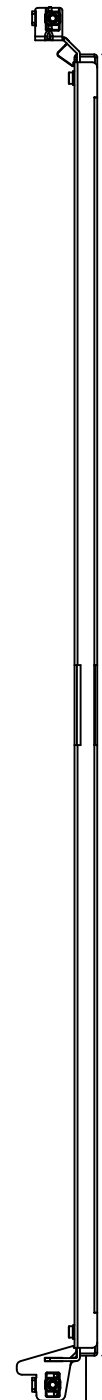

RIGHT

0.0

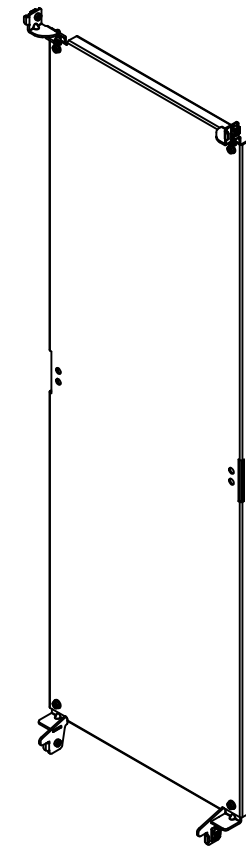

Isometric View

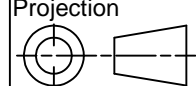

No.	Revisions	Date	By/Par

 Tél: (450) 979-4373 Fax: (450) 979-4626 <a href="http://www.exmweb.com">www.exmweb.com</a>		Flatness Aplatissement Max 3.0mm Projection 
Customer Client	Date	
Drawn By Dessiné Par	BoxCad: Annie	Date 04/03/2015
Material Matière	12 Ga Galvanized (2.5mm)	
Color Couleur	Unpainted	Finish Fini Unpainted
Description	Detail Rev.	
6500 MXM 1600mm x 600mm Back Inner Panel		
Part Number Numéro Pièce	Rev.	1
<b>6500MXU160606BIP</b>	<b>0</b>	3

SEE BILL OF MATERIAL ON LAST PAGE

This drawing is confidential and must not be reproduced or used without the consent of EXM

Ce dessin est confidentiel et ne doit pas être reproduit ou utilisé sans le consentement de EXM

No.	Revisions	Date	By/Par

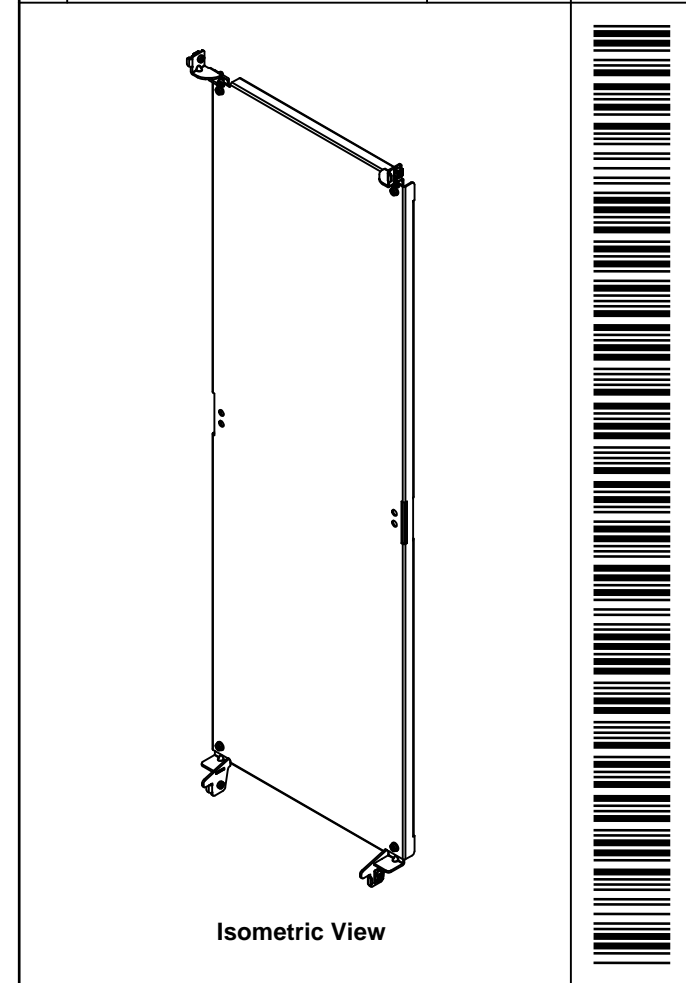

Tél: (450) 979-4373 Fax: (450) 979-4626 <a href="http://www.exmweb.com">www.exmweb.com</a>		Flatness Aplatissement
		Max 3.0mm
Projection		
Customer Client		Date
Drawn By Dessiné Par	BoxCad: Annie	Date 04/03/2015
Material Matière		
12 Ga Galvanized (2.5mm)		
Color Couleur	Unpainted	Finish Fini
		Unpainted
Description		Detail Rev.
6500 MXM 1600mm x 600mm Back Inner Panel		
Part Number Numéro Pièce		Rev. 3
<b>6500MXU160606BIP</b>		<b>0</b>

Qty	Part Number	Rev	Description
1	STK-A-49005	0	6500MXM - Bottom Inner Panel Support Kit (Right)
1	STK-A-49000	0	6500MXM - Bottom Inner Panel Support Kit (Left)
1	STK-A-49015	0	6500MXM - Top Inner Panel Support Kit (Right)
1	STK-A-49010	0	6500MXM - Top Inner Panel Support Kit (Left)
1	6500MXU160606BIP-P	0	6500 MXM 1600mm x 600mm Back Inner Panel Part
Parts List			