

This drawing is confidential and must not be reproduced or used without the consent of EXM

Ce dessin est confidentiel et ne doit pas être reproduit ou utilisé sans le consentement de EXM

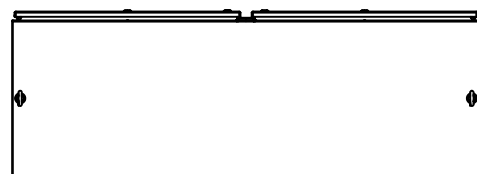

TOP

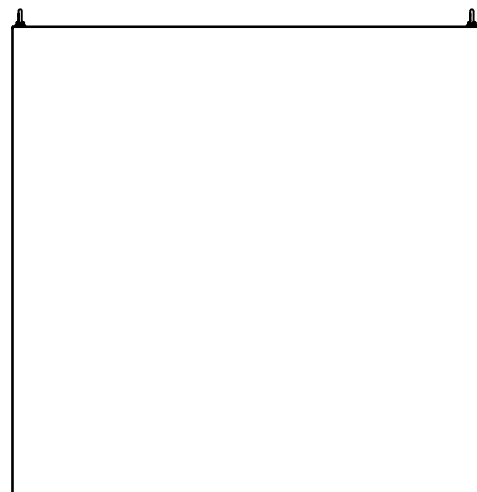

BACK



LEFT

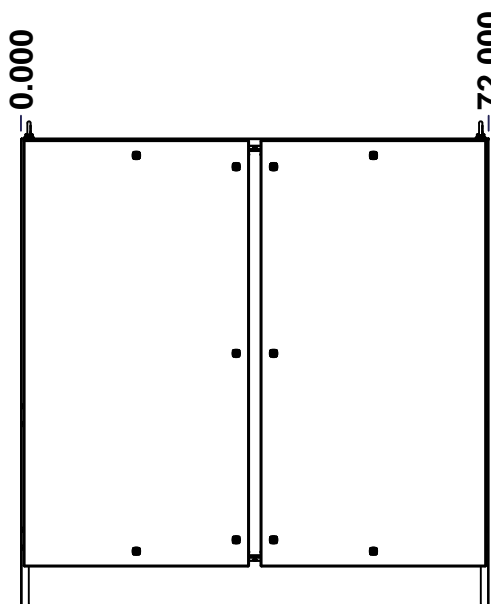

FRONT

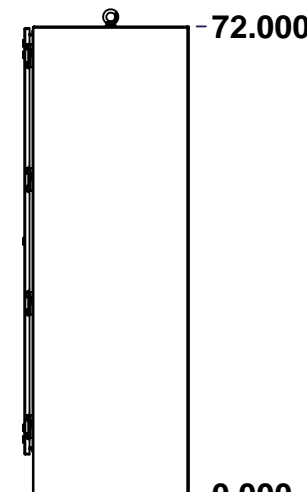

RIGHT



BOTTOM

No.	Revisions	Date	By/Par

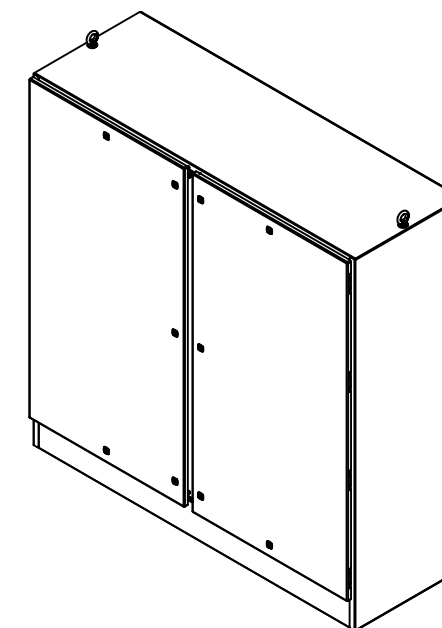

Isometric View



Tél: (450) 979-4373  
 Fax: (450) 979-4626  
[www.exmweb.com](http://www.exmweb.com)

Flatness  
Aplatissement

Max 3.0mm

Projection



Customer Client	Date
Drawn By Dessiné Par	Date

BoxCad: BoxCad  
 10-Oct-19

Material  
Matière 12 Ga Cold Rolled A1008 CS Type B (2.5mm)

Color  
Couleur Asa-61 Grey

Finish  
Fini Smooth

Description 9412DD 72" x 72" x 24" Assembly

Part Number Numéro Pièce	Rev.	1
9412DD727224	0	2

SEE BILL OF MATERIAL ON LAST PAGE

This drawing is confidential and must not be reproduced or used without the consent of EXM

Ce dessin est confidentiel et ne doit pas être reproduit ou utilisé sans le consentement de EXM

NOTE	
ITEM	DESCRIPTION
1	NEMA 4/12 Enclosure
2	C/W Standard ground studs on box and cover
3	W/O Standard door stiffener
4	W/O Inner panel
5	C/W Standard inner panel mounting struts
6	C/W Struts installed (Included)
7	C/W Eyebolts

No.	Revisions	Date	By/Par

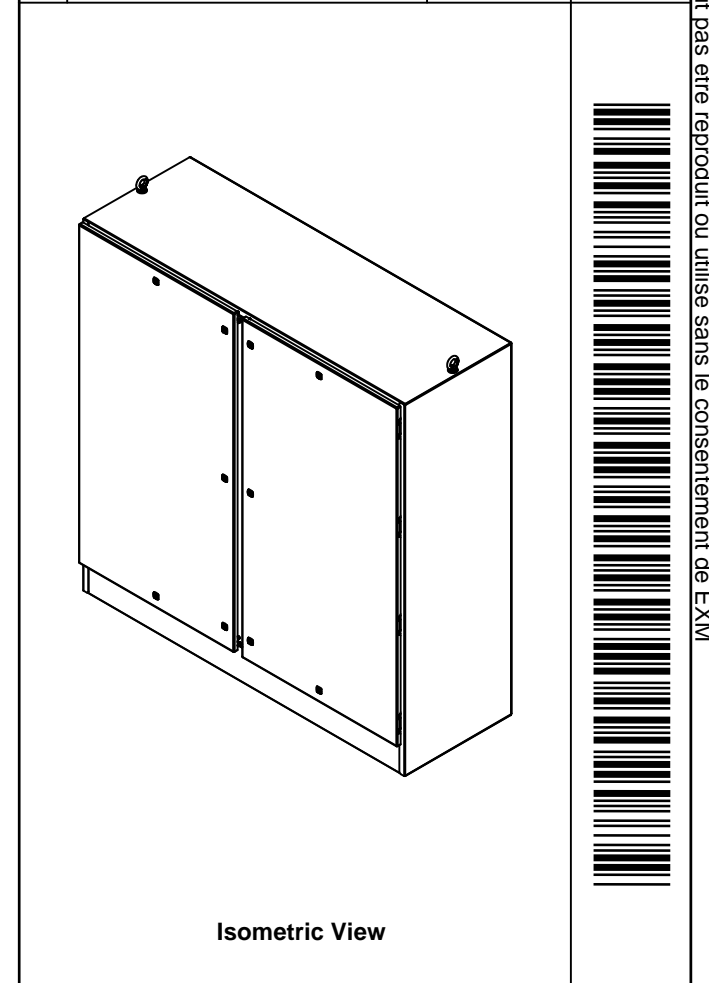

PACKING		
ITEM	QTY	DESCRIPTION
Cardboard sleeve	2	Top and Bottom
Cardboard strip	2	Between back of enclosure and inner panel
Plastic bag	1	To protect cover surface and inside gasket
Cardboard corner	4	To reinforced for the plastic strap tightening
Plastic strap - Black	2	To Squeeze 2 cardboard sleeve together
Packaging label	3	White label with PN
Plastic strap- Green	2	To secure the enclosure to the wood pallet
Wood Pallet	1	2" deeper and 3" larger than enclosure size

1	880INTI	2	880 INTI - Interlock Post Kit
1	880EB14	2	Eye Bolt M14 (Pack of 2)
1	9412DD727224FD	0	9412DD 72" x 72" Master Door
1	9412DD727224LD	0	9412DD 72" x 72" Slave Door
1	9412DD727224B	0	9412DD 72" x 72" x 24" Body
2	9412DD727224GP	0	9412DD Gland Plate
8	STK-Q-04050-10	8	M6 x 10mm Hexagon Socket Head Machine Screw with Nyseal
Qty	Part Number	Rev	Description
Parts List			

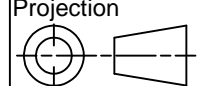
 Tél: (450) 979-4373 Fax: (450) 979-4626 <a href="http://www.exmweb.com">www.exmweb.com</a>		Flatness Aplatissement Max 3.0mm Projection 
Customer Client	Date	
Drawn By Dessiné Par	BoxCad: BoxCad	Date 10-Oct-19
Material Matière	12 Ga Cold Rolled A1008 CS Type B (2.5mm)	
Color Couleur	Asa-61 Grey	Finish Fini Smooth
Description	Detail Rev.	
9412DD 72" x 72" x 24" Assembly		
Part Number Numéro Pièce	Rev.	2
<b>9412DD727224</b>	<b>0</b>	<b>2</b>

This drawing is confidential and must not be reproduced or used without the consent of EXM

Ce dessin est confidentiel et ne doit pas être reproduit ou utilisé sans le consentement de EXM

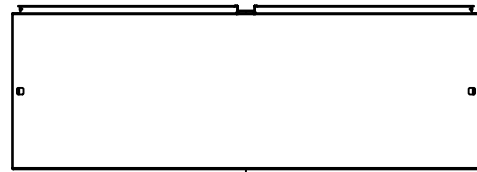

TOP

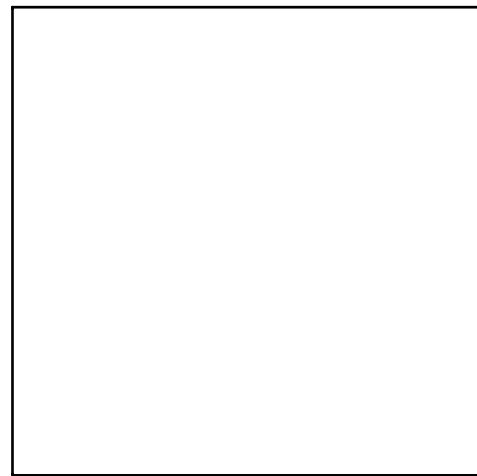

BACK

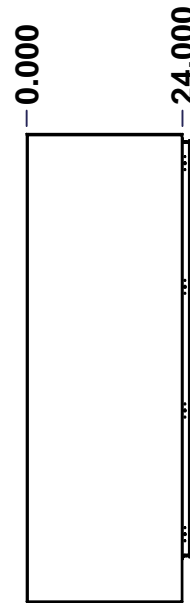

LEFT

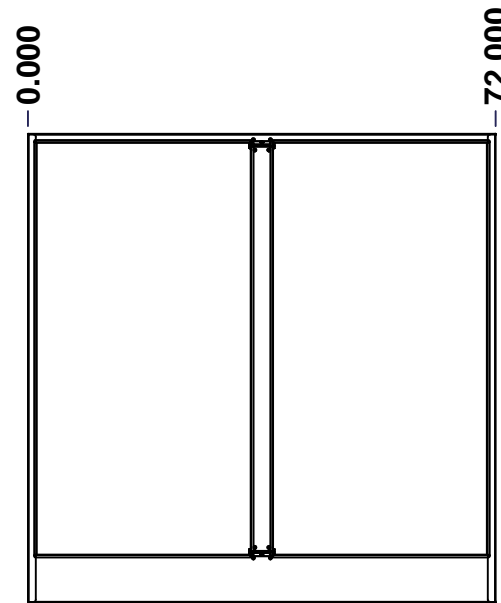

FRONT

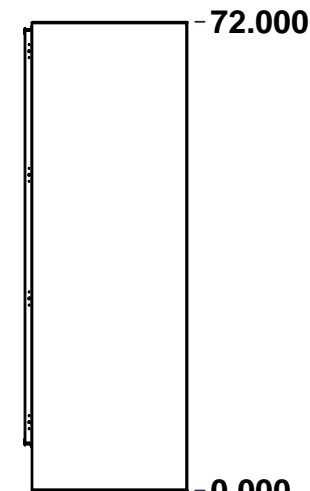

RIGHT



BOTTOM

No.	Revisions	Date	By/Par

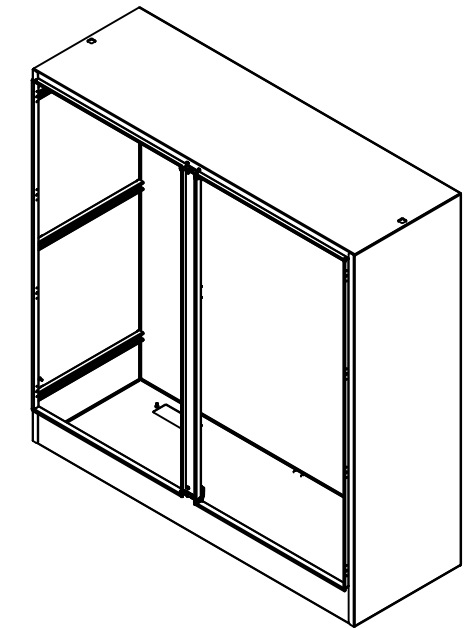

Isometric View



Tél: (450) 979-4373  
 Fax: (450) 979-4626  
[www.exmweb.com](http://www.exmweb.com)

Flatness  
Aplatissement

Max 3.0mm

Projection

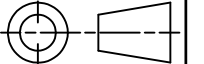

Customer Client	Date
Drawn By Dessiné Par BoxCad: BoxCad	Date 10-Oct-19
Material Matière 12 Ga Cold Rolled A1008 CS Type B (2.5mm)	
Color Couleur Asa-61 Grey	Finish Fini Smooth
Description 9412DD 72" x 72" x 24" Body	Detail Rev.
Part Number Numéro Pièce <b>9412DD727224B</b>	Rev. 1 <b>0</b> 2

SEE BILL OF MATERIAL ON LAST PAGE

This drawing is confidential and must not be reproduced or used without the consent of EXM

Ce dessin est confidentiel et ne doit pas être reproduit ou utilisé sans le consentement de EXM

STANDARD FEATURES ARE NOT LISTED IN THIS HOLE TABLE			
HOLE TABLE - TOP VIEW (CUSTOM FEATURE ONLY)			
CUT-OUT	XDIM	YDIM	DESCRIPTION
1	53.911	19.911	Struts CR400 27.500" (Inside)
2	17.911	19.911	Struts CR400 27.500" (Inside)
3	53.911	19.911	STUDS M6 x 10mm (Inside)
4	43.161	19.911	STUDS M6 x 10mm (Inside)
5	64.661	19.911	STUDS M6 x 10mm (Inside)
6	17.911	19.911	STUDS M6 x 10mm (Inside)
7	7.161	19.911	STUDS M6 x 10mm (Inside)
8	28.661	19.911	STUDS M6 x 10mm (Inside)

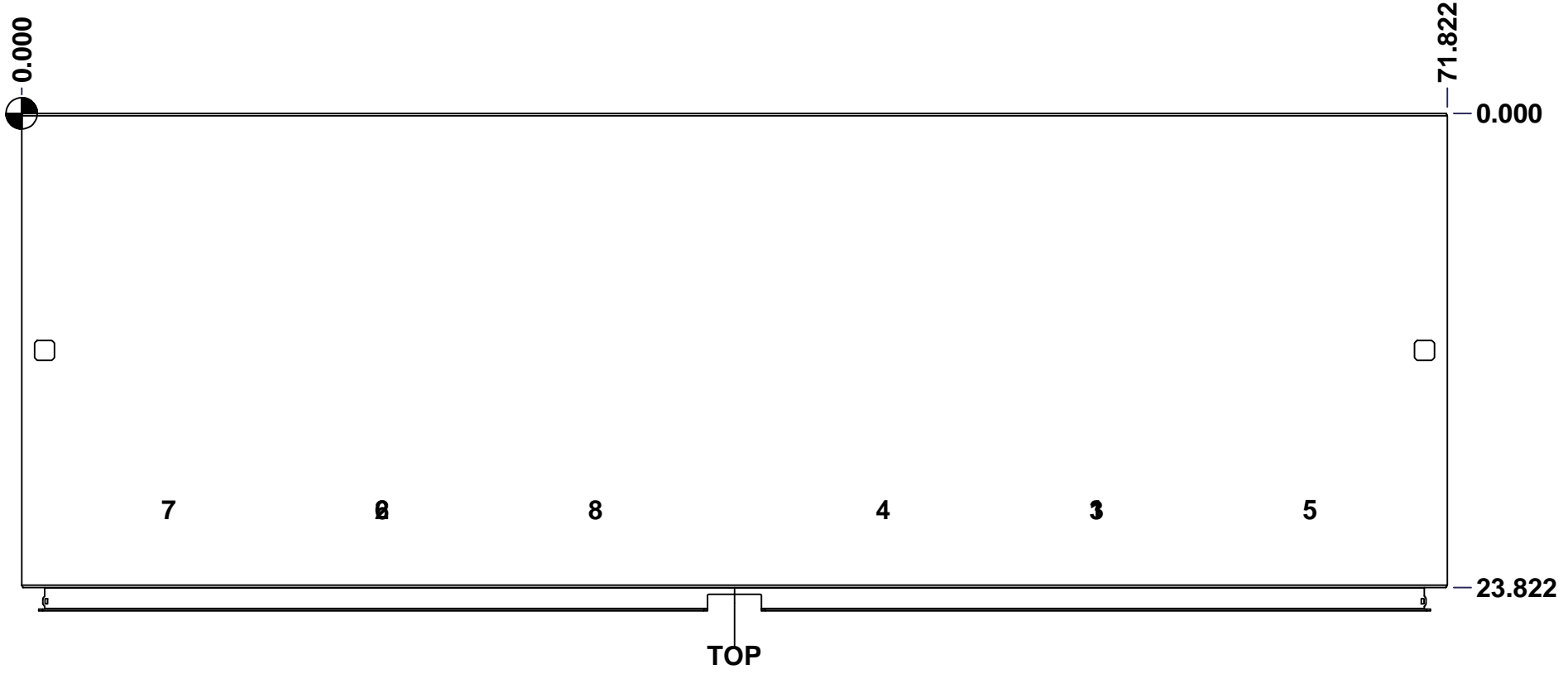

	Description	Status	
	9412DD 72" x 72" x 24" Body	Released	
	Part Number Numéro Pièce	Rev.	
	<b>9412DD727224B</b>	<b>0</b>	2 / 7

This drawing is confidential and must not be reproduced or used without the consent of EXM

Ce dessin est confidentiel et ne doit pas être reproduit ou utilisé sans le consentement de EXM

**STANDARD FEATURES ARE NOT LISTED IN THIS HOLE TABLE**

**HOLE TABLE - RIGHT VIEW (CUSTOM FEATURE ONLY)**

CUT-OUT	XDIM	YDIM	DESCRIPTION
1	22.411	11.286	GND STUD M6 x 16mm (Inside)
2	3.161	67.036	STUDS M6 x 10mm (Inside)
3	20.661	67.036	STUDS M6 x 10mm (Inside)
4	11.911	67.036	STUDS M6 x 10mm (Inside)
5	3.161	8.786	STUDS M6 x 10mm (Inside)
6	20.661	8.786	STUDS M6 x 10mm (Inside)
7	11.911	8.786	STUDS M6 x 10mm (Inside)
8	3.161	37.911	STUDS M6 x 10mm (Inside)
9	20.661	37.911	STUDS M6 x 10mm (Inside)
10	11.911	37.911	STUDS M6 x 10mm (Inside)

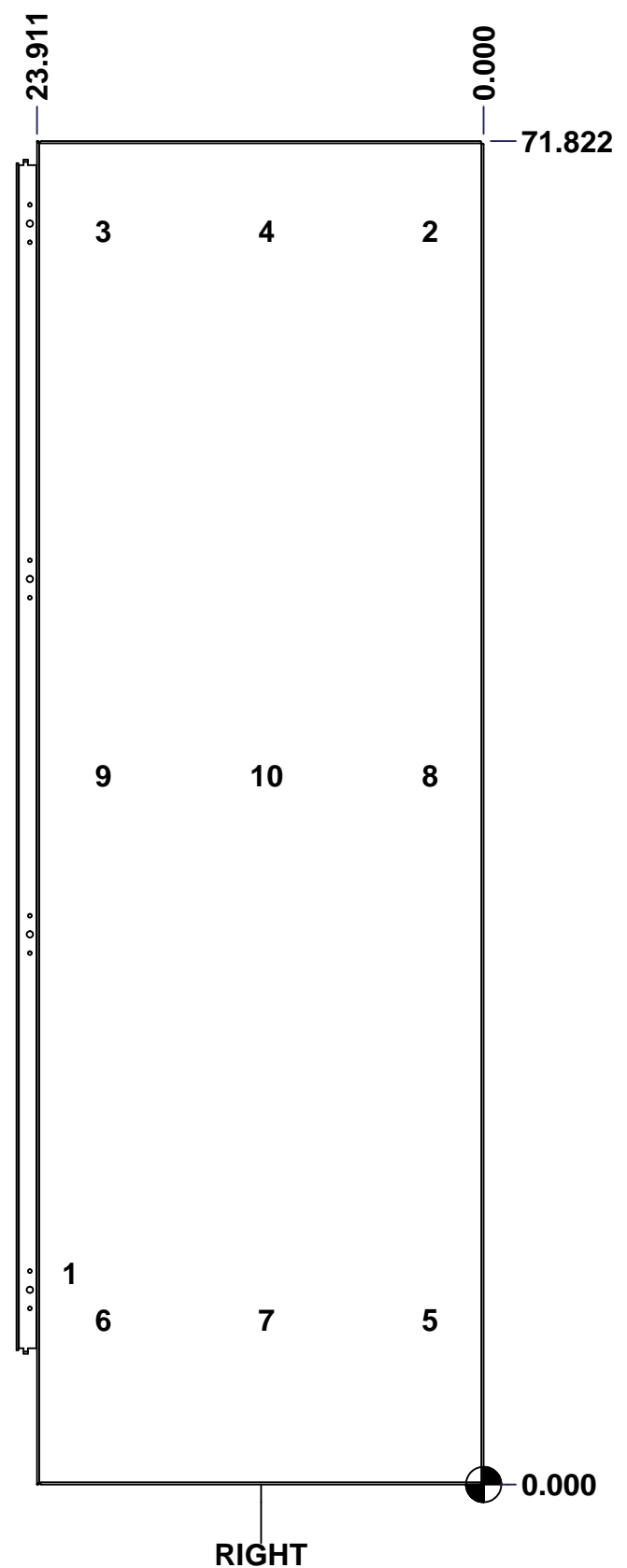

	Description	Status
	9412DD 72" x 72" x 24" Body	Released
	Part Number Numéro Pièce	Rev.
	<b>9412DD727224B</b>	<b>0</b>
		3
		7

This drawing is confidential and must not be reproduced or used without the consent of EXM

Ce dessin est confidentiel et ne doit pas être reproduit ou utilisé sans le consentement de EXM

STANDARD FEATURES ARE NOT LISTED IN THIS HOLE TABLE			
HOLE TABLE - BOTTOM VIEW (CUSTOM FEATURE ONLY)			
CUT-OUT	XDIM	YDIM	DESCRIPTION
1	7.286	3.411	GP STUD M6 x 16mm (Inside)
2	16.536	3.411	GP STUD M6 x 16mm (Inside)
3	55.286	3.411	GP STUD M6 x 16mm (Inside)
4	64.536	3.411	GP STUD M6 x 16mm (Inside)

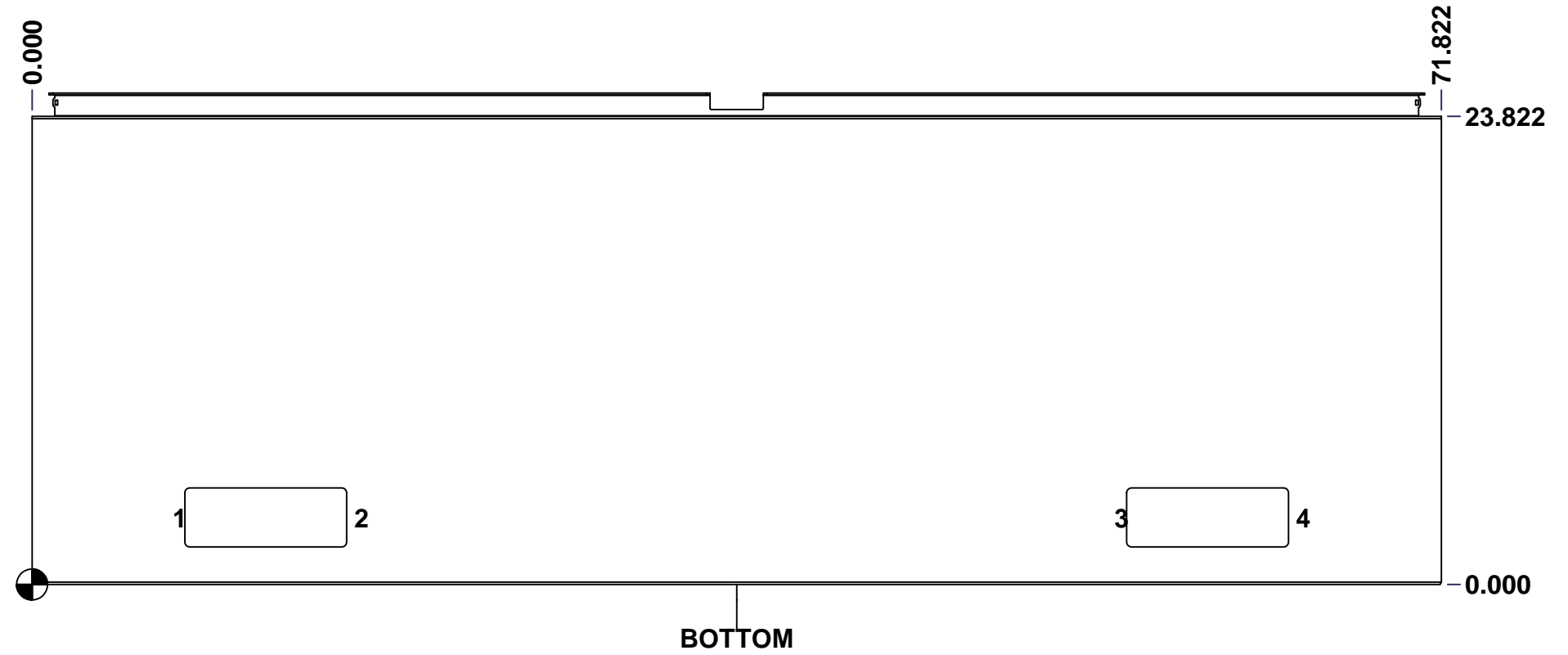

	Description	Status	
	9412DD 72" x 72" x 24" Body	Released	
	Part Number Numéro Pièce	Rev.	
	<b>9412DD727224B</b>	<b>0</b>	4 / 7

This drawing is confidential and must not be reproduced or used without the consent of EXM

Ce dessin est confidentiel et ne doit pas être reproduit ou utilisé sans le consentement de EXM

**STANDARD FEATURES ARE NOT LISTED IN THIS HOLE TABLE**

**HOLE TABLE - LEFT VIEW (CUSTOM FEATURE ONLY)**

CUT-OUT	XDIM	YDIM	DESCRIPTION
1	22.411	11.286	GND STUD M6 x 16mm (Inside)
2	3.161	67.036	STUDS M6 x 10mm (Inside)
3	20.661	67.036	STUDS M6 x 10mm (Inside)
4	11.911	67.036	STUDS M6 x 10mm (Inside)
5	3.161	8.786	STUDS M6 x 10mm (Inside)
6	20.661	8.786	STUDS M6 x 10mm (Inside)
7	11.911	8.786	STUDS M6 x 10mm (Inside)
8	3.161	37.911	STUDS M6 x 10mm (Inside)
9	20.661	37.911	STUDS M6 x 10mm (Inside)
10	11.911	37.911	STUDS M6 x 10mm (Inside)

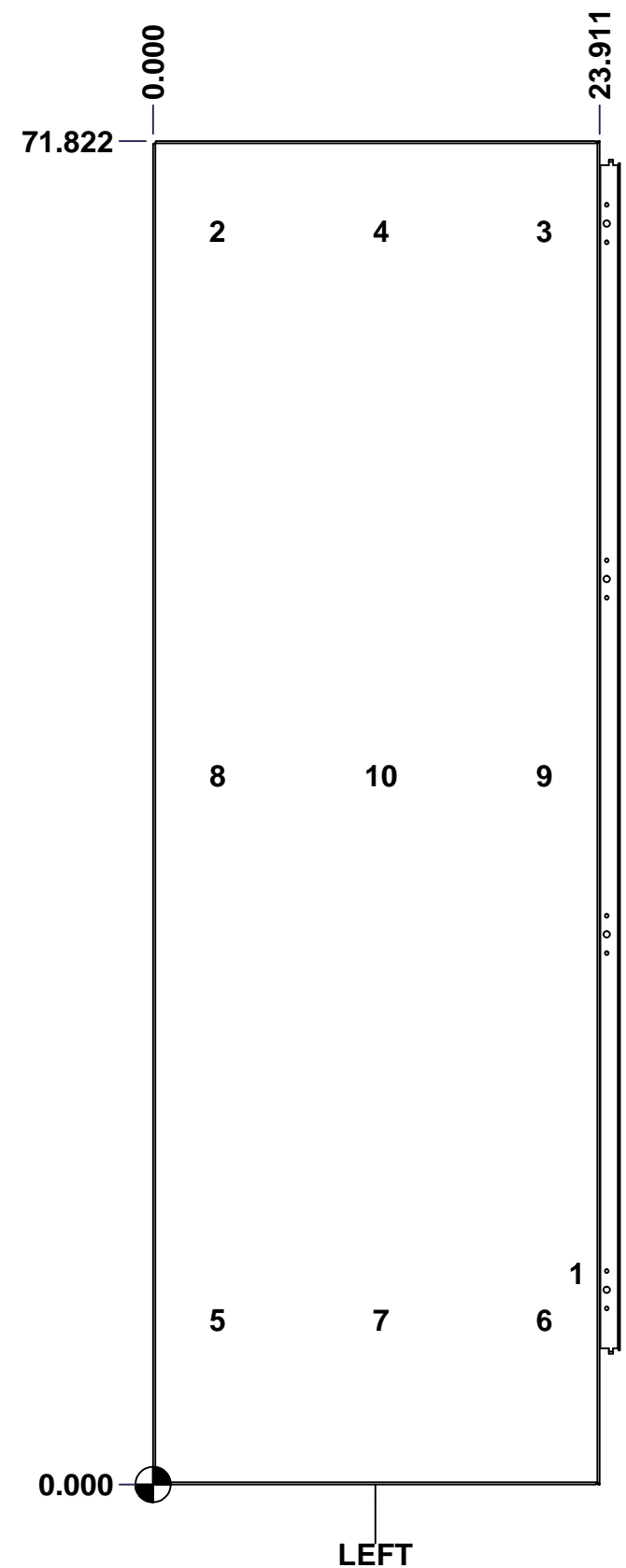

	Description	Status
	9412DD 72" x 72" x 24" Body	Released
	Part Number Numéro Pièce	Rev.
	<b>9412DD727224B</b>	<b>0</b>
		5 / 7

This drawing is confidential and must not be reproduced or used without the consent of EXM

Ce dessin est confidentiel et ne doit pas être reproduit ou utilisé sans le consentement de EXM

STANDARD FEATURES ARE NOT LISTED IN THIS HOLE TABLE			
HOLE TABLE - CENTER VIEW (CUSTOM FEATURE ONLY)			
CUT-OUT	XDIM	YDIM	DESCRIPTION
1	0.748	38.210	INTERLOCK STUD M6 x 16mm (Inside)
2	0.748	40.336	INTERLOCK STUD M6 x 16mm (Inside)
3	2.717	38.210	INTERLOCK STUD M6 x 16mm (Inside)
4	2.717	40.336	INTERLOCK STUD M6 x 16mm (Inside)

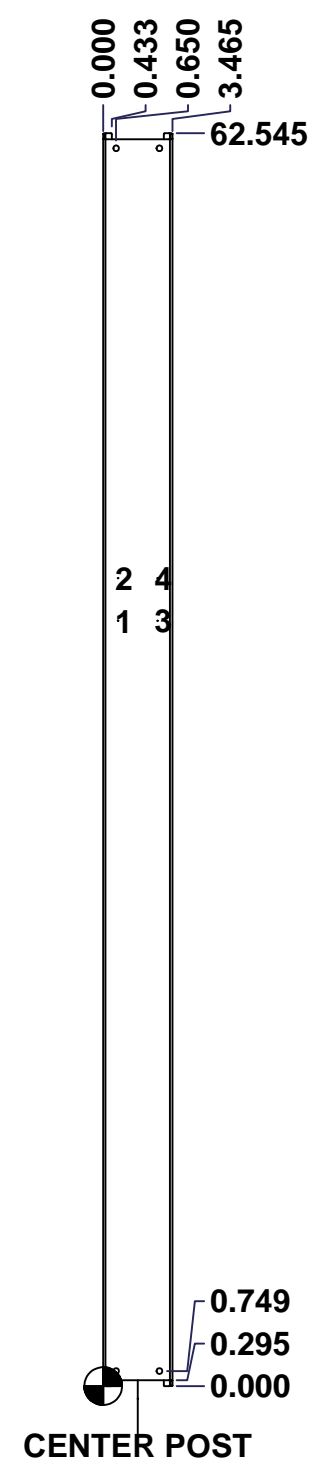

	Description	Status	
	9412DD 72" x 72" x 24" Body	Released	
	Part Number Numéro Pièce	Rev.	
	<b>9412DD727224B</b>	<b>0</b>	6 7



This drawing is confidential and must not be reproduced or used without the consent of EXM

Ce dessin est confidentiel et ne doit pas être reproduit ou utilisé sans le consentement de EXM

No.	Revisions	Date	By/Par

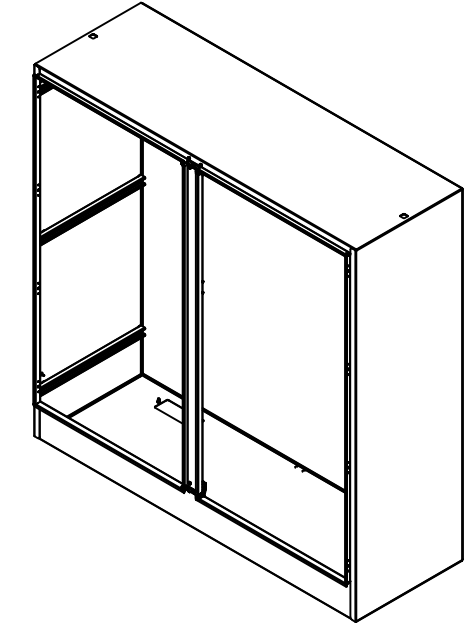

Isometric View

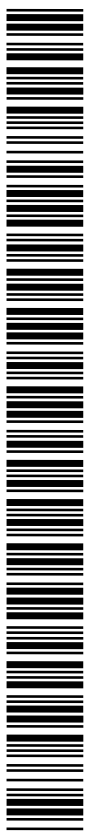

24	STK-Q-16030	0	Stud M6 x 10mm
1	STK-P-02400S	0	Powder Paint (Asa-61 Grey / Smooth)
6	STK-Q-52250-24	2	Sasco Strut S5 (23.500" Long)
4	STK-Q-16055	1	M6 x 18mm Stud (No Paint Cap Required)
1	STK-A-75454	3	Center Post - Sealing Block with Latch Assembly (Large)
1	9412DD727224CP-P	0	9412DD 72" Center Post Part
1	9412DD727224BT-P	0	9412DD 72" x 24" Bottom Part
1	9412DD727224T-P	0	9412DD 72" x 24" Top Part
1	9412DD727224RS-P	0	9412DD 72" x 72" Right Part
1	9412DD727224LS-P	0	9412DD 72" x 72" Left Part
1	9412DD727224B-P	0	9412DD 72" x 72" Back Part
2	CR400MS_27.5	0	Commercial Roll Mild Steel (27.5in long)
24	STK-Q-07220	1	M6 Nylon Insert Lock Nut
6	STK-Q-16080	0	Ground Stud M6 x 16mm
Qty	Part Number	Rev	Description

Parts List

Tél: (450) 979-4373  
 Fax: (450) 979-4626  
[www.exmweb.com](http://www.exmweb.com)

Flatness  
Aplatissement  
Max 3.0mm  
Projection

Customer Client  
 Drawn By / Dessiné Par: BoxCad: BoxCad

Date: 10-Oct-19

Material Matière: 12 Ga Cold Rolled A1008 CS Type B (2.5mm)

Color Couleur: Asa-61 Grey

Finish Fini: Smooth

Description: 9412DD 72" x 72" x 24" Body

Part Number / Numéro Pièce:  
**9412DD727224B**

Rev. 2  
**0**

This drawing is confidential and must not be reproduced or used without the consent of EXM

Ce dessin est confidentiel et ne doit pas être reproduit ou utilisé sans le consentement de EXM

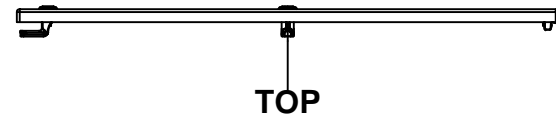

TOP

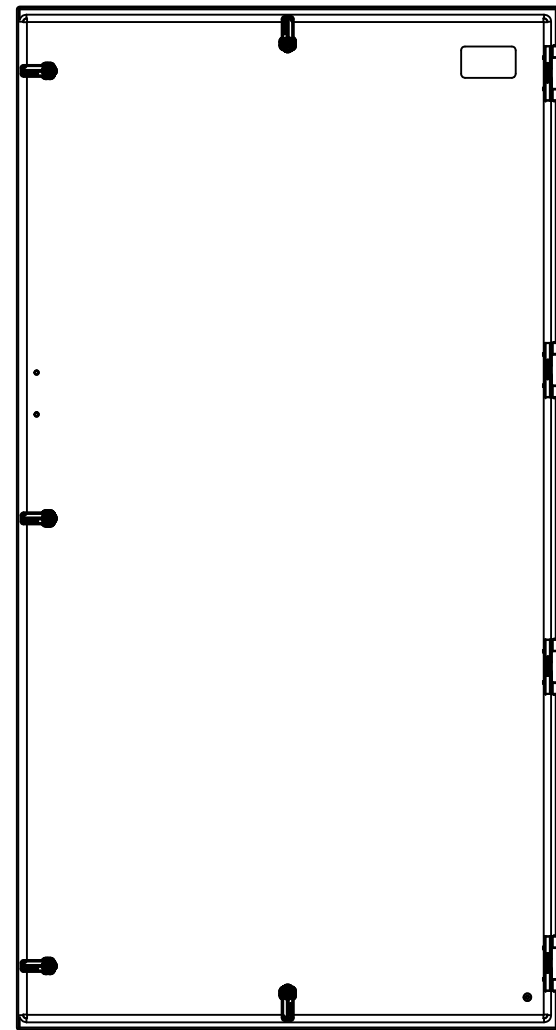

BACK



BOTTOM

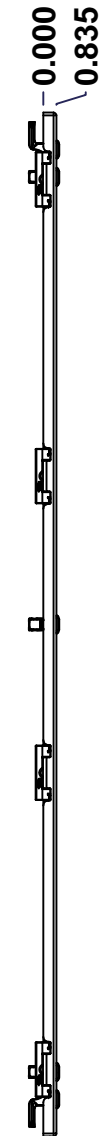

LEFT

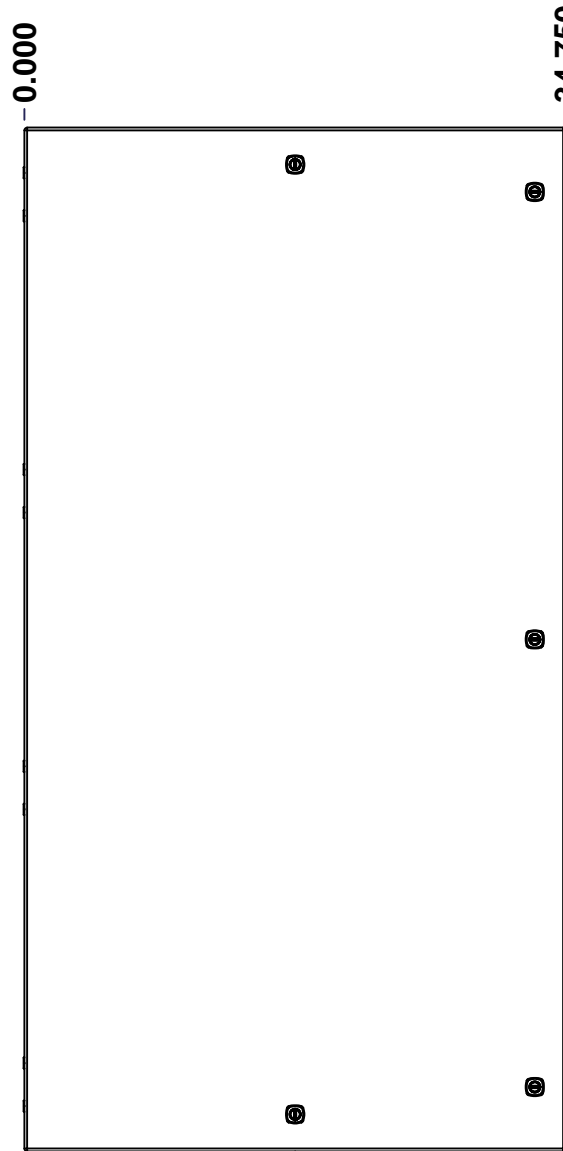

FRONT

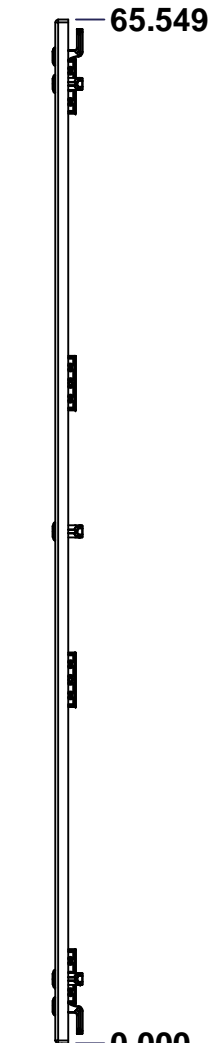

RIGHT

No.	Revisions	Date	By/Par

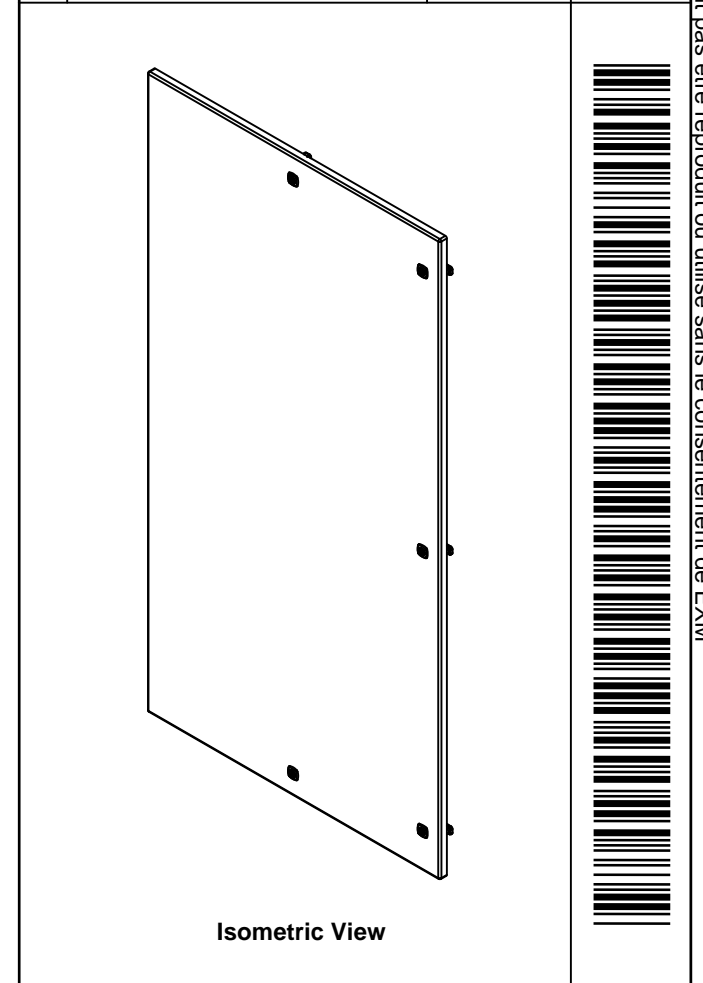

Tél: (450) 979-4373 Fax: (450) 979-4626 <a href="http://www.exmweb.com">www.exmweb.com</a>		Flatness Aplatissement	
		Max 3.0mm	
Customer Client		Date	
Drawn By Dessiné Par BoxCad: BoxCad		Date 10-Oct-19	
Material Matière 12 Ga Cold Rolled A1008 CS Type B (2.5mm)			
Color Couleur Asa-61 Grey		Finish Fini Smooth	
Description 9412DD 72" x 72" Slave Door			Detail Rev.
Part Number Numéro Pièce <b>9412DD727224LD</b>		Rev. <b>0</b>	1 3

SEE BILL OF MATERIAL ON LAST PAGE

This drawing is confidential and must not be reproduced or used without the consent of EXM

Ce dessin est confidentiel et ne doit pas être reproduit ou utilisé sans le consentement de EXM

**STANDARD FEATURES ARE NOT LISTED IN THIS HOLE TABLE**

**HOLE TABLE - FRONT VIEW (CUSTOM FEATURE ONLY)**

CUT-OUT	XDIM	YDIM	DESCRIPTION
1	32.750	61.430	LOCK 889 SCQ4-SL @ 0.0°
2	32.750	32.774	LOCK 889 SCQ4-SL @ 0.0°
3	32.750	4.118	LOCK 889 SCQ4-SL @ 0.0°
4	17.375	63.180	LOCK 889 SCQ4-SL @ 90.0°
5	17.375	2.368	LOCK 889 SCQ4-SL @ 270.0°
6	2.000	2.118	GND STUD M6 x 16mm (Inside)
7	33.489	39.435	STUDS M6 x 18mm (Inside)
8	33.489	42.113	STUDS M6 x 18mm (Inside)

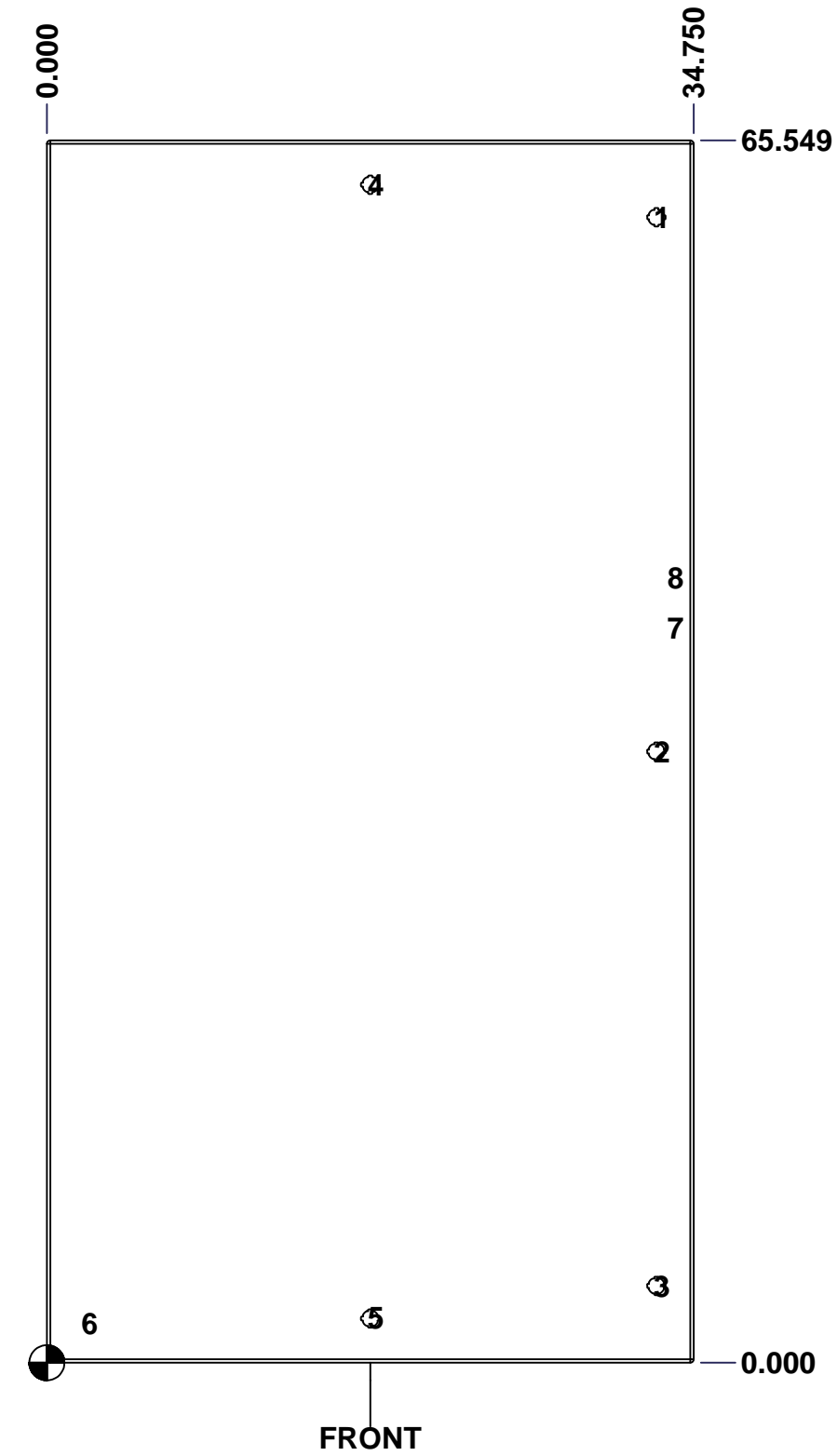

FRONT

	Description	Status	
	9412DD 72" x 72" Slave Door	(NULL)	
	Part Number Numéro Pièce	Rev.	
	<b>9412DD727224LD</b>	<b>0</b>	2 3

This drawing is confidential and must not be reproduced or used without the consent of EXM

Ce dessin est confidentiel et ne doit pas être reproduit ou utilisé sans le consentement de EXM

No.	Revisions	Date	By/Par

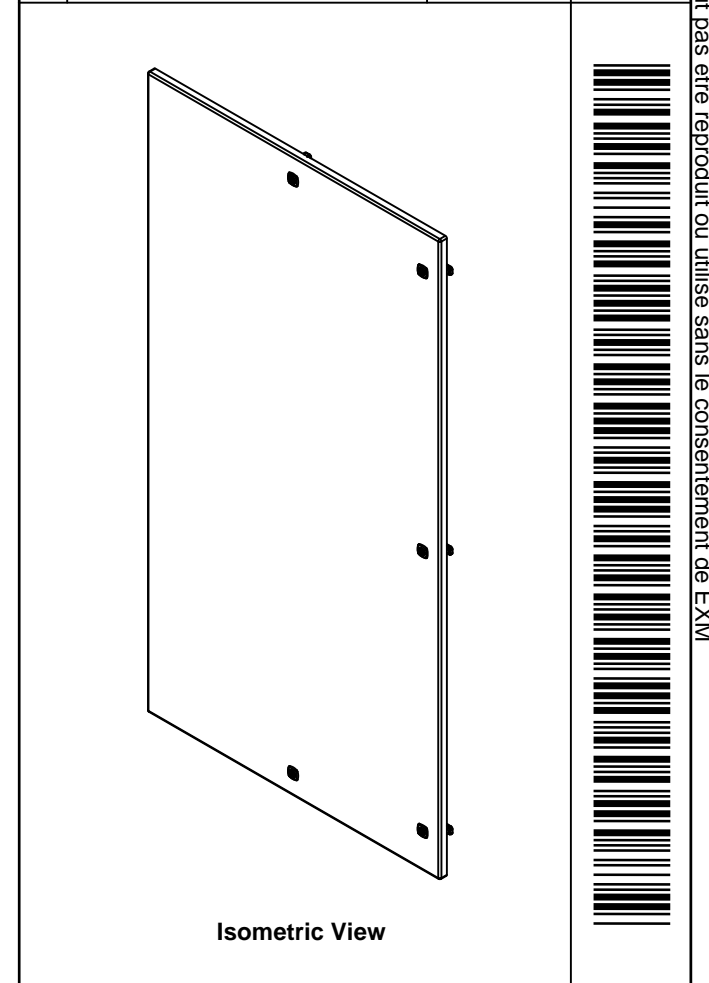

Tél: (450) 979-4373 Fax: (450) 979-4626 <a href="http://www.exmweb.com">www.exmweb.com</a>		Flatness Aplatissement Max 3.0mm Projection 
Customer Client	Date	
Drawn By / Dessiné Par: BoxCad: BoxCad	Date: 10-Oct-19	
Material / Matière: 12 Ga Cold Rolled A1008 CS Type B (2.5mm)	Color / Couleur: Asa-61 Grey	
Finish / Fini: Smooth		Detail Rev.
Description: 9412DD 72" x 72" Slave Door		Rev. 3
Part Number / Numéro Pièce: <b>9412DD727224LD</b>		0

2	STK-Q-16055	1	M6 x 18mm Stud (No Paint Cap Required)
1	STK-Q-16080	0	Ground Stud M6 x 16mm
1	9412DD727224DG	0	9412DD 72" x 72" Door Gasket
1	STK-P-02400S	0	Powder Paint (Asa-61 Grey / Smooth)
1	STK-S-00100	0	3.5" x 2" Silver Milar Flexcon Sticker
1	9412DD727224LD-P	0	9412DD 72" x 72" Slave Door Part
4	STK-K-09860	7	Cabinet Hinge with Captive Pins
5	STK-K-12580	0	9412 1/4 Turn Lock
Qty	Part Name	Rev	Description
Parts List			

This drawing is confidential and must not be reproduced or used without the consent of EXM

Ce dessin est confidentiel et ne doit pas être reproduit ou utilisé sans le consentement de EXM

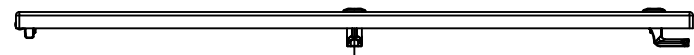

TOP

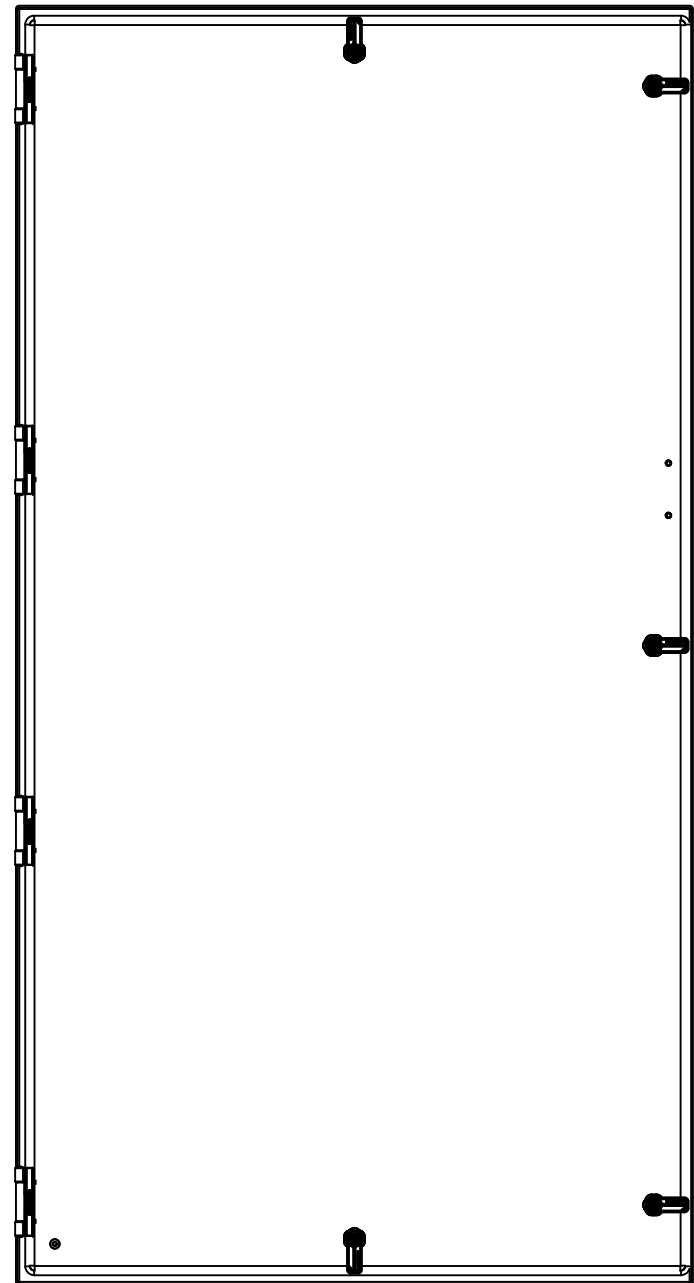

BACK



BOTTOM

0.000  
0.835

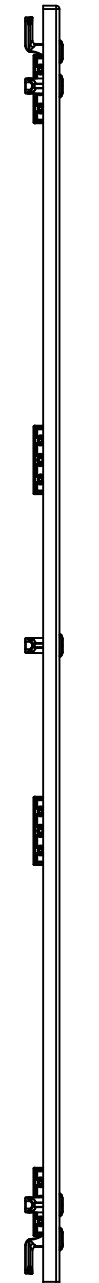

LEFT

34.750

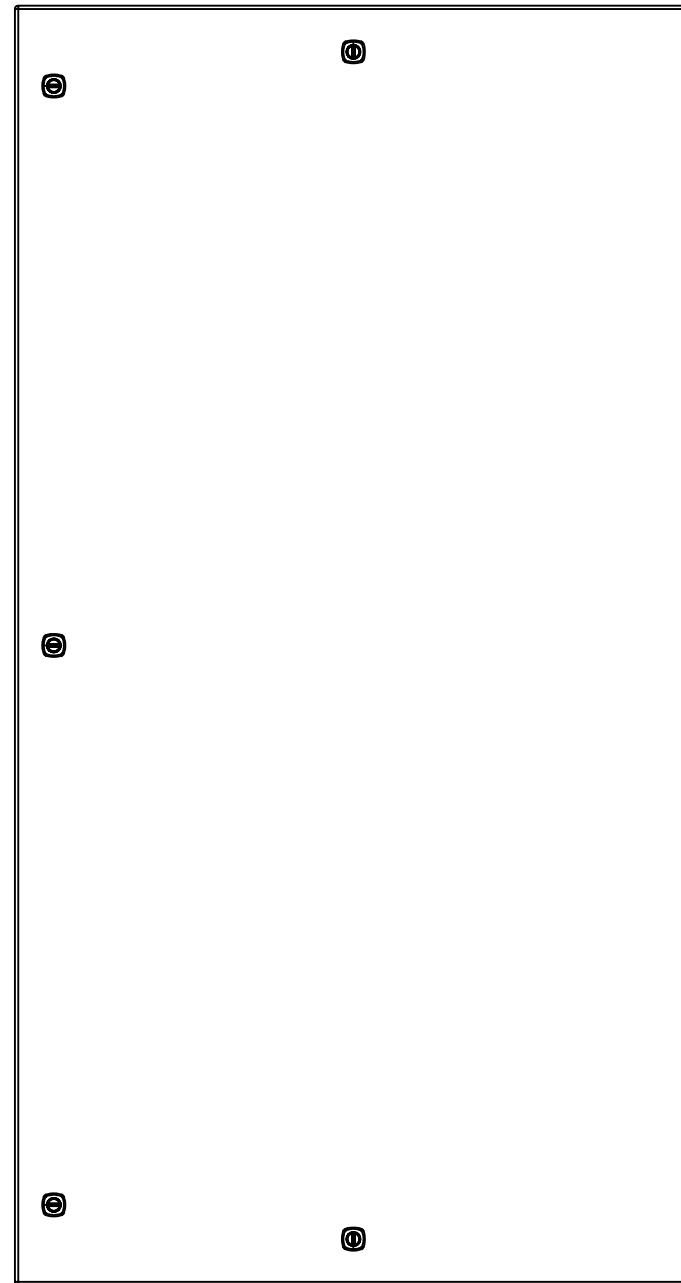

FRONT

0.000

65.549



RIGHT

0.000

No.	Revisions	Date	By/Par

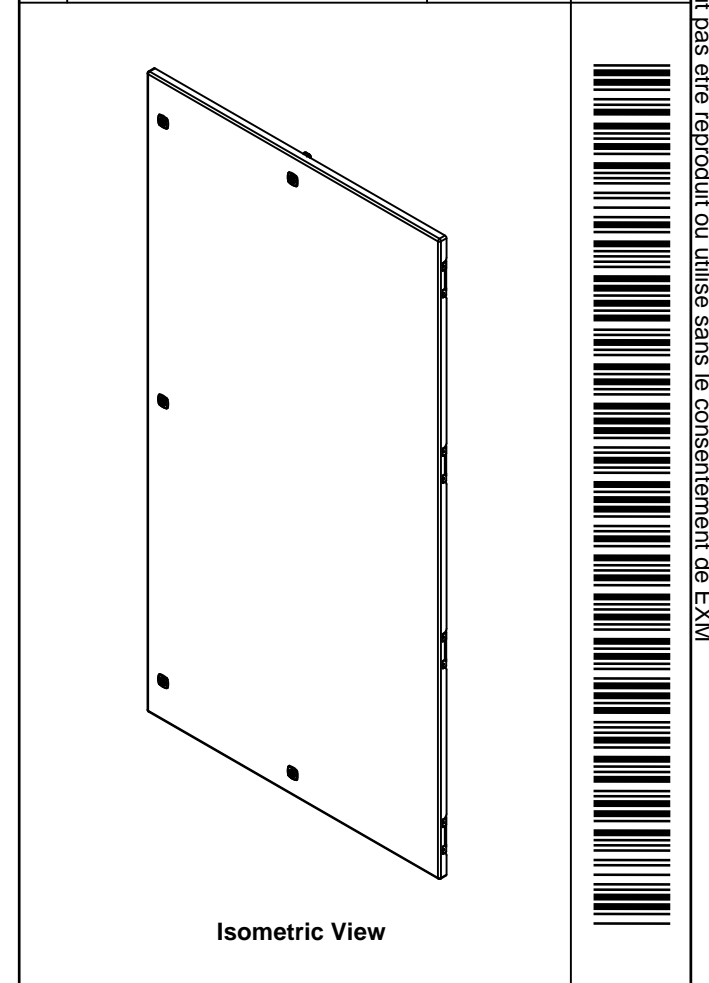

Tél: (450) 979-4373 Fax: (450) 979-4626 <a href="http://www.exmweb.com">www.exmweb.com</a>		Flatness Aplatissement	
		Max 3.0mm	
Customer Client		Date	
Drawn By Dessiné Par BoxCad: BoxCad		Date 10-Oct-19	
Material Matière 12 Ga Cold Rolled A1008 CS Type B (2.5mm)		Projection	
Color Couleur Asa-61 Grey		Finish Fini Smooth	
Description 9412DD 72" x 72" Master Door		Detail Rev.	
Part Number Numéro Pièce <b>9412DD727224FD</b>		Rev. <b>0</b>	1 3

SEE BILL OF MATERIAL ON LAST PAGE

This drawing is confidential and must not be reproduced or used without the consent of EXM

Ce dessin est confidentiel et ne doit pas être reproduit ou utilisé sans le consentement de EXM

**STANDARD FEATURES ARE NOT LISTED IN THIS HOLE TABLE**

**HOLE TABLE - FRONT VIEW (CUSTOM FEATURE ONLY)**

CUT-OUT	XDIM	YDIM	DESCRIPTION
1	2.000	2.118	GND STUD M6 x 16mm (Inside)
2	17.375	63.180	LOCK 889 SCQ4-SL @ 90.0°
3	32.750	61.430	LOCK 889 SCQ4-SL @ 180.0°
4	32.750	32.774	LOCK 889 SCQ4-SL @ 180.0°
5	32.750	4.118	LOCK 889 SCQ4-SL @ 180.0°
6	17.375	2.368	LOCK 889 SCQ4-SL @ 270.0°
7	33.489	39.435	STUDS M6 x 18mm (Inside)
8	33.489	42.113	STUDS M6 x 18mm (Inside)

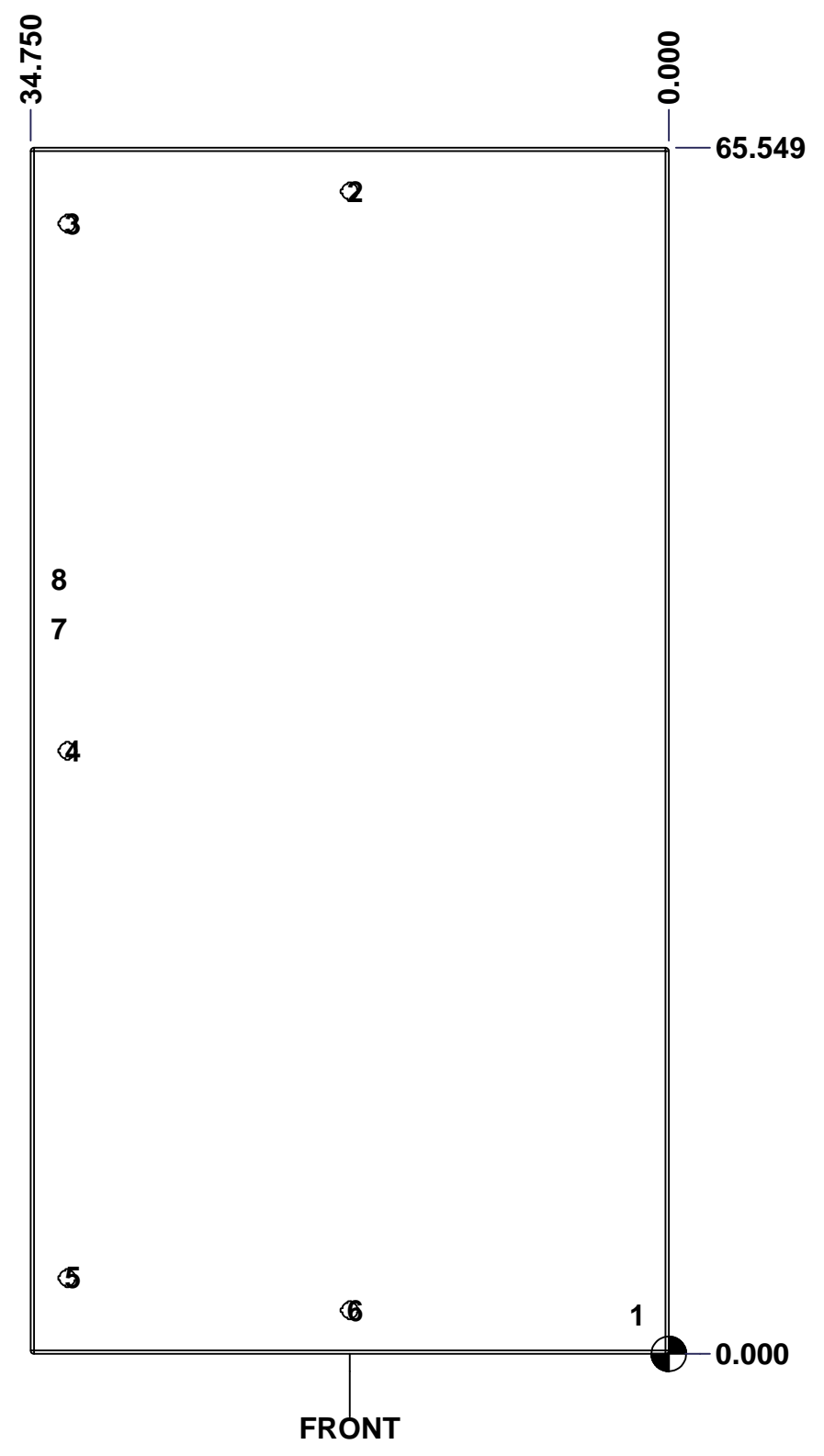

	Description	Status
	9412DD 72" x 72" Master Door	(NULL)
	Part Number Numéro Pièce	Rev.
	<b>9412DD727224FD</b>	<b>0</b>
		2
		3

This drawing is confidential and must not be reproduced or used without the consent of EXM

Ce dessin est confidentiel et ne doit pas être reproduit ou utilisé sans le consentement de EXM

No.	Revisions	Date	By/Par

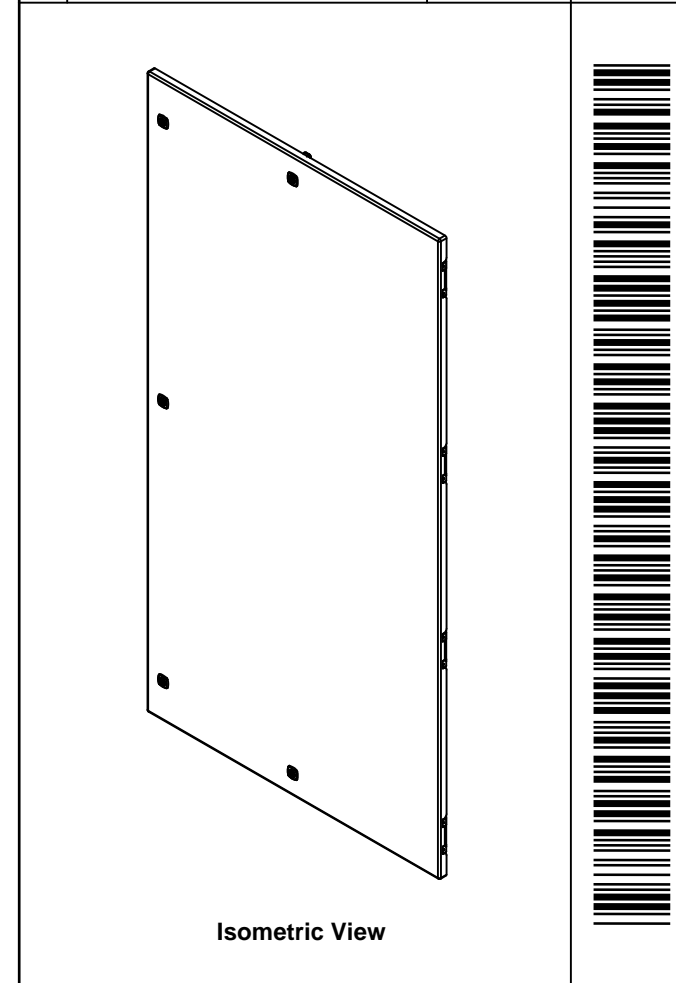

Tél: (450) 979-4373 Fax: (450) 979-4626 <a href="http://www.exmweb.com">www.exmweb.com</a>		Flatness Aplatissement	
		Max 3.0mm Projection	
Customer Client		Date	
Drawn By Dessiné Par BoxCad: BoxCad		Date 10-Oct-19	
Material Matière 12 Ga Cold Rolled A1008 CS Type B (2.5mm)			
Color Couleur Asa-61 Grey		Finish Fini Smooth	
Description 9412DD 72" x 72" Master Door			Detail Rev.
Part Number Numéro Pièce <b>9412DD727224FD</b>		Rev. <b>0</b>	3 3

2	STK-Q-16055	1	M6 x 18mm Stud (No Paint Cap Required)
1	9412DD727224DG	0	9412DD 72" x 72" Door Gasket
1	STK-Q-16080	0	Ground Stud M6 x 16mm
1	STK-P-02400S	0	Powder Paint (Asa-61 Grey / Smooth)
1	9412DD727224FD-P	0	9412DD 72" x 72" Master Door Part
4	STK-K-09860	7	Cabinet Hinge with Captive Pins
5	STK-K-12580	0	9412 1/4 Turn Lock
Qty	Part Name	Rev	Description
Parts List			

All knockouts are actual size / Les disques défonçables sont grandeur réel  
 All dimensions are before paint / Toutes les dimensions sont avant peinture

This drawing is confidential and must not be reproduced or used without the consent of EXM

Ce dessin est confidentiel et ne doit pas être reproduit ou utilisé sans le consentement de EXM

Lifting angles are the flanges of RS and LS top

Struts for light secured with stud only (No weld)

Weld inside of struts with the enclosure corner on both ends

Struts secured with M6 x 10mm studs  
 No stud: C\_Depth < 12"  
 2 studs: 12" ≤ C\_Depth < 18"  
 3 studs: C\_Depth ≥ 18"

Full depth struts length

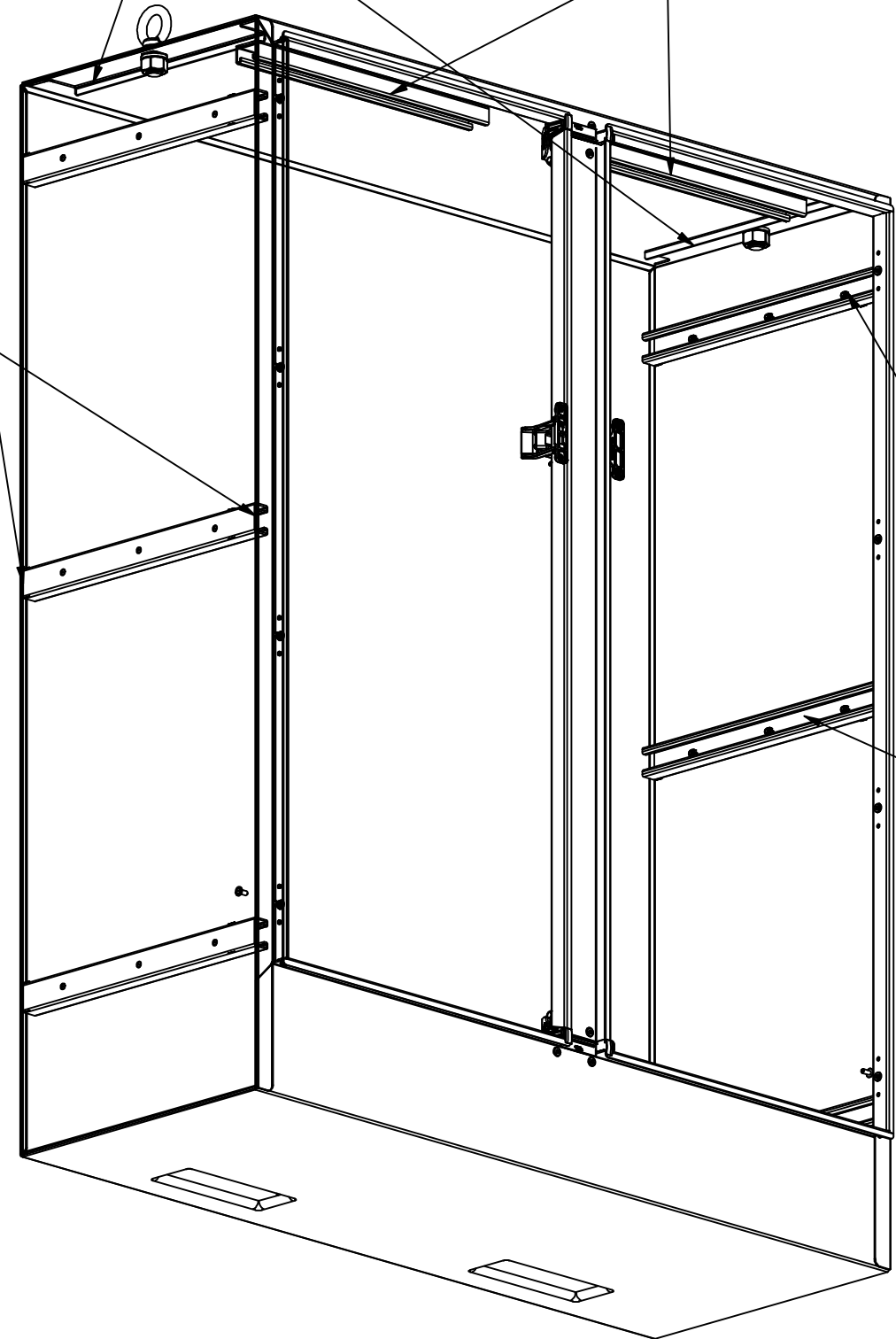

No.	Revisions	Date	By/Par

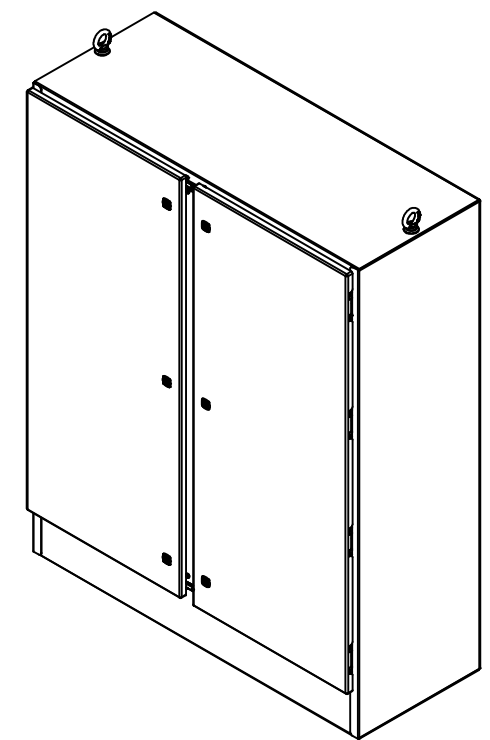

Isometric View



Tél: (450) 979-4373  
 Fax: (450) 979-4626  
[www.exmweb.com](http://www.exmweb.com)

Flatness  
 Aplatissement  
 Max 0.0mm  
 Projection

Customer Client	Date	
Drawn By / Dessiné Par: PatrickD	Date	3/9/2020
Material / Matière	N/A	
Color / Couleur	N/A	Finish / Fini: N/A
Description	9412DD Welding Detail	
Part Number / Numéro Pièce	9412DD_WELDING_DETAIL	Detail Rev. 1
	Rev. 0	1