

This drawing is confidential and must not be reproduced or used without the consent of EXM

Ce dessin est confidentiel et ne doit pas être reproduit ou utilisé sans le consentement de EXM

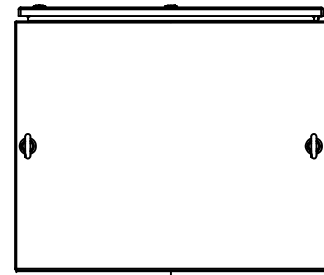

TOP

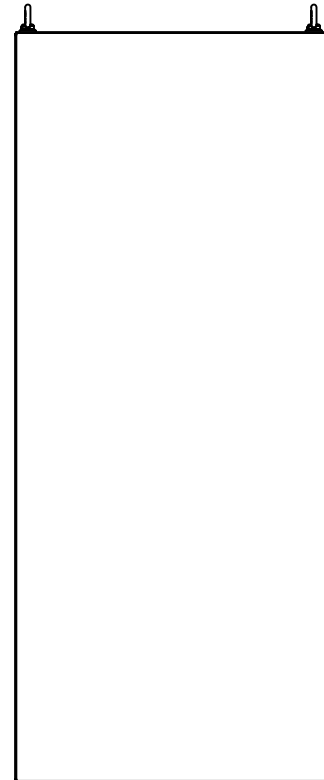

BACK

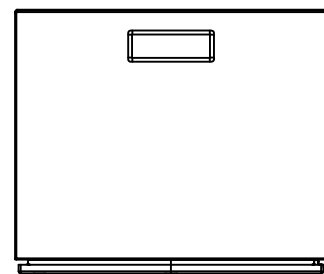

BOTTOM

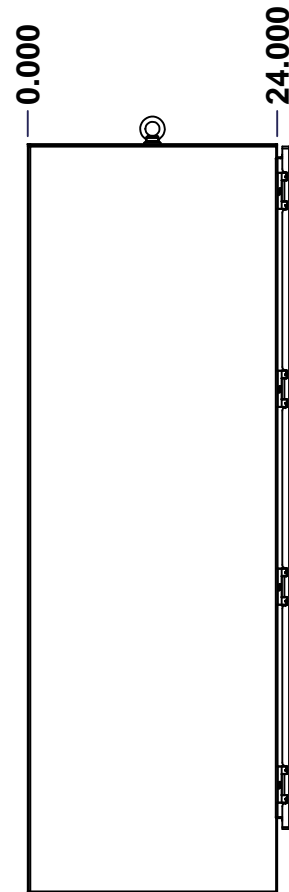

LEFT

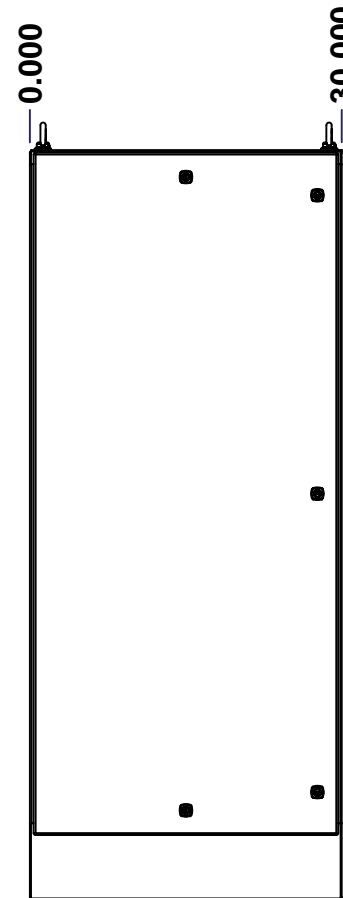

FRONT

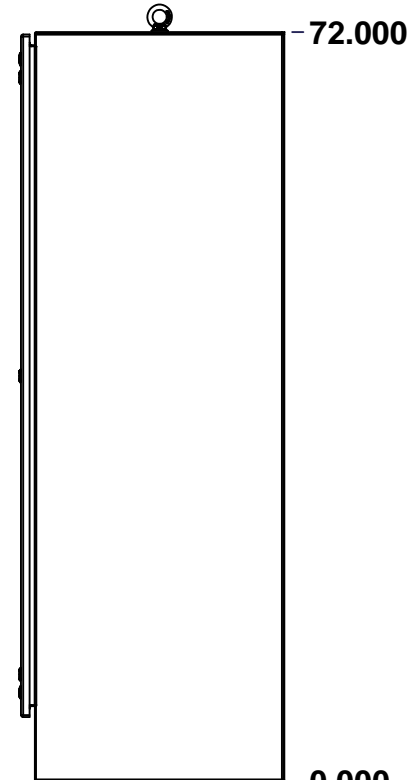

RIGHT

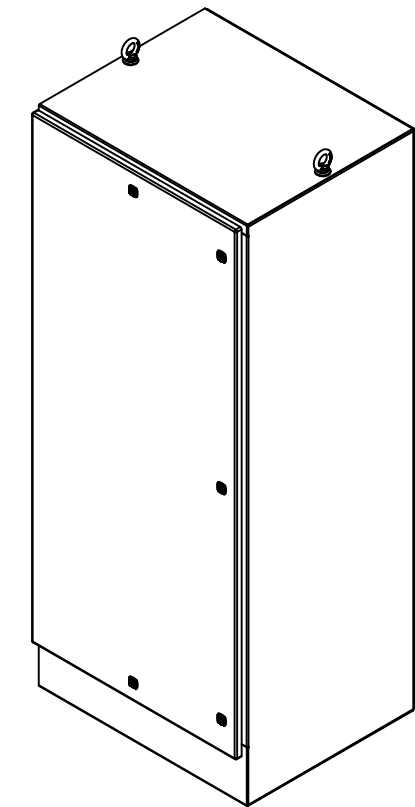

Isometric View



**GRAIN DIRECTION:
TOP/BOTTOM: HORIZONTAL
LEFT/RIGHT/BACK/FRONT: VERTICAL**

SEE BILL OF MATERIAL ON LAST PAGE

No.	Revisions	Date	By/Par

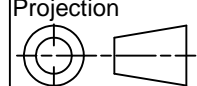
 Tél: (450) 979-4373 Fax: (450) 979-4626 www.exmweb.com		Flatness Aplatissement Max 3.0mm Projection 
Customer Client	Date	Date
Drawn By Dessiné Par	BoxCad: BoxCad	28-Jan-21
Material Matière	12 Ga Stainless Steel 304 (2.5mm)	
Color Couleur	Unpainted	Finish Fini: Brushed
Description	9412SS 72" x 30" x 24" Assembly	
Part Number Numéro Pièce	9412SS723024	Detail Rev. Rev. 1 0 2

This drawing is confidential and must not be reproduced or used without the consent of EXM

Ce dessin est confidentiel et ne doit pas être reproduit ou utilisé sans le consentement de EXM

NOTE	
ITEM	DESCRIPTION
1	NEMA 4X Enclosure
2	C/W Standard ground studs on box and cover
3	W/O Standard door stiffener
4	W/O Inner panel
5	C/W Standard inner panel mounting struts
6	C/W Eyebolts
7	C/W Struts installed (Included)

No.	Revisions	Date	By/Par

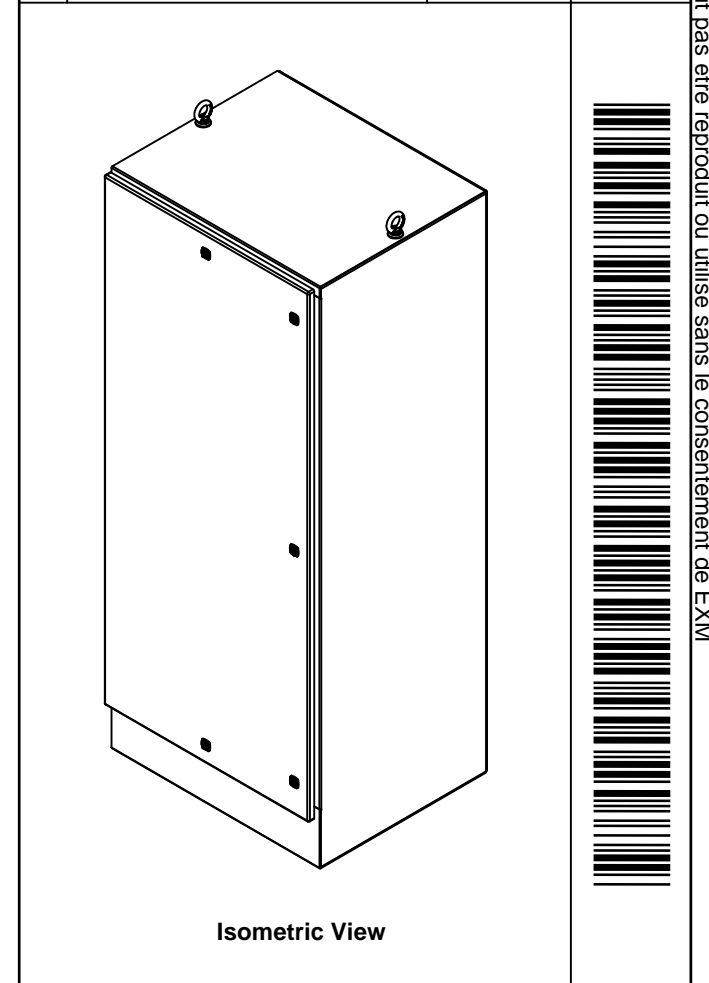

PACKING		
ITEM	QTY	DESCRIPTION
Cardboard sleeve	2	Top and Bottom
Cardboard strip	2	Between back of enclosure and inner panel
Plastic bag	1	To protect cover surface and inside gasket
Cardboard corner	4	To reinforced for the plastic strap tightening
Plastic strap - Black	2	To Squeeze 2 cardboard sleeve together
Packaging label	3	White label with PN
Plastic strap- Green	2	To secure the enclosure to the wood pallet
Wood Pallet	1	2" deeper and 3" larger than enclosure size

Qty	Part Number	Rev	Description
1	9412SS723024GP	0	9412SS Gland Plate
1	880EB14SS	2	Stainless Steel Eye Bolt M14 (Pack of 2)
1	9412SS723024C	0	9412SS 72" x 30" Cover
1	9412SS723024B	0	9412SS 72" x 30" x 24" Body
4	STK-Q-04051-10	8	M6 Hexagon Socket Head Machine Screw with Nyseal
Parts List			

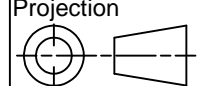
 Tél: (450) 979-4373 Fax: (450) 979-4626 www.exmweb.com		Flatness Aplatissement Max 3.0mm Projection 
Customer Client	Date	
Drawn By Dessiné Par	BoxCad: BoxCad	Date 28-Jan-21
Material Matière	12 Ga Stainless Steel 304 (2.5mm)	
Color Couleur	Unpainted	Finish Fini Brushed
Description	Detail Rev.	
9412SS 72" x 30" x 24" Assembly		
Part Number Numéro Pièce	Rev.	2
9412SS723024	0	2

This drawing is confidential and must not be reproduced or used without the consent of EXM

Ce dessin est confidentiel et ne doit pas être reproduit ou utilisé sans le consentement de EXM

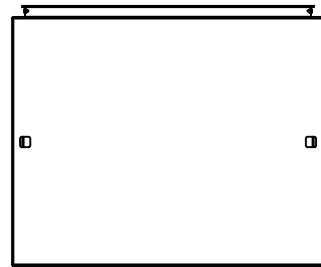

TOP

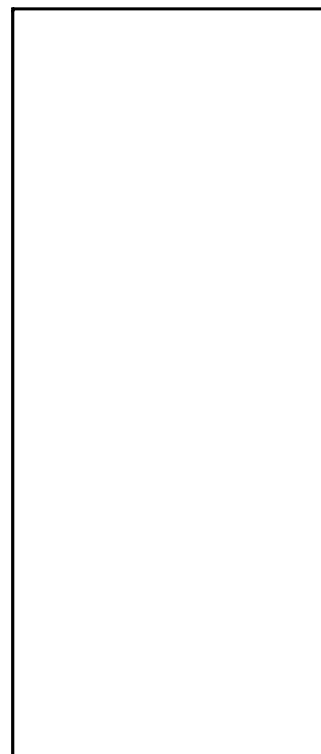

BACK

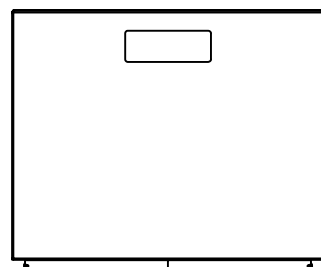

BOTTOM

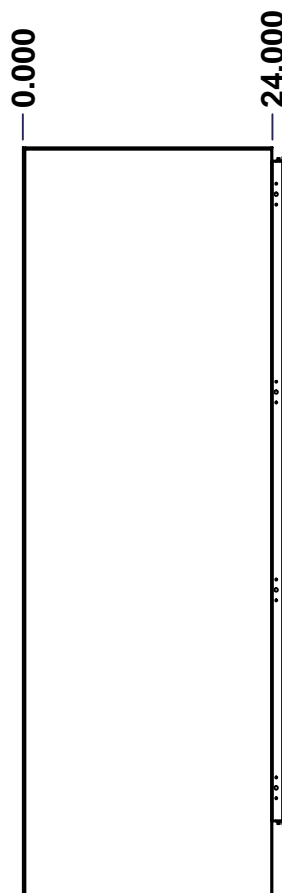

LEFT

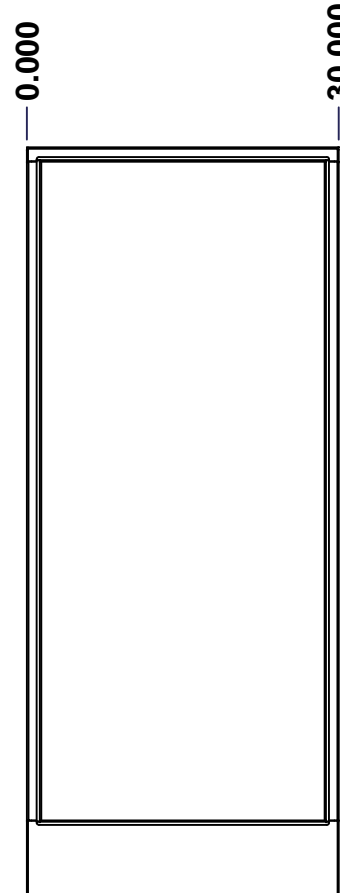

FRONT

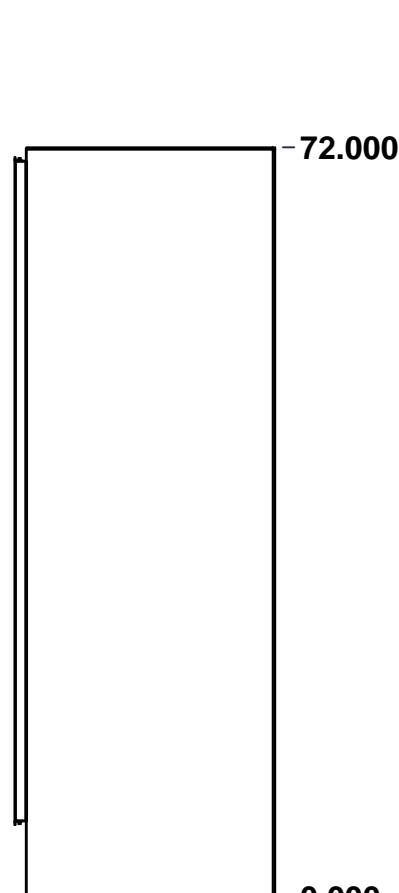

RIGHT

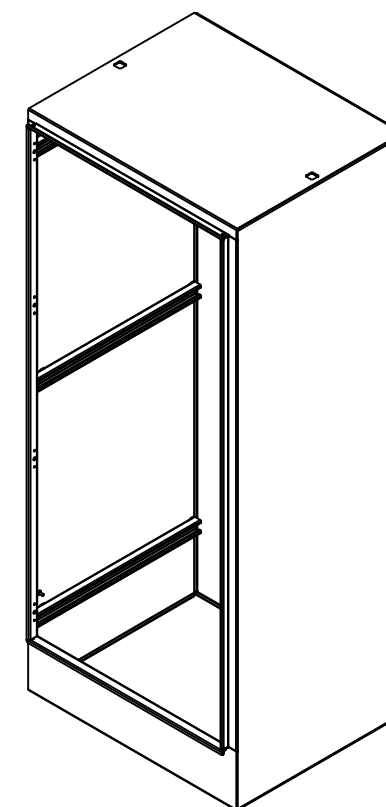

Isometric View

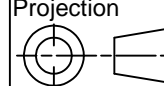

No.	Revisions	Date	By/Par

 Tél: (450) 979-4373 Fax: (450) 979-4626 www.exmweb.com		Flatness Aplatissement Max 3.0mm Projection 
Customer Client	Date	
Drawn By Dessiné Par	BoxCad: BoxCad	Date 28-Jan-21
Material Matière	12 Ga Stainless Steel 304 (2.5mm)	
Color Couleur	Unpainted	Finish Fini Brushed
Description	Detail Rev.	
9412SS 72" x 30" x 24" Body		
Part Number Numéro Pièce	Rev. 0	1 2
9412SS723024B		

SEE BILL OF MATERIAL ON LAST PAGE

This drawing is confidential and must not be reproduced or used without the consent of EXM

Ce dessin est confidentiel et ne doit pas être reproduit ou utilisé sans le consentement de EXM

STANDARD FEATURES ARE NOT LISTED IN THIS HOLE TABLE

HOLE TABLE - TOP VIEW (CUSTOM FEATURE ONLY)

CUT-OUT	XDIM	YDIM	DESCRIPTION
1	14.895	19.895	Struts CR400 21.500" (Inside)
2	14.895	19.895	STUDS M6 x 10mm (Inside)
3	7.145	19.895	STUDS M6 x 10mm (Inside)
4	22.645	19.895	STUDS M6 x 10mm (Inside)

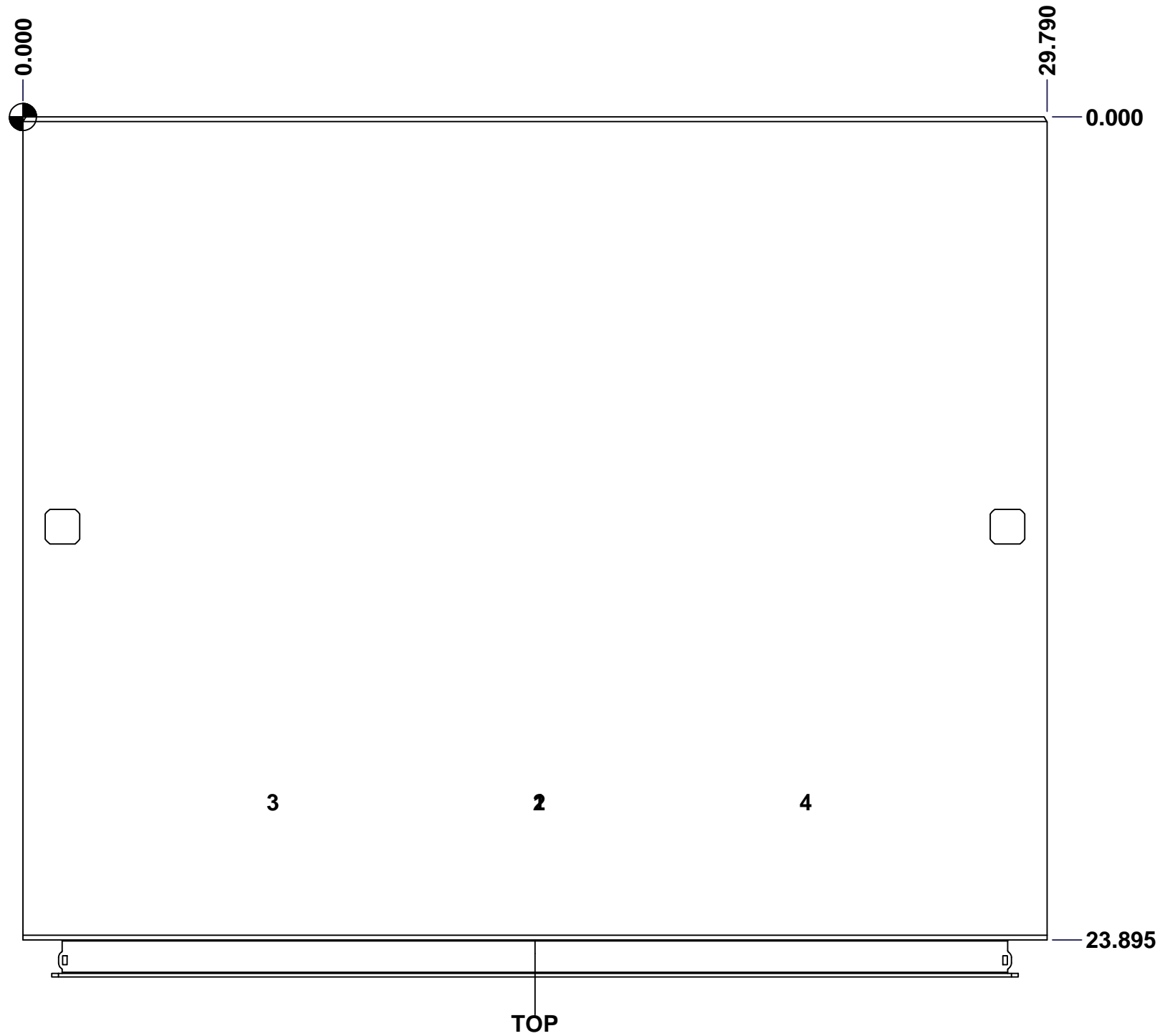

	Description	Status
	9412SS 72" x 30" x 24" Body	Released
	Part Number Numéro Pièce	Rev.
	9412SS723024B	0
		2 / 7

This drawing is confidential and must not be reproduced or used without the consent of EXM

Ce dessin est confidentiel et ne doit pas être reproduit ou utilisé sans le consentement de EXM

STANDARD FEATURES ARE NOT LISTED IN THIS HOLE TABLE

HOLE TABLE - RIGHT VIEW (CUSTOM FEATURE ONLY)

CUT-OUT	XDIM	YDIM	DESCRIPTION
1	3.145	67.020	STUDS M6 x 10mm (Inside)
2	20.645	67.020	STUDS M6 x 10mm (Inside)
3	11.895	67.020	STUDS M6 x 10mm (Inside)
4	3.145	8.770	STUDS M6 x 10mm (Inside)
5	20.645	8.770	STUDS M6 x 10mm (Inside)
6	11.895	8.770	STUDS M6 x 10mm (Inside)
7	3.145	37.895	STUDS M6 x 10mm (Inside)
8	20.645	37.895	STUDS M6 x 10mm (Inside)
9	11.895	37.895	STUDS M6 x 10mm (Inside)

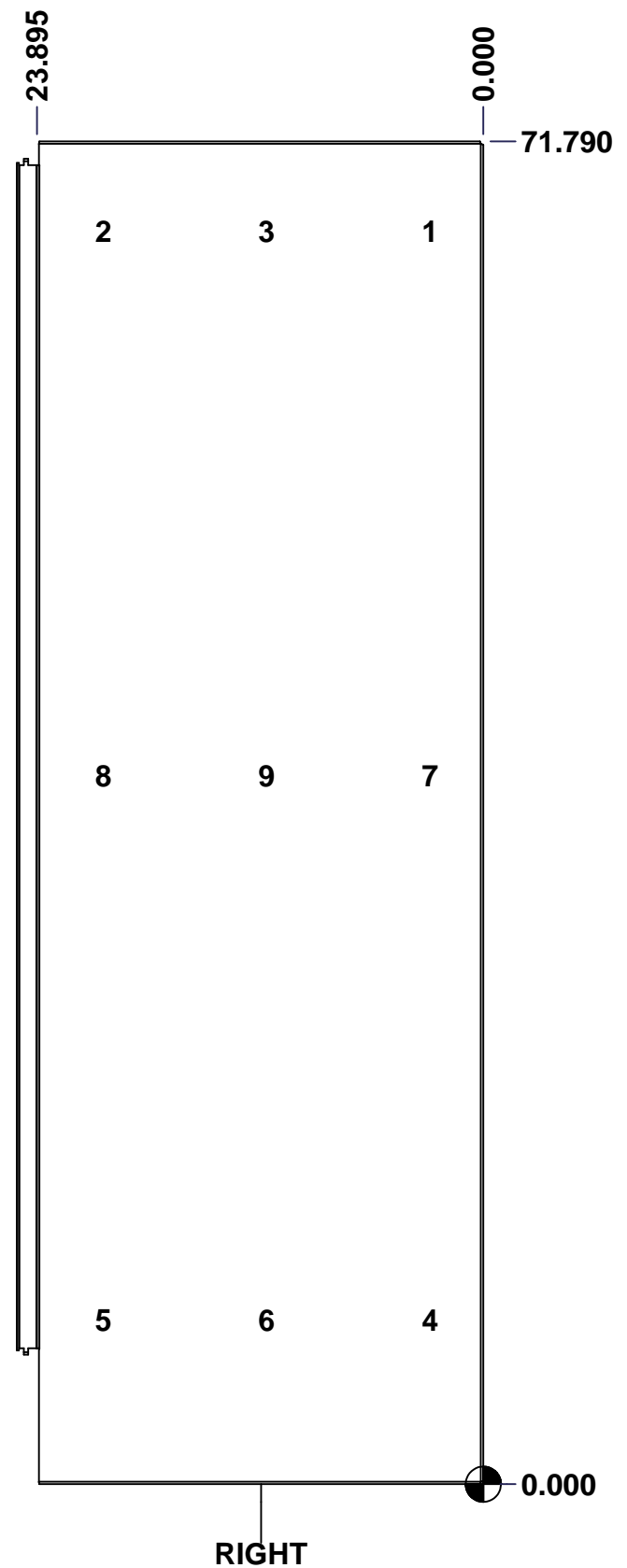

	Description		Status	
	9412SS 72" x 30" x 24" Body		Released	
Part Number Numéro Pièce		Rev.	3	
9412SS723024B		0	7	

This drawing is confidential and must not be reproduced or used without the consent of EXM

Ce dessin est confidentiel et ne doit pas être reproduit ou utilisé sans le consentement de EXM

STANDARD FEATURES ARE NOT LISTED IN THIS HOLE TABLE			
HOLE TABLE - BOTTOM VIEW (CUSTOM FEATURE ONLY)			
CUT-OUT	XDIM	YDIM	DESCRIPTION
1	10.270	3.395	GP STUD M6 x 16mm (Inside)
2	19.520	3.395	GP STUD M6 x 16mm (Inside)

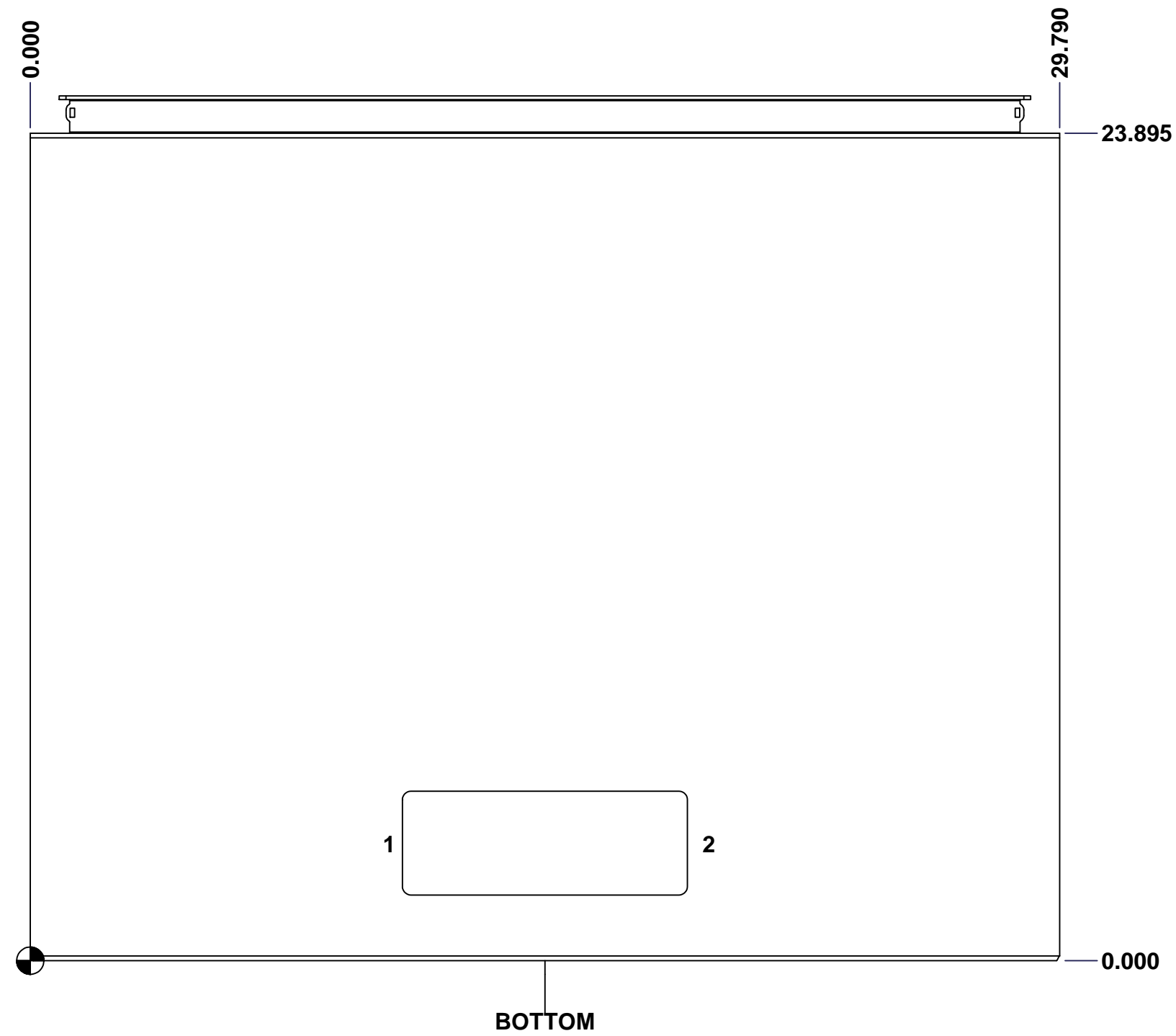

	Description	Status
	9412SS 72" x 30" x 24" Body	Released
	Part Number Numéro Pièce	Rev.
	9412SS723024B	0
		4
		7

This drawing is confidential and must not be reproduced or used without the consent of EXM

Ce dessin est confidentiel et ne doit pas être reproduit ou utilisé sans le consentement de EXM

STANDARD FEATURES ARE NOT LISTED IN THIS HOLE TABLE

HOLE TABLE - LEFT VIEW (CUSTOM FEATURE ONLY)

CUT-OUT	XDIM	YDIM	DESCRIPTION
1	22.395	11.270	GND STUD M6 x 16mm (Inside)
2	3.145	67.020	STUDS M6 x 10mm (Inside)
3	20.645	67.020	STUDS M6 x 10mm (Inside)
4	11.895	67.020	STUDS M6 x 10mm (Inside)
5	3.145	8.770	STUDS M6 x 10mm (Inside)
6	20.645	8.770	STUDS M6 x 10mm (Inside)
7	11.895	8.770	STUDS M6 x 10mm (Inside)
8	3.145	37.895	STUDS M6 x 10mm (Inside)
9	20.645	37.895	STUDS M6 x 10mm (Inside)
10	11.895	37.895	STUDS M6 x 10mm (Inside)

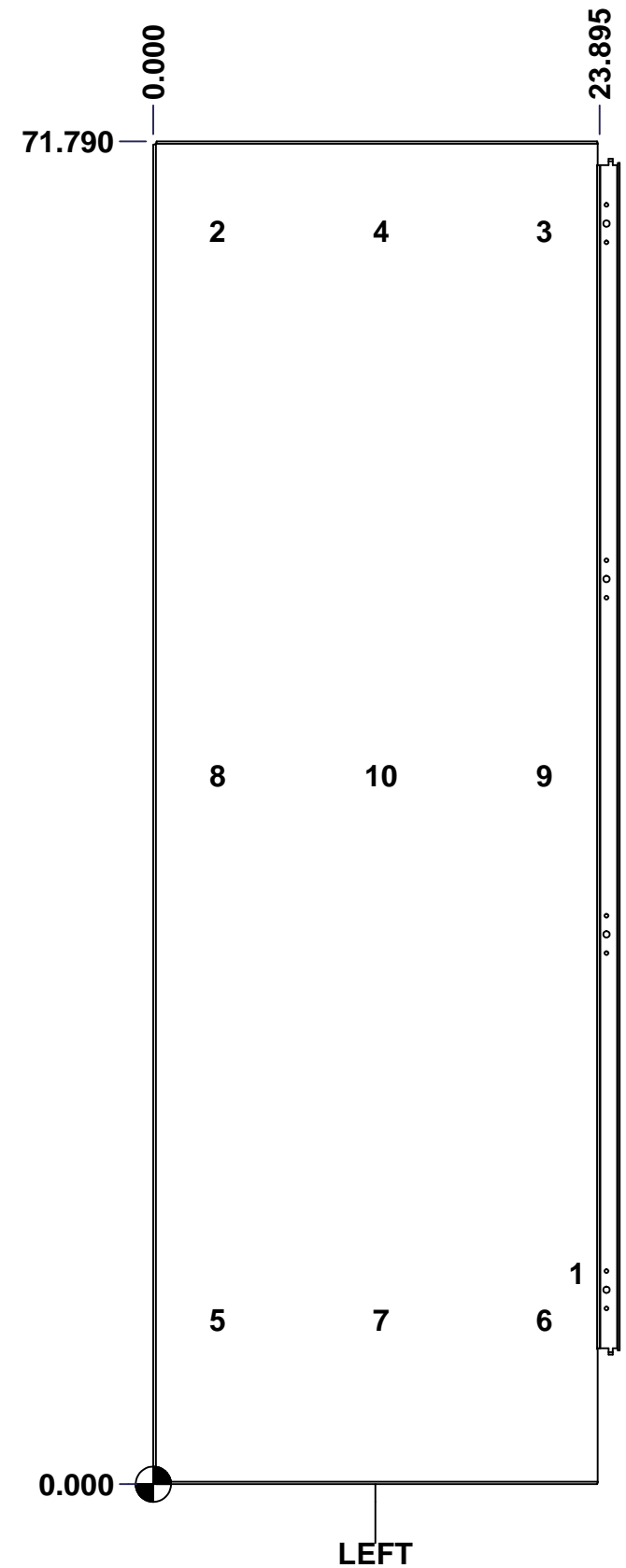

	Description	Status
	9412SS 72" x 30" x 24" Body	Released
	Part Number Numéro Pièce	Rev.
	9412SS723024B	0
		5
		7

This drawing is confidential and must not be reproduced or used without the consent of EXM

Ce dessin est confidentiel et ne doit pas être reproduit ou utilisé sans le consentement de EXM

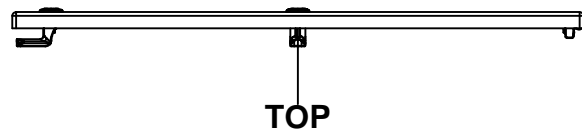

TOP

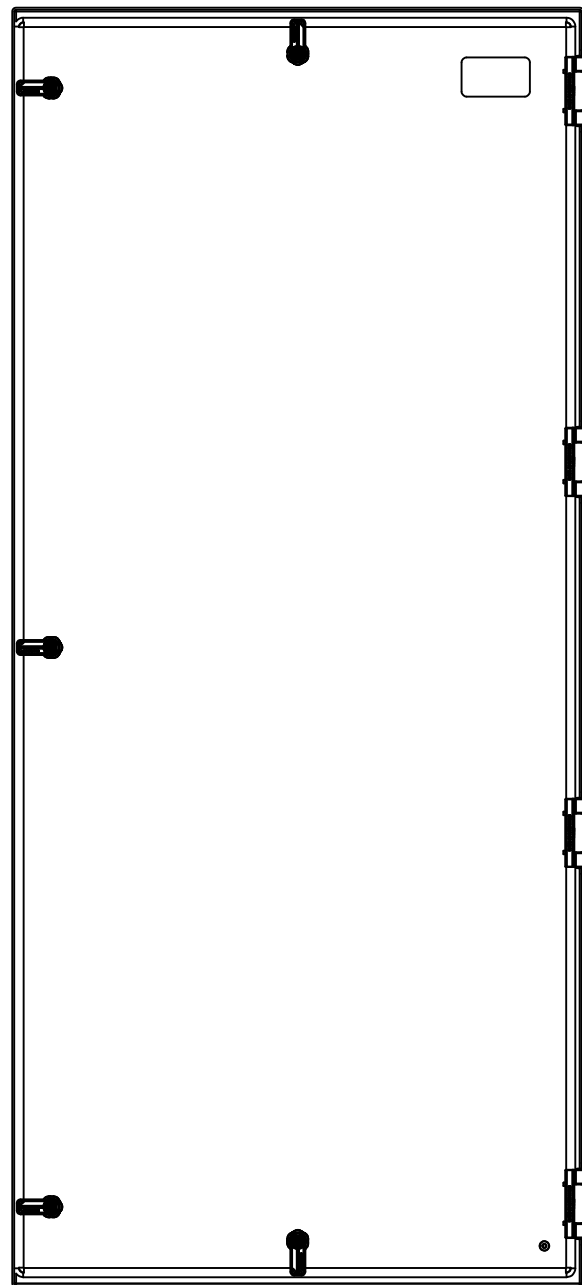

BACK



BOTTOM

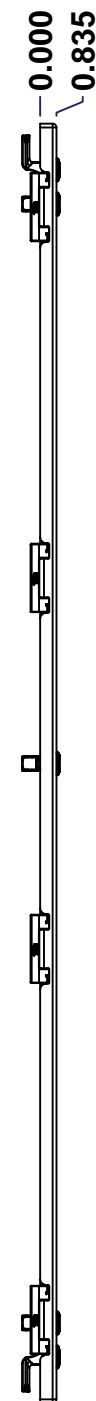

LEFT

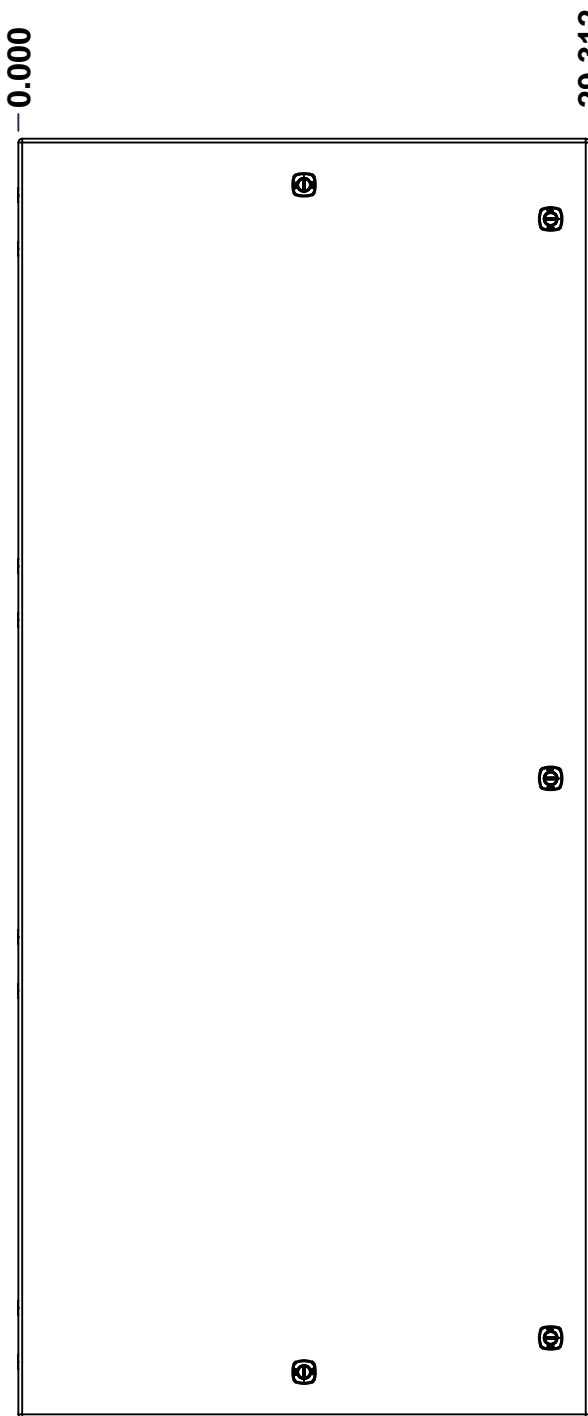

FRONT

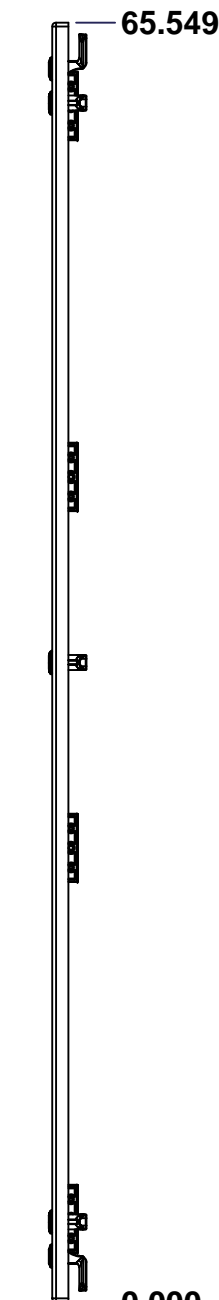

RIGHT

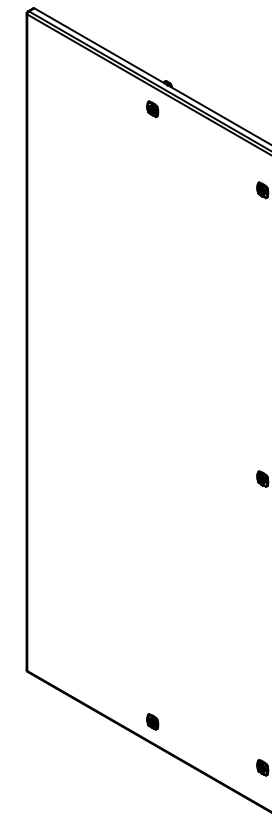

Isometric View

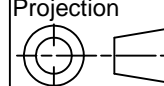

No.	Revisions	Date	By/Par

 Tél: (450) 979-4373 Fax: (450) 979-4626 www.exmweb.com		Flatness Aplatissement Max 3.0mm Projection 
Customer Client	Date	Date
Drawn By Dessiné Par	BoxCad: BoxCad	Date 28-Jan-21
Material Matière	12 Ga Stainless Steel 304 (2.5mm)	
Color Couleur	Unpainted	Finish Fini Brushed
Description	Detail Rev.	
9412SS 72" x 30" Cover		
Part Number Numéro Pièce	Rev.	1 3
9412SS723024C	0	

SEE BILL OF MATERIAL ON LAST PAGE

This drawing is confidential and must not be reproduced or used without the consent of EXM

Ce dessin est confidentiel et ne doit pas être reproduit ou utilisé sans le consentement de EXM

STANDARD FEATURES ARE NOT LISTED IN THIS HOLE TABLE

HOLE TABLE - FRONT VIEW (CUSTOM FEATURE ONLY)

CUT-OUT	XDIM	YDIM	DESCRIPTION
1	14.656	63.180	LOCK 889 SCQ4-SLSS6 @ 90.0°
2	2.000	2.118	GND STUD M6 x 16mm (Inside)
3	27.312	61.430	LOCK 889 SCQ4-SLSS6 @ 0.0°
4	27.312	32.774	LOCK 889 SCQ4-SLSS6 @ 0.0°
5	27.312	4.118	LOCK 889 SCQ4-SLSS6 @ 0.0°
6	14.656	2.368	LOCK 889 SCQ4-SLSS6 @ 270.0°

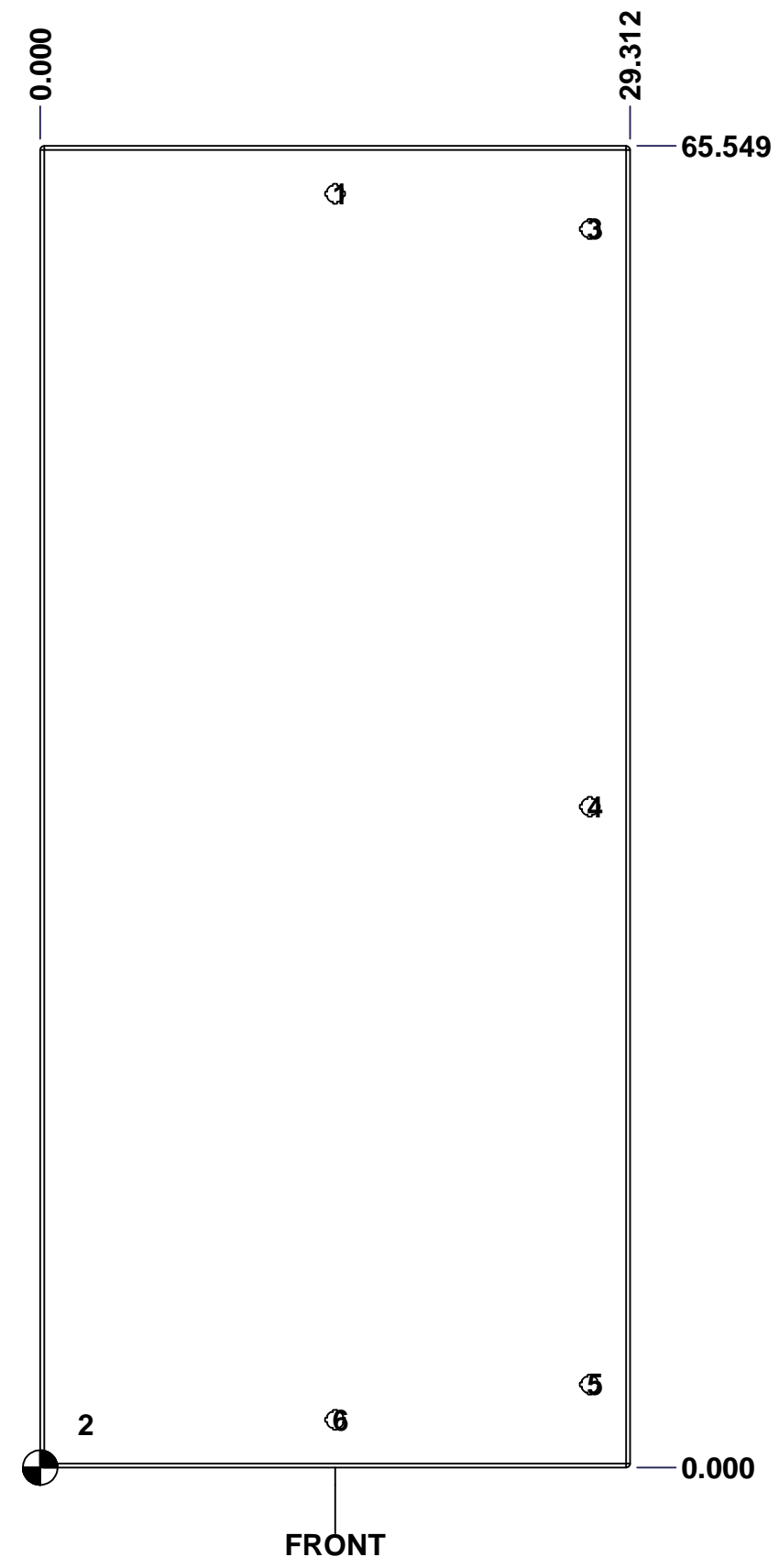

	Description	Status
	9412SS 72" x 30" Cover	(NULL)
	Part Number Numéro Pièce	Rev.
	9412SS723024C	0
		2
		3

This drawing is confidential and must not be reproduced or used without the consent of EXM

Ce dessin est confidentiel et ne doit pas être reproduit ou utilisé sans le consentement de EXM

No.	Revisions	Date	By/Par

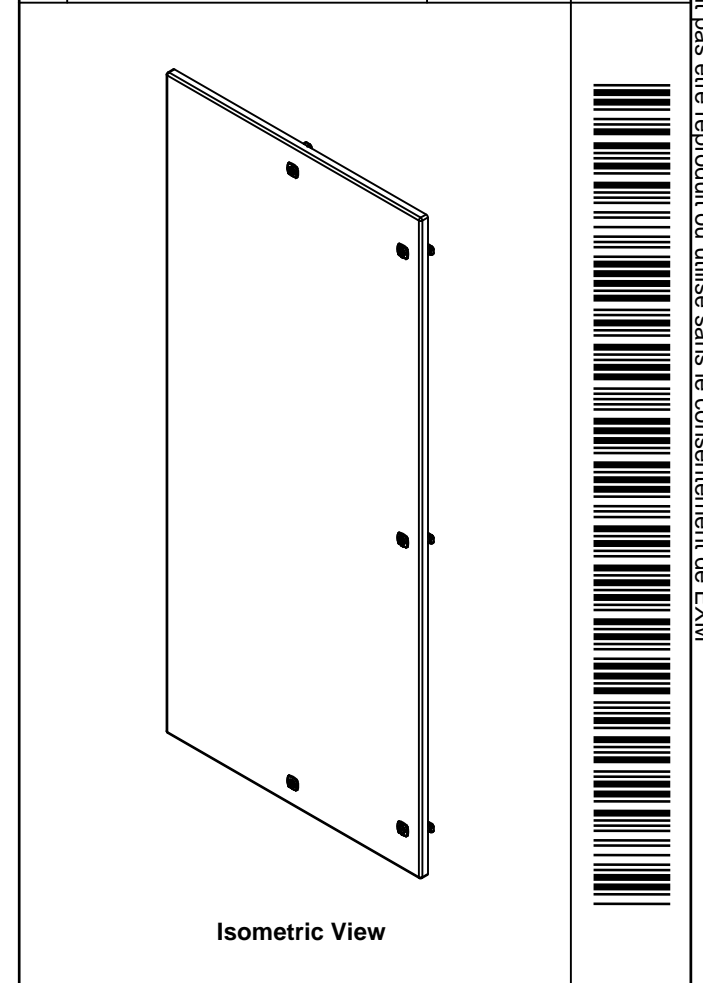

Tél: (450) 979-4373 Fax: (450) 979-4626 www.exmweb.com		Flatness Aplatissement	
		Max 3.0mm Projection	
Customer Client		Date	
Drawn By Dessiné Par		Date	
BoxCad: BoxCad		28-Jan-21	
Material Matière			
12 Ga Stainless Steel 304 (2.5mm)			
Color Couleur		Finish Fini	
Unpainted		Brushed	
Description			Detail Rev.
9412SS 72" x 30" Cover			
Part Number Numéro Pièce		Rev.	3
9412SS723024C		0	3

Qty	Part Name	Rev	Description
1	9412SS723024G	0	9412SS 72" x 30" Cover Gasket
1	STK-Q-16085	0	Ground Stud M6 x 16mm Stainless Steel
1	STK-S-00100	0	3.5" x 2" Silver Milar Flexcon Sticker
1	9412SS723024C-P	0	9412SS 72" x 30" Cover Part
4	STK-K-09870	7	Cabinet Hinge with Captive Pins
5	889 SCQ4-SLSS6	0	9412 SS 1/4 Turn Lock
Parts List			

All knockouts are actual size / Les disques défonçables sont grandeur réel
 All dimensions are before paint / Toutes les dimensions sont avant peinture

This drawing is confidential and must not be reproduced or used without the consent of EXM

Ce dessin est confidentiel et ne doit pas être reproduit ou utilisé sans le consentement de EXM

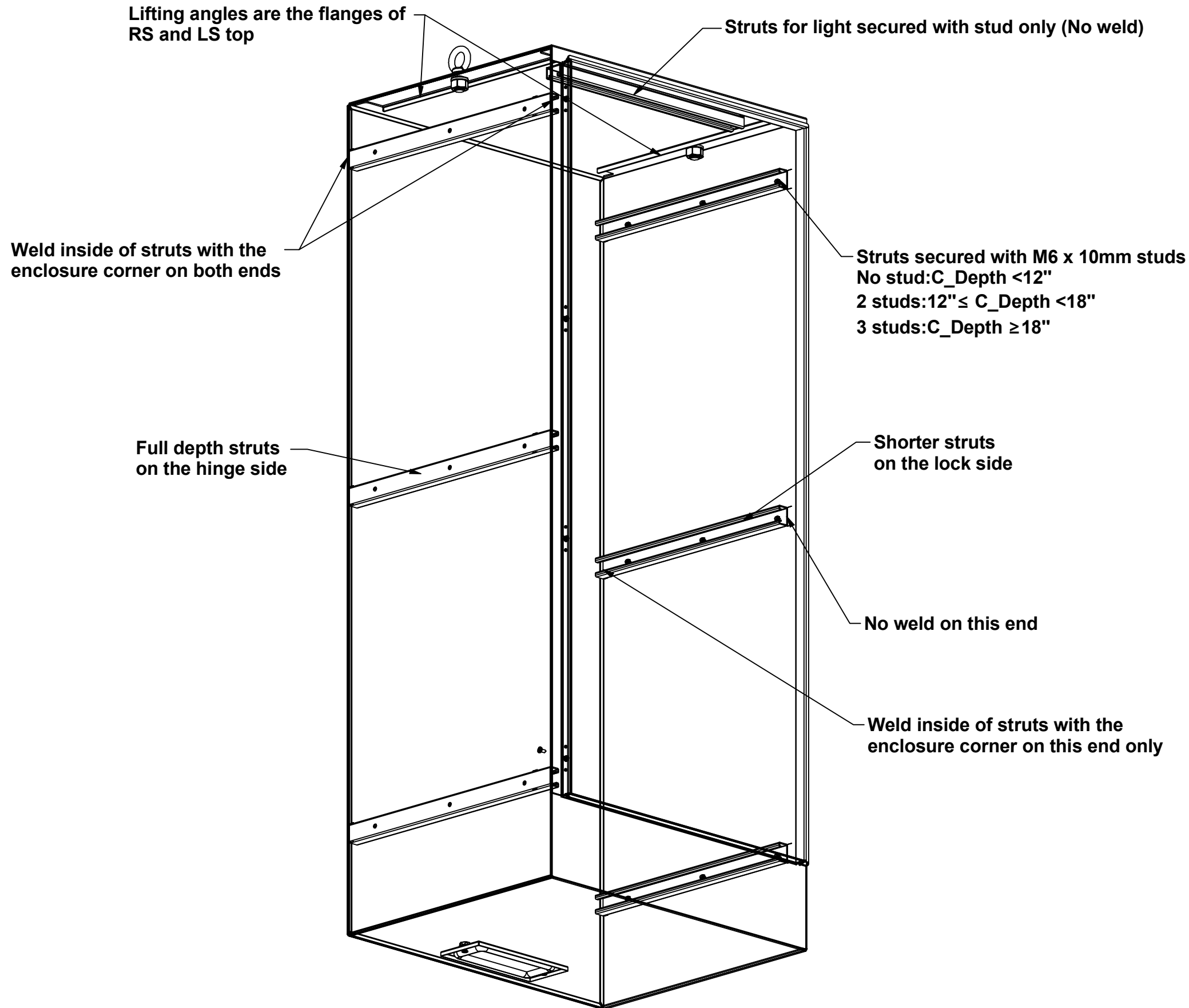

No.	Revisions	Date	By/Par

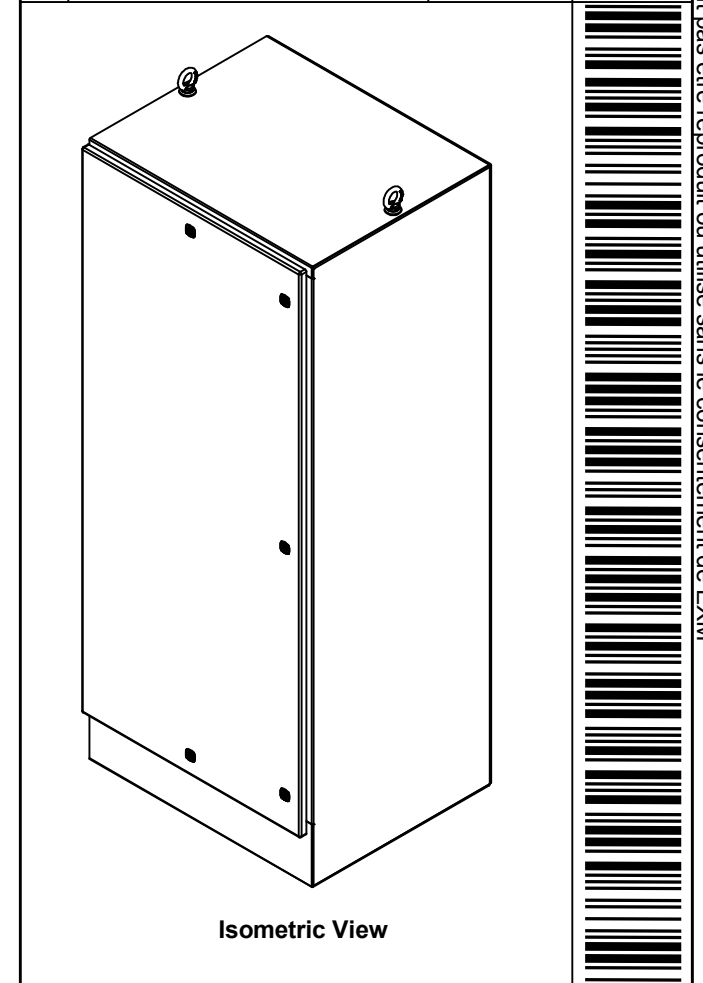

Tél: (450) 979-4373 Fax: (450) 979-4626 www.exmweb.com		Flatness Aplatissement
		Max 3.0mm
Customer Client		Date
Drawn By Dessiné Par PatrickD		Date 3/9/2020
Material Matière N/A		
Color Couleur N/A	Finish Fini N/A	
Description 9412SS Welding Detail		Detail Rev.
Part Number Numéro Pièce 9412SS_WELDING_DETAIL	Rev. 1	1 1