

This drawing is confidential and must not be reproduced or used without the consent of EXM

Ce dessin est confidentiel et ne doit pas être reproduit ou utilisé sans le consentement de EXM

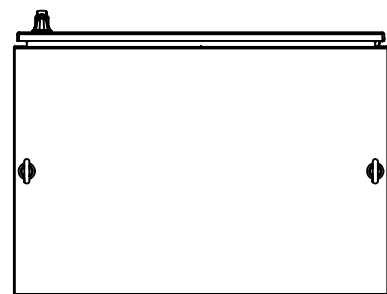

TOP

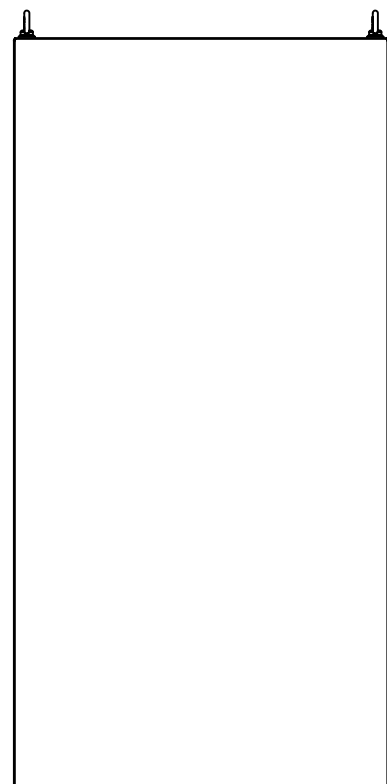

BACK

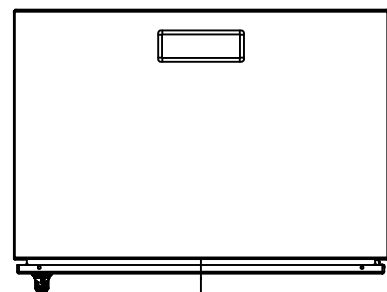

BOTTOM

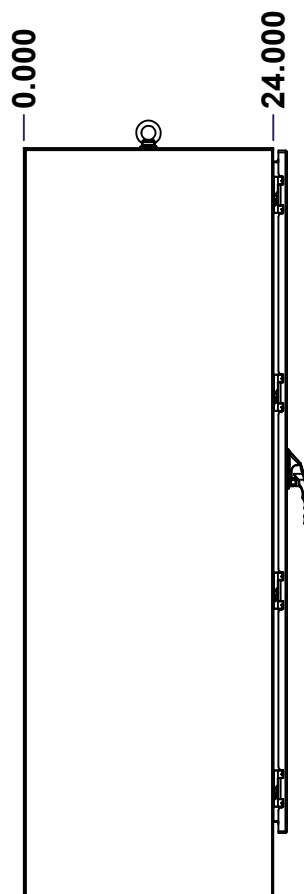

LEFT

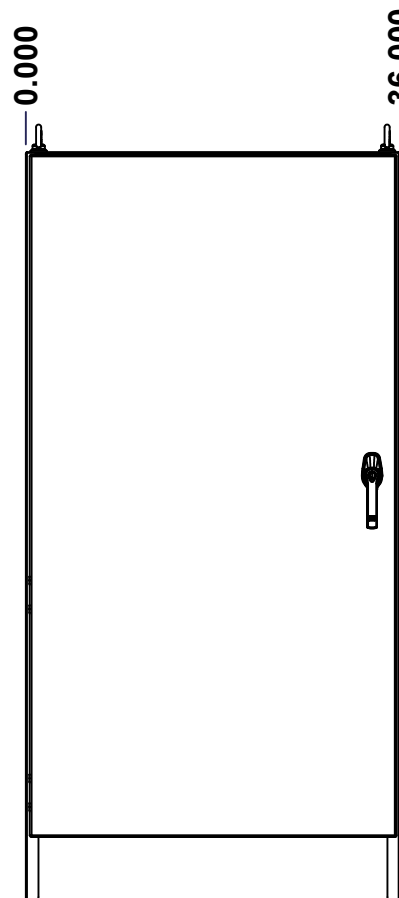

FRONT

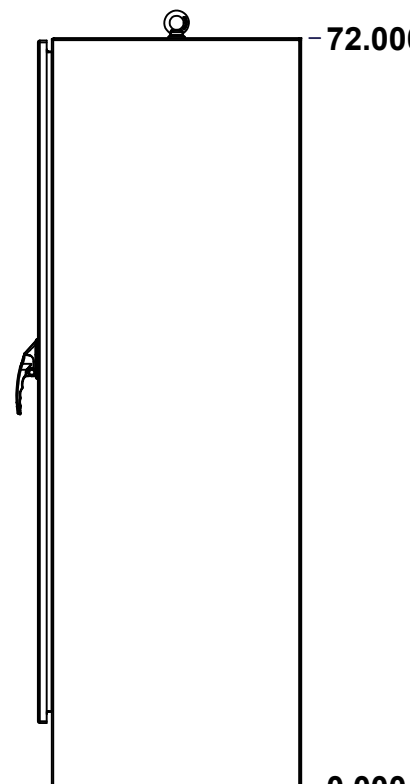

RIGHT

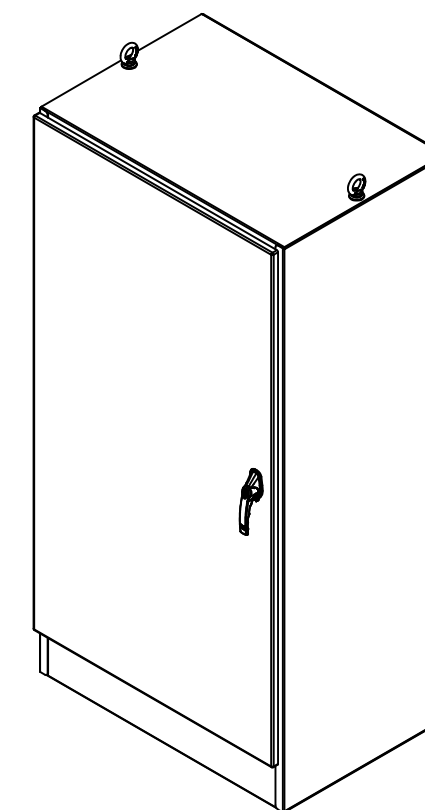

Isometric View

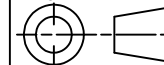

| No. | Revisions | Date | By/Par |
|-----|-----------|------|--------|
| | | | |
| | | | |
| | | | |
| | | | |
| | | | |

| | | |
|--|---|---|
|  Tél: (450) 979-4373 Fax: (450) 979-4626 www.exmweb.com | | Flatness Aplatissement Max 3.0mm Projection  |
| Customer Client | Date | |
| Drawn By Dessiné Par | BoxCad: BoxCad | Date 2/12/2013 |
| Material Matière | 12 Ga Cold Rolled A1008 CS Type B (2.5mm) | |
| Color Couleur | Asa-61 Grey | Finish Fini Smooth |
| Description | 9500 72" x 36" x 24" Assembly | |
| Part Number Numéro Pièce | Rev. 0 | 1 2 |

SEE BILL OF MATERIAL ON LAST PAGE

9500723624

This drawing is confidential and must not be reproduced or used without the consent of EXM

Ce dessin est confidentiel et ne doit pas être reproduit ou utilisé sans le consentement de EXM

| NOTE | |
|------|--|
| ITEM | DESCRIPTION |
| 1 | NEMA 12/13 Enclosure |
| 2 | C/W Standard ground studs on box and cover |
| 3 | C/W Standard door stiffener |
| 4 | W/O Inner panel |
| 5 | C/W Standard inner panel mounting struts |
| 6 | C/W Eyebolts |
| 7 | C/W Struts installed (Included) |

| No. | Revisions | Date | By/Par |
|-----|-----------|------|--------|
| | | | |
| | | | |
| | | | |
| | | | |
| | | | |
| | | | |

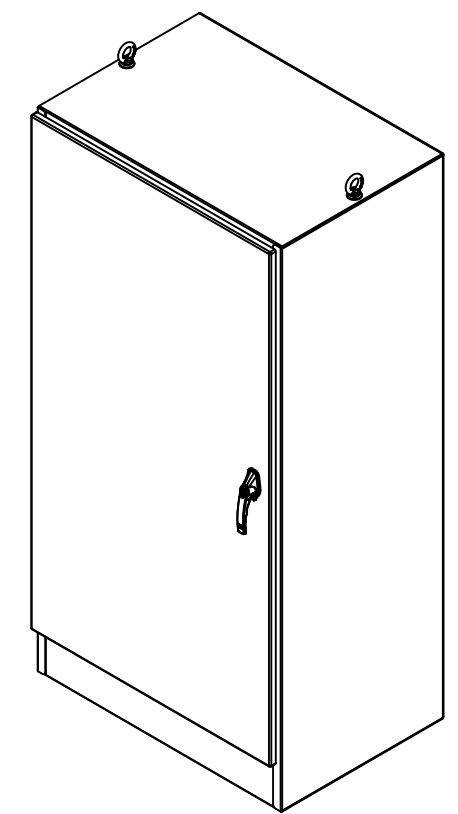

Isometric View



| PACKING | | |
|-----------------------|-----|--|
| ITEM | QTY | DESCRIPTION |
| Cardboard sleeve | 2 | Top and Bottom |
| Cardboard strip | 2 | Between back of enclosure and inner panel |
| Plastic bag | 1 | To protect cover surface and inside gasket |
| Cardboard corner | 4 | To reinforced for the plastic strap tightening |
| Plastic strap - Black | 2 | To Squeeze 2 cardboard sleeve together |
| Packaging label | 3 | White label with PN |
| Plastic strap- Green | 2 | To secure the enclosure to the wood pallet |
| Wood Pallet | 1 | 2" deeper and 3" larger than enclosure size |

| Qty | Part Number | Rev | Description |
|------------|----------------|-----|---|
| 1 | 9500723624GP | 0 | 9500 Gland Plate |
| 1 | 880EB14 | 2 | Eye Bolt M14 (Pack of 2) |
| 1 | 9500723624C | 0 | 9500 72" x 36" Cover |
| 1 | 9500723624B | 0 | 9500 72" x 36" x 24" Body |
| 4 | STK-Q-04050-10 | 8 | M6 x 10mm Hexagon Socket Head Machine Screw with Nyseal |
| Parts List | | | |

| | | |
|--|--|--|
| | Tél: (450) 979-4373 Fax: (450) 979-4626 www.exmweb.com | Flatness Aplatissement Max 3.0mm Projection |
| | Customer Client | Date |
| Drawn By Dessiné Par | BoxCad: BoxCad | Date 2/12/2013 |
| Material Matière | 12 Ga Cold Rolled A1008 CS Type B (2.5mm) | |
| Color Couleur | Asa-61 Grey | Finish Fini Smooth |
| Description 9500 72" x 36" x 24" Assembly | Detail Rev. | |
| Part Number Numéro Pièce | 9500723624 | Rev. 0 |

This drawing is confidential and must not be reproduced or used without the consent of EXM

Ce dessin est confidentiel et ne doit pas être reproduit ou utilisé sans le consentement de EXM

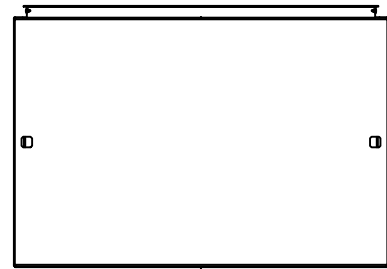

TOP

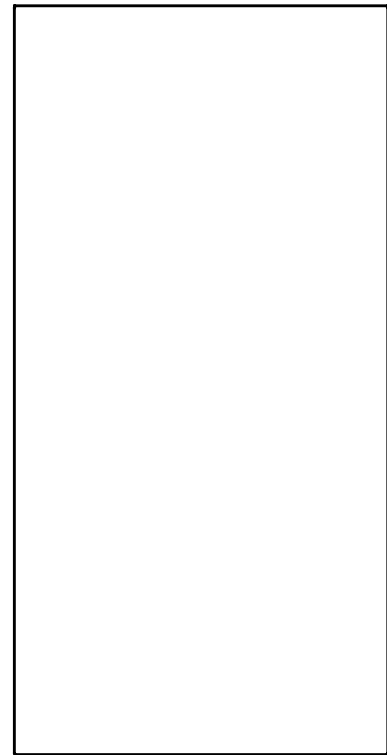

BACK

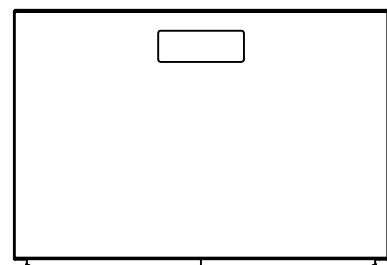

BOTTOM

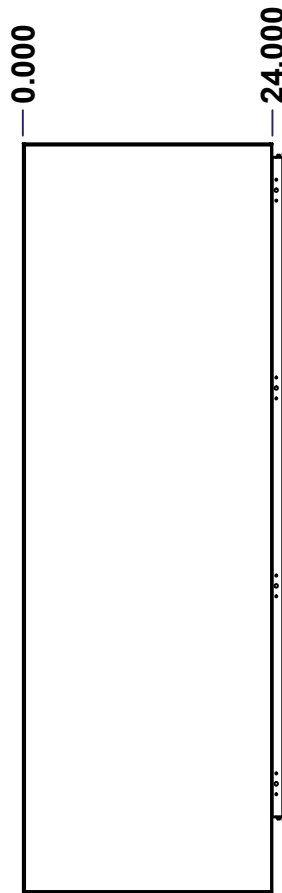

LEFT

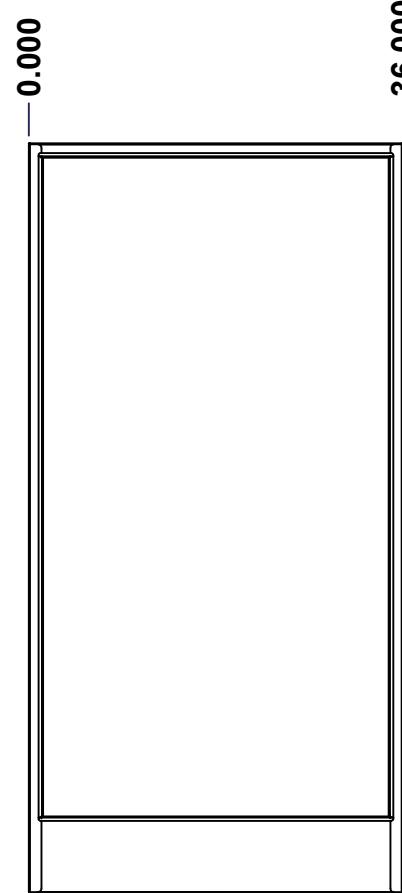

FRONT

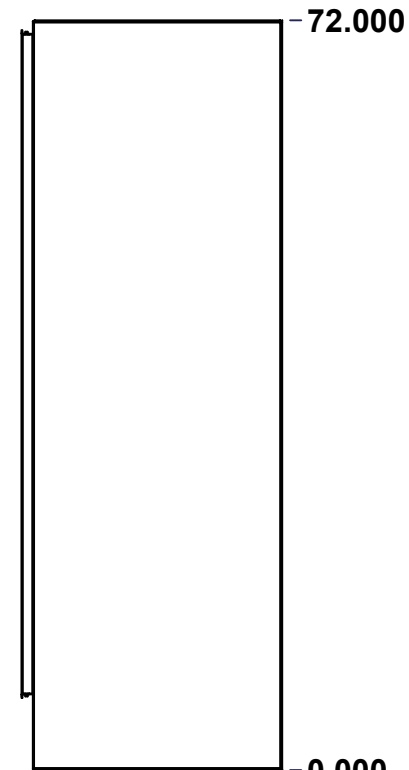

RIGHT

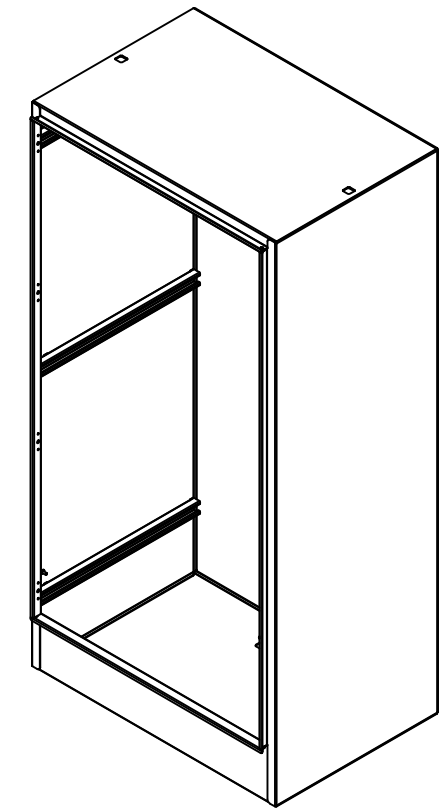

Isometric View

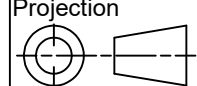

| No. | Revisions | Date | By/Par |
|-----|-----------|------|--------|
| | | | |
| | | | |
| | | | |
| | | | |
| | | | |

| | | |
|--|---|---|
|  Tél: (450) 979-4373 Fax: (450) 979-4626 www.exmweb.com | | Flatness Aplatissement Max 3.0mm Projection  |
| Customer Client | Date | |
| Drawn By Dessiné Par | BoxCad: BoxCad | Date 2/12/2013 |
| Material Matière | 12 Ga Cold Rolled A1008 CS Type B (2.5mm) | |
| Color Couleur | Asa-61 Grey | Finish Fini Smooth |
| Description 9500 72" x 36" x 24" Body | | Detail Rev. |
| Part Number Numéro Pièce | 9500723624B | Rev. 1 0 |

SEE BILL OF MATERIAL ON LAST PAGE

This drawing is confidential and must not be reproduced or used without the consent of EXM

Ce dessin est confidentiel et ne doit pas être reproduit ou utilisé sans le consentement de EXM

| STANDARD FEATURES ARE NOT LISTED IN THIS HOLE TABLE | | | |
|---|--------|--------|-------------------------------|
| HOLE TABLE - TOP VIEW (CUSTOM FEATURE ONLY) | | | |
| CUT-OUT | XDIM | YDIM | DESCRIPTION |
| 1 | 17.911 | 19.911 | Struts CR400 27.500" (Inside) |
| 2 | 17.911 | 19.911 | STUDS M6 x 10mm (Inside) |
| 3 | 7.161 | 19.911 | STUDS M6 x 10mm (Inside) |
| 4 | 28.661 | 19.911 | STUDS M6 x 10mm (Inside) |

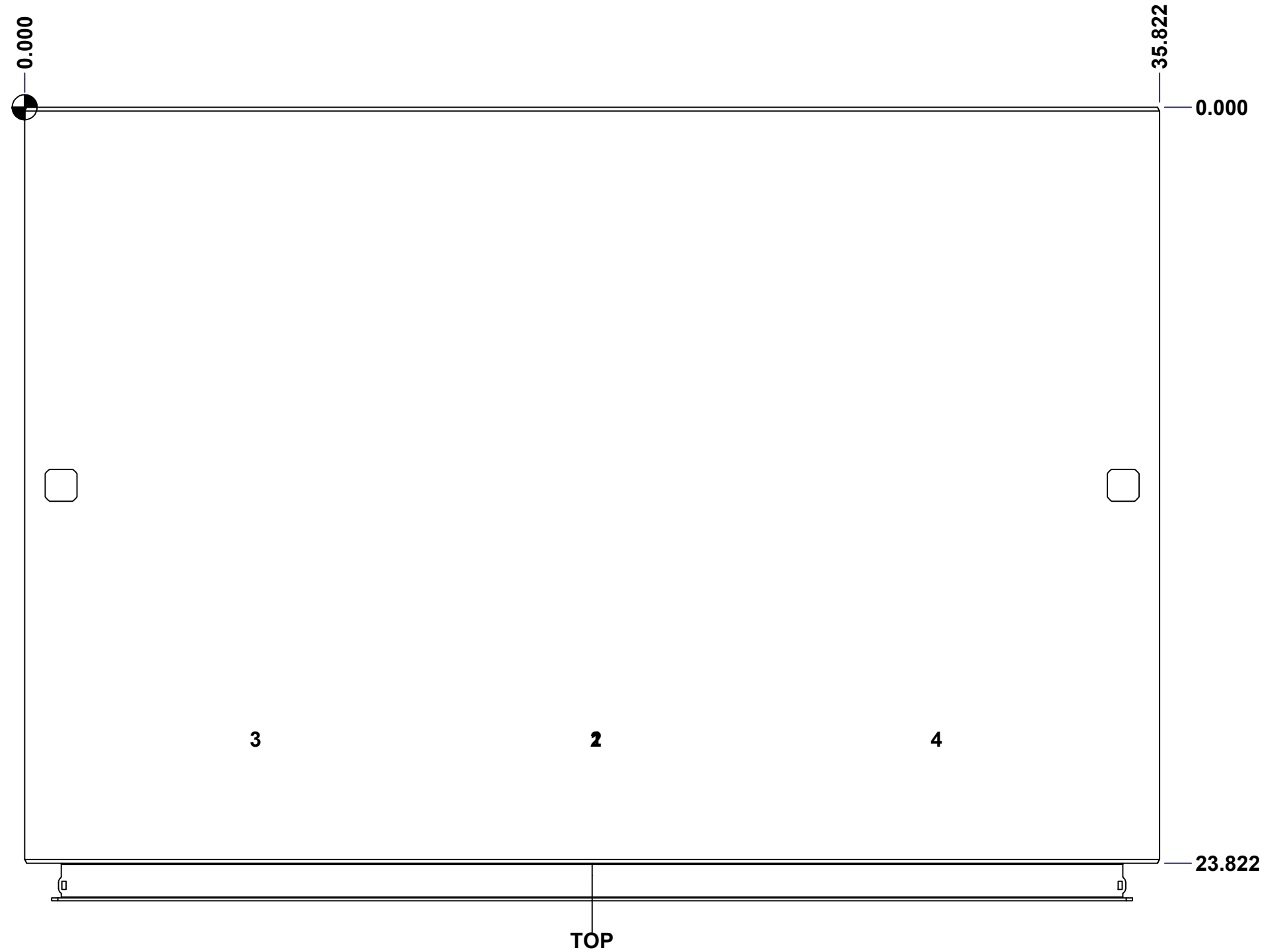

| | | |
|--|-----------------------------|----------|
| | Description | Status |
| | 9500 72" x 36" x 24" Body | Released |
| | Part Number Numéro Pièce | Rev. |
| | 9500723624B | 0 |
| | | 2 / 7 |

This drawing is confidential and must not be reproduced or used without the consent of EXM

Ce dessin est confidentiel et ne doit pas être reproduit ou utilisé sans le consentement de EXM

STANDARD FEATURES ARE NOT LISTED IN THIS HOLE TABLE

HOLE TABLE - RIGHT VIEW (CUSTOM FEATURE ONLY)

| CUT-OUT | XDIM | YDIM | DESCRIPTION |
|---------|--------|--------|--------------------------|
| 1 | 3.161 | 67.036 | STUDS M6 x 10mm (Inside) |
| 2 | 20.661 | 67.036 | STUDS M6 x 10mm (Inside) |
| 3 | 11.911 | 67.036 | STUDS M6 x 10mm (Inside) |
| 4 | 3.161 | 8.786 | STUDS M6 x 10mm (Inside) |
| 5 | 20.661 | 8.786 | STUDS M6 x 10mm (Inside) |
| 6 | 11.911 | 8.786 | STUDS M6 x 10mm (Inside) |
| 7 | 3.161 | 37.911 | STUDS M6 x 10mm (Inside) |
| 8 | 20.661 | 37.911 | STUDS M6 x 10mm (Inside) |
| 9 | 11.911 | 37.911 | STUDS M6 x 10mm (Inside) |

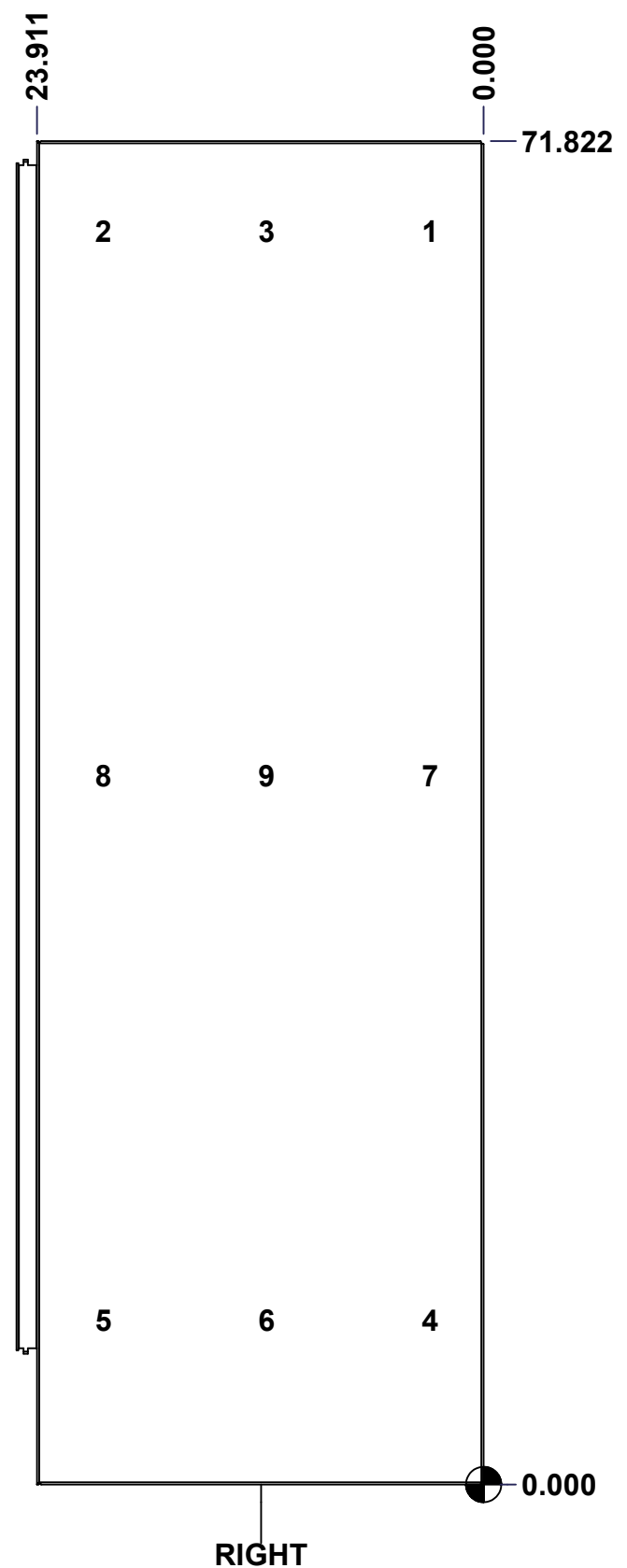

| | | | |
|--|-----------------------------|----------|-------|
| | Description | Status | |
| | 9500 72" x 36" x 24" Body | Released | |
| | Part Number Numéro Pièce | Rev. | |
| | 9500723624B | 0 | 3 / 7 |

This drawing is confidential and must not be reproduced or used without the consent of EXM

Ce dessin est confidentiel et ne doit pas être reproduit ou utilisé sans le consentement de EXM

| STANDARD FEATURES ARE NOT LISTED IN THIS HOLE TABLE | | | |
|---|--------|-------|----------------------------|
| HOLE TABLE - BOTTOM VIEW (CUSTOM FEATURE ONLY) | | | |
| CUT-OUT | XDIM | YDIM | DESCRIPTION |
| 1 | 13.286 | 3.411 | GP STUD M6 x 16mm (Inside) |
| 2 | 22.536 | 3.411 | GP STUD M6 x 16mm (Inside) |

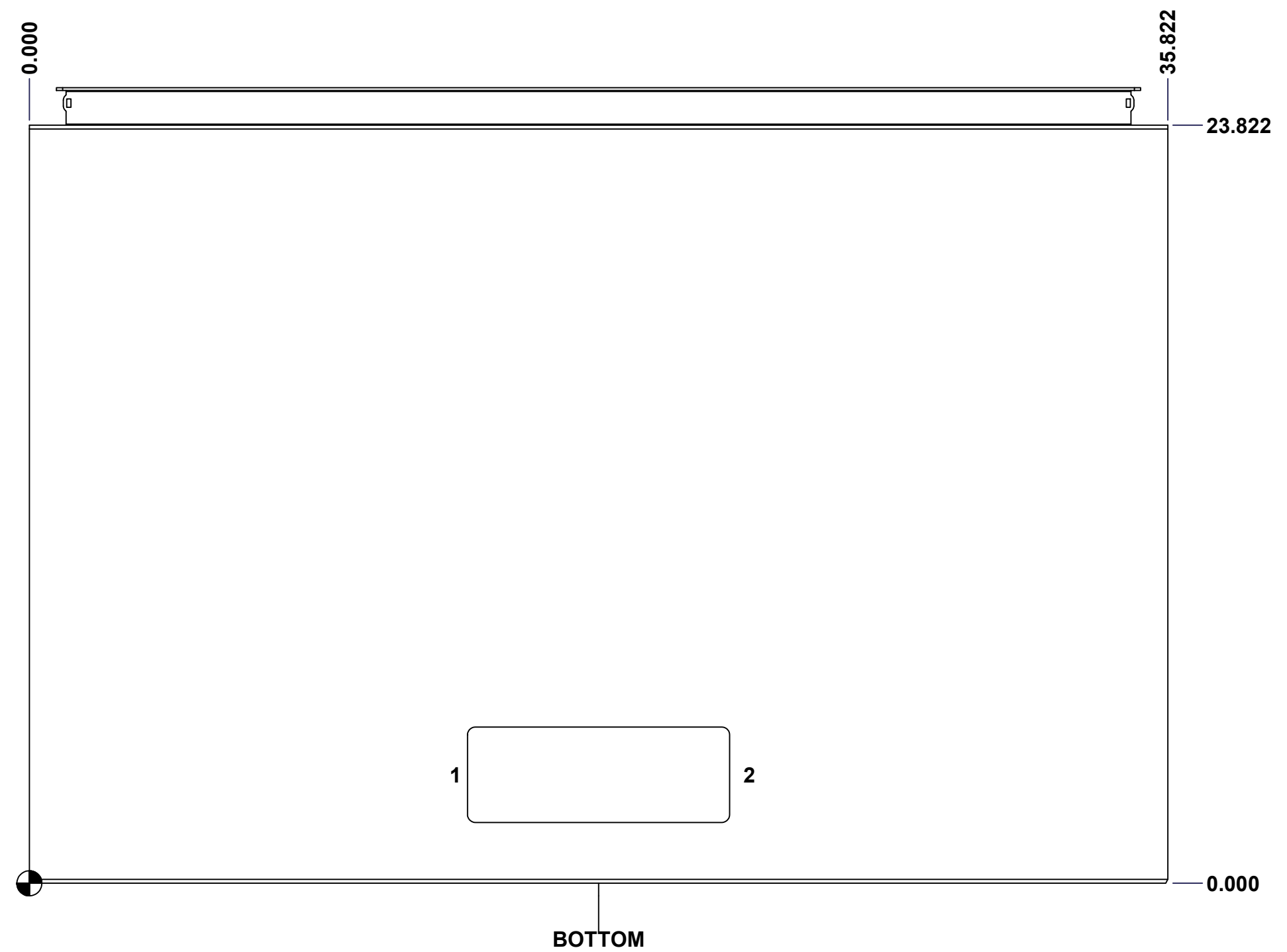

| | | |
|--|-----------------------------|----------|
| | Description | Status |
| | 9500 72" x 36" x 24" Body | Released |
| | Part Number Numéro Pièce | Rev. |
| | 9500723624B | 0 |
| | | 4 / 7 |

This drawing is confidential and must not be reproduced or used without the consent of EXM

Ce dessin est confidentiel et ne doit pas être reproduit ou utilisé sans le consentement de EXM

STANDARD FEATURES ARE NOT LISTED IN THIS HOLE TABLE

HOLE TABLE - LEFT VIEW (CUSTOM FEATURE ONLY)

| CUT-OUT | XDIM | YDIM | DESCRIPTION |
|---------|--------|--------|-----------------------------|
| 1 | 22.411 | 11.286 | GND STUD M6 x 16mm (Inside) |
| 2 | 3.161 | 67.036 | STUDS M6 x 10mm (Inside) |
| 3 | 20.661 | 67.036 | STUDS M6 x 10mm (Inside) |
| 4 | 11.911 | 67.036 | STUDS M6 x 10mm (Inside) |
| 5 | 3.161 | 8.786 | STUDS M6 x 10mm (Inside) |
| 6 | 20.661 | 8.786 | STUDS M6 x 10mm (Inside) |
| 7 | 11.911 | 8.786 | STUDS M6 x 10mm (Inside) |
| 8 | 3.161 | 37.911 | STUDS M6 x 10mm (Inside) |
| 9 | 20.661 | 37.911 | STUDS M6 x 10mm (Inside) |
| 10 | 11.911 | 37.911 | STUDS M6 x 10mm (Inside) |

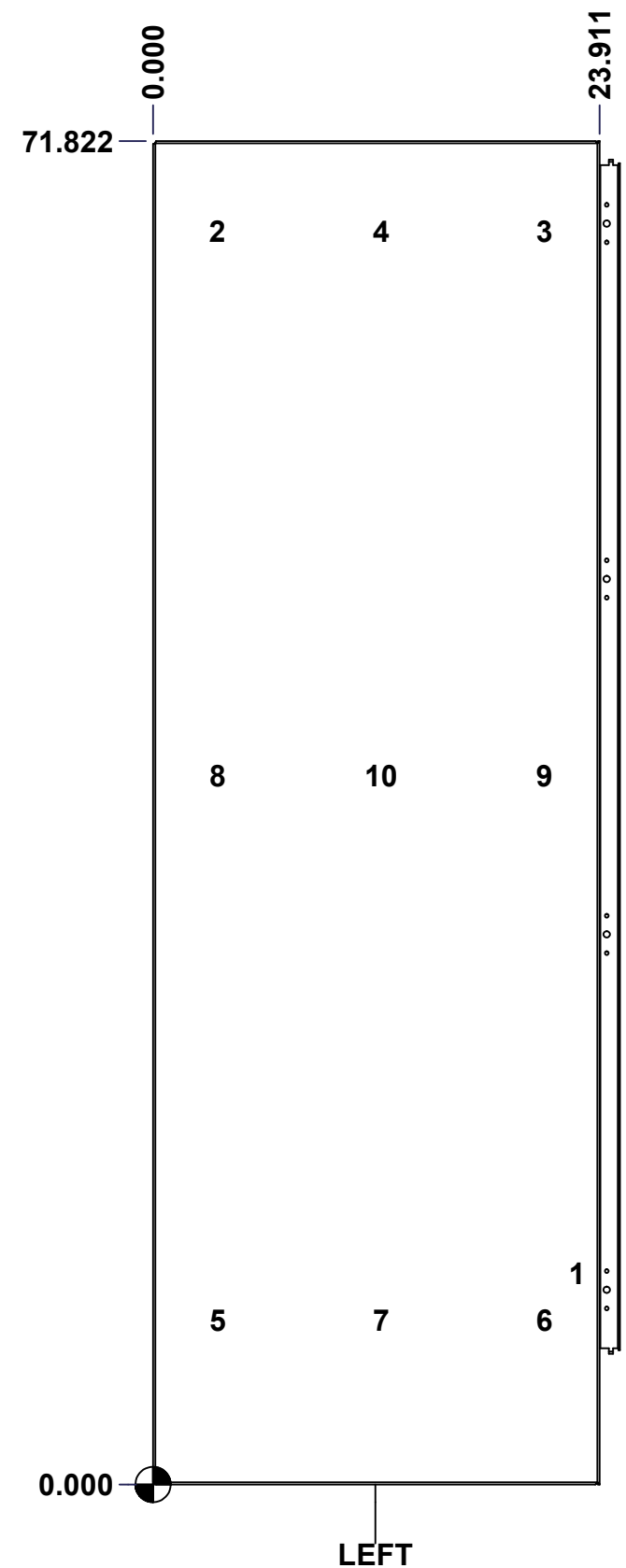

| | | |
|--|-----------------------------|----------|
| | Description | Status |
| | 9500 72" x 36" x 24" Body | Released |
| | Part Number Numéro Pièce | Rev. |
| | 9500723624B | 0 |
| | | 5 |
| | | 7 |

This drawing is confidential and must not be reproduced or used without the consent of EXM

Ce dessin est confidentiel et ne doit pas être reproduit ou utilisé sans le consentement de EXM

| No. | Revisions | Date | By/Par |
|-----|-----------|------|--------|
| | | | |
| | | | |
| | | | |
| | | | |
| | | | |

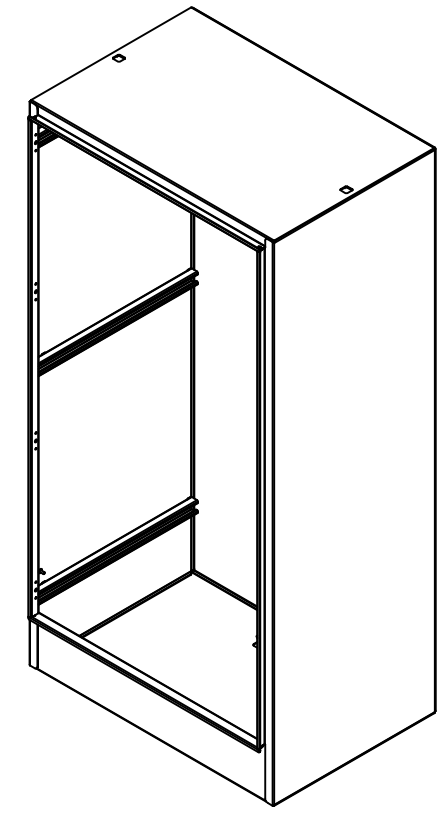

Isometric View

| Qty | Part Number | Rev | Description |
|-----|----------------|-----|--|
| 21 | STK-Q-16030 | 0 | Stud M6 x 10mm |
| 1 | CR400MS_27.5 | 0 | Commercial Roll Mild Steel (27.5in long) |
| 1 | STK-P-02400S | 0 | Powder Paint (Asa-61 Grey / Smooth) |
| 1 | STK-Q-52200-24 | 2 | Sasco Strut S5 (21.500" Long) |
| 5 | STK-Q-52250-24 | 2 | Sasco Strut S5 (23.500" Long) |
| 1 | 9500723624BT-P | 0 | 9500 36" x 24" Bottom Part |
| 1 | 9500723624T-P | 0 | 9500 36" x 24" Top Part |
| 1 | 9500723624RS-P | 0 | 9500 72" x 36" Right Part |
| 1 | 9500723624LS-P | 0 | 9500 72" x 36" Left Part |
| 1 | 9500723624B-P | 0 | 9500 72" x 36" Back Part |
| 21 | STK-Q-07220 | 1 | M6 Nylon Insert Lock Nut |
| 3 | STK-Q-16080 | 0 | Ground Stud M6 x 16mm |
| | | | |
| | | | |
| | | | |
| | | | |
| | | | |
| | | | |
| | | | |
| | | | |
| | | | |
| | | | |
| | | | |

| | | | |
|--|--|-------------------------------|-----------------------------|
| | Tél: (450) 979-4373 Fax: (450) 979-4626 www.exmweb.com | Flatness Aplatissement | Max 3.0mm Projection |
| | | Customer Client | Date |
| | | Drawn By Dessiné Par | Date |
| Material Matière | 12 Ga Cold Rolled A1008 CS Type B (2.5mm) | Color Couleur | Finish Fini |
| Description 9500 72" x 36" x 24" Body | | Detail Rev. | |
| Part Number Numéro Pièce | 9500723624B | Rev. | 2 0 |

Parts List

This drawing is confidential and must not be reproduced or used without the consent of EXM

Ce dessin est confidentiel et ne doit pas être reproduit ou utilisé sans le consentement de EXM



TOP

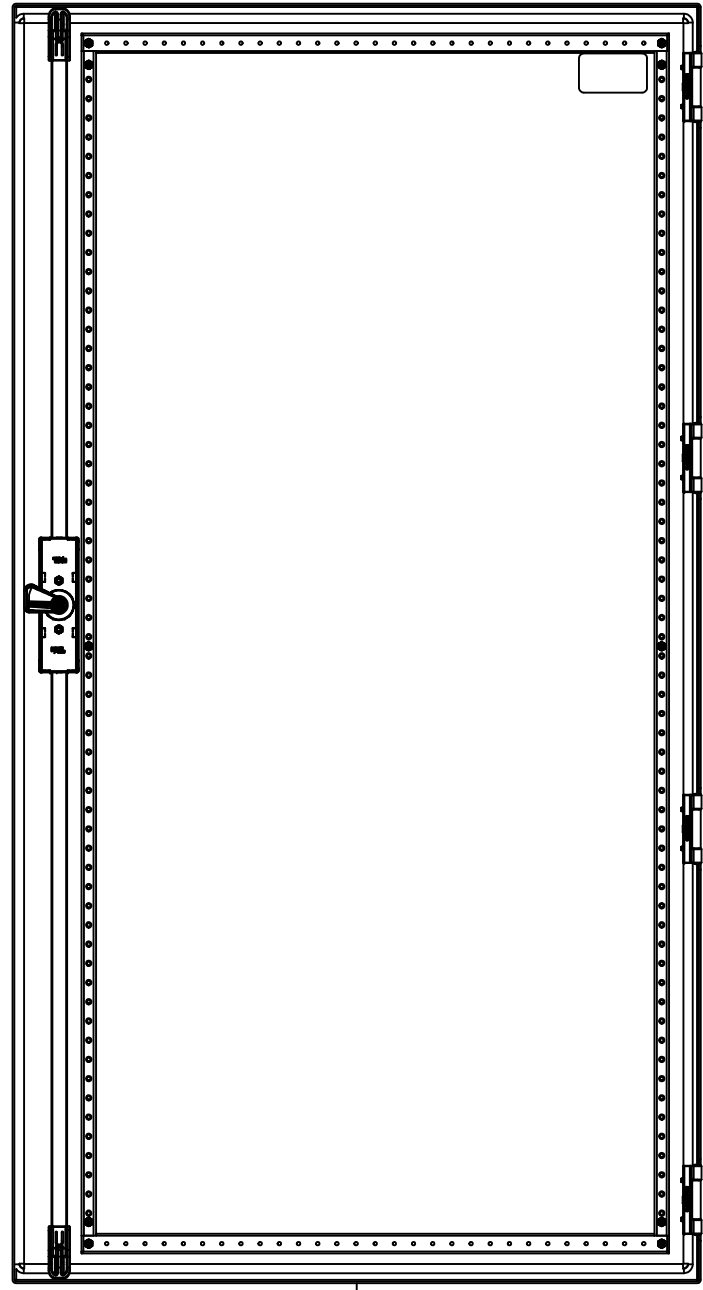

BACK



BOTTOM

0.000
0.835

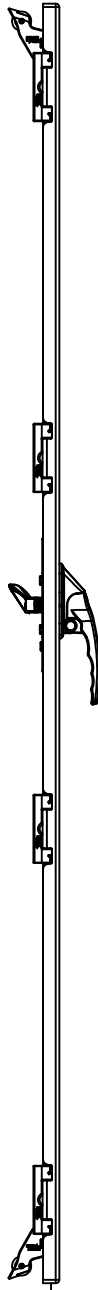

LEFT

0.000

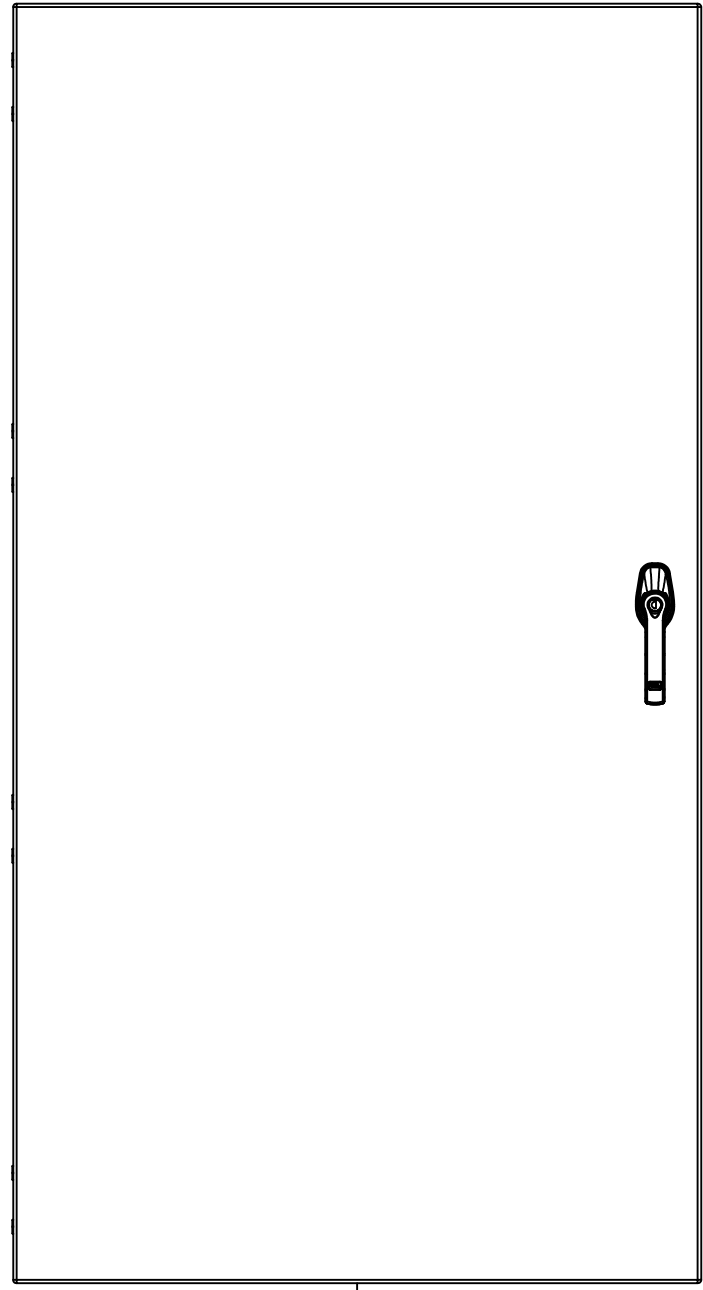

FRONT

35.312

65.549

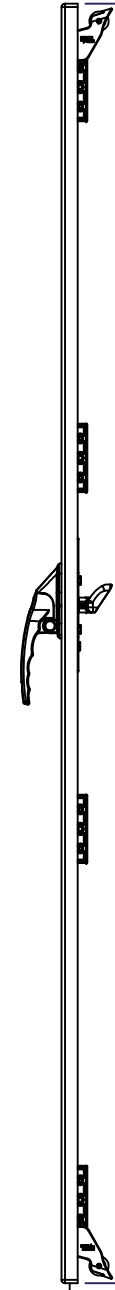

RIGHT

0.000

| No. | Revisions | Date | By/Par |
|-----|-----------|------|--------|
| | | | |
| | | | |
| | | | |
| | | | |

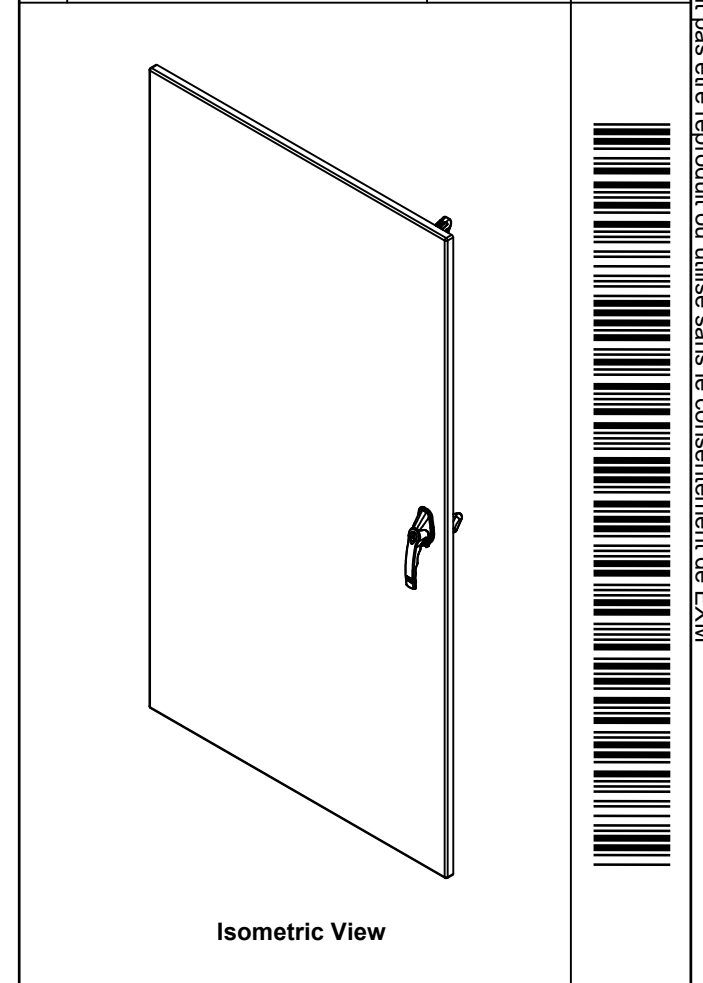

Isometric View



Tél: (450) 979-4373
Fax: (450) 979-4626
www.exmweb.com

Flatness
Aplatissement
Max 3.0mm
Projection

| | |
|---|-----------------|
| Customer Client | Date |
| Drawn By / Dessiné Par: BoxCad: BoxCad | Date: 2/12/2013 |
| Material / Matière: 12 Ga Cold Rolled A1008 CS Type B (2.5mm) | |

| | |
|------------------------------|-----------------------|
| Color / Couleur: Asa-61 Grey | Finish / Fini: Smooth |
|------------------------------|-----------------------|

| | |
|-----------------------------------|-------------|
| Description: 9500 72" x 36" Cover | Detail Rev. |
|-----------------------------------|-------------|

| | | |
|---|--------|-------|
| Part Number / Numéro Pièce: 9500723624C | Rev. 0 | 1 / 3 |
|---|--------|-------|

SEE BILL OF MATERIAL ON LAST PAGE

This drawing is confidential and must not be reproduced or used without the consent of EXM

Ce dessin est confidentiel et ne doit pas être reproduit ou utilisé sans le consentement de EXM

STANDARD FEATURES ARE NOT LISTED IN THIS HOLE TABLE

HOLE TABLE - FRONT VIEW (CUSTOM FEATURE ONLY)

| CUT-OUT | XDIM | YDIM | DESCRIPTION |
|---------|--------|--------|------------------------------|
| 1 | 2.000 | 2.028 | STUD M6 x 18mm (Inside) |
| 2 | 2.000 | 32.628 | STUD M6 x 18mm (Inside) |
| 3 | 2.000 | 63.521 | STUD M6 x 18mm (Inside) |
| 4 | 31.407 | 2.028 | STUD M6 x 18mm (Inside) |
| 5 | 31.407 | 32.628 | STUD M6 x 18mm (Inside) |
| 6 | 31.407 | 63.521 | STUD M6 x 18mm (Inside) |
| 7 | 2.000 | 3.139 | STUD M6 x 18mm (Inside) |
| 8 | 2.000 | 62.409 | STUD M6 x 18mm (Inside) |
| 9 | 31.407 | 3.139 | STUD M6 x 18mm (Inside) |
| 10 | 31.407 | 62.409 | STUD M6 x 18mm (Inside) |
| 11 | 32.937 | 6.118 | STUD M6 x 18mm (Inside) |
| 12 | 32.937 | 59.430 | STUD M6 x 18mm (Inside) |
| ----- | ----- | ----- | ----- |
| 13 | 32.937 | 34.743 | HANDLE 885 ESL2A-APHK @ 0.0° |

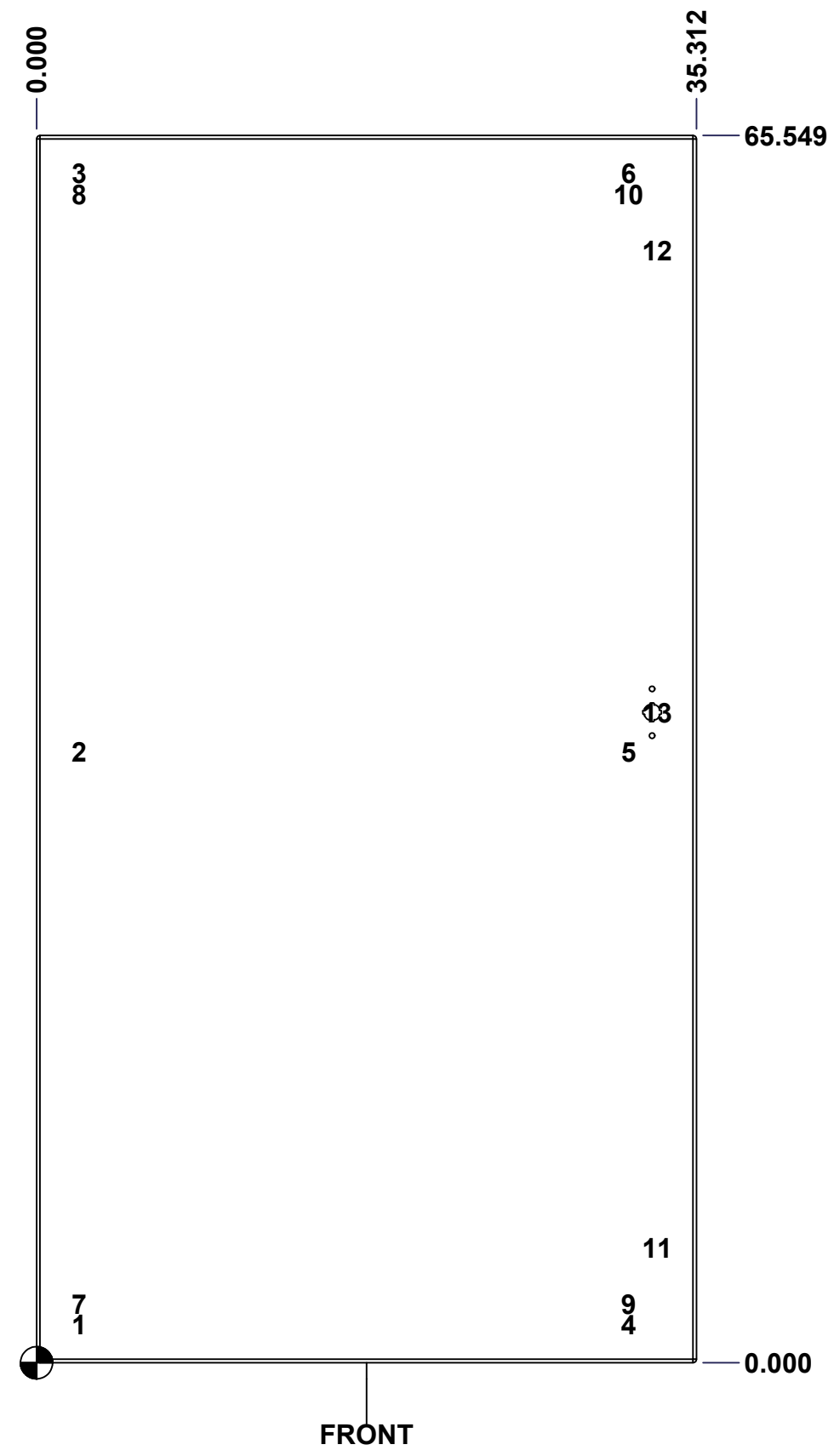

FRONT

| | | | |
|--|-----------------------------|----------|--------|
| | Description | Status | |
| | 9500 72" x 36" Cover | (NULL) | |
| | Part Number Numéro Pièce | Rev. | |
| | 9500723624C | 0 | 2 3 |

This drawing is confidential and must not be reproduced or used without the consent of EXM

Ce dessin est confidentiel et ne doit pas être reproduit ou utilisé sans le consentement de EXM

| No. | Revisions | Date | By/Par |
|-----|-----------|------|--------|
| | | | |
| | | | |
| | | | |
| | | | |
| | | | |

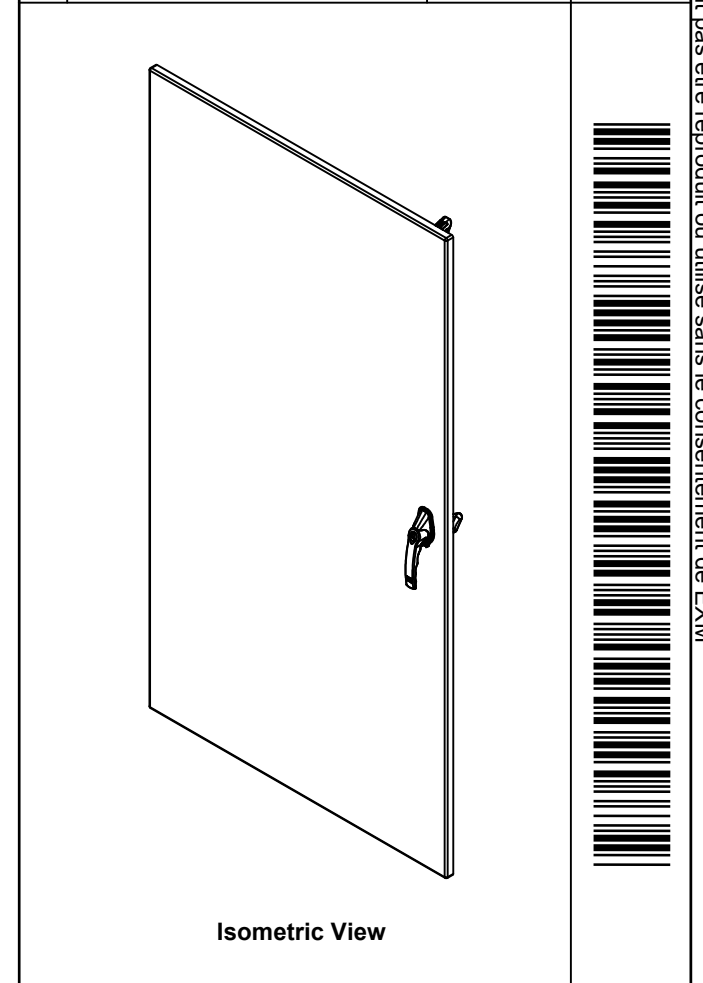

| 1 | STK-Q-47527 | 1 | 9500 Lower Closing Bar 72" |
|------------|----------------|-----|--|
| 1 | STK-Q-47517 | 1 | 9500 Upper Closing Bar 72" |
| 1 | STK-A-03886-36 | 2 | Gearbox Clockwise Assembly (36.0mm) |
| 1 | 885ESL2A-APHK | 6 | 885 ESL2A-APHK - Zinc Die Cast L-Handle Padlockable Assy |
| 1 | STK-P-02400S | 0 | Powder Paint (Asa-61 Grey / Smooth) |
| 1 | STK-S-00100 | 0 | 3.5" x 2" Silver Milar Flexcon Sticker |
| 1 | 9500723624G | 0 | 9500 72" x 36" Cover Gasket |
| 1 | STK-K-10850 | 3 | 9500 - Door Stiffener Assembly |
| 2 | STK-Q-16410 | 0 | Guide Stud - Largel (No Paint Cap Required) |
| 10 | STK-Q-16055 | 1 | M6 x 18mm Stud (No Paint Cap Required) |
| 1 | 9500723624C-P | 0 | 9500 72" x 36" Cover Part |
| 4 | STK-K-09860 | 7 | Cabinet Hinge with Captive Pins |
| 2 | STK-A-90025 | 0 | 9500 - Cabinet Closing Bar End (Large) |
| Qty | Part Name | Rev | Description |
| Parts List | | | |

| | | |
|--|---|-----------------------|
| Tél: (450) 979-4373 Fax: (450) 979-4626 www.exmweb.com | Flatness Aplatissement | Max 3.0mm |
| | Projection | |
| Customer Client | Date | |
| Drawn By Dessiné Par | BoxCad: BoxCad | Date 2/12/2013 |
| Material Matière | 12 Ga Cold Rolled A1008 CS Type B (2.5mm) | |
| Color Couleur | Asa-61 Grey | Finish Fini Smooth |
| Description | Detail Rev. | |
| 9500 72" x 36" Cover | | |
| Part Number Numéro Pièce | Rev. | 3 |
| 9500723624C | 0 | 3 |

All knockouts are actual size / Les disques défonçables sont grandeur réel
 All dimensions are before paint / Toutes les dimensions sont avant peinture

This drawing is confidential and must not be reproduced or used without the consent of EXM

Ce dessin est confidentiel et ne doit pas être reproduit ou utilisé sans le consentement de EXM

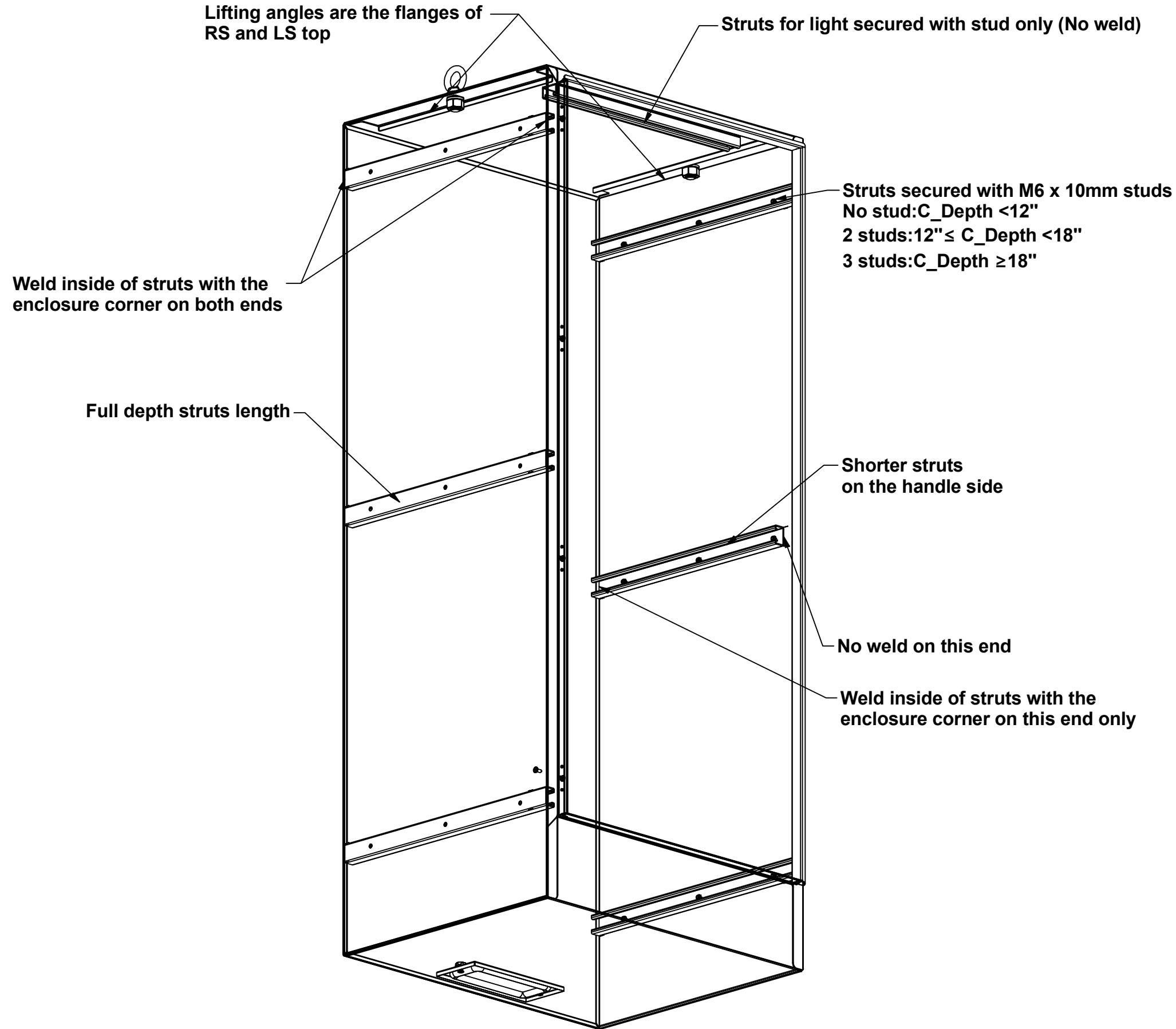

| No. | Revisions | Date | By/Par |
|-----|-----------|------|--------|
| | | | |
| | | | |
| | | | |
| | | | |

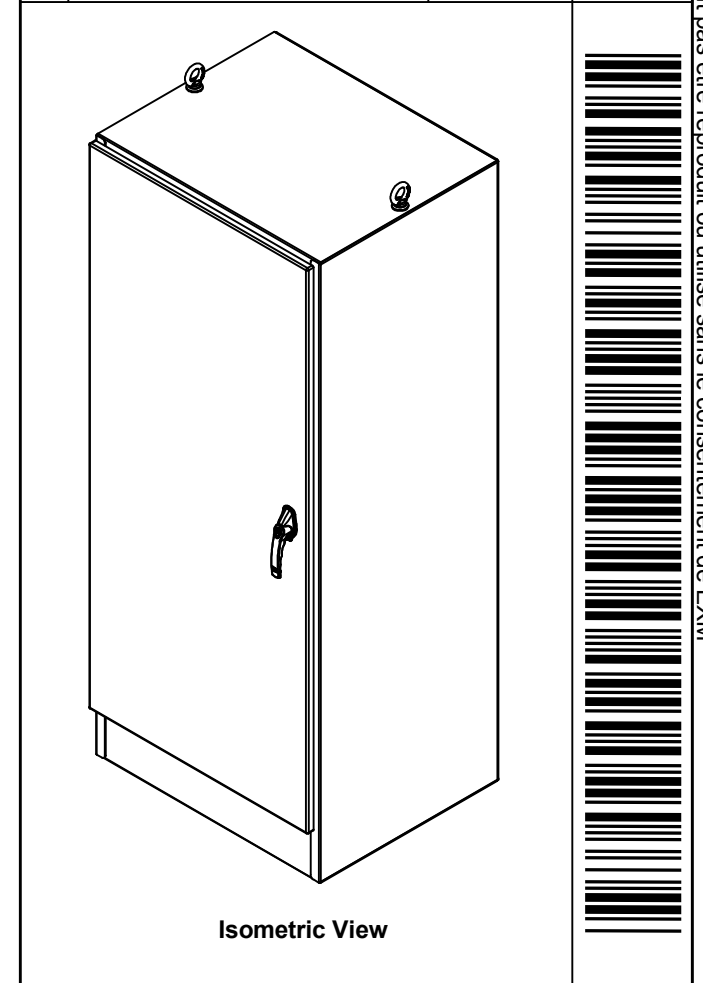

| | | |
|--|--------------------|---------------------------|
| Tél: (450) 979-4373 Fax: (450) 979-4626 www.exmweb.com | | Flatness Aplatissement |
| | | Max 3.0mm |
| Customer Client | | Date |
| Drawn By Dessiné Par PatrickD | | Date 3/9/2020 |
| Material Matière N/A | | |
| Color Couleur N/A | Finish Fini N/A | |
| Description 9500 Welding Detail | | Detail Rev. |
| Part Number Numéro Pièce 9500_WELDING_DETAIL | | Rev. 1 0 1 |