

This drawing is confidential and must not be reproduced or used without the consent of EXM

Ce dessin est confidentiel et ne doit pas être reproduit ou utilisé sans le consentement de EXM

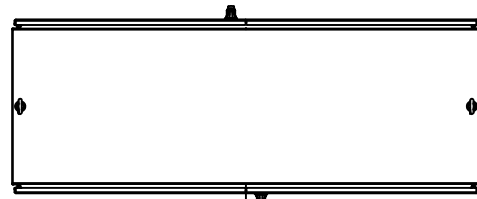

TOP

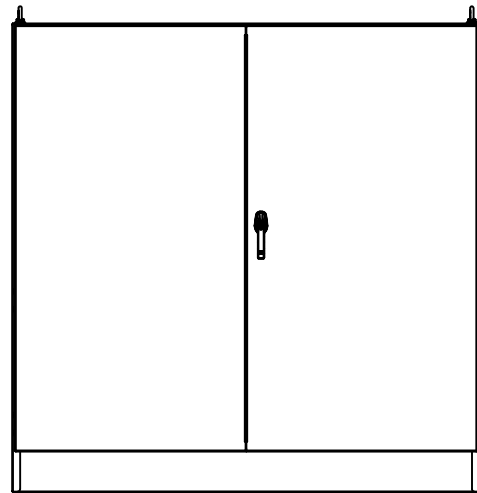

BACK

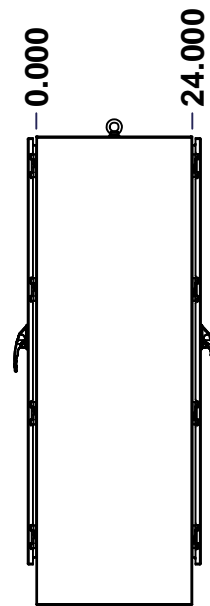

LEFT

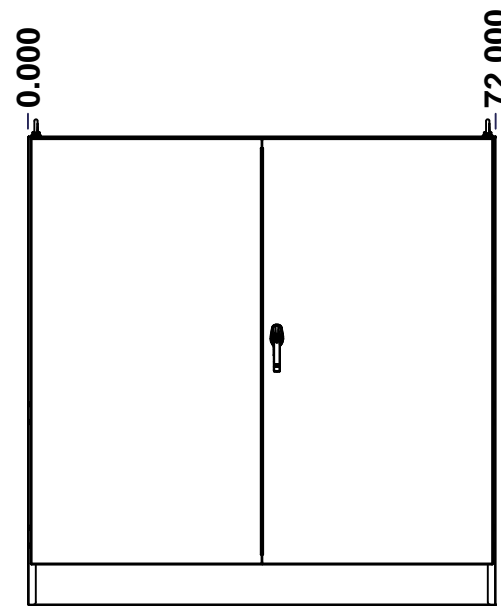

FRONT

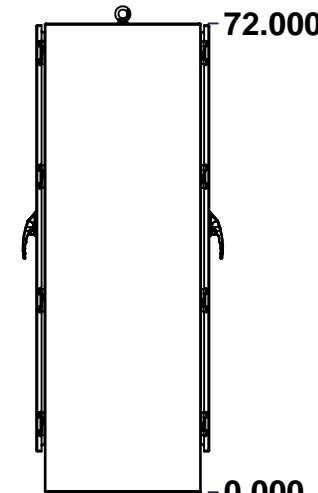

RIGHT

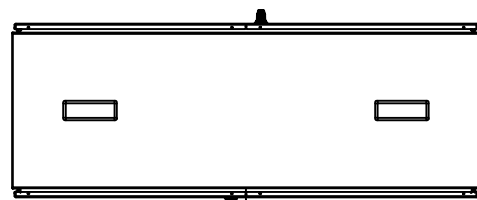

BOTTOM

No.	Revisions	Date	By/Par

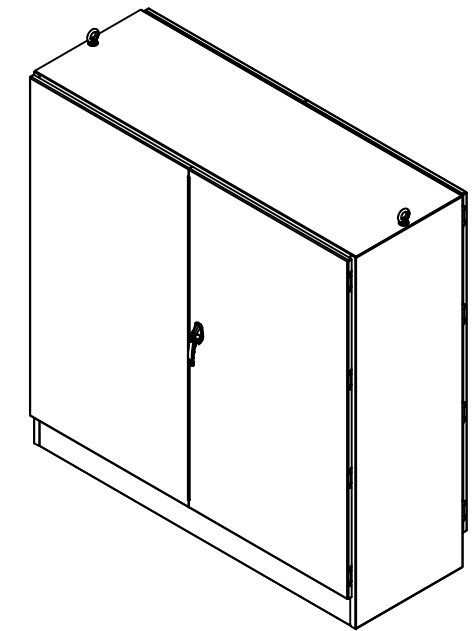

Isometric View



Tél: (450) 979-4373
 Fax: (450) 979-4626
www.exmweb.com

Flatness
Aplatissement

Max 3.0mm

Projection

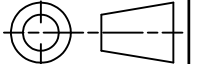

Customer Client	Date
Drawn By Dessiné Par BoxCad: BoxCad	Date 28-Oct-14
Material Matière 12 Ga Cold Rolled A1008 CS Type B (2.5mm)	
Color Couleur Asa-61 Grey	Finish Fini Smooth
Description 9500DADD 72" x 72" x 24" Assembly	Detail Rev.
Part Number Numéro Pièce 9500DADD727224	Rev. 1 0 2

SEE BILL OF MATERIAL ON LAST PAGE

This drawing is confidential and must not be reproduced or used without the consent of EXM

Ce dessin est confidentiel et ne doit pas être reproduit ou utilisé sans le consentement de EXM

NOTE	
ITEM	DESCRIPTION
1	NEMA 12/13 Enclosure
2	C/W Standard ground studs on box and cover
3	C/W Standard door stiffener
4	W/O Inner panel
5	C/W Standard inner panel mounting struts
6	C/W Eyebolts
7	C/W Struts installed (Included)

No.	Revisions	Date	By/Par

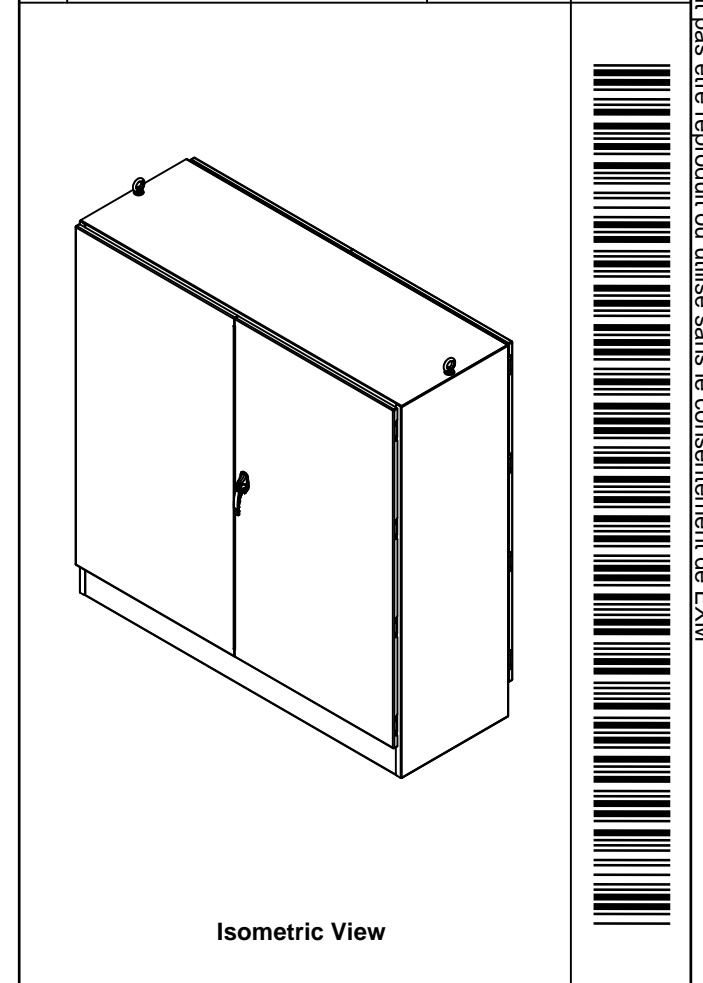

PACKING		
ITEM	QTY	DESCRIPTION
Cardboard sleeve	2	Top and Bottom
Cardboard strip	2	Between back of enclosure and inner panel
Plastic bag	1	To protect cover surface and inside gasket
Cardboard corner	4	To reinforced for the plastic strap tightening
Plastic strap - Black	2	To Squeeze 2 cardboard sleeve together
Packaging label	3	White label with PN
Plastic strap- Green	2	To secure the enclosure to the wood pallet
Wood Pallet	1	2" deeper and 3" larger than enclosure size

Qty	Part Number	Rev	Description
1	880EB14	2	Eye Bolt M14 (Pack of 2)
1	9500DADD727224FB	0	9500DADD 72" x 72" Back Flange Door
1	9500DADD727224LB	0	9500DADD 72" x 72" Back Lock Door
1	9500DADD727224FD	0	9500DADD 72" x 72" Front Flange Door
1	9500DADD727224LD	0	9500DADD 72" x 72" Front Lock Door
1	9500DADD727224B	0	9500DADD 72" x 72" x 24" Body
2	9500DADD727224GP	0	9500DADD Gland Plate
16	STK-Q-04050-10	8	M6 x 10mm Hexagon Socket Head Machine Screw with Nyseal
Parts List			

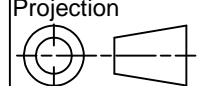
 Tél: (450) 979-4373 Fax: (450) 979-4626 www.exmweb.com		Flatness Aplatissement Max 3.0mm Projection 
Customer Client	BoxCad: BoxCad	Date 28-Oct-14
Material Matière	12 Ga Cold Rolled A1008 CS Type B (2.5mm)	
Color Couleur	Asa-61 Grey	Finish Fini Smooth
Description	9500DADD 72" x 72" x 24" Assembly	
Part Number Numéro Pièce	9500DADD727224	Rev. 0

This drawing is confidential and must not be reproduced or used without the consent of EXM

Ce dessin est confidentiel et ne doit pas être reproduit ou utilisé sans le consentement de EXM

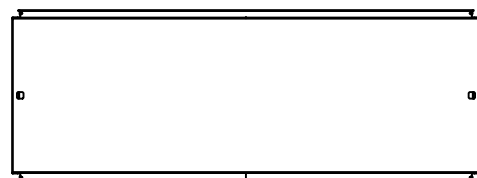

TOP

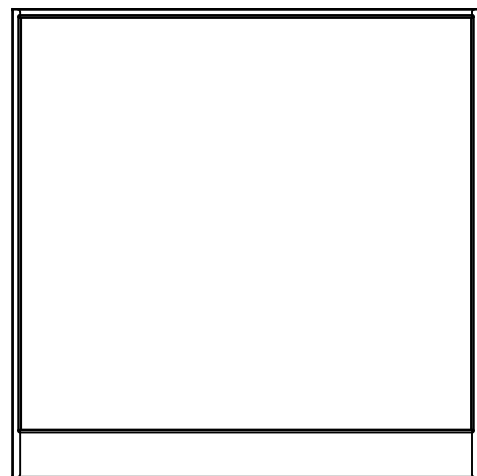

BACK

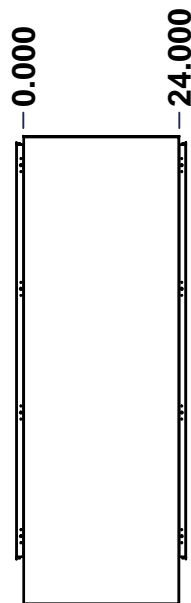

LEFT

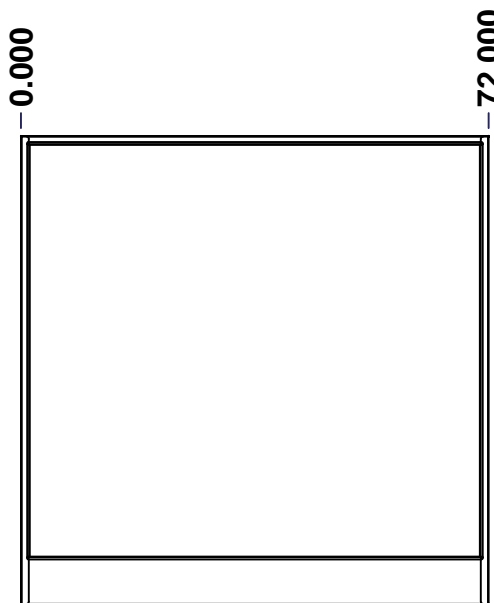

FRONT

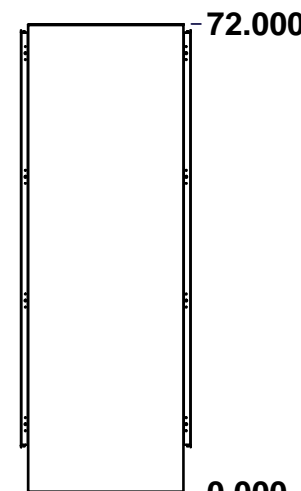

RIGHT

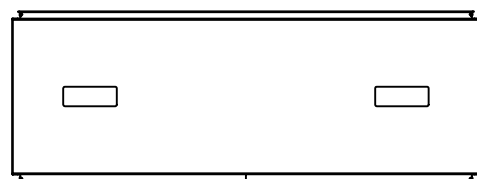

BOTTOM

No.	Revisions	Date	By/Par

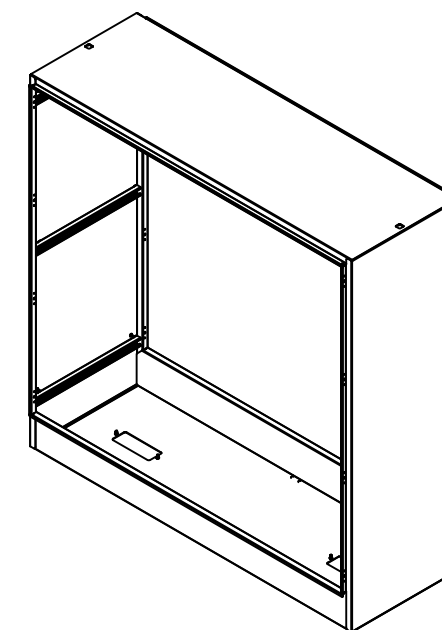

Isometric View



Tél: (450) 979-4373
 Fax: (450) 979-4626
www.exmweb.com

Flatness
Aplatissement

Max 3.0mm

Projection

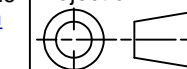

Customer Client	Date
Drawn By / Dessiné Par: BoxCad: BoxCad	Date: 28-Oct-14
Material / Matière: 12 Ga Cold Rolled A1008 CS Type B (2.5mm)	
Color / Couleur: Asa-61 Grey	Finish / Fini: Smooth
Description: 9500DADD 72" x 72" x 24" Body	Detail Rev.
Part Number / Numéro Pièce: 9500DADD727224B	Rev. 1 0

SEE BILL OF MATERIAL ON LAST PAGE

This drawing is confidential and must not be reproduced or used without the consent of EXM

Ce dessin est confidentiel et ne doit pas être reproduit ou utilisé sans le consentement de EXM

STANDARD FEATURES ARE NOT LISTED IN THIS HOLE TABLE

HOLE TABLE - TOP VIEW (CUSTOM FEATURE ONLY)

CUT-OUT	XDIM	YDIM	DESCRIPTION
1	17.911	20.000	Struts CR400 27.500" (Inside)
2	53.911	20.000	Struts CR400 27.500" (Inside)
3	17.911	20.000	STUDS M6 x 10mm (Inside)
4	7.161	20.000	STUDS M6 x 10mm (Inside)
5	28.661	20.000	STUDS M6 x 10mm (Inside)
6	53.911	20.000	STUDS M6 x 10mm (Inside)
7	43.161	20.000	STUDS M6 x 10mm (Inside)
8	64.661	20.000	STUDS M6 x 10mm (Inside)

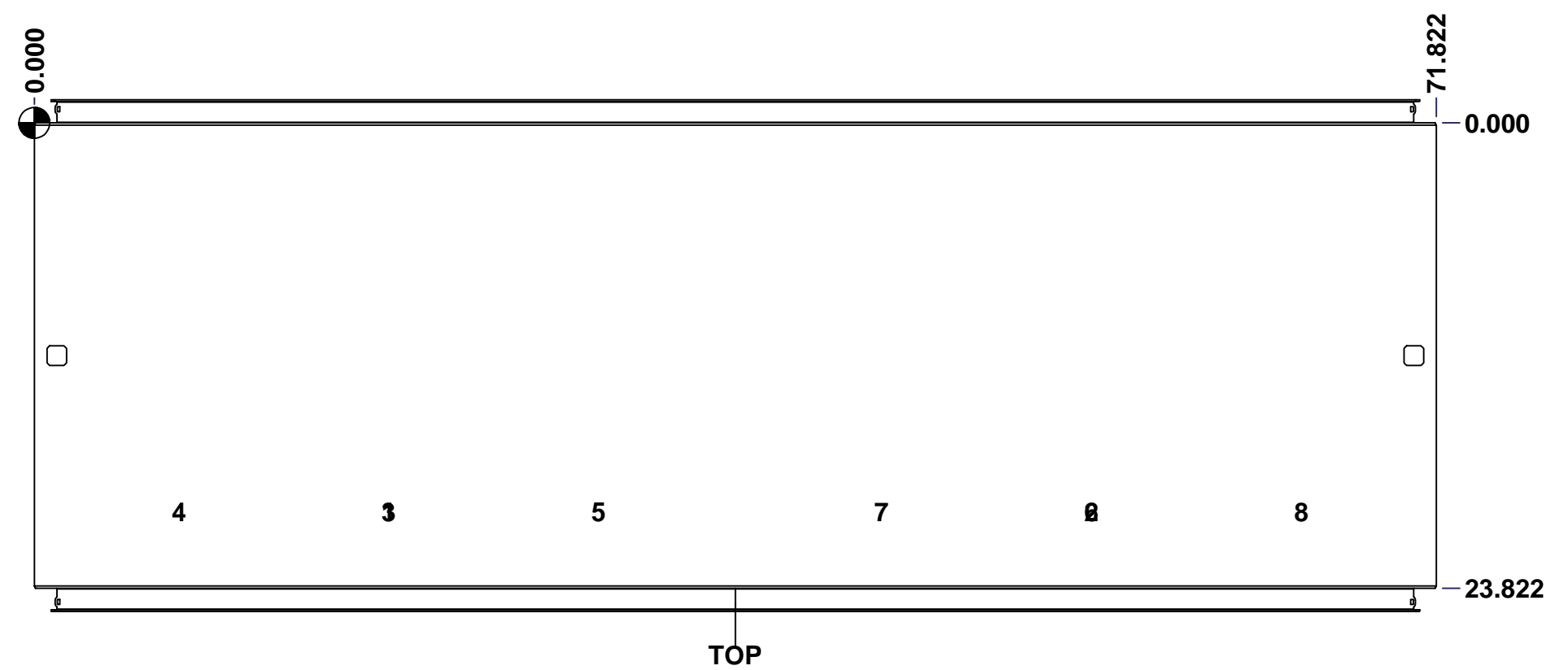

	Description	Status	
	9500DADD 72" x 72" x 24" Body	Released	
	Part Number Numéro Pièce	Rev.	
	9500DADD727224B	0	2 / 7

This drawing is confidential and must not be reproduced or used without the consent of EXM

Ce dessin est confidentiel et ne doit pas être reproduit ou utilisé sans le consentement de EXM

STANDARD FEATURES ARE NOT LISTED IN THIS HOLE TABLE

HOLE TABLE - RIGHT VIEW (CUSTOM FEATURE ONLY)

CUT-OUT	XDIM	YDIM	DESCRIPTION
1	1.500	10.286	GND STUD M6 x 16mm (Inside)
2	22.500	10.286	GND STUD M6 x 16mm (Inside)
3	3.250	67.036	STUDS M6 x 10mm (Inside)
4	20.750	67.036	STUDS M6 x 10mm (Inside)
5	12.000	67.036	STUDS M6 x 10mm (Inside)
6	3.250	8.786	STUDS M6 x 10mm (Inside)
7	20.750	8.786	STUDS M6 x 10mm (Inside)
8	12.000	8.786	STUDS M6 x 10mm (Inside)
9	3.250	37.911	STUDS M6 x 10mm (Inside)
10	20.750	37.911	STUDS M6 x 10mm (Inside)
11	12.000	37.911	STUDS M6 x 10mm (Inside)

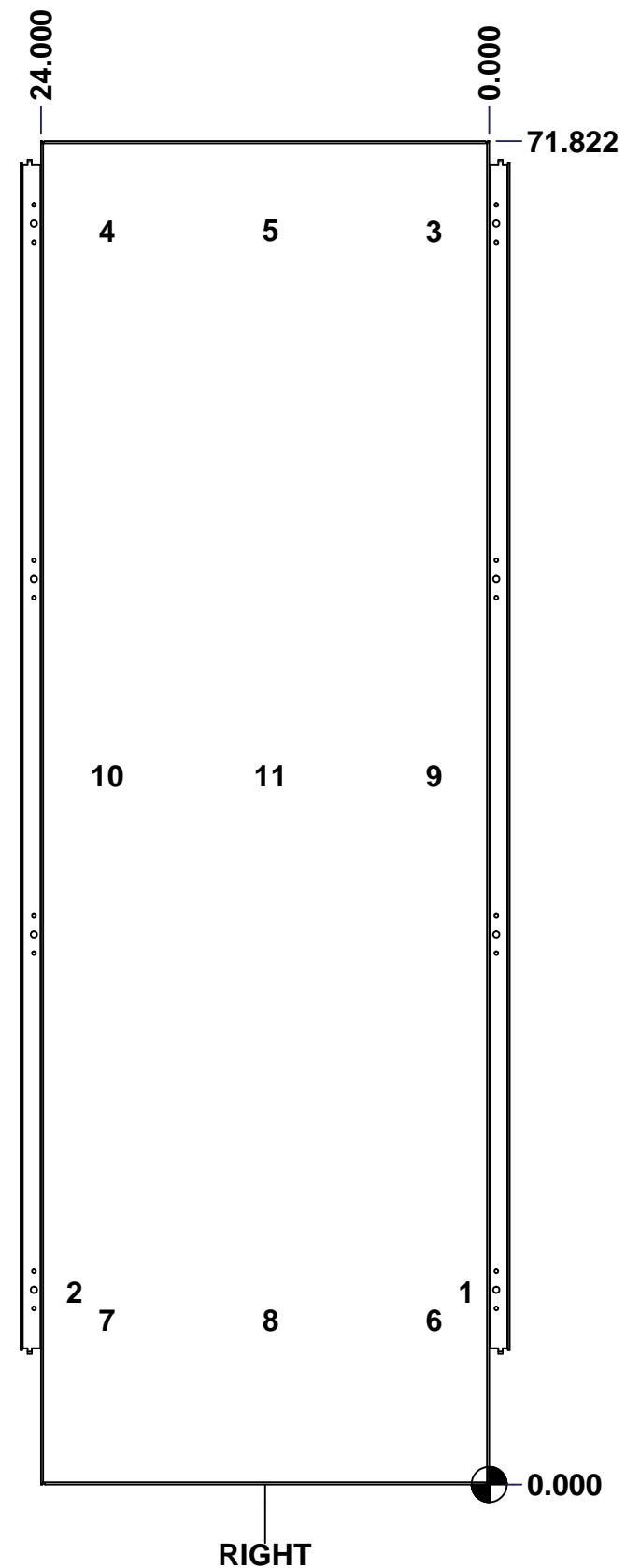

	Description		Status	
	9500DADD 72" x 72" x 24" Body		Released	
Part Number Numéro Pièce		Rev.	3	
9500DADD727224B		0	7	

This drawing is confidential and must not be reproduced or used without the consent of EXM

Ce dessin est confidentiel et ne doit pas être reproduit ou utilisé sans le consentement de EXM

STANDARD FEATURES ARE NOT LISTED IN THIS HOLE TABLE			
HOLE TABLE - BOTTOM VIEW (CUSTOM FEATURE ONLY)			
CUT-OUT	XDIM	YDIM	DESCRIPTION
1	7.286	12.000	GP STUD M6 x 16mm (Inside)
2	16.536	12.000	GP STUD M6 x 16mm (Inside)
3	55.286	12.000	GP STUD M6 x 16mm (Inside)
4	64.536	12.000	GP STUD M6 x 16mm (Inside)

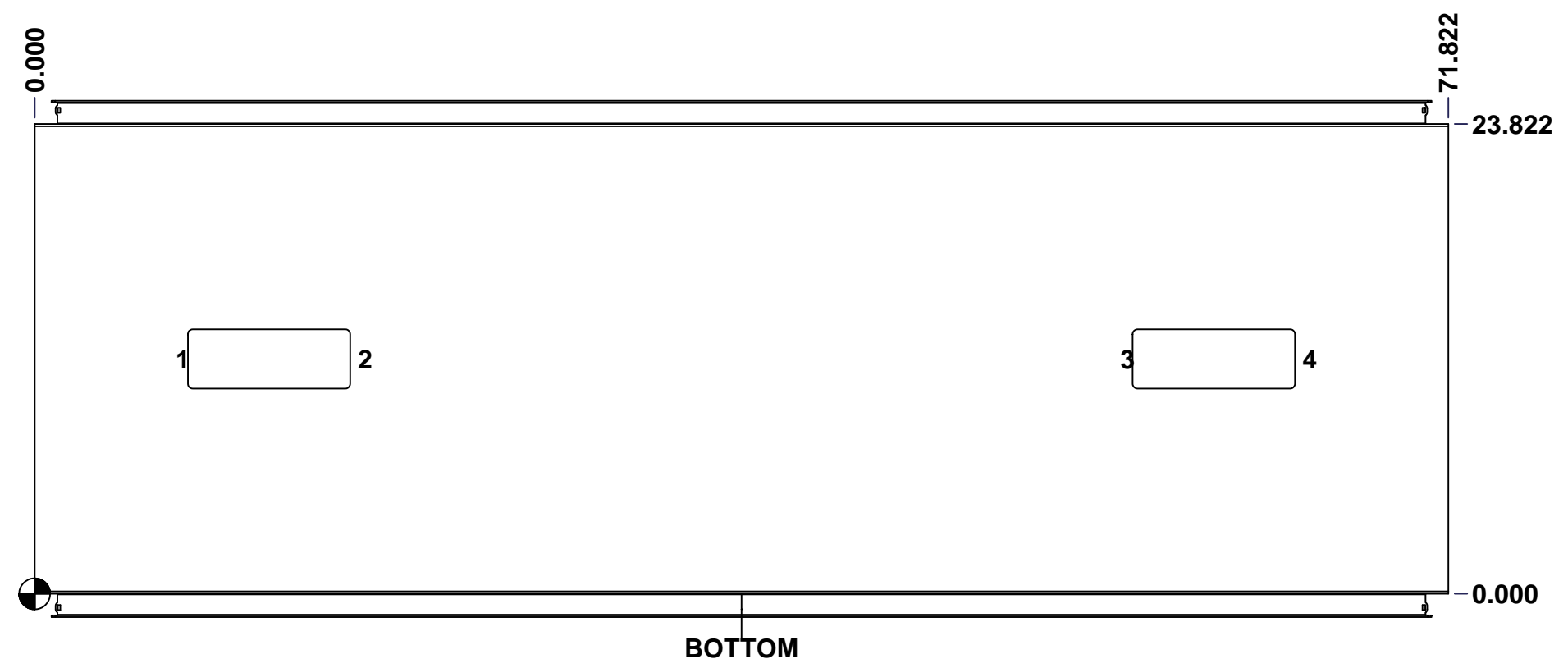

	Description	Status	
	9500DADD 72" x 72" x 24" Body	Released	
	Part Number Numéro Pièce	Rev.	
	9500DADD727224BB	0	4 / 7

This drawing is confidential and must not be reproduced or used without the consent of EXM

Ce dessin est confidentiel et ne doit pas être reproduit ou utilisé sans le consentement de EXM

STANDARD FEATURES ARE NOT LISTED IN THIS HOLE TABLE

HOLE TABLE - LEFT VIEW (CUSTOM FEATURE ONLY)

CUT-OUT	XDIM	YDIM	DESCRIPTION
1	1.411	10.286	GND STUD M6 x 16mm (Inside)
2	22.411	10.286	GND STUD M6 x 16mm (Inside)
3	3.161	67.036	STUDS M6 x 10mm (Inside)
4	20.661	67.036	STUDS M6 x 10mm (Inside)
5	11.911	67.036	STUDS M6 x 10mm (Inside)
6	3.161	8.786	STUDS M6 x 10mm (Inside)
7	20.661	8.786	STUDS M6 x 10mm (Inside)
8	11.911	8.786	STUDS M6 x 10mm (Inside)
9	3.161	37.911	STUDS M6 x 10mm (Inside)
10	20.661	37.911	STUDS M6 x 10mm (Inside)
11	11.911	37.911	STUDS M6 x 10mm (Inside)

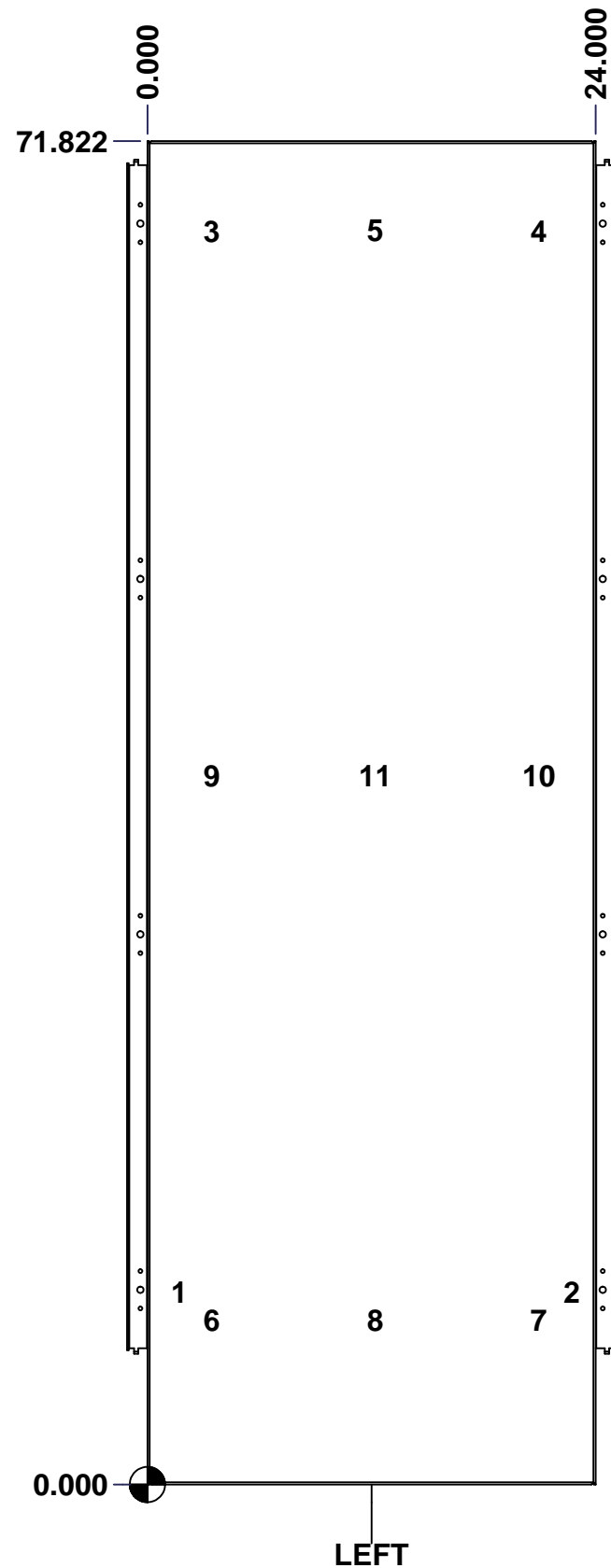

	Description	Status
	9500DADD 72" x 72" x 24" Body	Released
	Part Number Numéro Pièce	Rev.
	9500DADD727224B	0 / 5 / 7

This drawing is confidential and must not be reproduced or used without the consent of EXM

Ce dessin est confidentiel et ne doit pas être reproduit ou utilisé sans le consentement de EXM

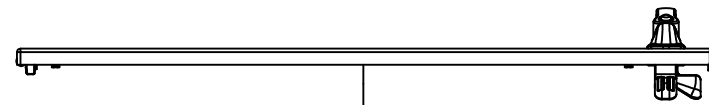

TOP

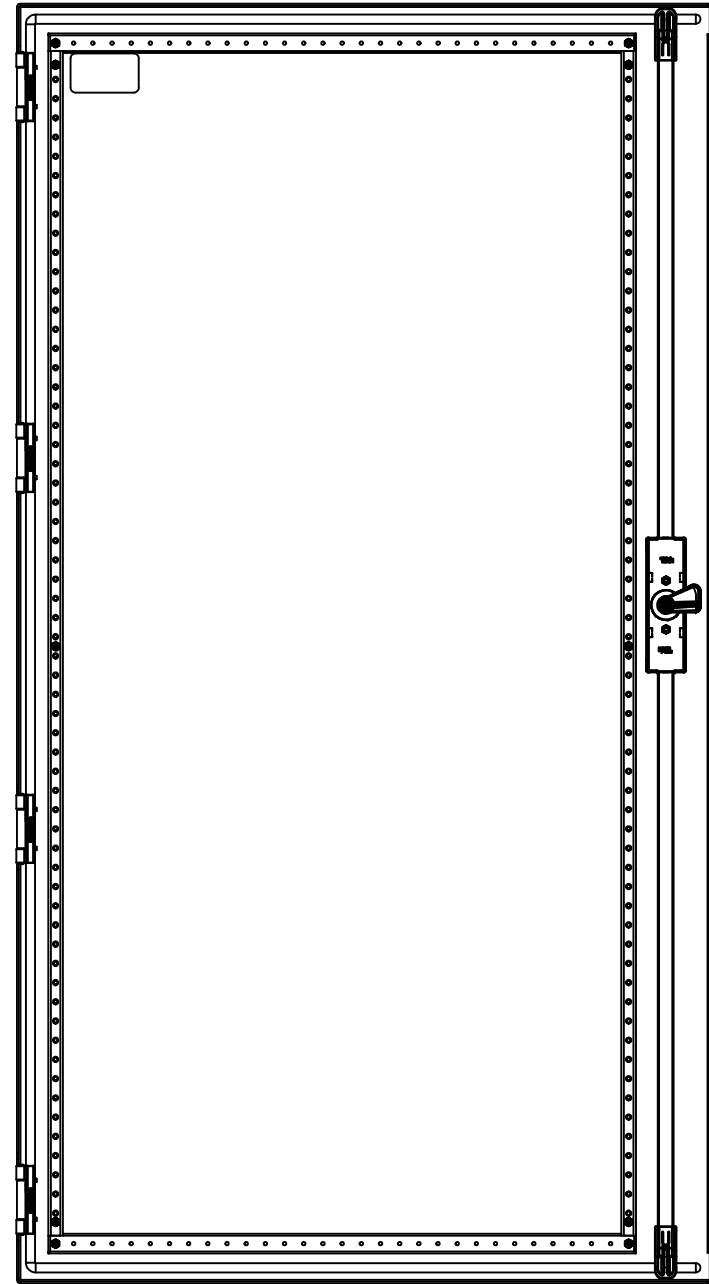

BACK



BOTTOM

0.000
0.835

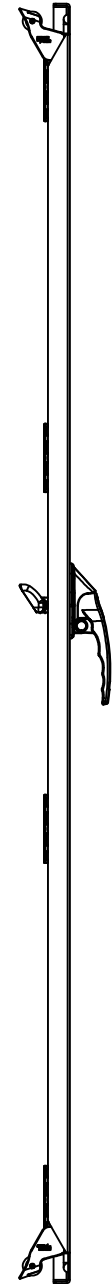

LEFT

35.561

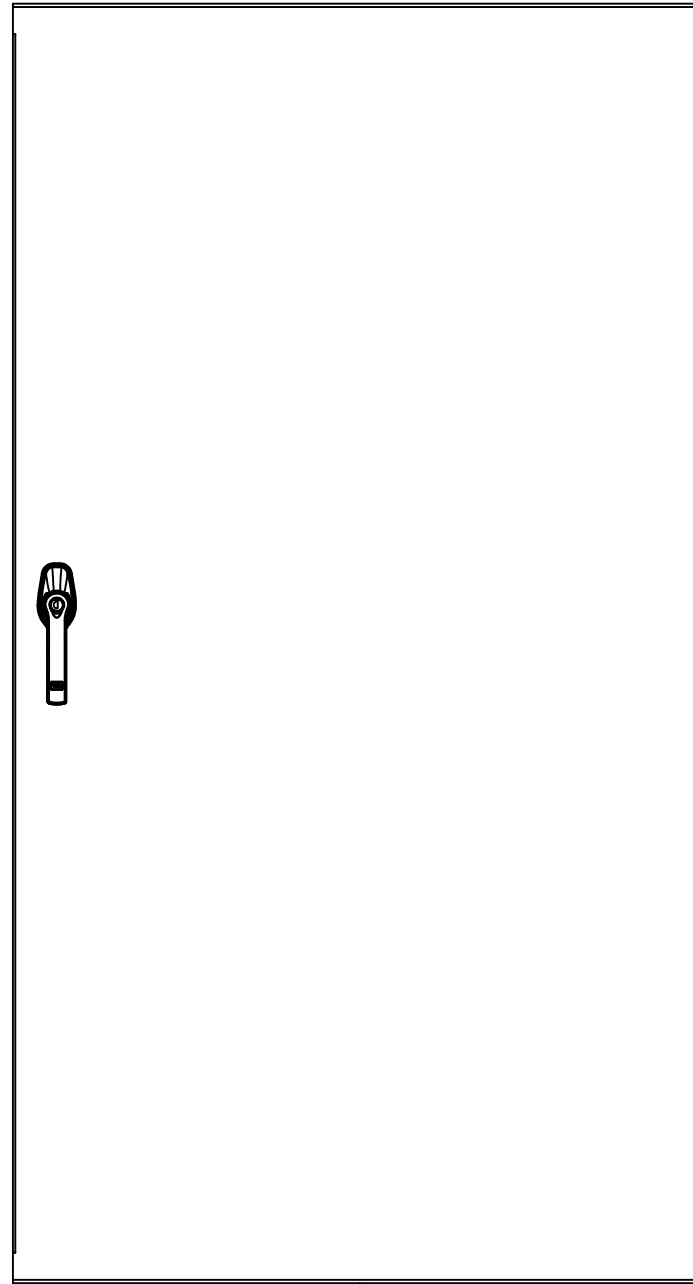

FRONT

0.000

65.549

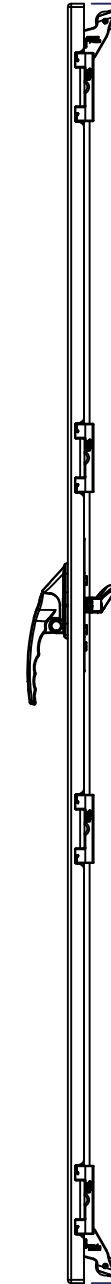

RIGHT

0.000

No.	Revisions	Date	By/Par

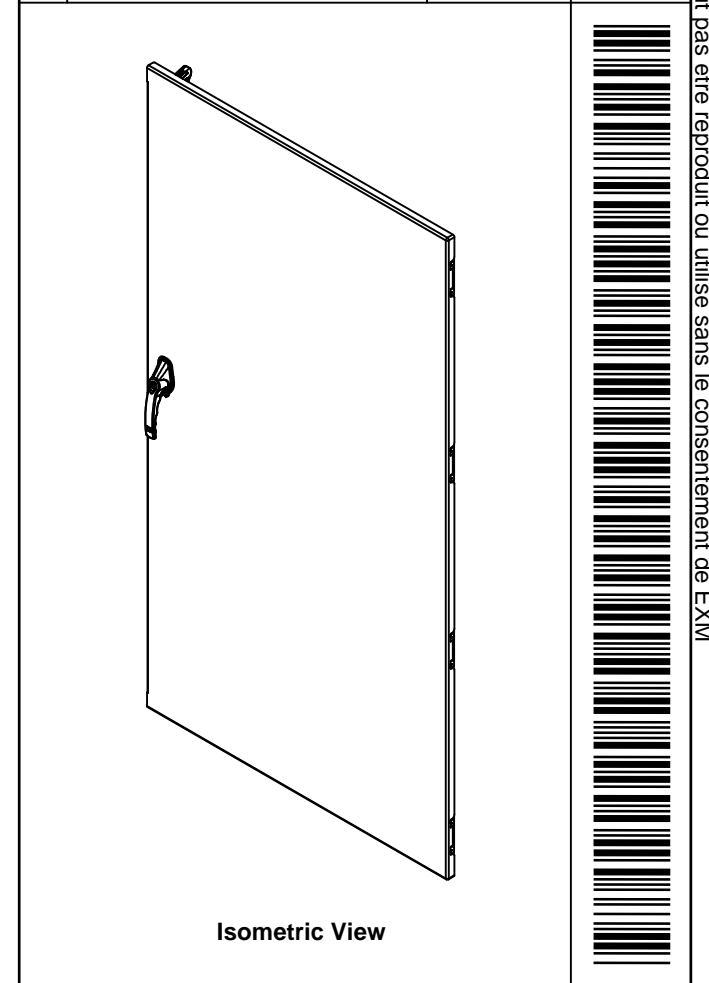

Tél: (450) 979-4373 Fax: (450) 979-4626 www.exmweb.com		Flatness Aplatissement	
		Max 3.0mm	
Customer Client		Date	
Drawn By Dessiné Par BoxCad: BoxCad		Date 28-Oct-14	
Material Matière 12 Ga Cold Rolled A1008 CS Type B (2.5mm)			
Color Couleur Asa-61 Grey		Finish Fini Smooth	
Description 9500DADD 72" x 72" Front Lock Door			Detail Rev.
Part Number Numéro Pièce 9500DADD727224LD		Rev. 0	1 3

SEE BILL OF MATERIAL ON LAST PAGE

This drawing is confidential and must not be reproduced or used without the consent of EXM

Ce dessin est confidentiel et ne doit pas être reproduit ou utilisé sans le consentement de EXM

STANDARD FEATURES ARE NOT LISTED IN THIS HOLE TABLE

HOLE TABLE - FRONT VIEW (CUSTOM FEATURE ONLY)

CUT-OUT	XDIM	YDIM	DESCRIPTION
1	1.983	2.028	STUD M6 x 18mm (Inside)
2	1.983	32.628	STUD M6 x 18mm (Inside)
3	1.983	63.521	STUD M6 x 18mm (Inside)
4	1.983	3.139	STUD M6 x 18mm (Inside)
5	1.983	62.409	STUD M6 x 18mm (Inside)
6	31.390	2.028	STUD M6 x 18mm (Inside)
7	31.390	32.628	STUD M6 x 18mm (Inside)
8	31.390	63.521	STUD M6 x 18mm (Inside)
9	31.390	3.139	STUD M6 x 18mm (Inside)
10	31.390	62.409	STUD M6 x 18mm (Inside)
11	33.311	6.118	STUD M6 x 18mm (Inside)
12	33.311	59.430	STUD M6 x 18mm (Inside)
-----	-----	-----	-----
13	33.311	34.743	HANDLE 885 ESL2A-APHK @ 0.0°

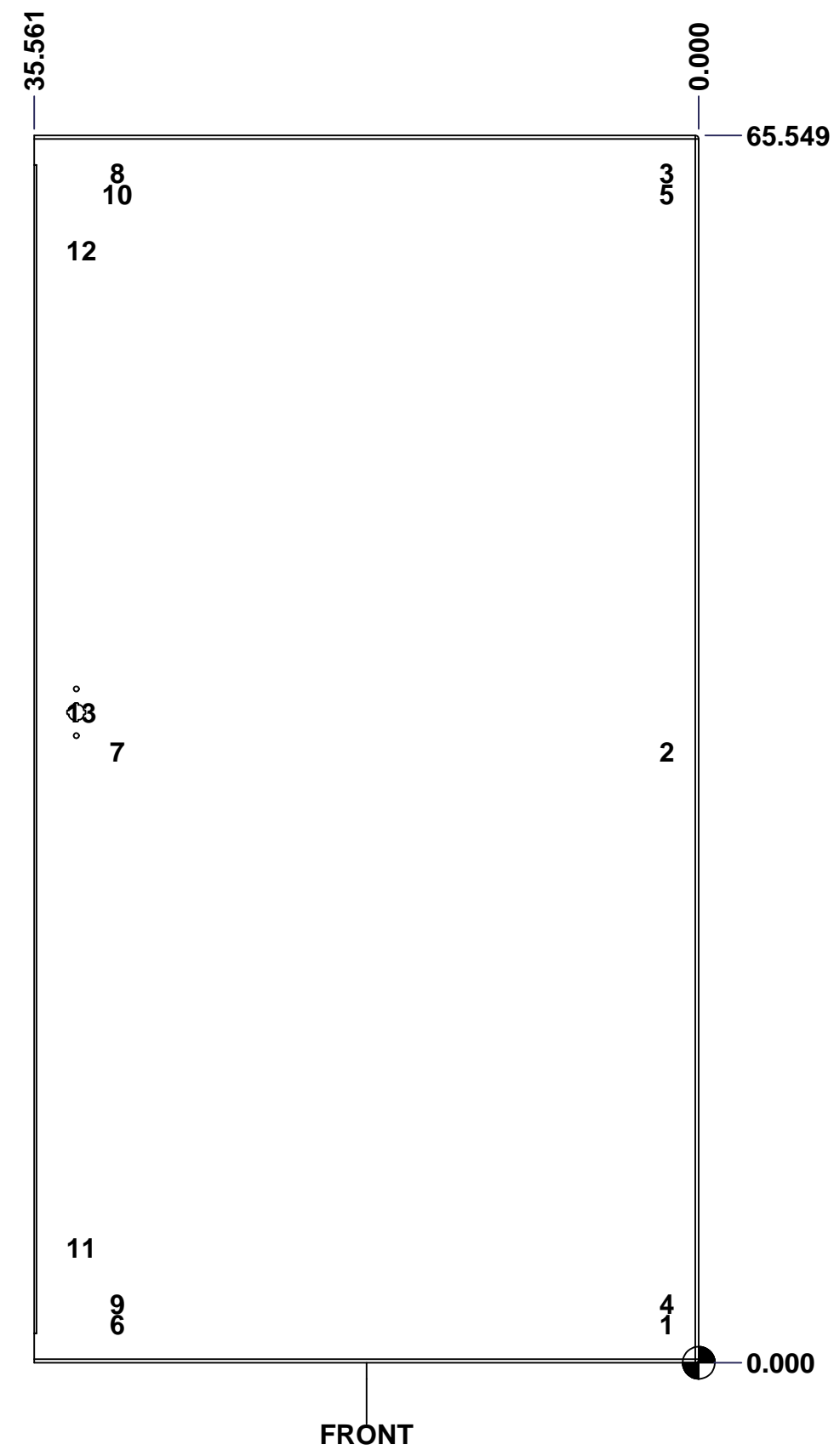

FRONT

	Description	Status
	9500DADD 72" x 72" Front Lock Door	(NULL)
	Part Number Numéro Pièce	Rev.
	9500DADD727224LD	0
		2
		3

This drawing is confidential and must not be reproduced or used without the consent of EXM

Ce dessin est confidentiel et ne doit pas être reproduit ou utilisé sans le consentement de EXM

No.	Revisions	Date	By/Par

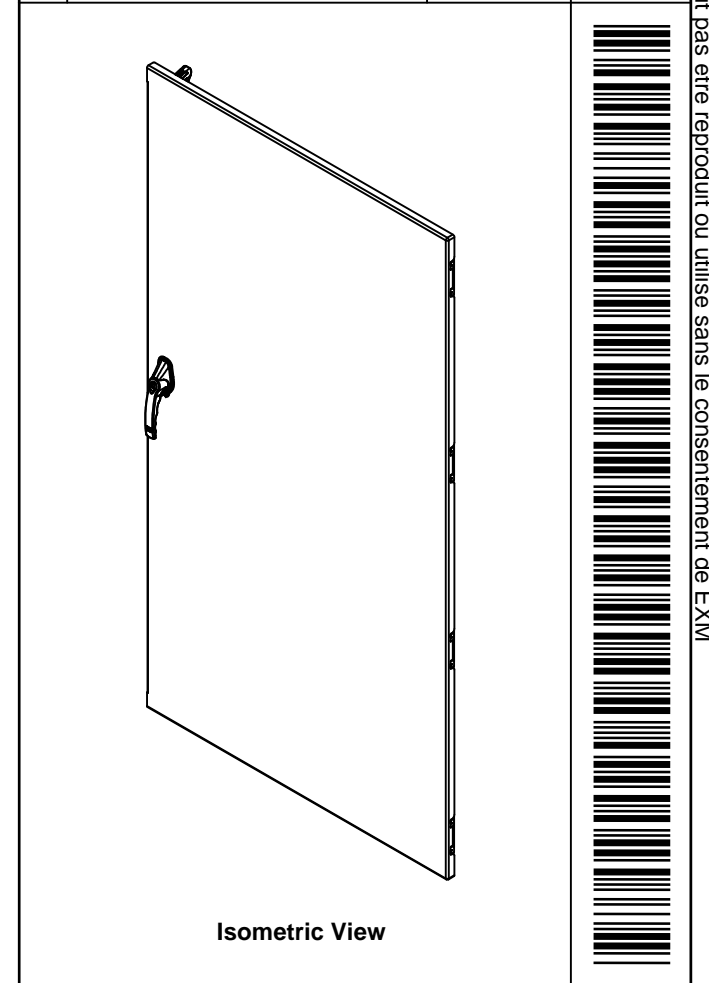

Qty	Part Name	Rev	Description
1	STK-Q-47527	1	9500 Lower Closing Bar 72"
1	STK-Q-47517	1	9500 Upper Closing Bar 72"
1	STK-A-03986-36	2	Gearbox Counterclockwise Assembly (36.0mm)
1	885ESL2A-APHK	6	885 ESL2A-APHK - Zinc Die Cast L-Handle Padlockable Assy
1	STK-P-02400S	0	Powder Paint (Asa-61 Grey / Smooth)
1	STK-S-00100	0	3.5" x 2" Silver Milar Flexcon Sticker
1	9500DADD727224LDG	0	9500DADD 72" x 72" Lock Door Gasket
1	STK-K-10850	3	9500 - Door Stiffener Assembly
2	STK-Q-16410	0	Guide Stud - Largel (No Paint Cap Required)
10	STK-Q-16055	1	M6 x 18mm Stud (No Paint Cap Required)
1	9500DADD727224LD-P	0	9500DADD 72" x 72" Front Lock Door Part
4	STK-K-09860	7	Cabinet Hinge with Captive Pins
2	STK-A-90025	0	9500 - Cabinet Closing Bar End (Large)

Tél: (450) 979-4373 Fax: (450) 979-4626 www.exmweb.com		Flatness Aplatissement Max 3.0mm Projection
Customer Client	Date	Date
Drawn By Dessiné Par	BoxCad: BoxCad	28-Oct-14
Material Matière	12 Ga Cold Rolled A1008 CS Type B (2.5mm)	
Color Couleur	Asa-61 Grey	Finish Fini: Smooth
Description	9500DADD 72" x 72" Front Lock Door	
Part Number Numéro Pièce	Rev.	3
9500DADD727224LD	0	3

Parts List

This drawing is confidential and must not be reproduced or used without the consent of EXM

Ce dessin est confidentiel et ne doit pas être reproduit ou utilisé sans le consentement de EXM



TOP

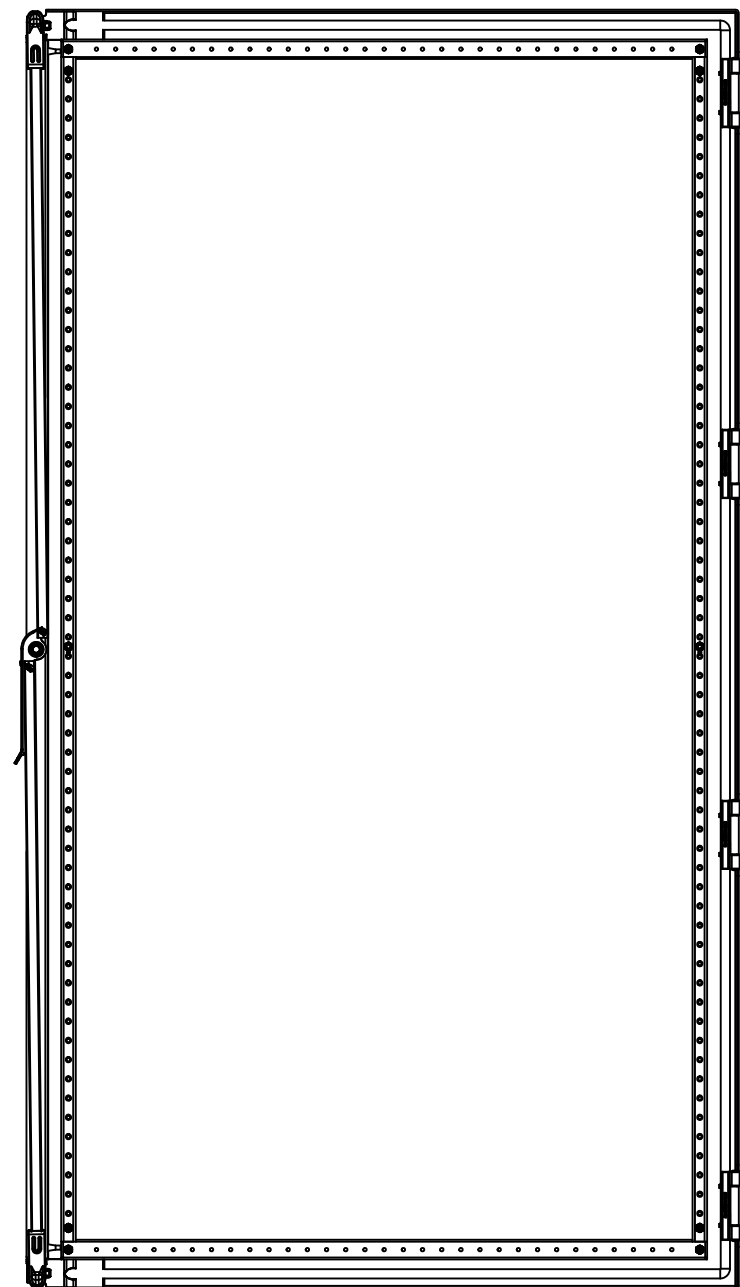

BACK



BOTTOM

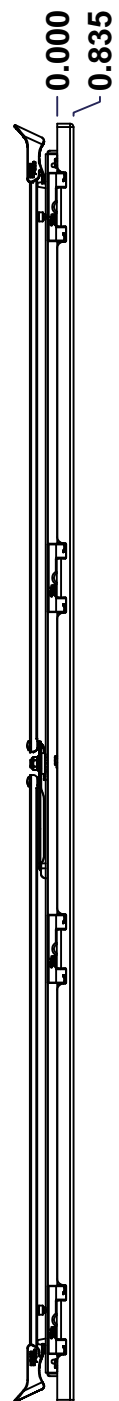

LEFT

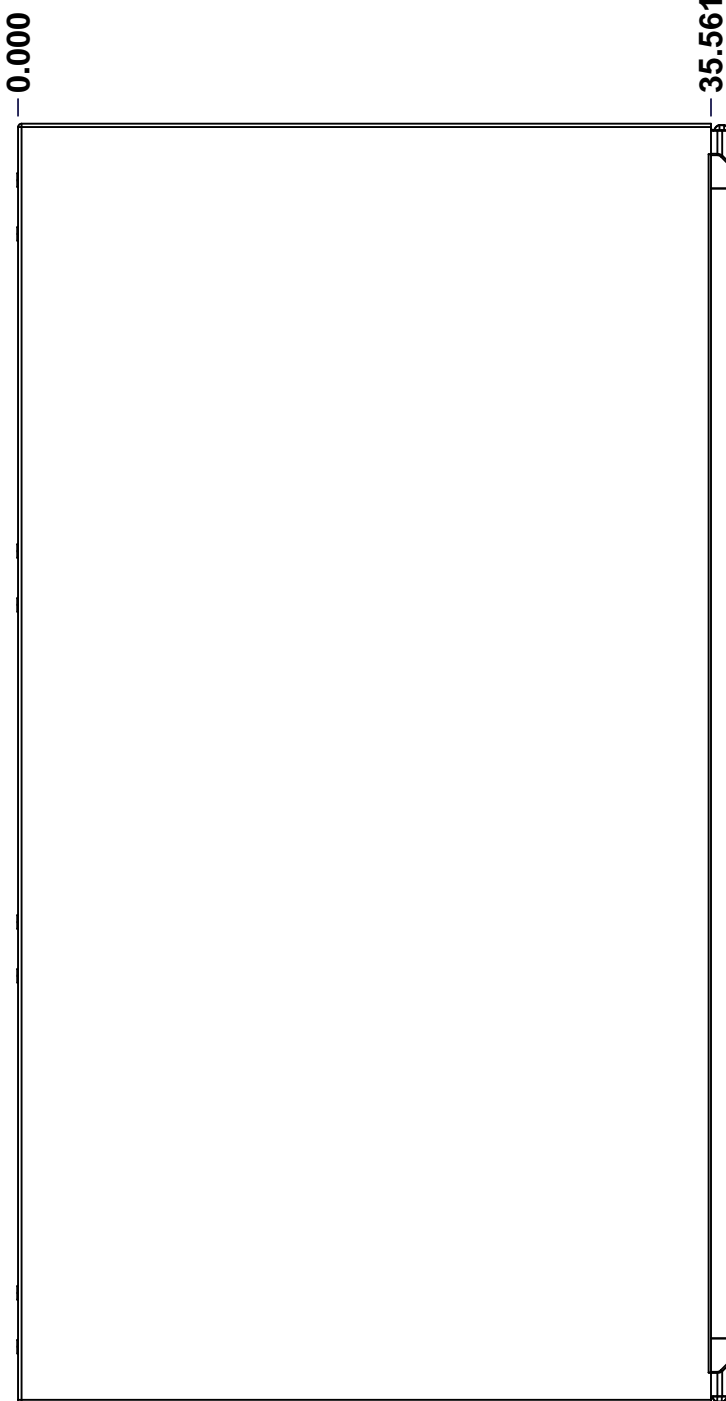

FRONT

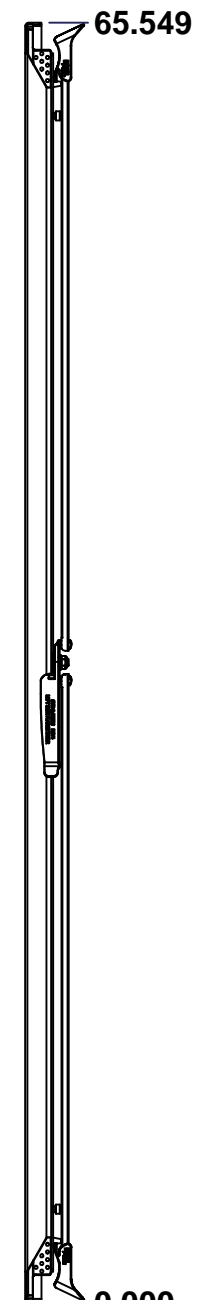

RIGHT

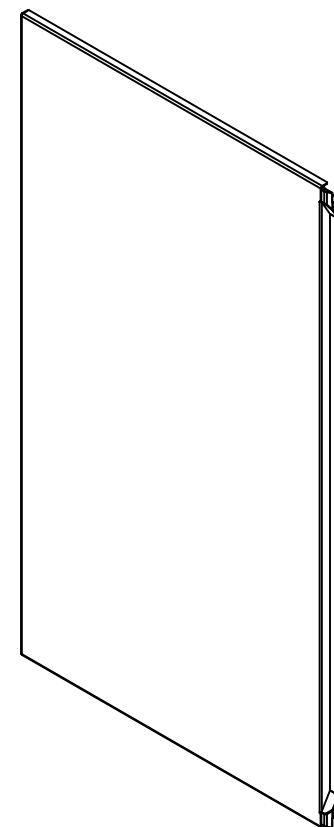

Isometric View

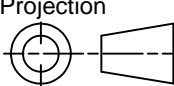

No.	Revisions	Date	By/Par

 Tél: (450) 979-4373 Fax: (450) 979-4626 www.exmweb.com		Flatness Aplatissement Max 3.0mm Projection 
Customer Client	Date	Date
Drawn By Dessiné Par	BoxCad: BoxCad	Date 28-Oct-14
Material Matière	12 Ga Cold Rolled A1008 CS Type B (2.5mm)	
Color Couleur	Asa-61 Grey	Finish Fini Smooth
Description	Detail Rev.	
9500DADD 72" x 72" Front Flange Door		
Part Number Numéro Pièce	Rev. 0	1 / 3

SEE BILL OF MATERIAL ON LAST PAGE

9500DADD727224FD

This drawing is confidential and must not be reproduced or used without the consent of EXM

Ce dessin est confidentiel et ne doit pas être reproduit ou utilisé sans le consentement de EXM

STANDARD FEATURES ARE NOT LISTED IN THIS HOLE TABLE

HOLE TABLE - FRONT VIEW (CUSTOM FEATURE ONLY)

CUT-OUT	XDIM	YDIM	DESCRIPTION
1	2.000	2.028	STUD M6 x 18mm (Inside)
2	2.000	32.628	STUD M6 x 18mm (Inside)
3	2.000	63.521	STUD M6 x 18mm (Inside)
4	2.000	3.139	STUD M6 x 18mm (Inside)
5	2.000	62.409	STUD M6 x 18mm (Inside)
6	34.407	2.028	STUD M6 x 18mm (Inside)
7	34.407	32.628	STUD M6 x 18mm (Inside)
8	34.407	63.521	STUD M6 x 18mm (Inside)
9	34.407	3.139	STUD M6 x 18mm (Inside)
10	34.407	62.409	STUD M6 x 18mm (Inside)
11	36.061	4.774	CLOSING BAR GUIDE (Inside)
12	36.061	60.774	CLOSING BAR GUIDE (Inside)
13	36.061	32.774	STUD M10 x 20mm (Inside)

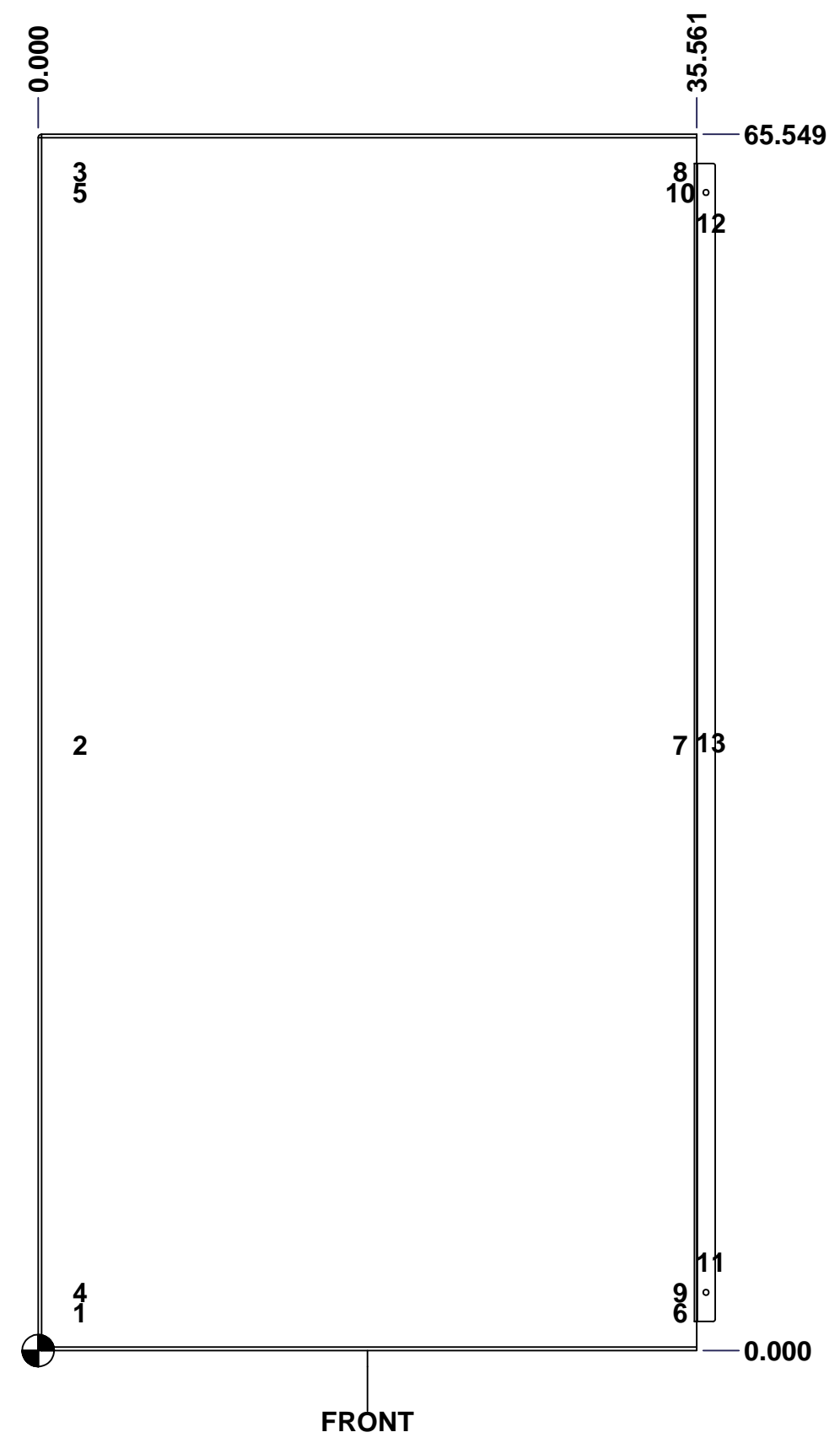

	Description		Status
	9500DADD 72" x 72" Front Flange Door		(NULL)
Part Number Numéro Pièce		Rev.	
9500DADD727224FD		0	2 3

This drawing is confidential and must not be reproduced or used without the consent of EXM

Ce dessin est confidentiel et ne doit pas être reproduit ou utilisé sans le consentement de EXM

No.	Revisions	Date	By/Par

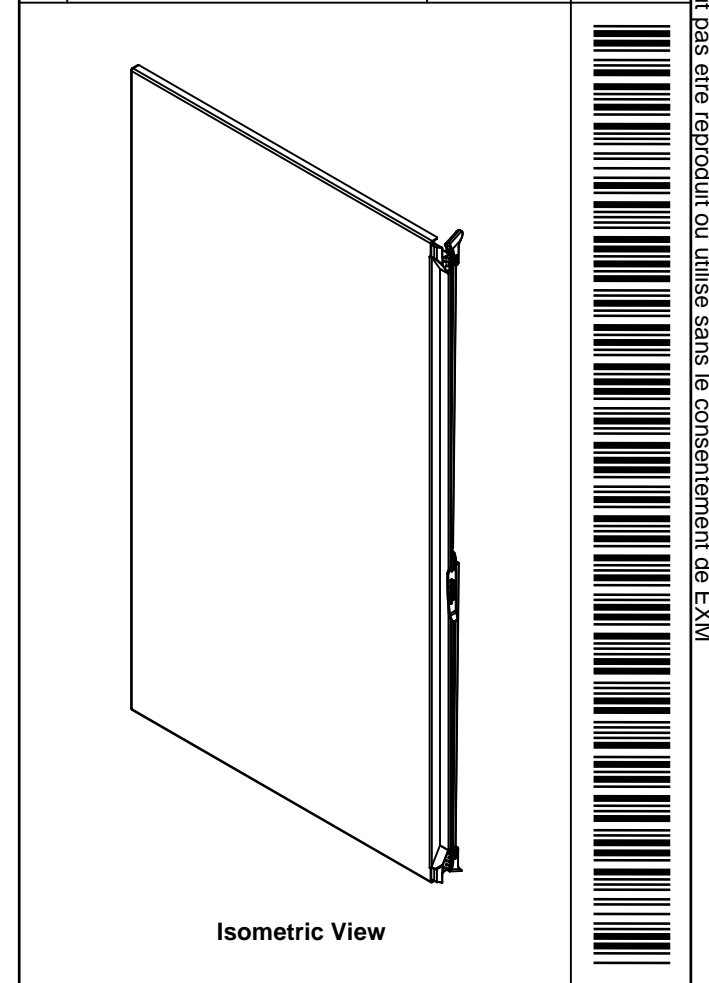

Qty	Part Name	Rev	Description
1	STK-P-02400S	0	Powder Paint (Asa-61 Grey / Smooth)
1	STK-G-03400	0	5500 DD Lower Flange Door Gasket
1	STK-G-03300	0	5500 DD Upper Flange Door Gasket
2	STK-Q-90045	0	Cabinet - Closing Bar End
2	STK-Q-45660-72	2	9500 DD - Flange Door Closing Bar
1	STK-K-50556	4	9500 DD - Flange Door Handle Assy
1	STK-K-20850	3	9500 - Flange Door Stiffener Assembly
1	STK-Q-16122	1	Stud M10 x 20mm
1	STK-G-00701	0	1" x 1/4" Self-Adhesive Neoprene Gasket
1	9500DADD727224FDG	0	9500DADD 72" x 72" Flange Door Gasket
2	STK-Q-16405	6	Guide Stud - Small (No Paint Cap Required)
10	STK-Q-16055	1	M6 x 18mm Stud (No Paint Cap Required)
1	9500DADD727224FD-P	0	9500DADD 72" x 72" Front Flange Door Part
4	STK-K-09860	7	Cabinet Hinge with Captive Pins
Qty	Part Name	Rev	Description
Parts List			

 Tél: (450) 979-4373 Fax: (450) 979-4626 www.exmweb.com		Flatness Aplatissement	
		Max 3.0mm	
Customer Client		Date	
Drawn By Dessiné Par BoxCad: BoxCad		Date 28-Oct-14	
Material Matière 12 Ga Cold Rolled A1008 CS Type B (2.5mm)		Projection	
Color Couleur Asa-61 Grey		Finish Fini Smooth	
Description 9500DADD 72" x 72" Front Flange Door			Detail Rev.
Part Number Numéro Pièce 9500DADD727224FD			Rev. 3
			0
			3

This drawing is confidential and must not be reproduced or used without the consent of EXM

Ce dessin est confidentiel et ne doit pas être reproduit ou utilisé sans le consentement de EXM



TOP

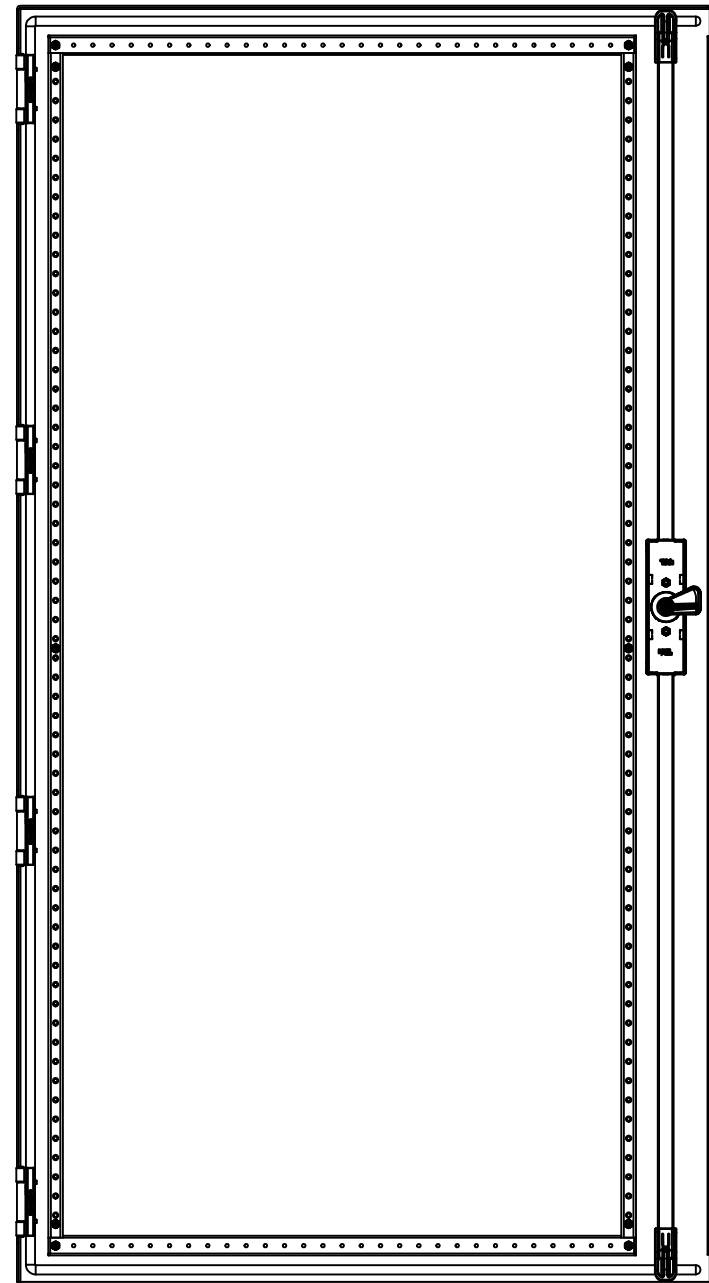

BACK



BOTTOM

0.000
0.835

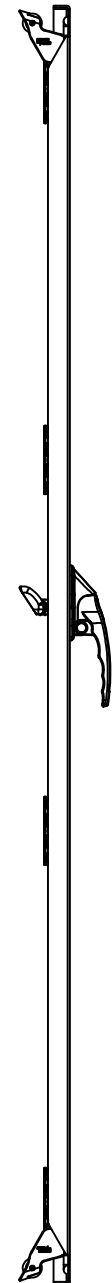

LEFT

35.561

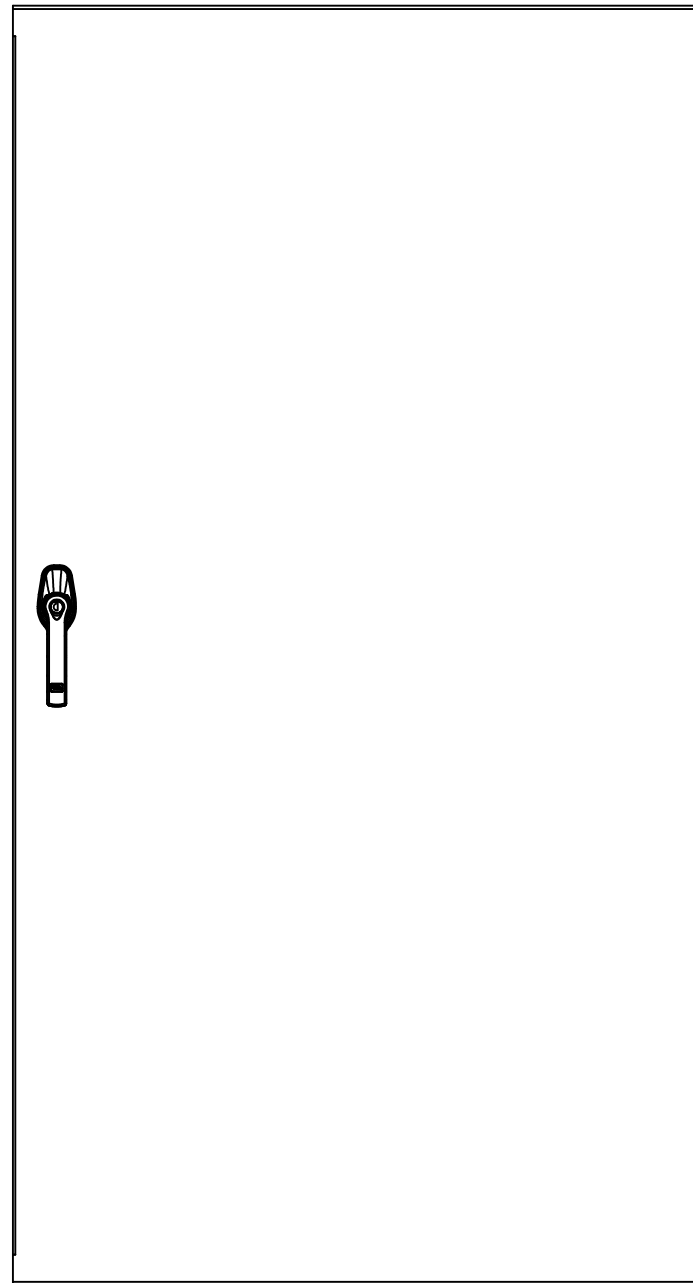

FRONT

0.000

65.549

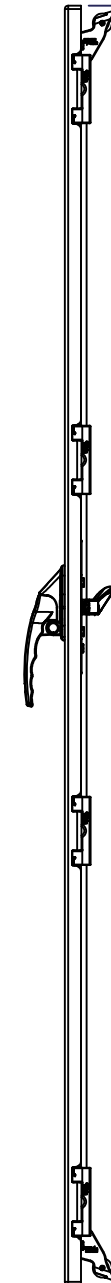

RIGHT

0.000

No.	Revisions	Date	By/Par

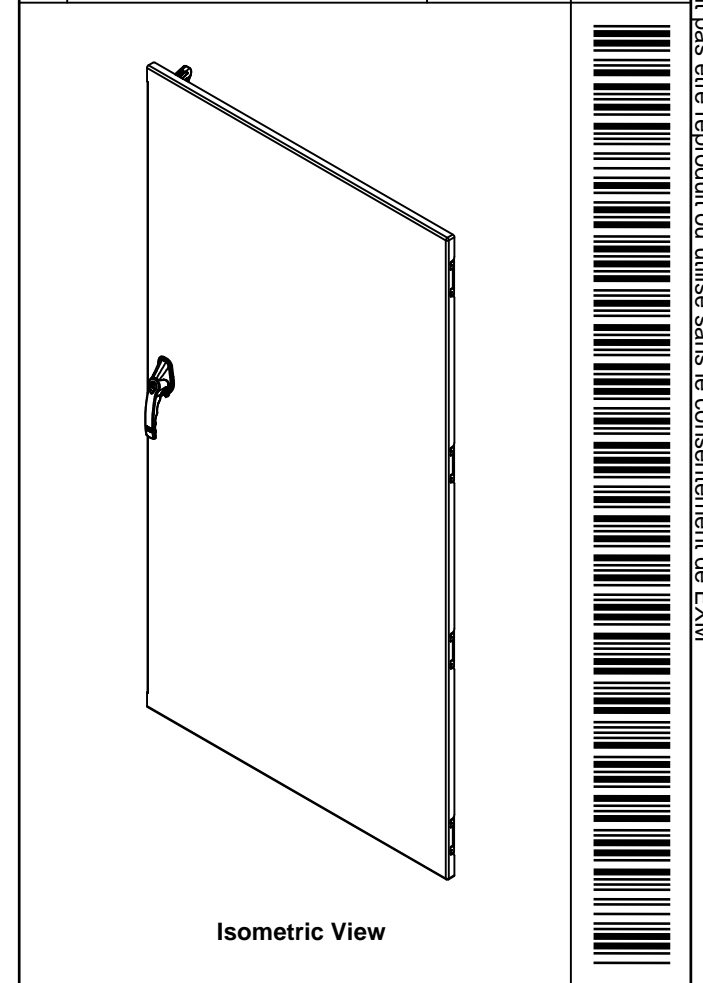

Tél: (450) 979-4373 Fax: (450) 979-4626 www.exmweb.com		Flatness Aplatissement	
		Max 3.0mm	
Customer Client		Date	
Drawn By Dessiné Par BoxCad: BoxCad		Date 28-Oct-14	
Material Matière 12 Ga Cold Rolled A1008 CS Type B (2.5mm)			
Color Couleur Asa-61 Grey		Finish Fini Smooth	
Description 9500DADD 72" x 72" Back Lock Door			Detail Rev.
Part Number Numéro Pièce 9500DADD727224LB		Rev. 0	1 3

SEE BILL OF MATERIAL ON LAST PAGE

This drawing is confidential and must not be reproduced or used without the consent of EXM

Ce dessin est confidentiel et ne doit pas être reproduit ou utilisé sans le consentement de EXM

STANDARD FEATURES ARE NOT LISTED IN THIS HOLE TABLE

HOLE TABLE - FRONT VIEW (CUSTOM FEATURE ONLY)

CUT-OUT	XDIM	YDIM	DESCRIPTION
1	1.983	2.028	STUD M6 x 18mm (Inside)
2	1.983	32.628	STUD M6 x 18mm (Inside)
3	1.983	63.521	STUD M6 x 18mm (Inside)
4	1.983	3.139	STUD M6 x 18mm (Inside)
5	1.983	62.409	STUD M6 x 18mm (Inside)
6	31.390	2.028	STUD M6 x 18mm (Inside)
7	31.390	32.628	STUD M6 x 18mm (Inside)
8	31.390	63.521	STUD M6 x 18mm (Inside)
9	31.390	3.139	STUD M6 x 18mm (Inside)
10	31.390	62.409	STUD M6 x 18mm (Inside)
11	33.311	6.118	STUD M6 x 18mm (Inside)
12	33.311	59.430	STUD M6 x 18mm (Inside)
-----	-----	-----	-----
13	33.311	34.743	HANDLE 885 ESL2A-APHK @ 0.0°

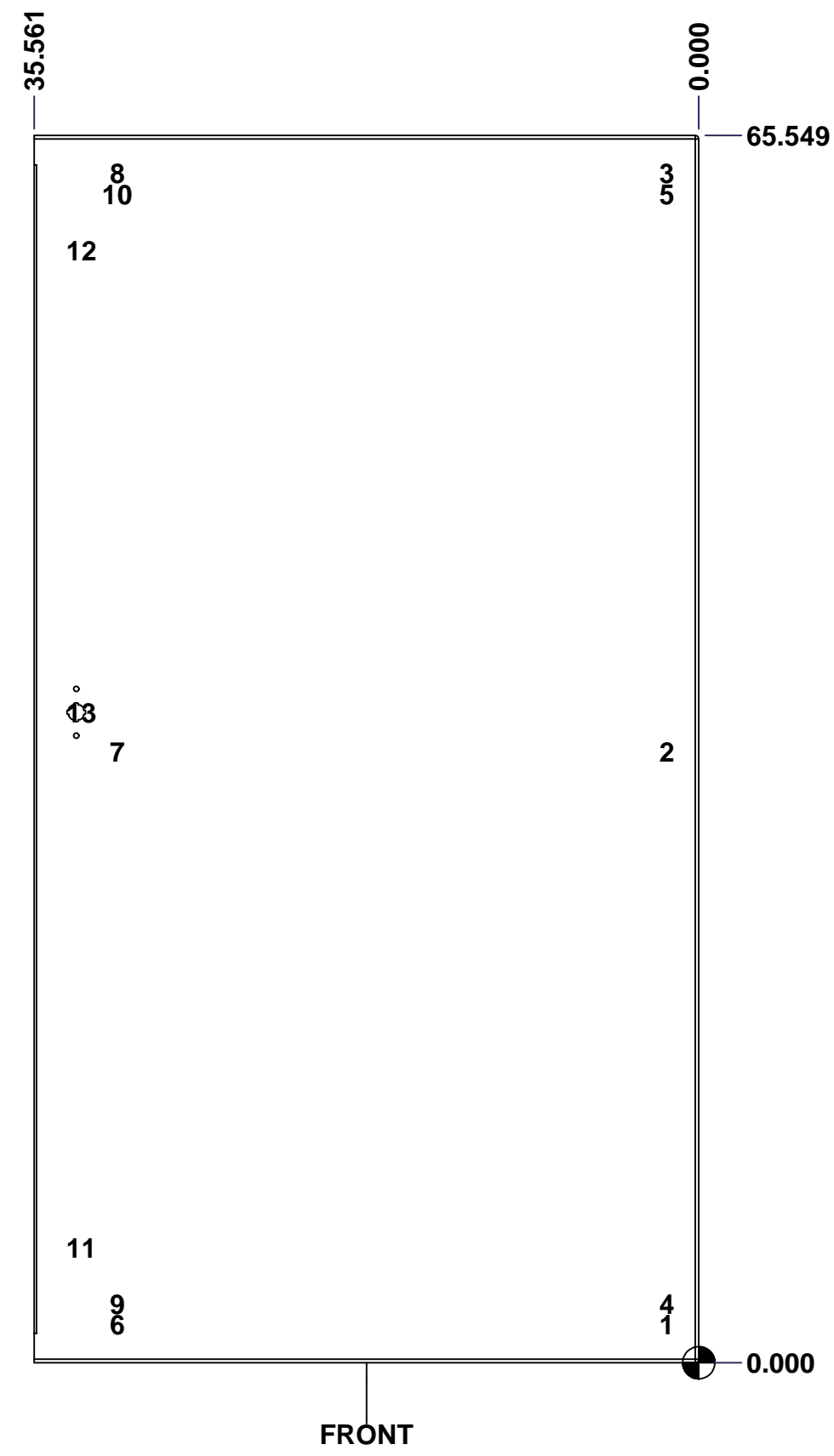

FRONT

	Description	Status
	9500DADD 72" x 72" Back Lock Door	(NULL)
	Part Number Numéro Pièce	Rev.
	9500DADD727224LB	0
		2
		3

This drawing is confidential and must not be reproduced or used without the consent of EXM

Ce dessin est confidentiel et ne doit pas être reproduit ou utilisé sans le consentement de EXM

No.	Revisions	Date	By/Par

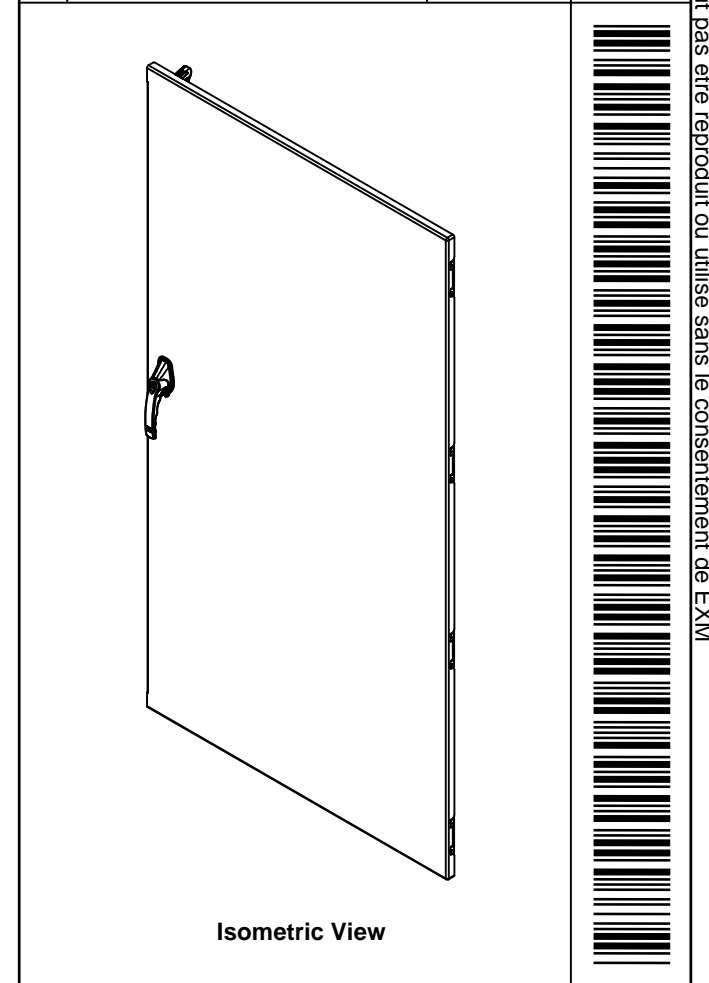

Qty	Part Name	Rev	Description
1	STK-Q-47527	1	9500 Lower Closing Bar 72"
1	STK-Q-47517	1	9500 Upper Closing Bar 72"
1	STK-A-03986-36	2	Gearbox Counterclockwise Assembly (36.0mm)
1	885ESL2A-APHK	6	885 ESL2A-APHK - Zinc Die Cast L-Handle Padlockable Assy
1	STK-P-02400S	0	Powder Paint (Asa-61 Grey / Smooth)
1	9500DADD727224LDG	0	9500DADD 72" x 72" Lock Door Gasket
1	STK-K-10850	3	9500 - Door Stiffener Assembly
2	STK-Q-16410	0	Guide Stud - Largel (No Paint Cap Required)
10	STK-Q-16055	1	M6 x 18mm Stud (No Paint Cap Required)
1	9500DADD727224LB-P	0	9500DADD 72" x 72" Back Lock Door Part
4	STK-K-09860	7	Cabinet Hinge with Captive Pins
2	STK-A-90025	0	9500 - Cabinet Closing Bar End (Large)

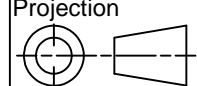
 Tél: (450) 979-4373 Fax: (450) 979-4626 www.exmweb.com		Flatness Aplatissement Max 3.0mm Projection 
Customer Client	Date	Date 28-Oct-14
Drawn By Dessiné Par	BoxCad: BoxCad	
Material Matière	12 Ga Cold Rolled A1008 CS Type B (2.5mm)	
Color Couleur	Asa-61 Grey	Finish Fini Smooth
Description	Detail Rev.	
9500DADD 72" x 72" Back Lock Door		
Part Number Numéro Pièce	Rev.	3
9500DADD727224LB	0	3

Parts List

This drawing is confidential and must not be reproduced or used without the consent of EXM

Ce dessin est confidentiel et ne doit pas être reproduit ou utilisé sans le consentement de EXM



TOP

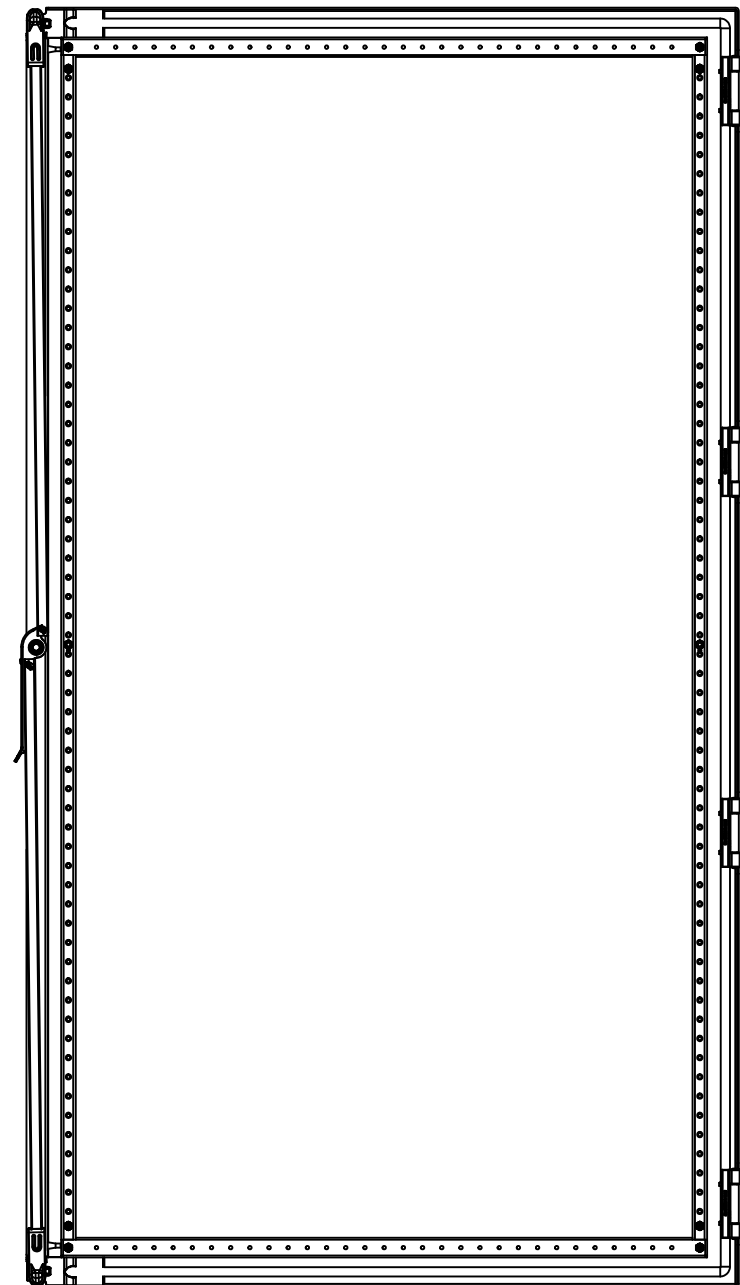

BACK

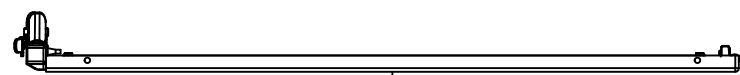

BOTTOM

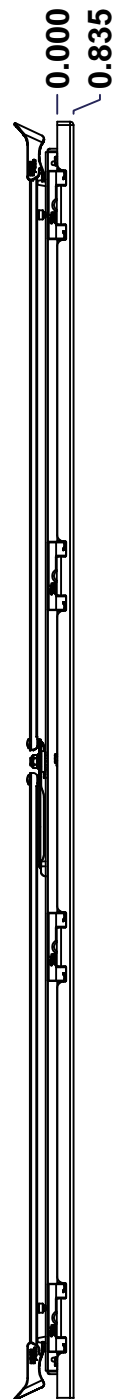

LEFT

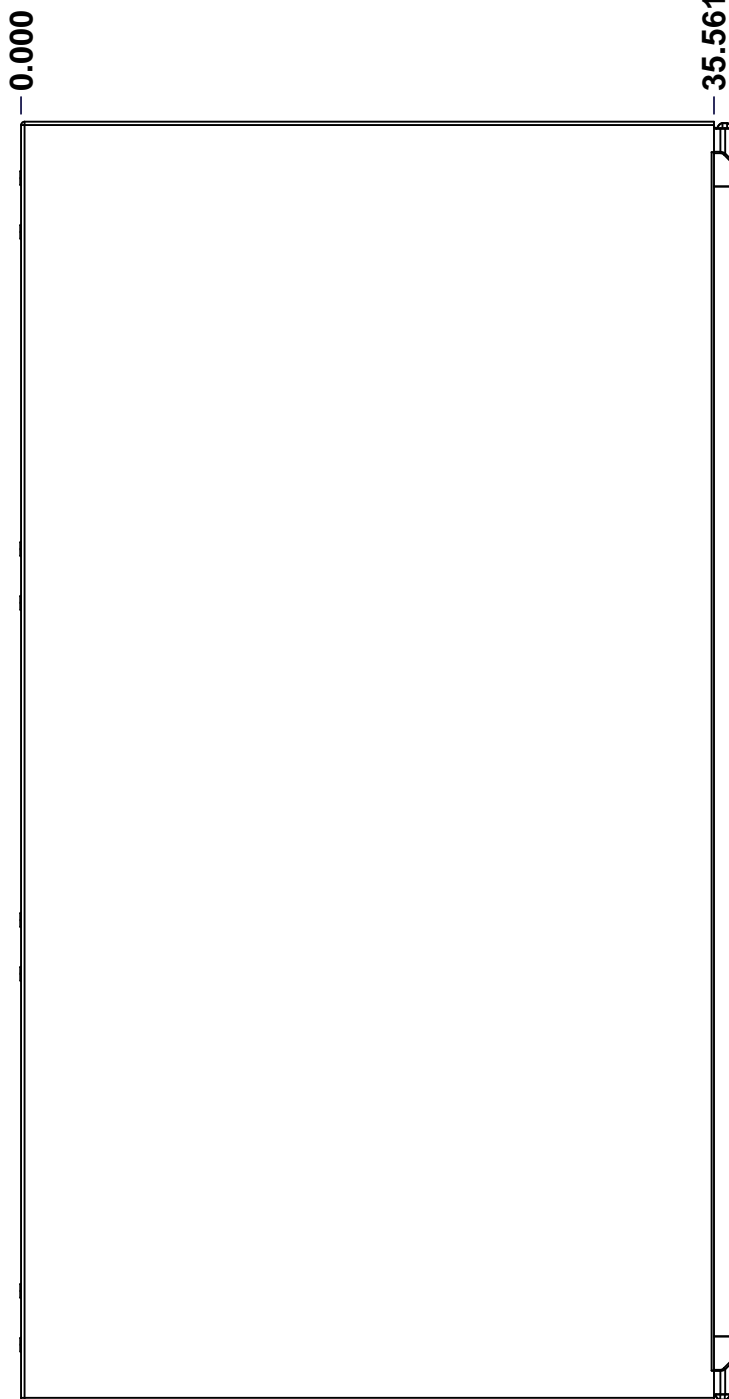

FRONT

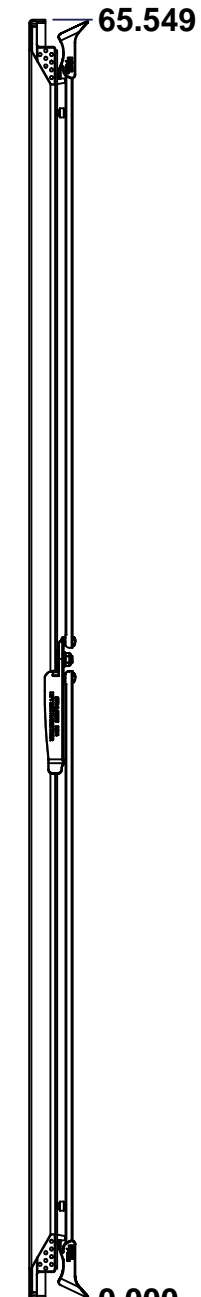

RIGHT

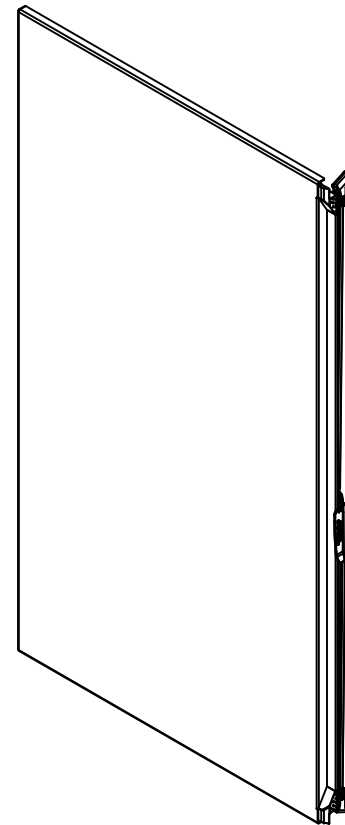

Isometric View

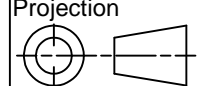

No.	Revisions	Date	By/Par

 Tél: (450) 979-4373 Fax: (450) 979-4626 www.exmweb.com		Flatness Aplatissement Max 3.0mm Projection 
Customer Client	Date	Date
Drawn By Dessiné Par	BoxCad: BoxCad	Date 28-Oct-14
Material Matière	12 Ga Cold Rolled A1008 CS Type B (2.5mm)	
Color Couleur	Asa-61 Grey	Finish Fini Smooth
Description	Detail Rev.	
9500DADD 72" x 72" Back Flange Door		
Part Number Numéro Pièce	Rev. 0	1 / 3

SEE BILL OF MATERIAL ON LAST PAGE

9500DADD727224FB

This drawing is confidential and must not be reproduced or used without the consent of EXM

Ce dessin est confidentiel et ne doit pas être reproduit ou utilisé sans le consentement de EXM

STANDARD FEATURES ARE NOT LISTED IN THIS HOLE TABLE

HOLE TABLE - FRONT VIEW (CUSTOM FEATURE ONLY)

CUT-OUT	XDIM	YDIM	DESCRIPTION
1	2.000	2.028	STUD M6 x 18mm (Inside)
2	2.000	32.628	STUD M6 x 18mm (Inside)
3	2.000	63.521	STUD M6 x 18mm (Inside)
4	2.000	3.139	STUD M6 x 18mm (Inside)
5	2.000	62.409	STUD M6 x 18mm (Inside)
6	34.407	2.028	STUD M6 x 18mm (Inside)
7	34.407	32.628	STUD M6 x 18mm (Inside)
8	34.407	63.521	STUD M6 x 18mm (Inside)
9	34.407	3.139	STUD M6 x 18mm (Inside)
10	34.407	62.409	STUD M6 x 18mm (Inside)
11	36.061	4.774	CLOSING BAR GUIDE (Inside)
12	36.061	60.774	CLOSING BAR GUIDE (Inside)
13	36.061	32.774	STUD M10 x 20mm (Inside)

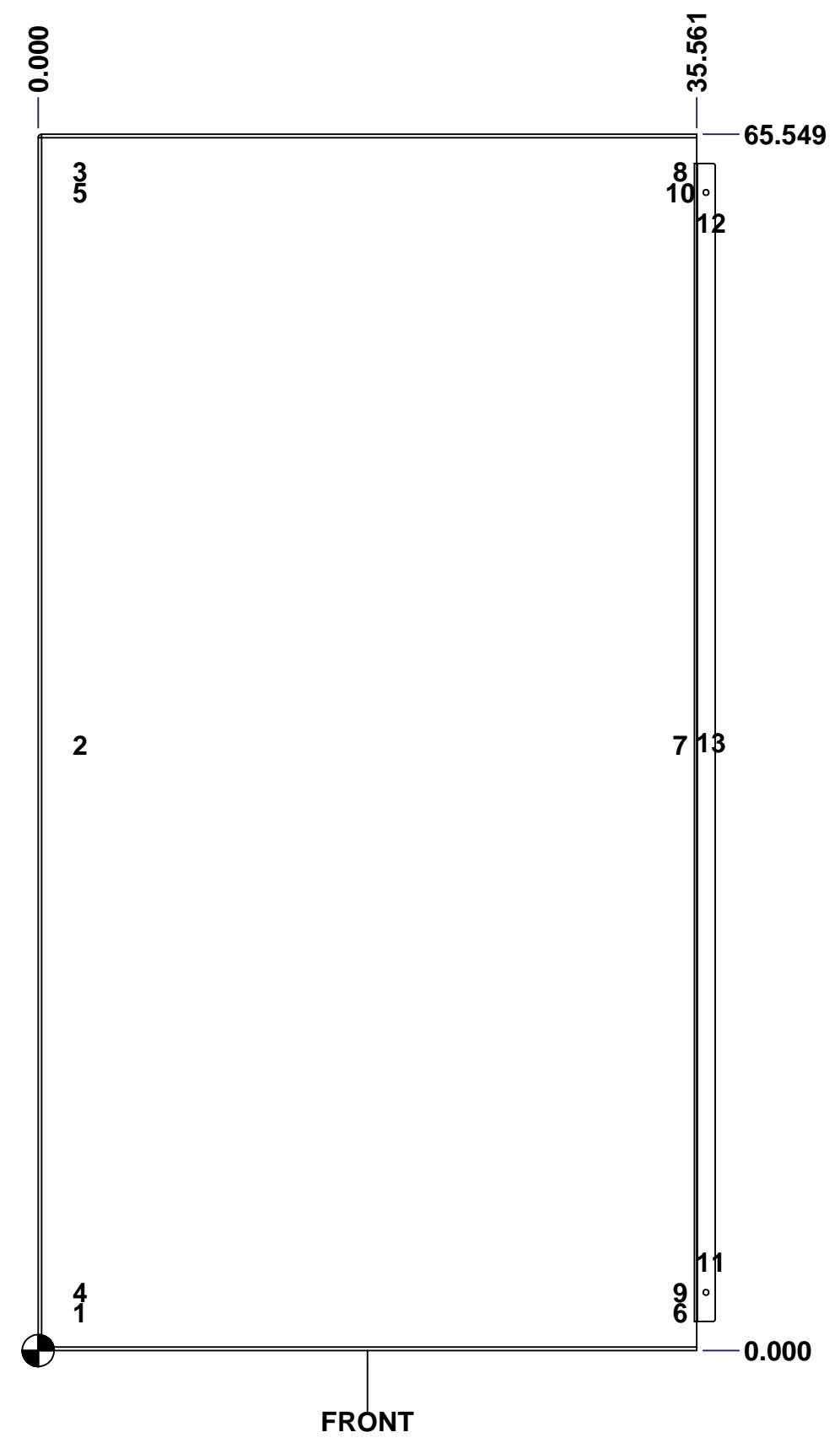

	Description	Status
	9500DADD 72" x 72" Back Flange Door	(NULL)
	Part Number Numéro Pièce	Rev.
	9500DADD727224FB	0 / 2 / 3

This drawing is confidential and must not be reproduced or used without the consent of EXM

Ce dessin est confidentiel et ne doit pas être reproduit ou utilisé sans le consentement de EXM

No.	Revisions	Date	By/Par

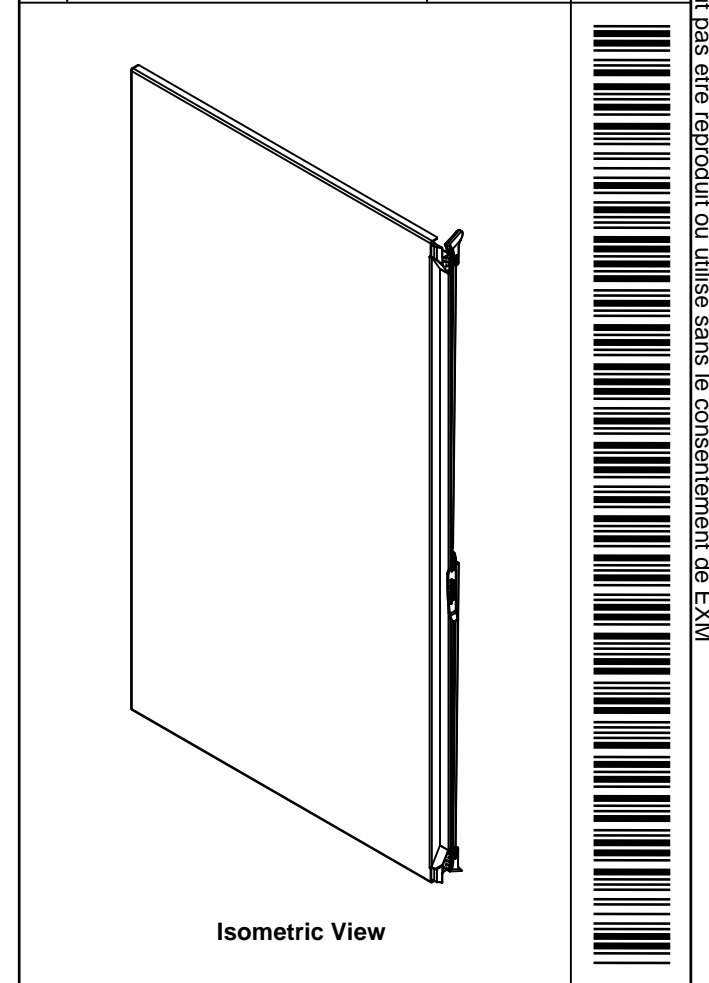

Qty	Part Name	Rev	Description
1	STK-P-02400S	0	Powder Paint (Asa-61 Grey / Smooth)
1	STK-G-03400	0	5500 DD Lower Flange Door Gasket
1	STK-G-03300	0	5500 DD Upper Flange Door Gasket
2	STK-Q-90045	0	Cabinet - Closing Bar End
2	STK-Q-45660-72	2	9500 DD - Flange Door Closing Bar
1	STK-K-50556	4	9500 DD - Flange Door Handle Assy
1	STK-K-20850	3	9500 - Flange Door Stiffener Assembly
1	STK-Q-16122	1	Stud M10 x 20mm
1	STK-G-00701	0	1" x 1/4" Self-Adhesive Neoprene Gasket
1	9500DADD727224FDG	0	9500DADD 72" x 72" Flange Door Gasket
2	STK-Q-16405	6	Guide Stud - Small (No Paint Cap Required)
10	STK-Q-16055	1	M6 x 18mm Stud (No Paint Cap Required)
1	9500DADD727224FB-P	0	9500DADD 72" x 72" Back Flange Door Part
4	STK-K-09860	7	Cabinet Hinge with Captive Pins
Qty	Part Name	Rev	Description
Parts List			

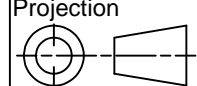
 Tél: (450) 979-4373 Fax: (450) 979-4626 www.exmweb.com	Flatness Aplatissement
	Max 3.0mm
Projection	
Customer Client	Date
Drawn By Dessiné Par	Date 28-Oct-14
Material Matière	12 Ga Cold Rolled A1008 CS Type B (2.5mm)
Color Couleur	Asa-61 Grey
Finish Fini	Smooth
Description	Detail Rev.
9500DADD 72" x 72" Back Flange Door	
Part Number Numéro Pièce	Rev. 3
9500DADD727224FB	0 3

All knockouts are actual size / Les disques défonçables sont grandeur réel
 All dimensions are before paint / Toutes les dimensions sont avant peinture

This drawing is confidential and must not be reproduced or used without the consent of EXM

Ce dessin est confidentiel et ne doit pas être reproduit ou utilisé sans le consentement de EXM

Lifting angles are the flanges of RS and LS top

Struts for light secured with stud only (No weld)

Struts secured with M6 x 10mm studs
 No stud: C_Depth < 12"
 2 studs: 12" ≤ C_Depth < 18"
 3 studs: C_Depth ≥ 18"

Weld inside of struts with the enclosure corner on both ends

Full depth struts length

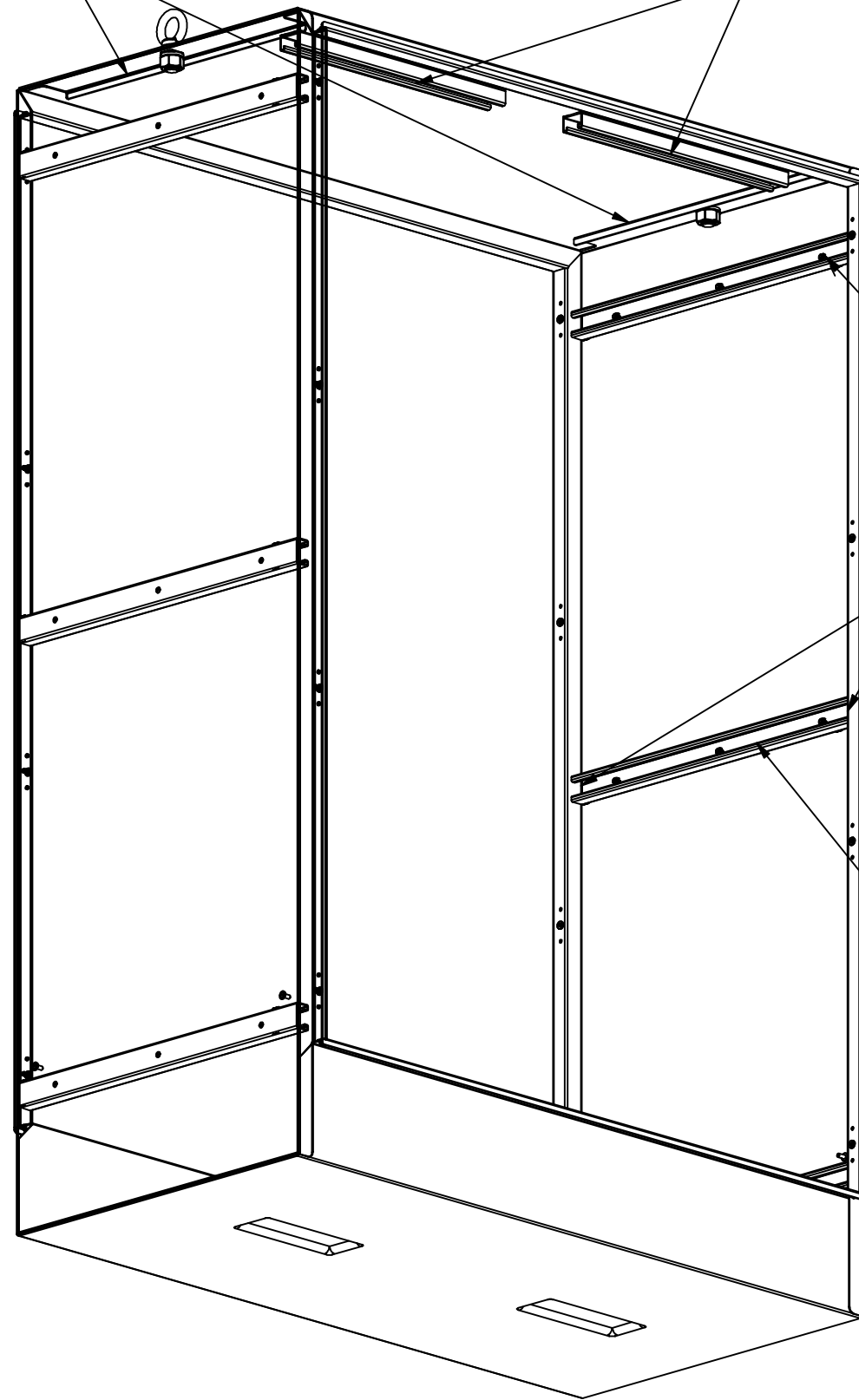

No.	Revisions	Date	By/Par

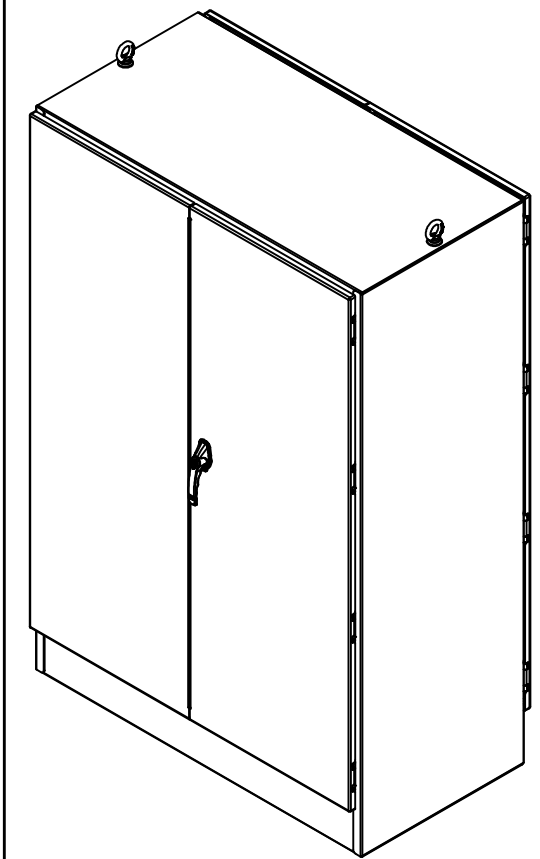

Isometric View



Tél: (450) 979-4373
 Fax: (450) 979-4626
www.exmweb.com

Flatness
Aplatissement

Max 3.0mm

Projection

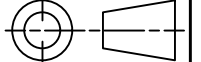

Customer Client	Date
Drawn By / Dessiné Par: PatrickD	Date: 3/9/2020
Material / Matière: N/A	
Color / Couleur: N/A	Finish / Fini: N/A
Description: 9500DADD Welding Detail	Detail Rev.
Part Number / Numéro Pièce: 9500DADD_WELDING_DETAIL	Rev. 0

1
1