

This drawing is confidential and must not be reproduced or used without the consent of EXM

Ce dessin est confidentiel et ne doit pas être reproduit ou utilisé sans le consentement de EXM

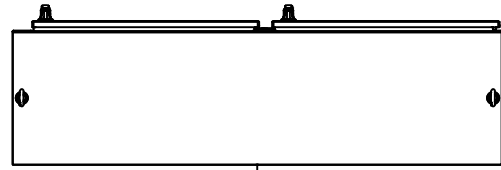

TOP

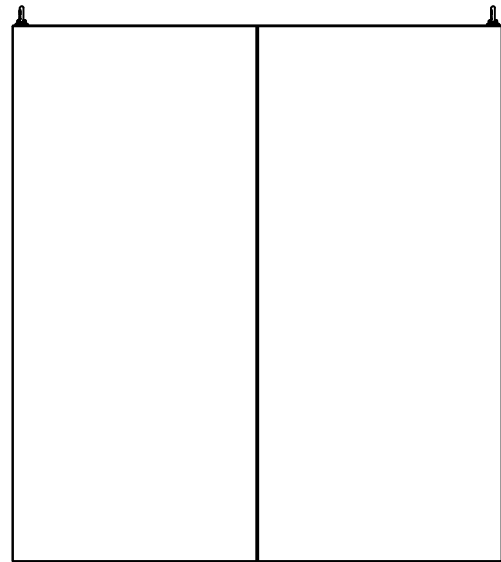

BACK

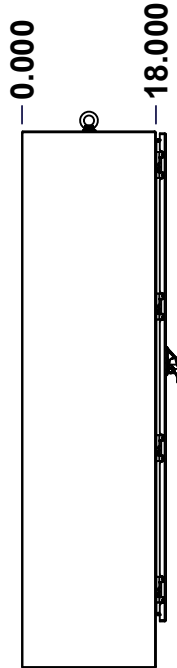

LEFT

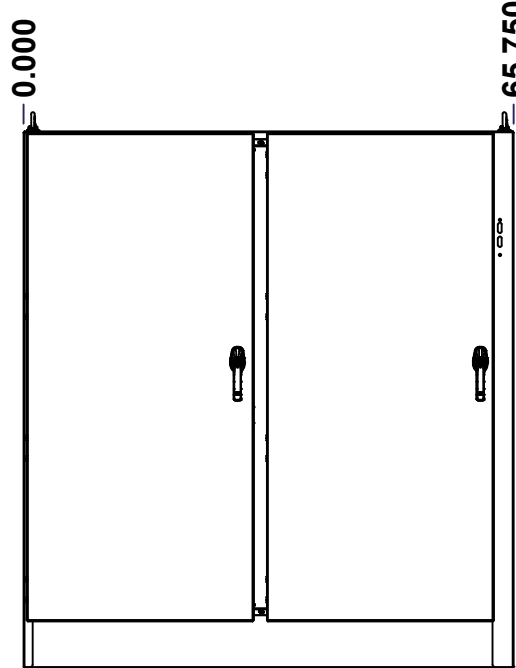

FRONT

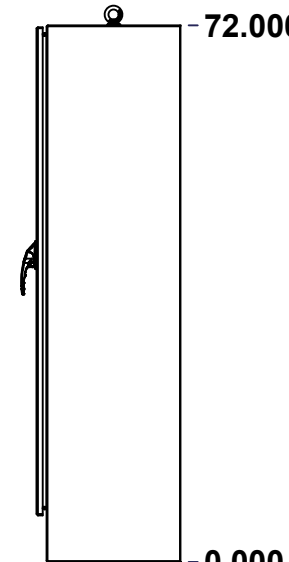

RIGHT

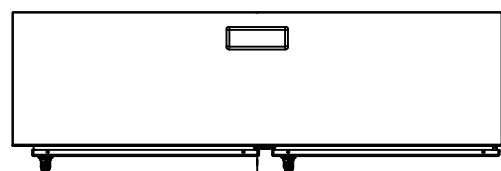

BOTTOM

No.	Revisions	Date	By/Par

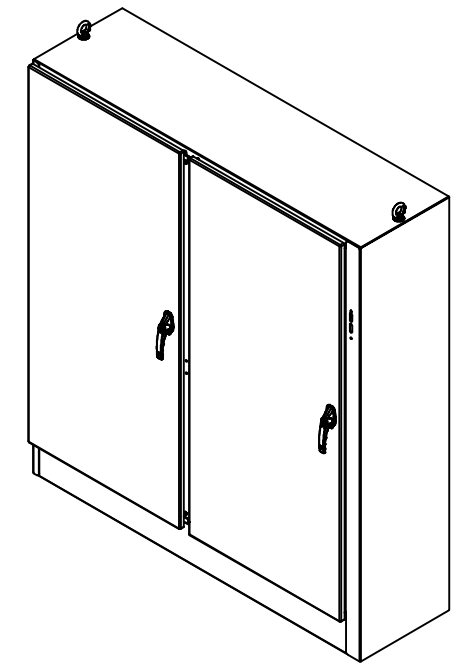

Isometric View



Tél: (450) 979-4373
 Fax: (450) 979-4626
www.exmweb.com

Flatness
Aplatissement
Max 3.0mm
Projection

Customer Client	Date
Drawn By / Dessiné Par: BoxCad: BoxCad	Date: 5/3/2021
Material / Matière: 12 Ga Cold Rolled A1008 CS Type B (2.5mm)	
Color / Couleur: Asa-61 Grey	Finish / Fini: Smooth
Description: 9500U2D 72" x 65.75" x 18" Assembly	Detail Rev.

Part Number / Numéro Pièce: 9500U2D726618	Rev. 1
	0

SEE BILL OF MATERIAL ON LAST PAGE

This drawing is confidential and must not be reproduced or used without the consent of EXM

Ce dessin est confidentiel et ne doit pas être reproduit ou utilisé sans le consentement de EXM

NOTE	
ITEM	DESCRIPTION
1	NEMA 12, 13 Enclosure (IP55)
2	C/W Standard ground studs on box and cover
3	C/W Standard door stiffener
4	C/W Special inner panel (Sold separately)
5	C/W Standard inner panel mounting studs
6	C/W Eyebolts sold separately (Installed by EXM)
7	C/W Struts installed (Included)

No.	Revisions	Date	By/Par

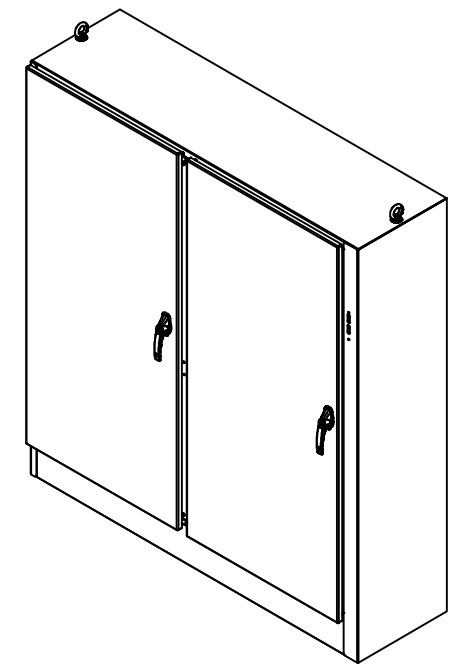

Isometric View

PACKING		
ITEM	QTY	DESCRIPTION
Cardboard sleeve	2	Top and Bottom
Cardboard strip	2	Between back of enclosure and inner panel
Plastic bag	1	To protect cover surface and inside gasket
Cardboard corner	4	To reinforced for the plastic strap tightening
Plastic strap - Black	2	To Squeeze 2 cardboard sleeve together
Packaging label	3	White label with PN
Plastic strap- Green	2	To secure the enclosure to the wood pallet
Wood Pallet	1	2" deeper and 3" larger than enclosure size

1	880INTI	4	880 INTI - Interlock Post Kit
1	9500U2D726618GP	0	9500U2D Gland Plate
1	880EB14	2	Eye Bolt M14 (Pack of 2)
10	STK-Q-07320	0	Flange Lock Nut M10
1	9500U2D726618IP	0	9500U2D 72" x 65.75" Inner Panel
10	STK-Q-07620	0	M10 Plastic Spacer 0.875"
1	9500U2D726618FD	0	9500U2D 72" x 65.75" Lock Door
1	9500U2D726618LD	0	9500U2D 72" x 65.75" Lock Door
1	9500U2D726618B	0	9500U2D 72" x 65.75" x 18" Body
8	STK-Q-04050-10	8	M6 x 10mm Hexagon Socket Head Machine Screw with Nyseal
Qty	Part Number	Rev	Description
Parts List			

	Tél: (450) 979-4373 Fax: (450) 979-4626 www.exmweb.com	Flatness Aplatissement	Max 3.0mm
		Projection	
Customer Client		Date	
Drawn By Dessiné Par	BoxCad: BoxCad	Date	5/3/2021
Material Matière	12 Ga Cold Rolled A1008 CS Type B (2.5mm)		
Color Couleur	Asa-61 Grey	Finish Fini	Smooth
Description	9500U2D 72" x 65.75" x 18" Assembly		Detail Rev.
Part Number Numéro Pièce	9500U2D726618		Rev. 2
			0 17

This drawing is confidential and must not be reproduced or used without the consent of EXM

Ce dessin est confidentiel et ne doit pas être reproduit ou utilisé sans le consentement de EXM

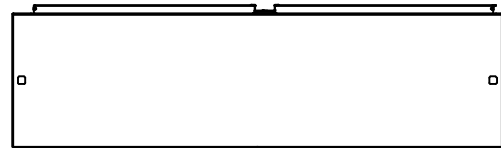

TOP

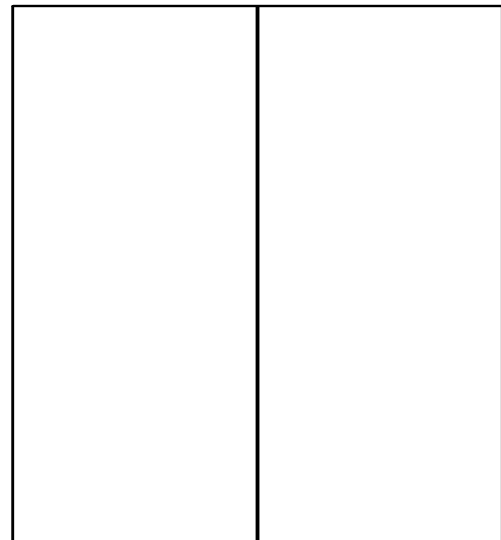

BACK

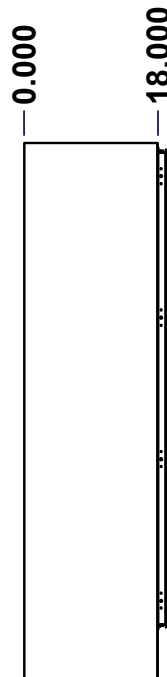

LEFT

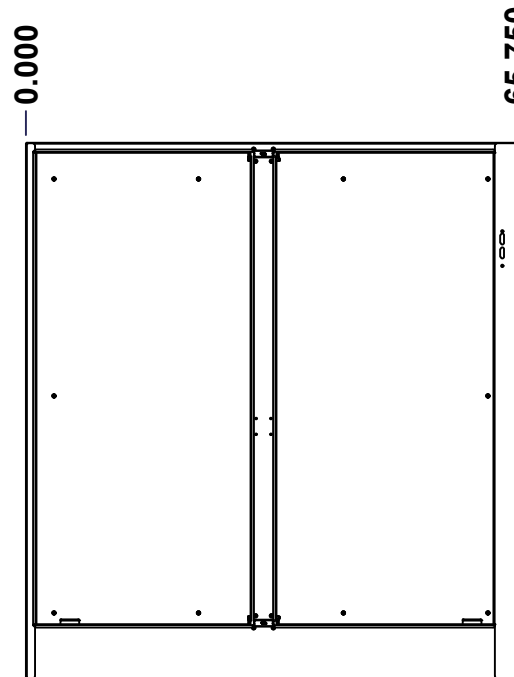

FRONT

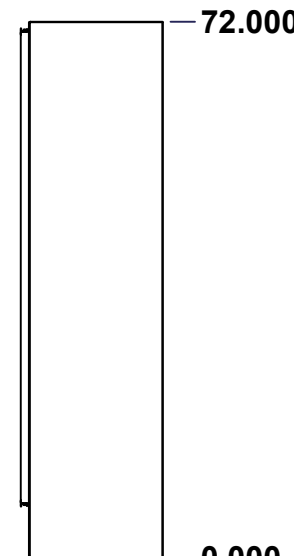

RIGHT

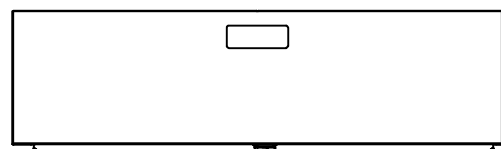

BOTTOM

No.	Revisions	Date	By/Par

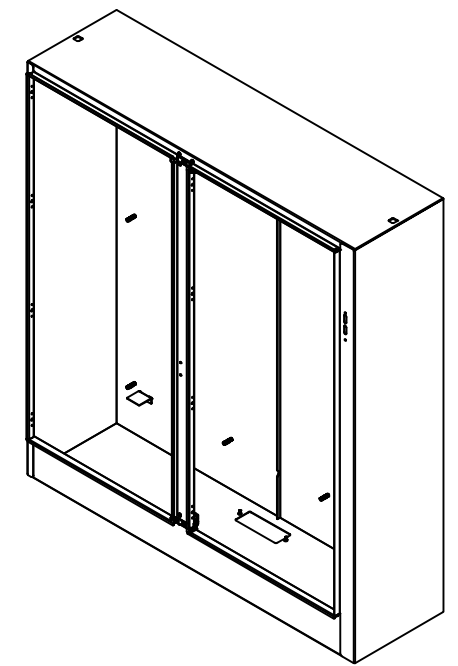

Isometric View



Tél: (450) 979-4373
 Fax: (450) 979-4626
www.exmweb.com

Flatness
 Aplatissement
 Max 3.0mm
 Projection

Customer Client	Date
Drawn By Dessiné Par BoxCad: BoxCad	Date 5/3/2021
Material Matière 12 Ga Cold Rolled A1008 CS Type B (2.5mm)	
Color Couleur Asa-61 Grey	Finish Fini Smooth
Description 9500U2D 72" x 65.75" x 18" Body	Detail Rev.

Part Number Numéro Pièce	Rev.	3
9500U2D726618B	0	17

SEE BILL OF MATERIAL ON LAST PAGE

This drawing is confidential and must not be reproduced or used without the consent of EXM

Ce dessin est confidentiel et ne doit pas être reproduit ou utilisé sans le consentement de EXM

STANDARD FEATURES ARE NOT LISTED IN THIS HOLE TABLE

HOLE TABLE - TOP VIEW (CUSTOM FEATURE ONLY)

CUT-OUT	XDIM	YDIM	DESCRIPTION
1	16.349	13.911	Struts CR400 27.500" (Inside)
2	49.224	13.911	Struts CR400 27.500" (Inside)
3	16.349	14.840	STUDS M6 x 10mm (Inside)
4	30.215	13.911	STUDS M6 x 10mm (Inside)
5	49.224	14.840	STUDS M6 x 10mm (Inside)
6	63.090	13.911	STUDS M6 x 10mm (Inside)

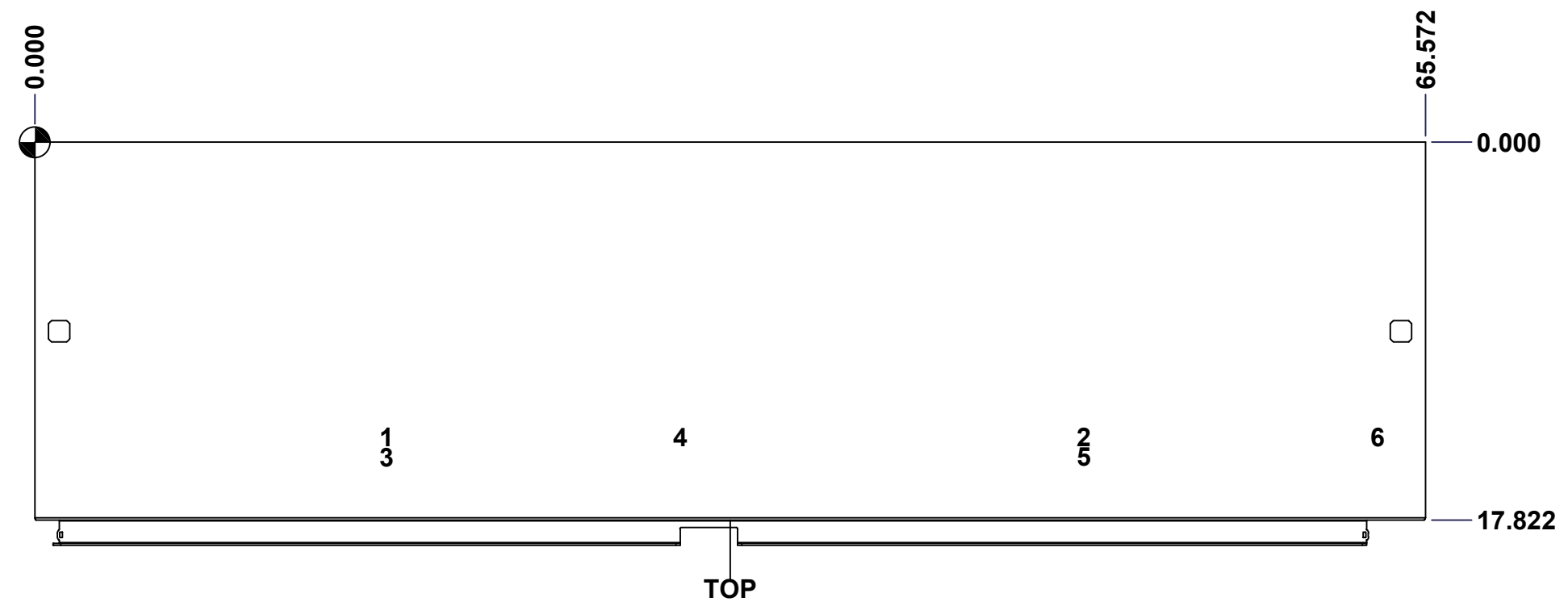

	Description 9500U2D 72" x 65.75" x 18" Body	Status (NULL)
	Part Number Numéro Pièce 9500U2D726618B	Rev. 4 0

This drawing is confidential and must not be reproduced or used without the consent of EXM

Ce dessin est confidentiel et ne doit pas être reproduit ou utilisé sans le consentement de EXM

STANDARD FEATURES ARE NOT LISTED IN THIS HOLE TABLE			
HOLE TABLE - BOTTOM VIEW (CUSTOM FEATURE ONLY)			
CUT-OUT	XDIM	YDIM	DESCRIPTION
1	28.161	3.411	GP STUD M6 x 16mm (Inside)
2	37.411	3.411	GP STUD M6 x 16mm (Inside)

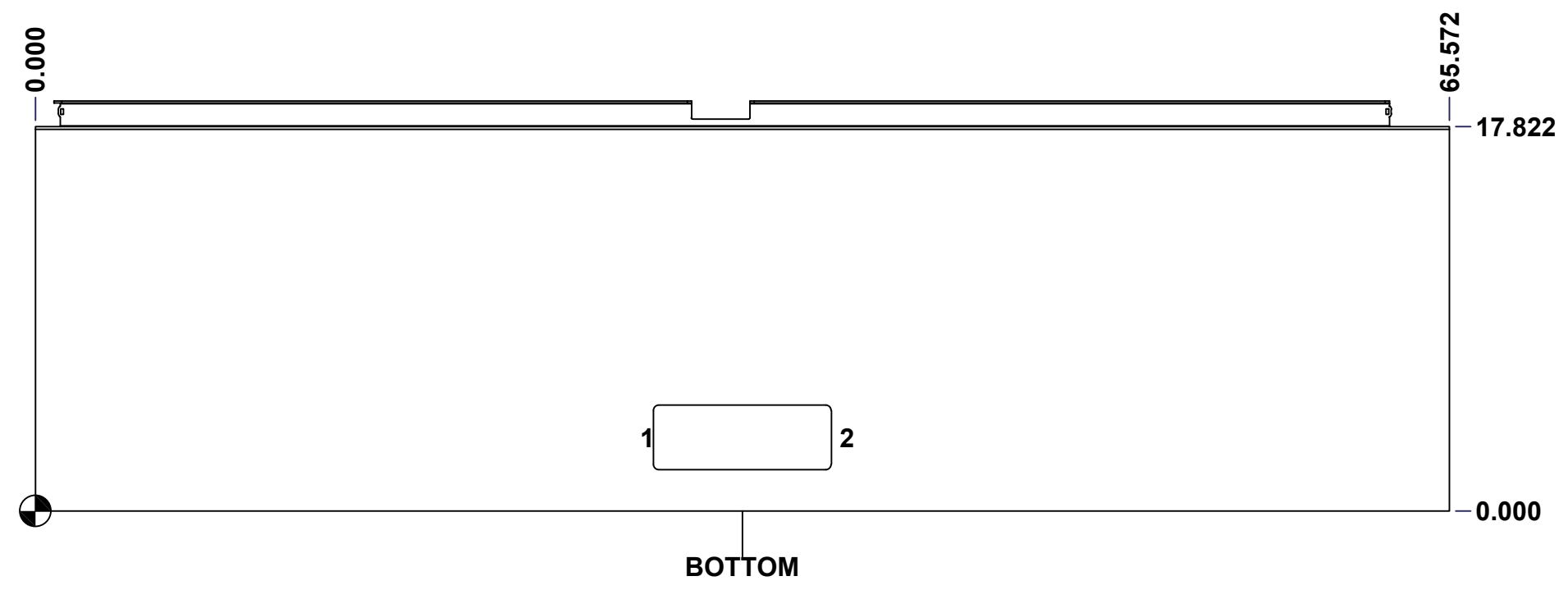

	Description	Status
	9500U2D 72" x 65.75" x 18" Body	(NULL)
Part Number Numéro Pièce	9500U2D726618B	Rev. 5
		0
		17

This drawing is confidential and must not be reproduced or used without the consent of EXM

Ce dessin est confidentiel et ne doit pas être reproduit ou utilisé sans le consentement de EXM

STANDARD FEATURES ARE NOT LISTED IN THIS HOLE TABLE			
HOLE TABLE - LEFT VIEW (CUSTOM FEATURE ONLY)			
CUT-OUT	XDIM	YDIM	DESCRIPTION
1	16.411	1.911	GND STUD M6 x 16mm (Inside)

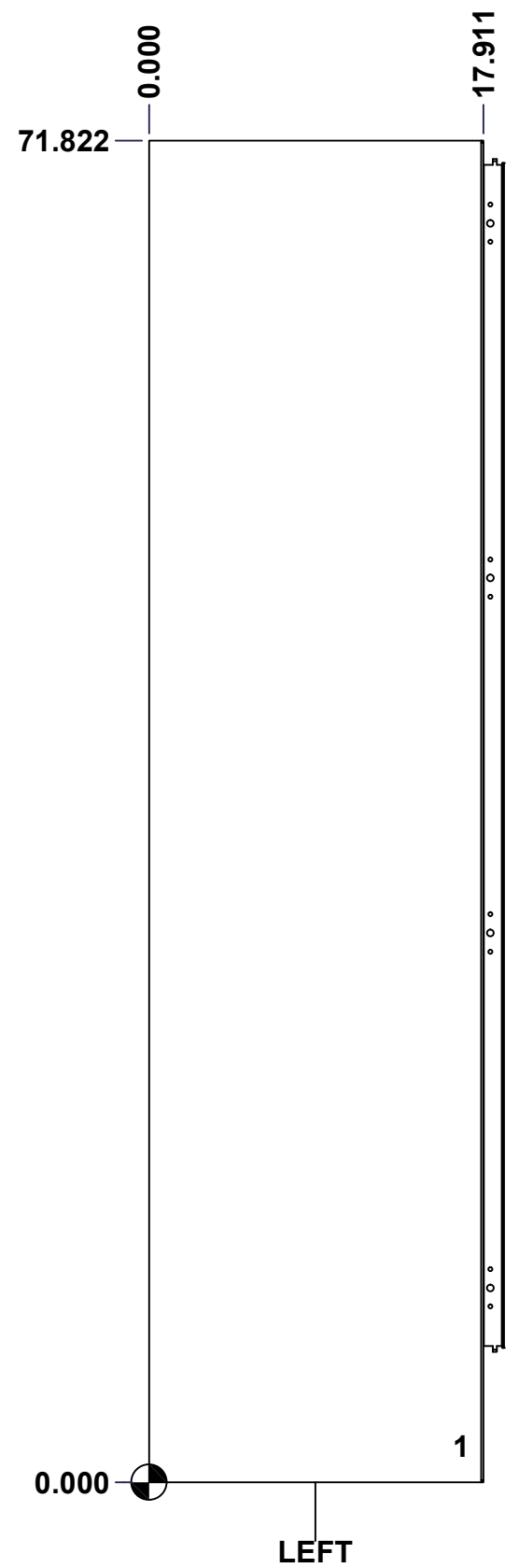

	Description	Status	
	9500U2D 72" x 65.75" x 18" Body	(NULL)	
	Part Number Numéro Pièce	Rev.	6
	9500U2D726618B	0	17

This drawing is confidential and must not be reproduced or used without the consent of EXM

Ce dessin est confidentiel et ne doit pas être reproduit ou utilisé sans le consentement de EXM

STANDARD FEATURES ARE NOT LISTED IN THIS HOLE TABLE

HOLE TABLE - BACK VIEW (CUSTOM FEATURE ONLY)

CUT-OUT	XDIM	YDIM	DESCRIPTION
1	3.750	8.875	IP STUD M10 x 40mm (Inside)
2	62.000	8.875	IP STUD M10 x 40mm (Inside)
3	3.750	38.000	IP STUD M10 x 40mm (Inside)
4	62.000	38.000	IP STUD M10 x 40mm (Inside)
5	3.750	67.125	IP STUD M10 x 40mm (Inside)
6	62.000	67.125	IP STUD M10 x 40mm (Inside)
7	23.167	8.875	IP STUD M10 x 40mm (Inside)
8	42.583	8.875	IP STUD M10 x 40mm (Inside)
9	23.167	67.125	IP STUD M10 x 40mm (Inside)
10	42.583	67.125	IP STUD M10 x 40mm (Inside)
-----	-----	-----	-----
11	5.875	7.500	IP SUPPORT ANGLE (Inside)
12	59.875	7.500	IP SUPPORT ANGLE (Inside)

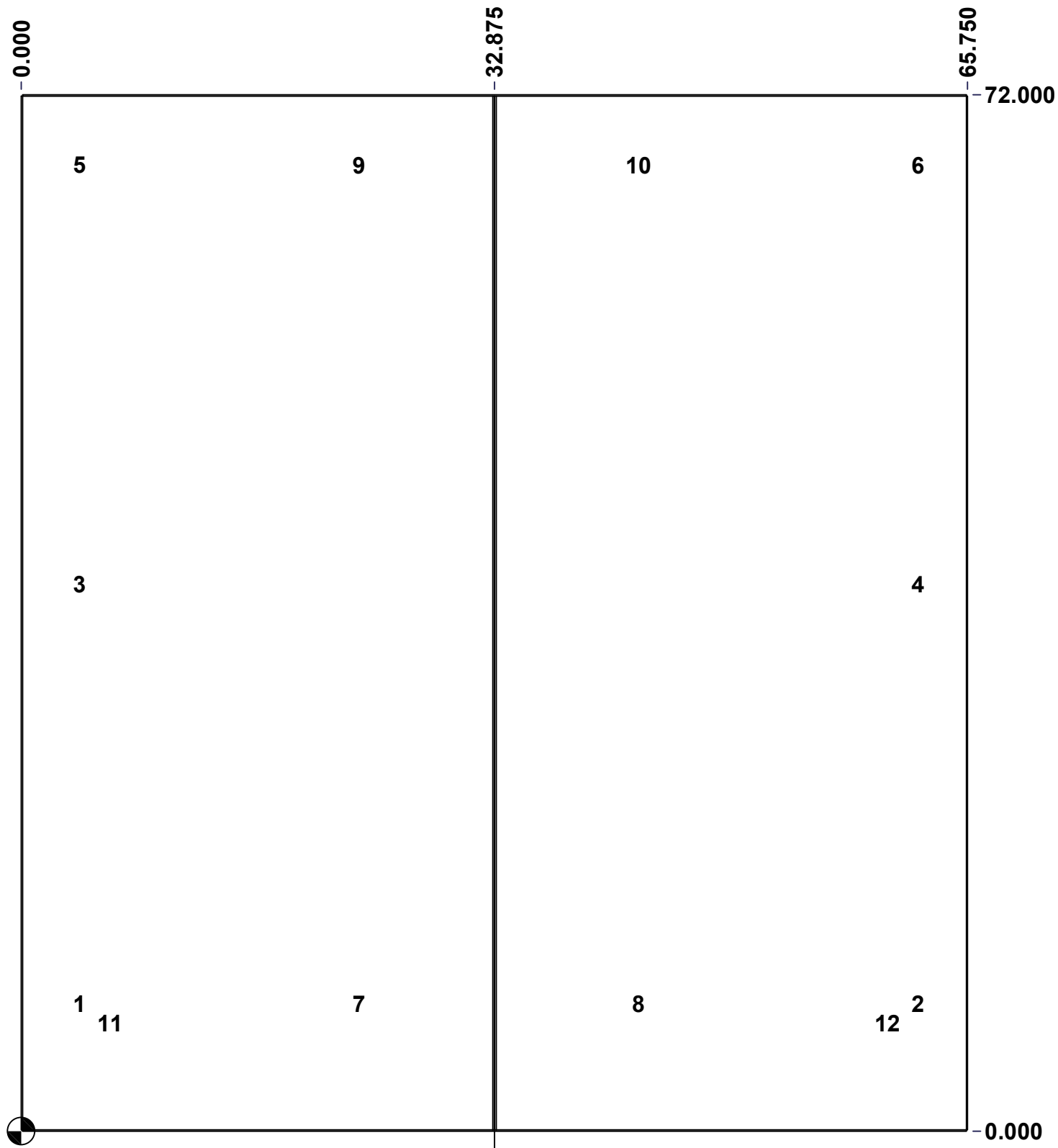

BACK

	Description	Status
	9500U2D 72" x 65.75" x 18" Body	(NULL)
	Part Number	Rev.
	Numéro Pièce	7
	9500U2D726618B	0
		17

This drawing is confidential and must not be reproduced or used without the consent of EXM

Ce dessin est confidentiel et ne doit pas être reproduit ou utilisé sans le consentement de EXM

STANDARD FEATURES ARE NOT LISTED IN THIS HOLE TABLE

HOLE TABLE - CENTER VIEW (CUSTOM FEATURE ONLY)

CUT-OUT	XDIM	YDIM	DESCRIPTION
1	1.732	3.648	GND STUD M6 x 16mm (Inside)

2	0.748	25.138	PEM FH-M6-15ZI (Inside)
3	0.748	27.264	PEM FH-M6-15ZI (Inside)
4	2.717	25.138	PEM FH-M6-15ZI (Inside)
5	2.717	27.264	PEM FH-M6-15ZI (Inside)

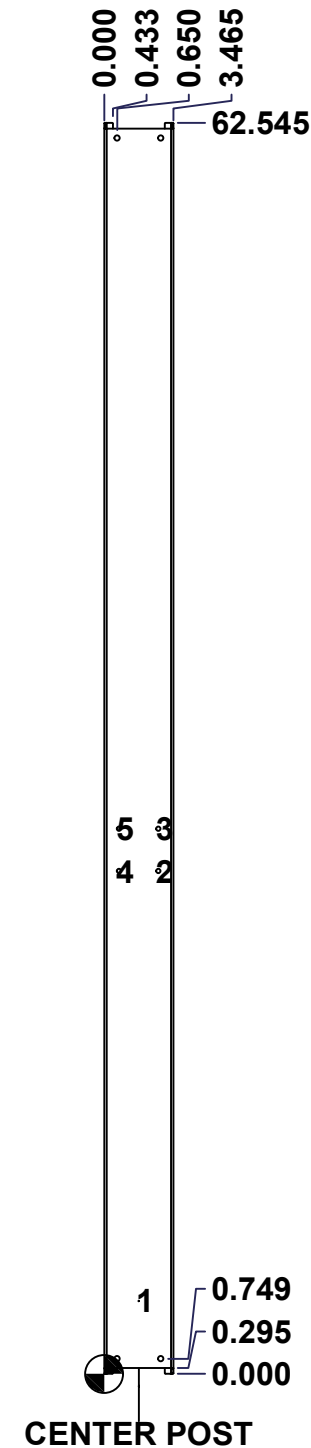

	Description	Status
	9500U2D 72" x 65.75" x 18" Body	(NULL)
	Part Number	Rev.
	Numéro Pièce	8
	9500U2D726618B	0
		17

This drawing is confidential and must not be reproduced or used without the consent of EXM

Ce dessin est confidentiel et ne doit pas être reproduit ou utilisé sans le consentement de EXM

No.	Revisions	Date	By/Par

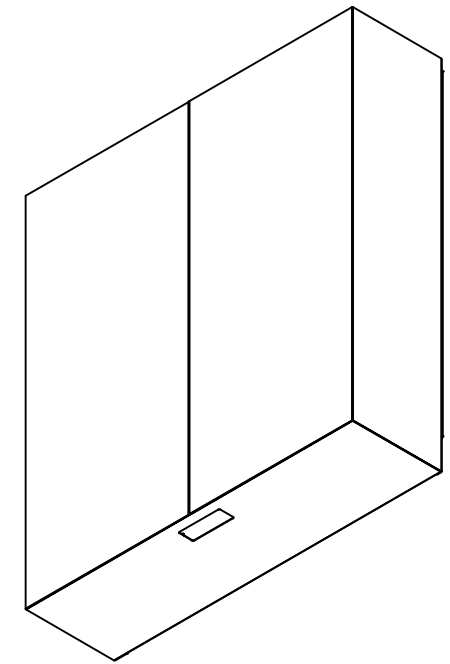

Isometric View



4	STK-Q-16030	0	Stud M6 x 10mm Steel
4	STK-PEM-FH-M6-15ZI	0	PEM Self-Clinching Stud M6 x 15.0mm
2	9500U2D726618BPA-P	0	9500U2D Inner Panel Support Angle
2	STK-Q-74900	0	Eyebolt Lifting Angle (8.750")
1	STK-P-02400S	0	Powder Paint (Asa-61 Grey / Smooth)
1	STK-A-75454	3	Center Post - Sealing Block with Latch Assembly (Large)
1	9500U2D726618CP-P	0	9500U2D 72" Center Post Part
10	STK-Q-16100	0	Stud M10 x 40mm Steel
1	9500U2D726618BT-P	0	9500U2D 65.75" x 18" Bottom Part
1	9500U2D726618T-P	0	9500U2D 65.75" x 18" Top Part
1	9500U2D726618RS-P	0	9500U2D 72" x 65.75" Right Part
1	9500U2D726618LS-P	0	9500U2D 72" x 65.75" Left Part
1	9500U2D726618BR-P	0	9500U2D 72" x 65.75" Back Right Part
1	9500U2D726618BL-P	0	9500U2D 72" x 65.75" Back Left Part
2	9500U2D726618_CR400 MS_27.5	0	Commercial Roll Mild Steel (27.5in long)
4	STK-Q-16080	0	Ground Stud M6 x 16mm Steel

Qty	Part Number	Rev	Description
Parts List			

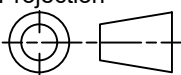
 Tél: (450) 979-4373 Fax: (450) 979-4626 www.exmweb.com	Flatness Aplatissement	Max 3.0mm
	Projection	
Customer Client	Date	
Drawn By Dessiné Par	BoxCad: BoxCad	Date 5/3/2021
Material Matière	12 Ga Cold Rolled A1008 CS Type B (2.5mm)	
Color Couleur	Asa-61 Grey	Finish Fini Smooth
Description	Detail Rev.	
9500U2D 72" x 65.75" x 18" Body		
Part Number Numéro Pièce	Rev.	9
9500U2D726618B	0	17

This drawing is confidential and must not be reproduced or used without the consent of EXM

Ce dessin est confidentiel et ne doit pas être reproduit ou utilisé sans le consentement de EXM

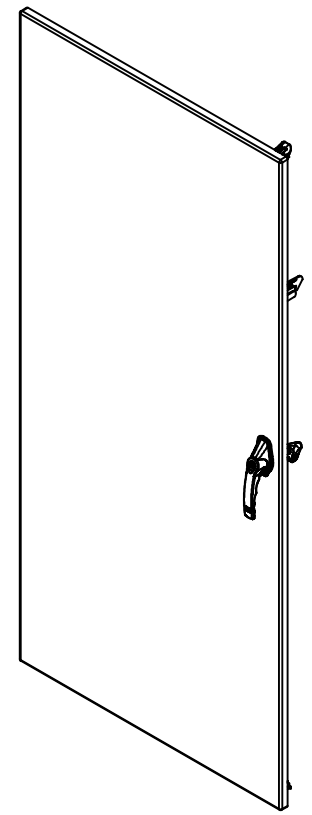
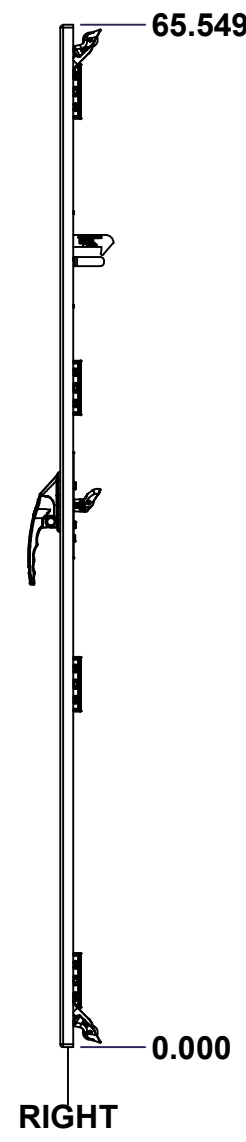
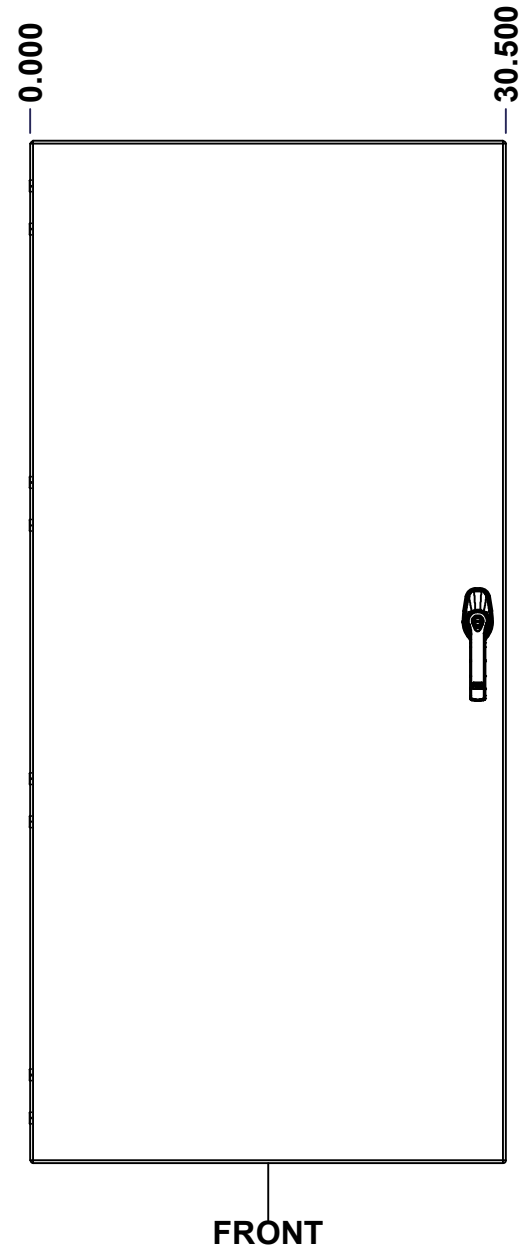
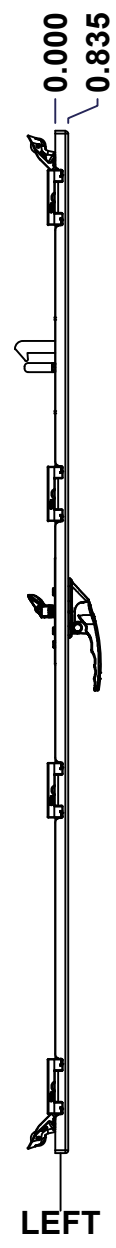
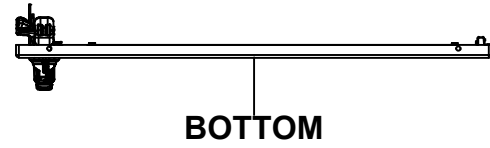
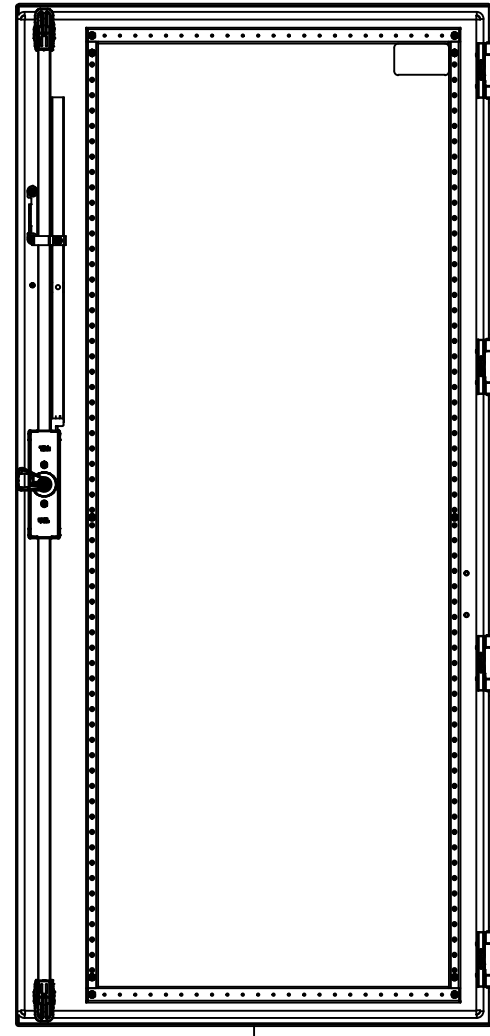
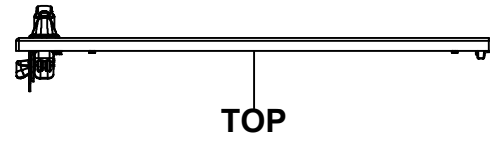

No.	Revisions	Date	By/Par

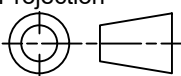
 Tél: (450) 979-4373 Fax: (450) 979-4626 www.exmweb.com		Flatness Aplatissement Max 3.0mm Projection 
Customer Client		Date
Drawn By Dessiné Par	BoxCad: BoxCad	Date 5/3/2021
Material Matière	12 Ga Cold Rolled A1008 CS Type B (2.5mm)	
Color Couleur	Asa-61 Grey	Finish Fini Smooth
Description	9500U2D 72" x 65.75" Lock Door	
Part Number Numéro Pièce	9500U2D726618LD	Detail Rev.
	Rev. 0	10 / 17

SEE BILL OF MATERIAL ON LAST PAGE

This drawing is confidential and must not be reproduced or used without the consent of EXM

Ce dessin est confidentiel et ne doit pas être reproduit ou utilisé sans le consentement de EXM

STANDARD FEATURES ARE NOT LISTED IN THIS HOLE TABLE

HOLE TABLE - FRONT VIEW (CUSTOM FEATURE ONLY)

CUT-OUT	XDIM	YDIM	DESCRIPTION
1	2.375	2.028	STUD M6 x 18mm (Inside)
2	2.375	32.628	STUD M6 x 18mm (Inside)
3	2.375	63.521	STUD M6 x 18mm (Inside)
4	2.375	3.139	STUD M6 x 18mm (Inside)
5	2.375	62.409	STUD M6 x 18mm (Inside)
6	25.251	2.028	STUD M6 x 18mm (Inside)
7	25.251	32.628	STUD M6 x 18mm (Inside)
8	25.251	63.521	STUD M6 x 18mm (Inside)
9	25.251	3.139	STUD M6 x 18mm (Inside)
10	25.251	62.409	STUD M6 x 18mm (Inside)
11	29.455	53.511	STUD M6 x 18mm (Inside)
12	29.455	50.511	STUD M6 x 18mm (Inside)
13	29.455	47.511	STUD M6 x 18mm (Inside)
14	28.678	6.179	LARGE CBAR GUIDE (Inside)
15	28.678	59.370	LARGE CBAR GUIDE (Inside)
16	27.822	57.870	LARGE CBAR GUIDE (Inside)
-----	-----	-----	-----
17	28.688	34.743	HANDLE 885 ESL2A-APHD @ 0.0°
18	1.610	26.363	STUDS M6 x 18mm (Inside)
19	1.610	29.041	STUDS M6 x 18mm (Inside)

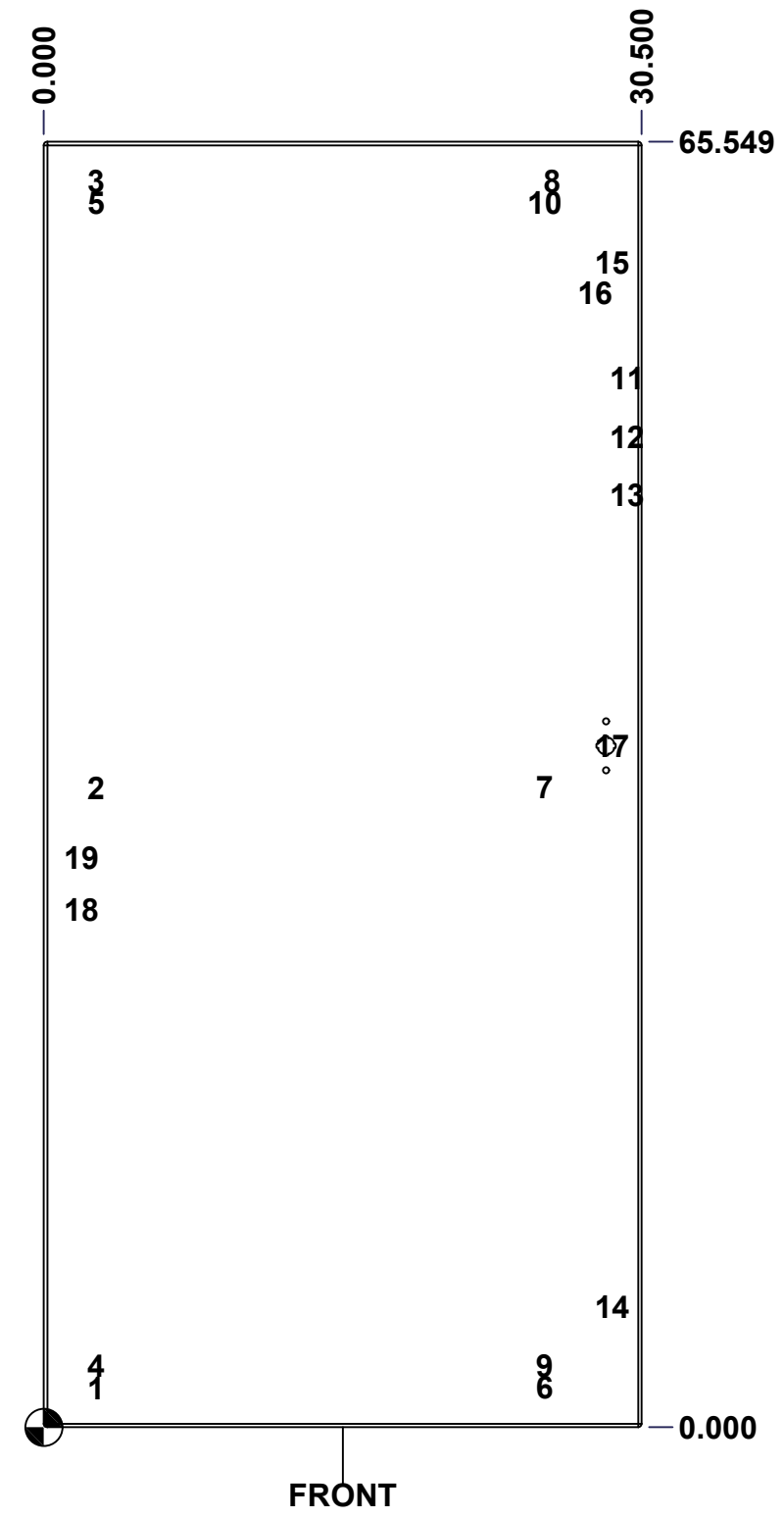

	Description	Status	
	9500U2D 72" x 65.75" Lock Door	(NULL)	
	Part Number Numéro Pièce	Rev.	11
	9500U2D726618LD	0	17

This drawing is confidential and must not be reproduced or used without the consent of EXM

Ce dessin est confidentiel et ne doit pas être reproduit ou utilisé sans le consentement de EXM

No.	Revisions	Date	By/Par

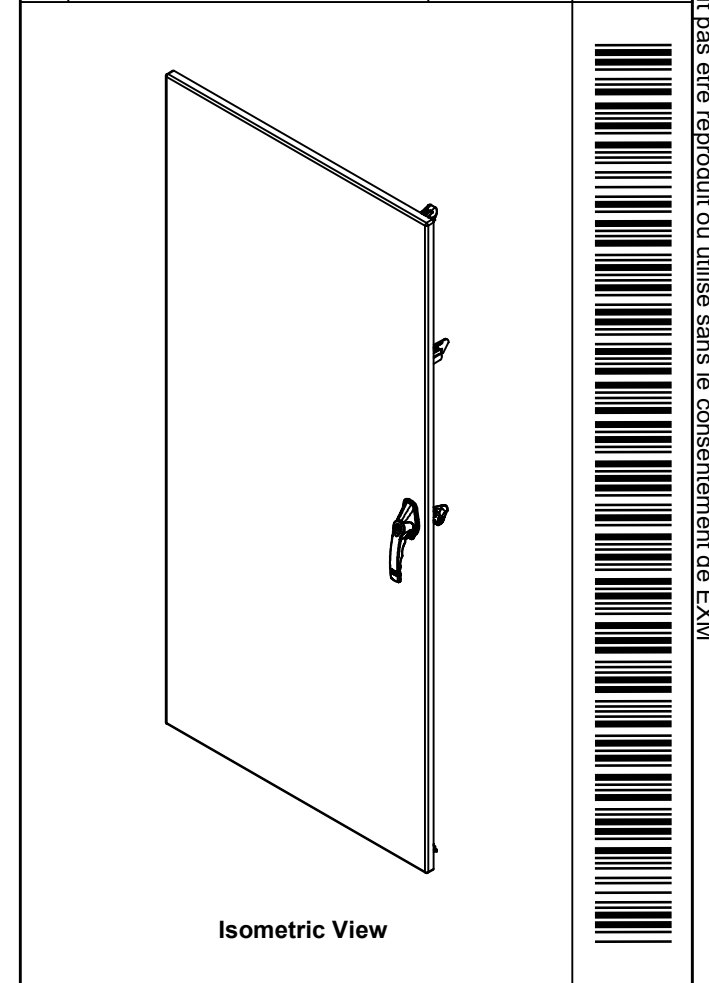

EXM
www.exmweb.com

Tél: (450) 979-4373
Fax: (450) 979-4626

Flatness
Aplatissement
Max 3.0mm

Projection

1	STK-K-09572	0	9500 UxD 72" Locking Mechanism Kit
2	STK-Q-16050	1	Stud M6 x 18mm Steel
1	885ESL2A-APHD	1	885 ESL2A-APHD - Zinc Die Cast L-Handle Padlockable Assy - Slot Cylinder
1	STK-P-02400S	0	Powder Paint (Asa-61 Grey / Smooth)
1	STK-S-00100	0	3.5" x 2" Silver Milar Flexcon Sticker
1	9500U2D726618DS1	0	9500U2D 72" x 65.75" Door Stiffener
3	STK-Q-16410	0	Guide Stud - Largel (No Paint Cap Required)
13	STK-Q-16055	1	M6 x 18mm Stud (No Paint Cap Required)
1	9500U2D726618LDG	0	9500U2D 72" x 65.75" Lock Door Gasket
1	9500U2D726618LD-P	0	9500U2D 72" x 65.75" Lock Door Part
4	STK-K-09860	7	Cabinet Hinge with Captive Pins
QTY	Part Number	Rev	Description
Parts List			

Customer Client	Date
Drawn By Dessiné Par BoxCad: BoxCad	Date 5/3/2021
Material Matière 12 Ga Cold Rolled A1008 CS Type B (2.5mm)	
Color Couleur Asa-61 Grey	Finish Fini Smooth
Description 9500U2D 72" x 65.75" Lock Door	Detail Rev.
Part Number Numéro Pièce 9500U2D726618LD	Rev. 0
	12 17

This drawing is confidential and must not be reproduced or used without the consent of EXM

Ce dessin est confidentiel et ne doit pas être reproduit ou utilisé sans le consentement de EXM

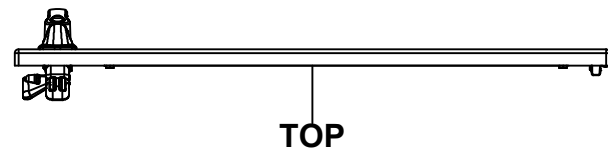

TOP

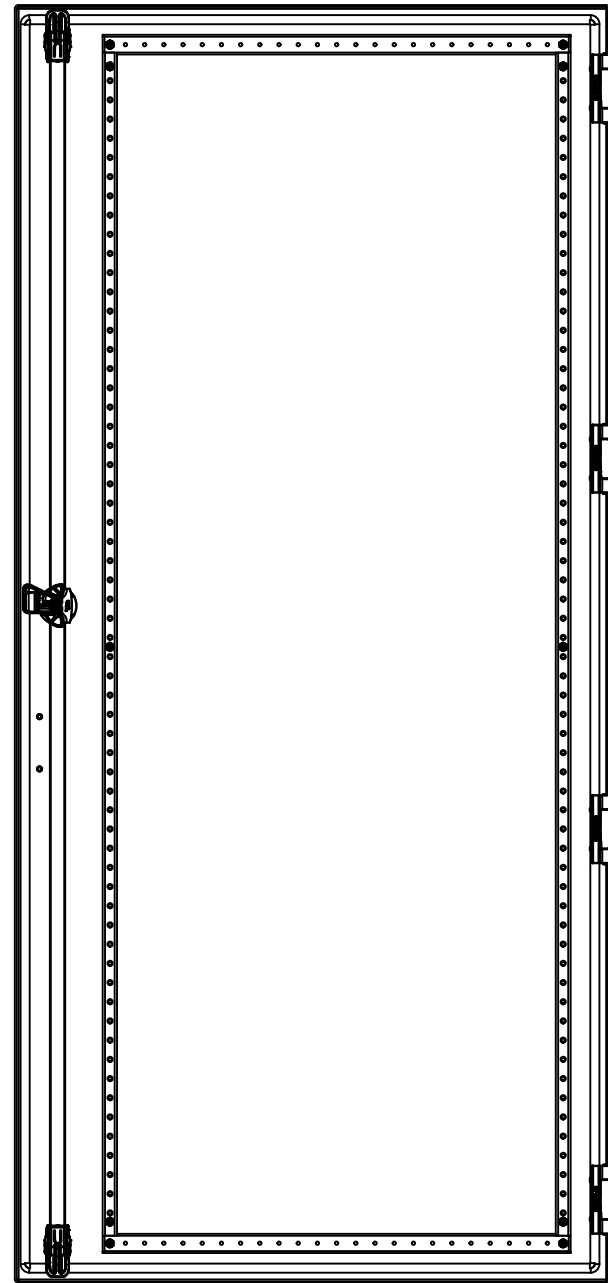

BACK



BOTTOM

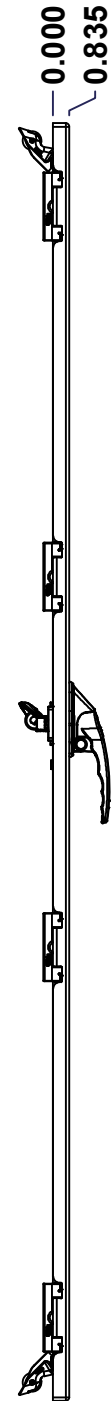

LEFT

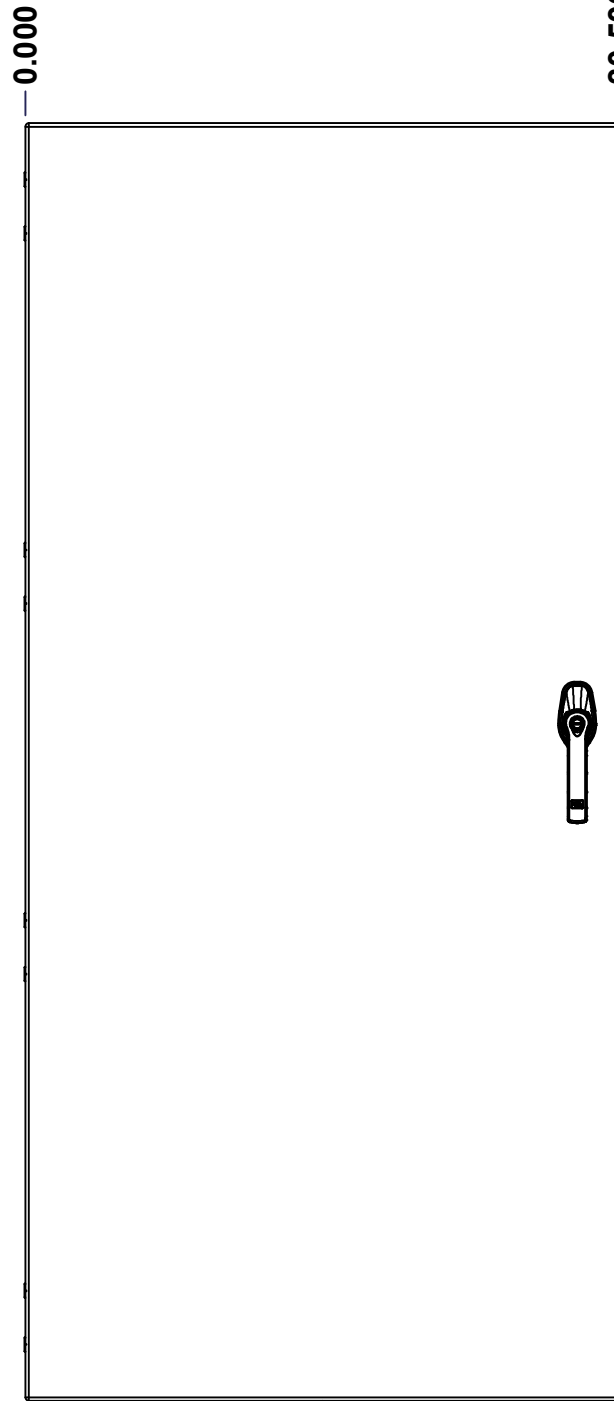

FRONT

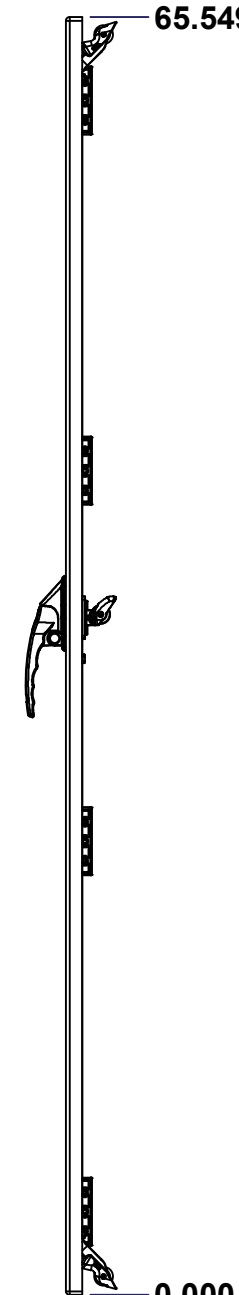

RIGHT

0.000
0.835

0.000

30.500

65.549

0.000

No.	Revisions	Date	By/Par

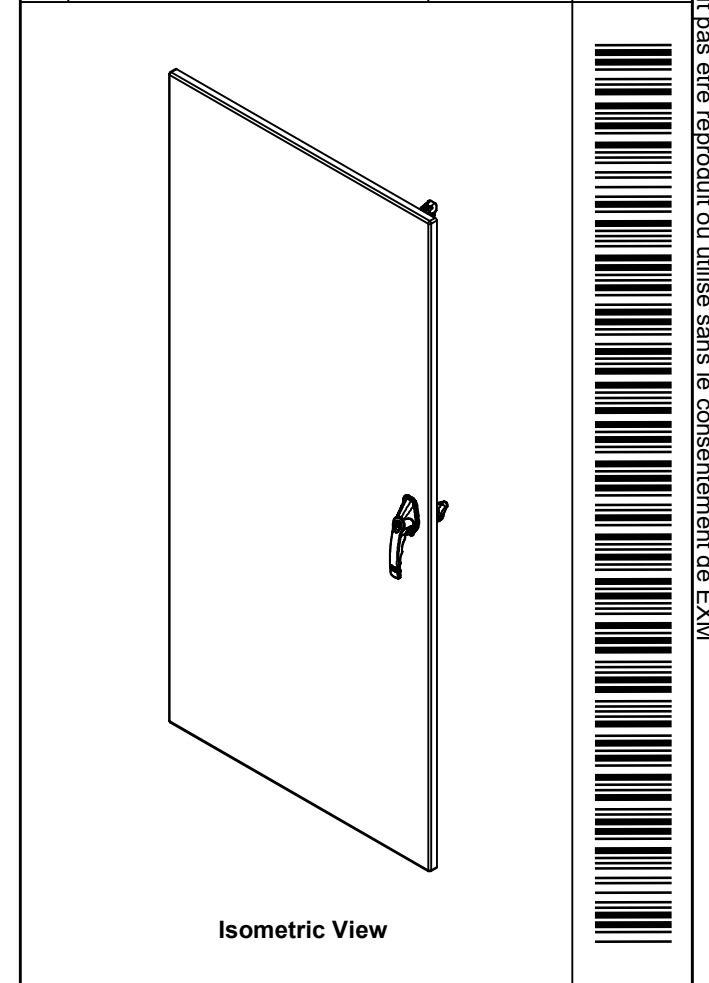

Isometric View

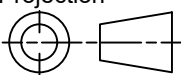
 Tél: (450) 979-4373 Fax: (450) 979-4626 www.exmweb.com		Flatness Aplatissement Max 3.0mm Projection 
Customer Client	Date	
Drawn By Dessiné Par	BoxCad: BoxCad	Date 5/3/2021
Material Matière	12 Ga Cold Rolled A1008 CS Type B (2.5mm)	
Color Couleur	Asa-61 Grey	Finish Fini Smooth
Description	Detail Rev.	
9500U2D 72" x 65.75" Lock Door		
Part Number Numéro Pièce	Rev.	13
9500U2D726618FD	0	17

SEE BILL OF MATERIAL ON LAST PAGE

This drawing is confidential and must not be reproduced or used without the consent of EXM

Ce dessin est confidentiel et ne doit pas être reproduit ou utilisé sans le consentement de EXM

STANDARD FEATURES ARE NOT LISTED IN THIS HOLE TABLE			
HOLE TABLE - FRONT VIEW (CUSTOM FEATURE ONLY)			
CUT-OUT	XDIM	YDIM	DESCRIPTION
1	2.375	2.028	STUD M6 x 18mm (Inside)
2	2.375	32.628	STUD M6 x 18mm (Inside)
3	2.375	63.521	STUD M6 x 18mm (Inside)
4	2.375	3.139	STUD M6 x 18mm (Inside)
5	2.375	62.409	STUD M6 x 18mm (Inside)
6	25.626	2.028	STUD M6 x 18mm (Inside)
7	25.626	32.628	STUD M6 x 18mm (Inside)
8	25.251	63.521	STUD M6 x 18mm (Inside)
9	25.626	3.139	STUD M6 x 18mm (Inside)
10	25.251	62.409	STUD M6 x 18mm (Inside)
11	28.313	6.118	LARGE GUIDE STUD (Inside)
12	28.313	59.431	LARGE GUIDE STUD (Inside)

13	28.312	34.743	HANDLE 885 ESL2A-APHD
14	29.247	26.363	STUDS M6 x 18mm (Inside)
15	29.247	29.041	STUDS M6 x 18mm (Inside)

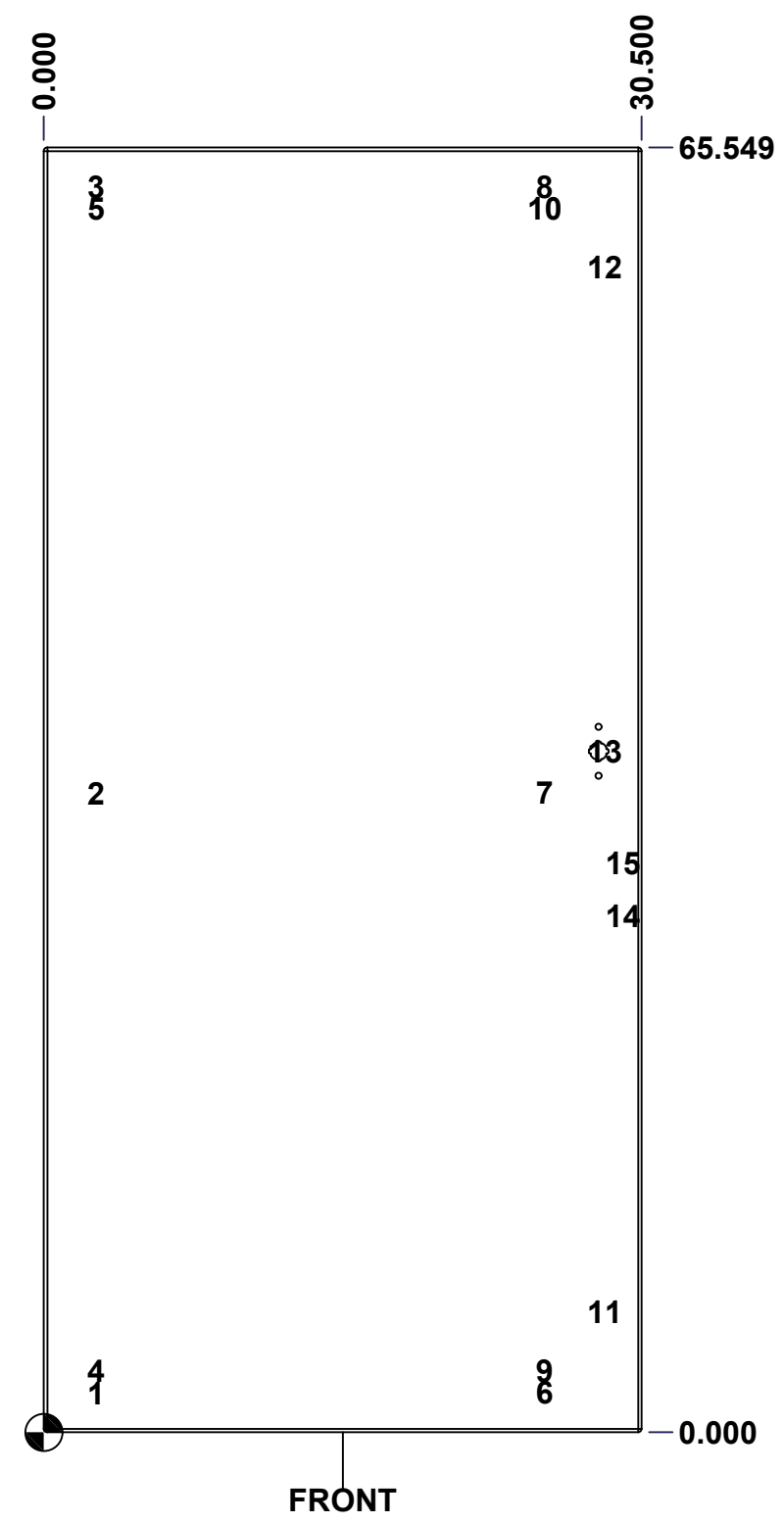

	Description		Status
	9500U2D 72" x 65.75" Lock Door		(NULL)
Part Number Numéro Pièce		Rev.	14
9500U2D726618FD		0	17

This drawing is confidential and must not be reproduced or used without the consent of EXM

Ce dessin est confidentiel et ne doit pas être reproduit ou utilisé sans le consentement de EXM

No.	Revisions	Date	By/Par

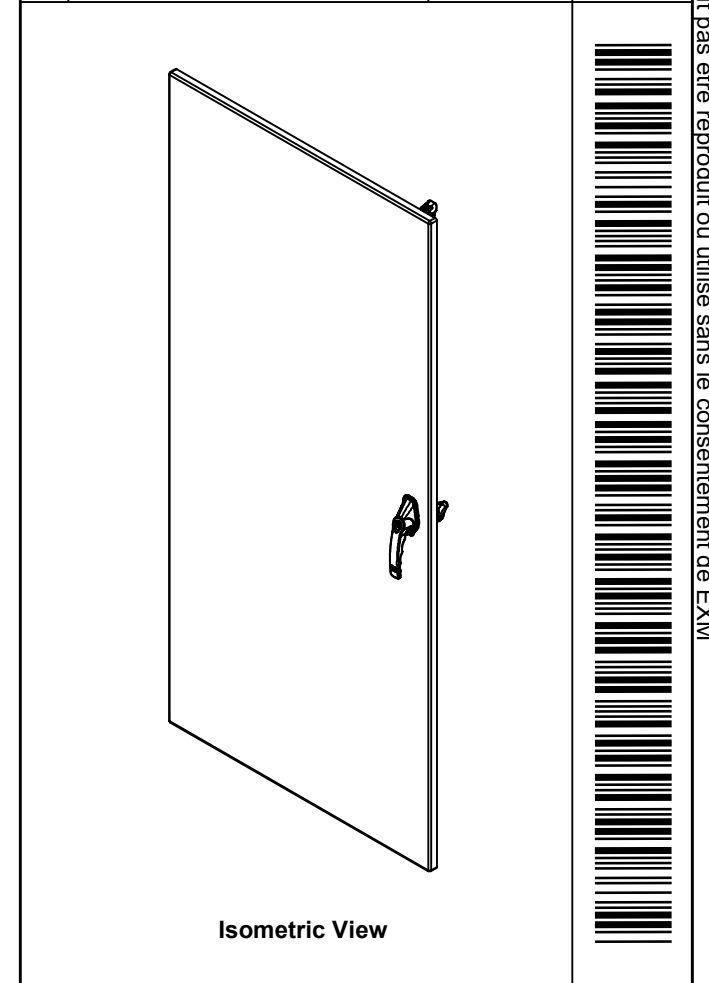

2	STK-Q-16050	1	Stud M6 x 18mm Steel
1	STK-Q-47562	0	9500 Lower Closing Bar 72" (cam)
1	STK-Q-47552	0	9500 Upper Closing Bar 72" (cam)
1	STK-A-50538	3	9500 Handle Cam Assembly (Right Side, Grip 36mm)
1	STK-Q-90051	3	5412 ES - Handle Cam Spacer
1	885ESL2A-APHD	1	885 ESL2A-APHD - Zinc Die Cast L-Handle Padlockable Assy - Slot Cylinder
1	STK-P-02400S	0	Powder Paint (Asa-61 Grey / Smooth)
1	9500U2D726618DS1	0	9500U2D 72" x 65.75" Door Stiffener
2	STK-Q-16410	0	Guide Stud - Largel (No Paint Cap Required)
10	STK-Q-16055	1	M6 x 18mm Stud (No Paint Cap Required)
1	9500U2D726618FDG	0	9500U2D 72" x 65.75" Flange Door Gasket
1	9500U2D726618FD-P	0	9500U2D 72" x 65.75" Lock Door Part
2	STK-A-90025	0	9500 - Cabinet Closing Bar End (Large)
4	STK-K-09860	7	Cabinet Hinge with Captive Pins
2	STK-Q-07220	1	M6 Nylon Insert Lock Nut

QTY	Part Number	Rev	Description
Parts List			

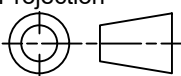
 Tél: (450) 979-4373 Fax: (450) 979-4626 www.exmweb.com		Flatness Aplatissement Max 3.0mm
Projection 		Date
Customer Client		Date 5/3/2021
Drawn By Dessiné Par BoxCad: BoxCad		Date
Material Matière 12 Ga Cold Rolled A1008 CS Type B (2.5mm)		
Color Couleur Asa-61 Grey	Finish Fini Smooth	
Description 9500U2D 72" x 65.75" Lock Door		Detail Rev.
Part Number Numéro Pièce 9500U2D726618FD		Rev. 15 0 17

This drawing is confidential and must not be reproduced or used without the consent of EXM

Ce dessin est confidentiel et ne doit pas être reproduit ou utilisé sans le consentement de EXM

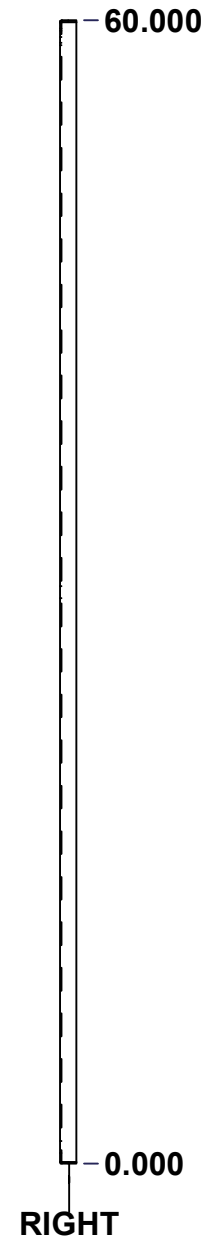
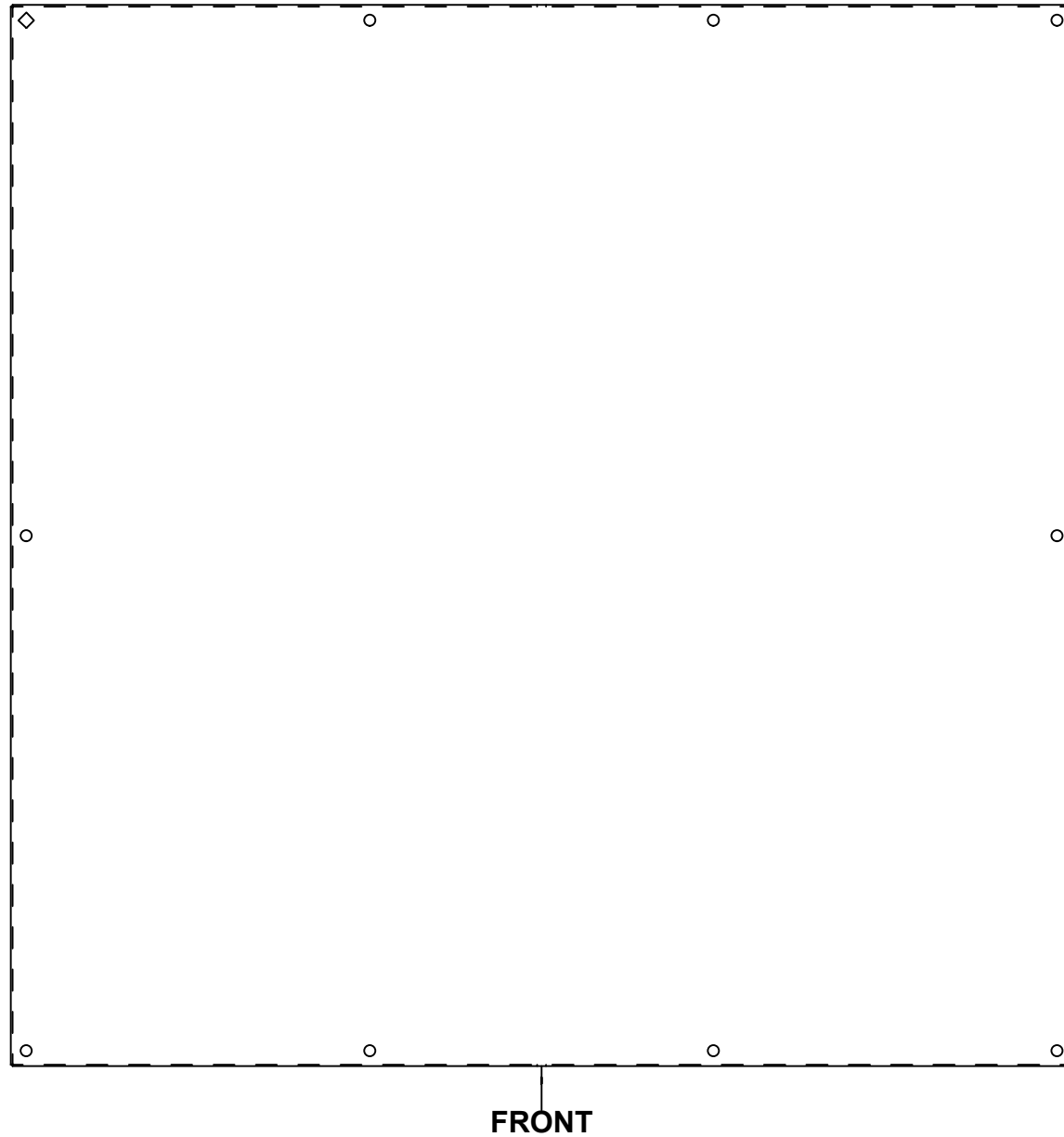
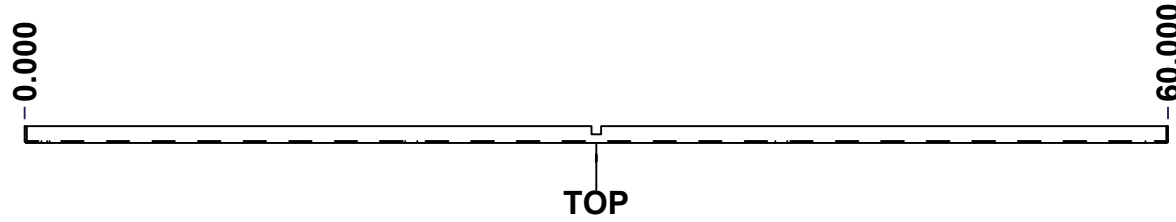

No.	Revisions	Date	By/Par

Isometric View

Tél: (450) 979-4373 Fax: (450) 979-4626 www.exmweb.com		Flatness Aplatissement	
		Max 3.0mm	
Customer Client		Date	
Drawn By Dessiné Par BoxCad: BoxCad		Date 5/3/2021	
Material Matière 12 Ga Cold Rolled A1008 CS Type B (2.5mm)			
Color Couleur White RAL9003		Finish Fini Smooth	
Description 9500U2D 72" x 65.75" Inner Panel			Detail Rev.
Part Number Numéro Pièce 9500U2D726618IP		Rev. 0	16 17

SEE BILL OF MATERIAL ON LAST PAGE

This drawing is confidential and must not be reproduced or used without the consent of EXM

Ce dessin est confidentiel et ne doit pas être reproduit ou utilisé sans le consentement de EXM

No.	Revisions	Date	By/Par

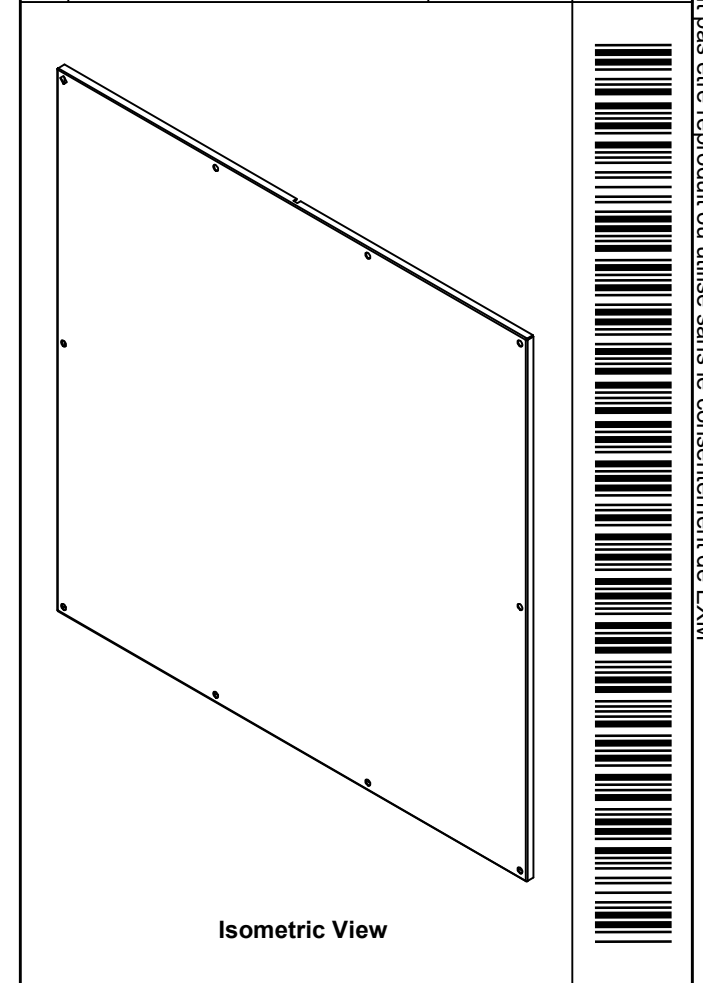

 Tél: (450) 979-4373 Fax: (450) 979-4626 www.exmweb.com		Flatness Aplatissement
		Max 3.0mm
Customer Client		Date
Drawn By Dessiné Par	BoxCad: BoxCad	Date 5/3/2021
Material Matière 12 Ga Cold Rolled A1008 CS Type B (2.5mm)		
Color Couleur	White RAL9003	Finish Fini Smooth
Description 9500U2D 72" x 65.75" Inner Panel		Detail Rev.
Part Number Numéro Pièce 9500U2D726618IP		Rev. 17 0 17

Qty	Part Number	Rev	Description
1	STK-P-02401S	0	Powder Paint (White / Smooth)
1	9500U2D726618IP-P	0	9500U2D 72" x 65.75" Inner Panel Part
Parts List			